



INVERTER

FR-D800

Instruction Manual (Function) (Standard model)

Compact & easy-to-use inverter

FR-D820-0.1K-008 to 15K-580

FR-D840-0.4K-012 to 15K-295

FR-D820S-0.1K-008 to 2.2K-100

FR-D810W-0.1K-008 to 0.75K-042

Chapter 1 Introduction	8
1.1 Product checking	9
1.2 Operation steps	11
1.3 Related manuals	13
Chapter 2 Basic Operation	14
2.1 Operation panel	14
2.1.1 Components of the operation panel	14
2.1.2 Basic operation of the operation panel	16
2.1.3 Digital characters and their corresponding printed equivalents	17
2.1.4 Changing the parameter setting value	17
2.2 Monitoring the inverter	19
2.2.1 Monitoring of output current and output voltage	19
2.2.2 First priority monitor screen.	19
2.2.3 Displaying the set frequency.	20
2.3 Easy setting of the inverter operation mode	21
2.4 Frequently-used parameters (simple mode parameters).	22
2.4.1 Simple mode parameter list	22
2.5 Basic operation procedure (PU operation)	24
2.5.1 Setting the frequency on the operation panel (example: operating at 30 Hz)	24
2.5.2 Setting the frequency with switches (multi-speed setting)	26
2.5.3 Setting the frequency using an analog signal (voltage input)	27
2.5.4 Setting the frequency using an analog signal (current input)	29
2.6 Basic operation procedure (External operation)	31
2.6.1 Setting the frequency on the operation panel	31
2.6.2 Setting the frequency and giving a start command with switches (multi-speed setting)	33
2.6.3 Setting the frequency using an analog signal (voltage input)	35
2.6.4 Changing the frequency (initial value: 60 Hz) at the maximum voltage input (initial value: 5 V)	37
2.6.5 Setting the frequency using an analog signal (current input)	38
2.6.6 Changing the frequency (initial value: 60 Hz) at the maximum current input (initial value: 20 mA)	40
2.7 Basic operation procedure (JOG operation)	41
2.7.1 Giving a start command by using external signals for JOG operation	41
2.7.2 Giving a start command from the operation panel for JOG operation.	43
2.8 I/O terminal function assignment	44

Chapter 3 Parameters 46

3.1	Parameter initial value groups	46
3.2	Parameter list (by parameter number)	47
3.3	Use of a function group number for the identification of parameters	63
3.4	Parameter list (by function group number)	64

Chapter 4 Control Method 70

4.1	Changing the control method and mode	72
4.2	Selecting the Advanced magnetic flux vector control	75
4.3	Selecting the PM sensorless vector control	77

Chapter 5 Speed control under PM sensorless vector control 84

5.1	Setting procedure of PM sensorless vector control (speed control)	85
5.2	Setting the torque limit level	87
5.3	Performing high-accuracy, fast-response control (gain adjustment)	90
5.4	Adjustment when the motor wiring length is long	93
5.5	Troubleshooting in the speed control	94

Chapter 6 (E) Environment Setting Parameters 95

6.1	Clock	96
6.2	Reset selection/disconnected PU detection/PU stop selection	97
6.3	PU display language selection	100
6.4	Buzzer control	101

6.5	PU contrast adjustment	102
6.6	Display-off setting	103
6.7	Automatic frequency setting / key lock operation selection	104
6.8	Frequency change increment amount setting	106
6.9	RUN key rotation direction selection	107
6.10	Multiple rating setting	108
6.11	Parameter write selection	109
6.12	Password	111
6.13	Free parameter	114
6.14	Setting multiple parameters by batch	115
6.15	Extended parameter display and user group function	117
6.16	PWM carrier frequency and Soft-PWM control	120
6.17	Inverter parts life display	122
6.18	Maintenance timer alarm	126
6.19	Current average value monitor signal	127
Chapter 7 (F) Settings for Acceleration/Deceleration		130
7.1	Setting the acceleration and deceleration time	130
7.2	Acceleration/deceleration pattern	133
7.3	Remote setting function	135
7.4	Starting frequency and start-time hold function	139
7.5	Minimum motor speed frequency at the motor start up	141

Chapter 8 (D) Operation Command and Frequency Command 142

8.1	Operation mode selection	142
8.2	Startup of the inverter in Network operation mode at power-ON	152
8.3	Start command source and frequency command source during communication operation.	153
8.4	Reverse rotation prevention selection	158
8.5	Frequency setting using pulse train input.	159
8.6	JOG operation	161
8.7	Operation by multi-speed setting	163

Chapter 9 (H) Protective Function Parameters 165

9.1	Motor overheat protection (electronic thermal O/L relay)	166
9.2	Cooling fan operation selection	174
9.3	Earth (ground) fault detection at start.	175
9.4	Inverter output fault detection enable/disable selection	176
9.5	Initiating a protective function.	177
9.6	I/O phase loss protection selection	178
9.7	Retry function	179
9.8	Emergency drive	182
9.9	Checking faulty area in the internal storage device	190
9.10	Limiting the output frequency (maximum/minimum frequency)	191
9.11	Avoiding machine resonance points (frequency jump).	193
9.12	Stall prevention operation.	195

9.13	Load characteristics fault detection	200
9.14	Motor overspeeding detection	205
Chapter 10 (M) Item and Output Signal for Monitoring		206
10.1	Speed indication and its setting change to rotations per minute	206
10.2	Monitor item selection on operation panel or via communication	208
10.3	Monitor display selection for terminal AM	216
10.4	Adjustment of terminal AM.	218
10.5	Energy saving monitoring	219
10.6	Output terminal function selection	226
10.7	Output frequency detection	234
10.8	Output current detection function.	237
10.9	Remote output function	239
10.10	Pulse train output of output power.	241
10.11	Detection of control circuit temperature.	242
Chapter 11 (T) Multi-Function Input Terminal Parameters		243
11.1	Analog input selection	243
11.2	Response level of analog input and noise elimination.	247
11.3	Frequency setting voltage (current) bias and gain.	248
11.4	Input terminal function selection	252
11.5	Inverter output shutoff	255
11.6	Selecting the condition to activate the Second function selection (RT) signal.	257
11.7	Start signal operation selection	258

Chapter 12 (C) Motor Constant Parameters 261

12.1	Applied motor	261
12.2	Offline auto tuning	266
12.3	Offline auto tuning for a PM motor	274

Chapter 13 (A) Application Parameters 281

13.1	Traverse function	281
13.2	PID control	283
13.3	Calibration of PID display	297
13.4	Dancer control	300
13.5	Automatic restart after instantaneous power failure / flying start with an induction motor . . .	307
13.6	Automatic restart after instantaneous power failure / flying start with a PM motor.	312
13.7	Offline auto tuning for a frequency search	314
13.8	Power failure time deceleration-to-stop function	318
13.9	Trace function.	320

Chapter 14 (G) Control Parameters 327

14.1	Manual torque boost.	327
14.2	Base frequency voltage	329
14.3	Load pattern selection	331
14.4	Energy saving control.	333
14.5	SF-PR slip amount adjustment mode.	334
14.6	DC injection brake	335
14.7	Stop selection.	338

14.8	Regenerative brake selection	340
14.9	Regeneration avoidance function	345
14.10	Increased magnetic excitation deceleration	348
14.11	Slip compensation	350
14.12	Speed smoothing control	351
14.13	Vibration suppression control	352

Chapter 15 Checking and Clearing of Settings **353**

15.1	Parameter clear / All parameter clear	353
15.2	List of parameters changed from the initial values	354
15.3	Fault history clear	355
15.4	Changing the parameter initial value group	356

Chapter 16 Appendix **357**

16.1	For customers replacing the conventional model with this inverter	357
16.1.1	Replacement of the FR-D700 series	357
16.2	Specification comparison between PM sensorless vector control and induction motor control	359
16.3	Parameters (functions) and instruction codes under different control methods	360
	Warranty	369
	Revisions	370

1 Introduction

The contents described in this chapter must be read before using this product.

Always read the instructions before use.

◆ Abbreviations

Item	Description
Operation panel	Inverter's operation panel, LCD operation panel (FR-LU08), and enclosure surface operation panel (FR-PA07)
Parameter unit	Parameter unit (FR-PU07)
PU	Operation panel and parameter unit
Inverter	Mitsubishi Electric FR-D800 series inverter
D800	Standard model (RS-485 communication)
Pr.	Parameter number (Number assigned to function)
PU operation	Operation using the PU (operation panel / parameter unit)
External operation	Operation using the control circuit signals
Combined operation	Combined operation using the PU (operation panel / parameter unit) and External operation
Mitsubishi Electric standard efficiency motor	SF-JR
Mitsubishi Electric constant-torque motor	SF-HRCA
Mitsubishi Electric high-performance energy-saving motor	SF-PR
Mitsubishi Electric PM motor	EM-A

◆ Trademarks

- MODBUS is a registered trademark of SCHNEIDER ELECTRIC USA, INC.
- Other company and product names herein are the trademarks and registered trademarks of their respective owners.

◆ Notes on descriptions in this Instruction Manual

- Connection diagrams in this Instruction Manual appear with the control logic of the input terminals as sink logic, unless otherwise specified. (Refer to the Instruction Manual (Connection) for the switching of the control logic of the inverter.)

1.1 Product checking

◆ Inverter model

FR-D8 2 0 - 0.1K-008

A B C D E

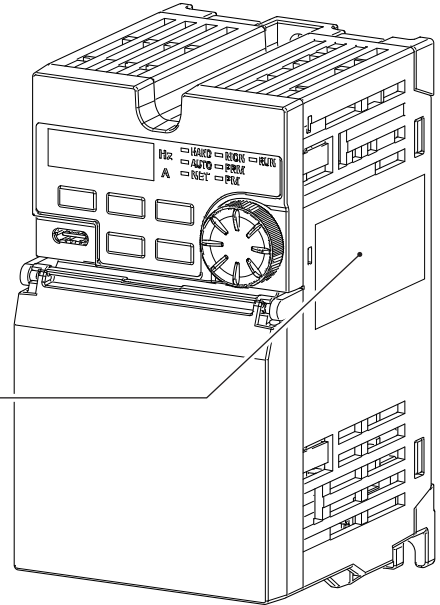
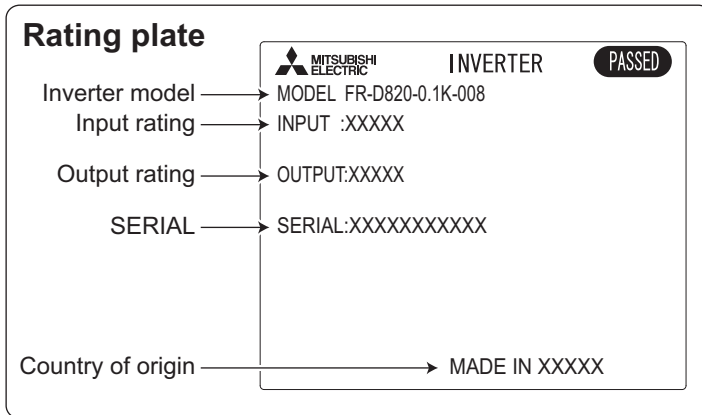

- A: The voltage class is shown.

Symbol	Voltage class
1	100 V class
2	200 V class
4	400 V class

- B: The protective structure is shown.

Symbol	Protective structure
0	Open type (IP20)

- C: The number of phases of the power source is shown.

Symbol	Description
None	Three-phase input
S	Single-phase input
W	Single-phase input (double voltage output)

- D: The applicable motor capacity and the inverter rated current are shown.

Symbol	Description
Example) 200 V class 0.1K-008 to 15K-580	Applicable motor capacity (ND) (kW) - Inverter rated current (ND) (A)

- E: Availability of circuit board coating is shown.

Symbol	Circuit board coating ^{*1}
None	Without coating
-60	With coating

*1 Conforming to IEC 60721-3-3:1994 3C2/3S2

◆ How to read the SERIAL number

Rating plate example

Symbol Year Month Control number

SERIAL

The SERIAL consists of two symbols, three characters indicating the production year and month, and six characters indicating the control number.

The last two digits of the production year are indicated as the Year, and the Month is indicated by 1 to 9, X (October), Y (November), or Z (December).

◆ Specification differences by the country of origin

The rated frequency (initial setting) and the control logic (initial status) of the input signal differ depending on the country of origin.

For the country of origin, refer to the rating plate ([page 9](#)).

Country of origin indication (on the rating plate)	Rated frequency (initial setting)	Control logic	
		Input signal (initial status)	Safety stop signal
MADE IN JAPAN	60 Hz	Sink logic	Source logic (fixed)
MADE IN CHINA	50 Hz	Source logic	

1.2 Operation steps

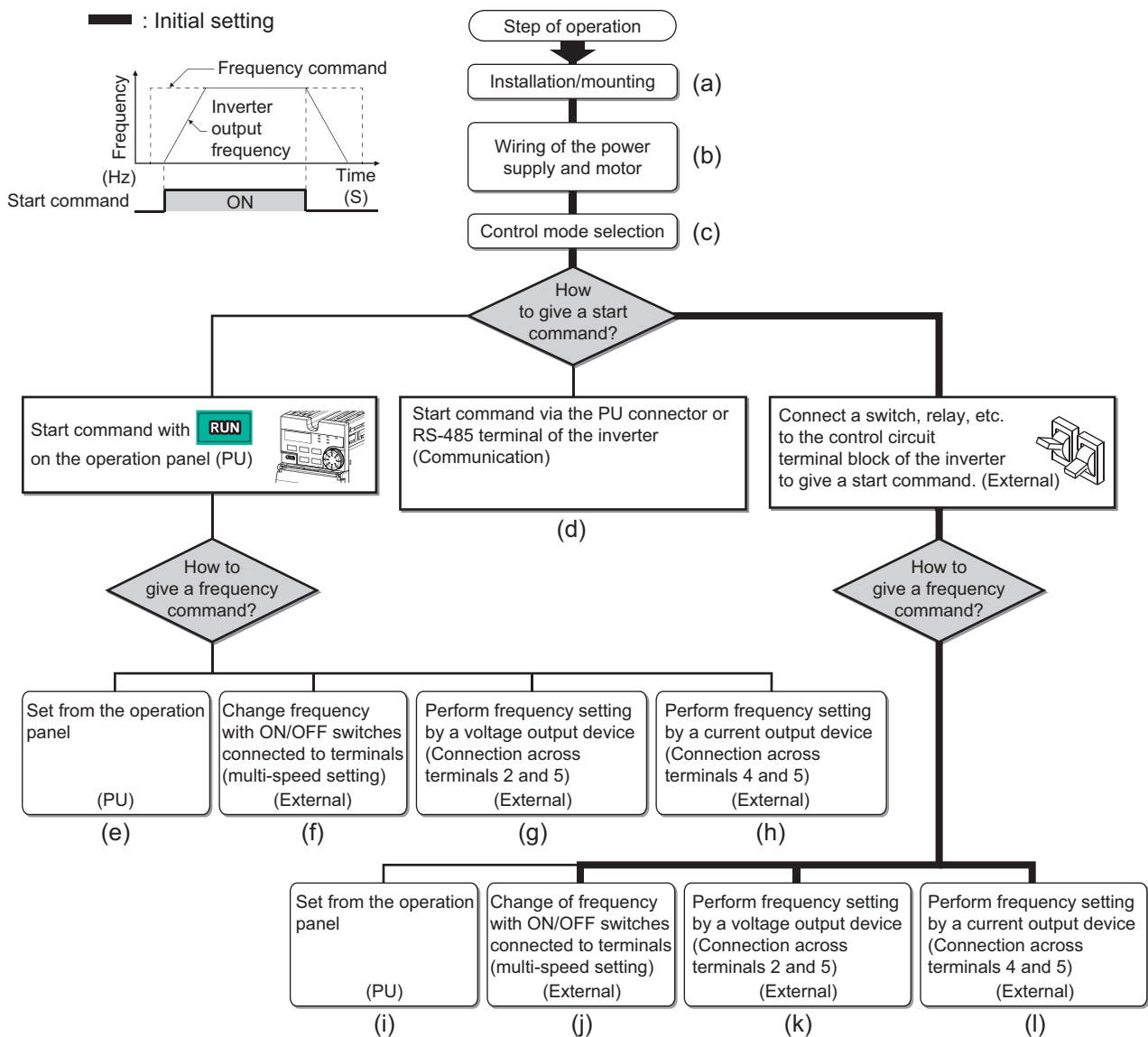

Symbol	Overview	Refer to page
(a)	Install the inverter.	Instruction Manual (Connection)
(b)	Perform wiring for the power supply and the motor.	Instruction Manual (Connection)
(c)	Select the control method (V/F control, Advanced magnetic flux vector control, and PM sensorless vector control).	70
(d)	Give the start command via communication.	Instruction Manual (Communication)
(e)	Give both the start and frequency commands from the PU. (PU operation mode)	24
(f)	Give the start command from the PU and the frequency command via terminals RH, RM, and RL. (External/PU combined operation mode 2)	26
(g)	Give the start command from the PU and the frequency command by voltage input via terminal 2. (External/PU combined operation mode 2)	27
(h)	Give the start command from the PU and the frequency command by current input via terminal 4. (External/PU combined operation mode 2)	29
(i)	Give the start command via terminal STF or STR and the frequency command from the PU. (External/PU combined operation mode 1)	31

Symbol	Overview	Refer to page
(j)	Give the start command via terminal STF or STR and the frequency command via terminals RH, RM, and RL. (External operation mode)	33
(k)	Give the start command via terminal STF or STR and the frequency command by voltage input via terminal 2. (External operation mode)	35
(l)	Give the start command via terminal STF or STR and the frequency command by current input via terminal 4. (External operation mode)	38

1.3 Related manuals

When using this inverter for the first time, prepare the following manuals as required and use the inverter safely. The latest version of e-Manuals and the latest PDF manuals can be downloaded from the Mitsubishi Electric FA Website.

Point 

- e-Manual refers to the Mitsubishi FA electronic book manuals that can be browsed using a dedicated tool.
- e-Manual has the following features:
 - Required information can be cross-searched in multiple manuals.
 - Pages that users often browse can be bookmarked.

The following shows the manuals related to the FR-D800 inverter.

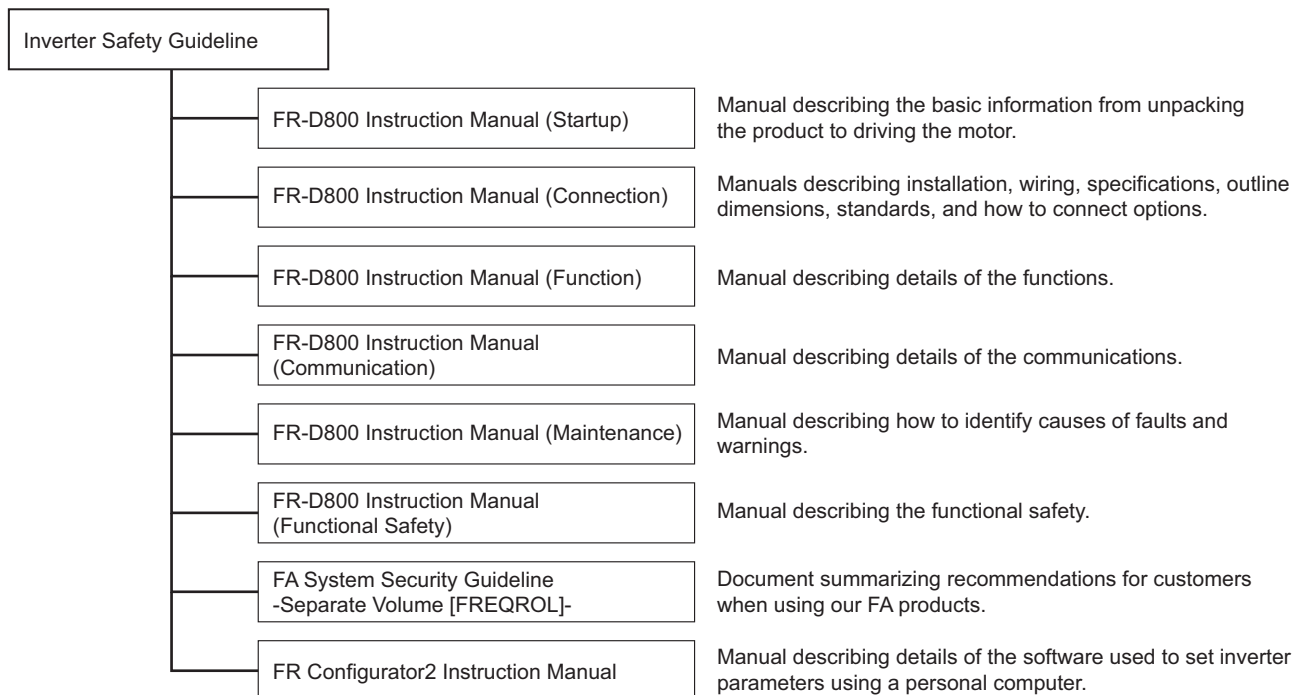

Name	Manual number
FR-D800 Inverter Safety Guideline	IB-0601019
FR-D800 Instruction Manual (Startup)	IB-0601026ENG
FR-D800 Instruction Manual (Connection)	IB-0601029ENG
FR-D800 Instruction Manual (Communication)	IB-0601039ENG
FR-D800 Instruction Manual (Maintenance)	IB-0601044ENG
FR-D800 Instruction Manual (Functional Safety)	BCN-A23498-007(E)
FA System Security Guideline -Separate Volume [FREQROL]-	BCN-C22005-1054
FR Configurator2 Instruction Manual	IB-0600516ENG

2 Basic Operation

This chapter explains the basic operation of this product.
Always read the instructions before use.





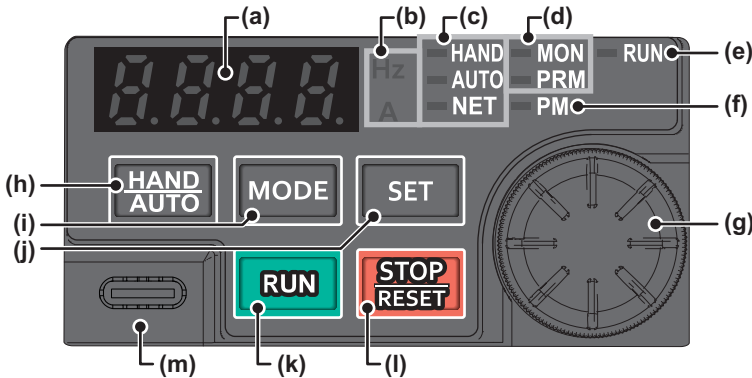

2.1 Operation panel

2.1.1 Components of the operation panel

The operation panel cannot be removed from the inverter.

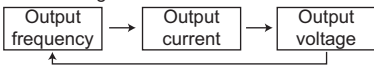

No.	Appearance	Name	Description
(a)		Monitor (4-digit LED)	Shows a numeric value (readout) of a monitor item such as the frequency or a parameter number. (The monitor item can be changed according to the settings of Pr.52 , Pr.774 to Pr.776 .)
(b)		Unit indication	Hz: ON when the actual frequency is monitored. (Blinks when the set frequency is monitored.) A: ON when the current is monitored. (Both "Hz" and "A" are OFF to indicate a value other than the frequency or the current.)
(c)		Inverter operation mode LED indicator	HAND: ON when the inverter is in the PU operation mode. AUTO: ON when the inverter is in the External operation mode. (ON when the inverter in the initial setting is powered ON.) NET: ON when the inverter is in the Network operation mode. Both HAND and AUTO are ON when the inverter is in the External/PU combined operation mode 1 or 2.
(d)		Operation panel mode LED indicator	MON: ON only when the first, second, or third monitor is displayed. PRM: ON when the operation panel is in the parameter setting mode. The indicator blinks when the inverter is in the easy setting mode.
(e)		Operating status indicator	ON or blinks during inverter running. ON: During forward rotation operation. Blinks slowly (1.4-second cycle): During reverse rotation operation. Blinks quickly (0.2-second cycle): Operation is disabled although the start command is given.*1
(f)		Controlled motor type LED indicator	ON when the PM sensorless vector control is selected. The indicator blinks during test operation. The indicator is OFF when the inverter controls the induction motor.
(g)		Setting dial	The setting dial of the Mitsubishi Electric inverters. Turn the setting dial to change the setting of frequency or parameter, etc. Press the setting dial to perform the following operations: • To display a set frequency on the LED display in the monitor mode. (The monitor item shown on the display can be changed by using Pr.992 .) • To display the present setting during calibration.
(h)		HAND/AUTO key	Switches between the PU operation mode, the PUJOG operation mode, and the External operation mode. The easy setting of the inverter operation mode is enabled by pressing this key simultaneously with the MODE key. Also cancels the PU stop warning.

No.	Appearance	Name	Description
(i)		MODE key	Switches the operation panel to a different mode. The easy setting of the inverter operation mode is enabled by pressing this key simultaneously with the HAND/AUTO key. Every key on the operation panel becomes inoperable by holding this key for two seconds. The key lock function is disabled when Pr.161 = "0 (initial setting)". (Refer to page 104 .)
(j)		SET key	Confirms each selection. When this key is pressed during inverter operation, the monitor item changes. (The monitor item on each screen can be changed according to the settings of Pr.52 , Pr.774 to Pr.776 .) Initial setting in the monitor mode 
(k)		RUN key	Start command The direction of motor rotation depends on the Pr.40 setting. When Pr.40 = "0 (initial value)", the motor starts forward rotation.
(l)		STOP/RESET key	Stops the operation commands. Used to reset the inverter when the protective function is activated.
(m)		USB connector	FR Configurator2 is available by USB connection. (USB Type-C)

*1 Situations such as when the MRS/X10 signal is input, during the automatic restart after instantaneous power failure, after auto tuning is complete, when "SE" (incorrect parameter setting) alarm occurs.

2.1.2 Basic operation of the operation panel

◆ Basic operation

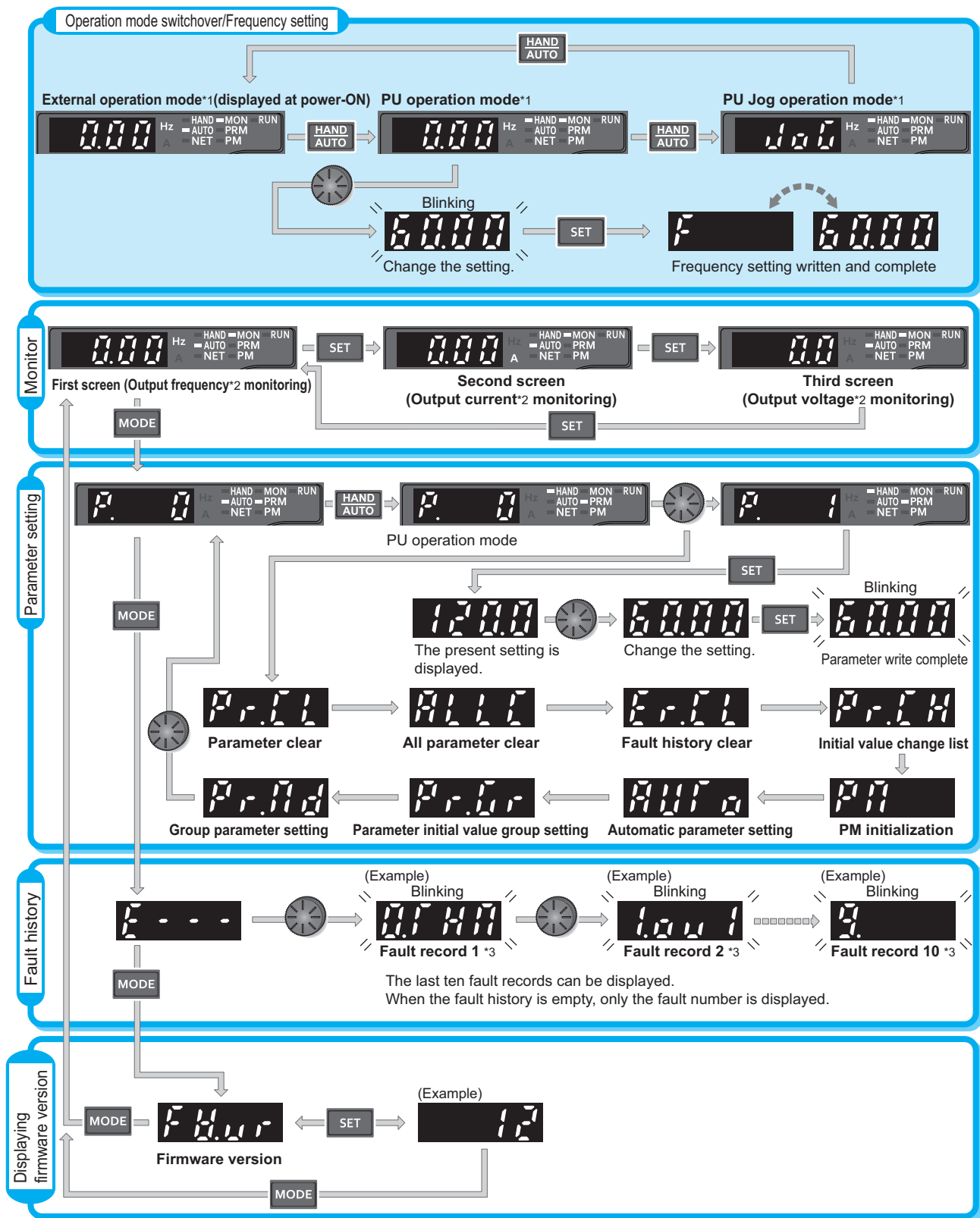

*1 For details on operation modes, refer to [page 142](#).

*2 The monitor item can be changed. (Refer to [page 208](#).)

*3 For details on the fault history, refer to the Instruction Manual (Maintenance).

◆ Parameter setting mode

In the parameter setting mode, inverter functions (parameters) are set.

The following table explains the indications in the parameter setting mode.

Operation panel indication	Function name	Description	Refer to page
<i>P.</i>	Parameter setting mode	Under this mode, the set value of the displayed parameter number is read or changed. If the setting is changed using a different interface while the value is displayed, the new setting may not be applied. In such a case, read the set value again.	17
<i>Pr.CL</i>	Parameter clear	Clears and resets parameter settings to the initial values. Calibration parameters and offline auto tuning parameters are not cleared. For details on the uncleared parameters, refer to page 360 .	353
<i>ALLC</i>	All parameter clear	Clears and resets parameter settings to the initial values. Calibration parameters and the offline auto tuning parameters are also cleared. For details on the uncleared parameters, refer to page 360 .	353
<i>Er.CL</i>	Fault history clear	Deletes the fault history.	355
<i>Pr.CH</i>	Initial value change list	Identifies the parameters that have been changed from their initial settings.	354
<i>Pn</i>	PM parameter initialization	Changes the parameter settings required to drive a PM motor to the settings for V/F control as a batch.	77
<i>Auto</i>	Automatic parameter setting	Changes parameter settings as a batch. The target parameters include communication parameters for the Mitsubishi Electric human machine interface (GOT) connection and the parameters for the rated frequency settings of 50/60 Hz.	115
<i>Pr.Gr</i>	Parameter initial value group setting	Changes the parameter initial value group.	356
<i>Pr.Nd</i>	Group parameter setting	Displays parameter numbers by function groups.	63

2.1.3 Digital characters and their corresponding printed equivalents

Digital characters displayed on the operation panel display are as follows.

0	1	2	3	4	5	6	7	8	9	A	B	C
<i>0</i>	<i>1</i>	<i>2</i>	<i>3</i>	<i>4</i>	<i>5</i>	<i>6</i>	<i>7</i>	<i>8</i>	<i>9</i>	<i>A</i>	<i>b</i>	<i>C</i>
<i>D</i>	<i>E</i>	<i>F</i>	<i>G</i>	<i>H</i>	<i>I</i>	<i>J</i>	<i>K</i>	<i>L</i>	<i>M</i>	<i>N</i>	<i>O</i>	<i>P</i>
<i>d</i>	<i>E</i>	<i>F</i>	<i>G</i>	<i>H</i>	<i>,</i>	<i>J</i>	<i>K</i>	<i>L</i>	<i>n</i>	<i>n</i>	<i>o</i>	<i>P</i>
<i>Q</i>	<i>R</i>	<i>S</i>	<i>T</i>	<i>U</i>	<i>V</i>	<i>W</i>	<i>X</i>	<i>Y</i>	<i>Z</i>	<i>-</i>	<i>-</i>	
<i>q</i>	<i>r</i>	<i>s</i>	<i>t</i>	<i>u</i>	<i>v</i>	<i>w</i>	<i>x</i>	<i>y</i>	<i>z</i>	<i>-</i>	<i>-</i>	

2.1.4 Changing the parameter setting value

- Select the parameter number in the parameter setting mode and press the SET key to change the parameter setting value.
- After changing the parameter setting value, press the SET key to write the setting value to the inverter.
- When the parameter number is 4-digit, "Pr." and the parameter number are displayed alternately.
- When the parameter number is 5-digit, the upper 1 digit and the lower 4 digits of the parameter number are displayed alternately.

◆ Parameter setting screen

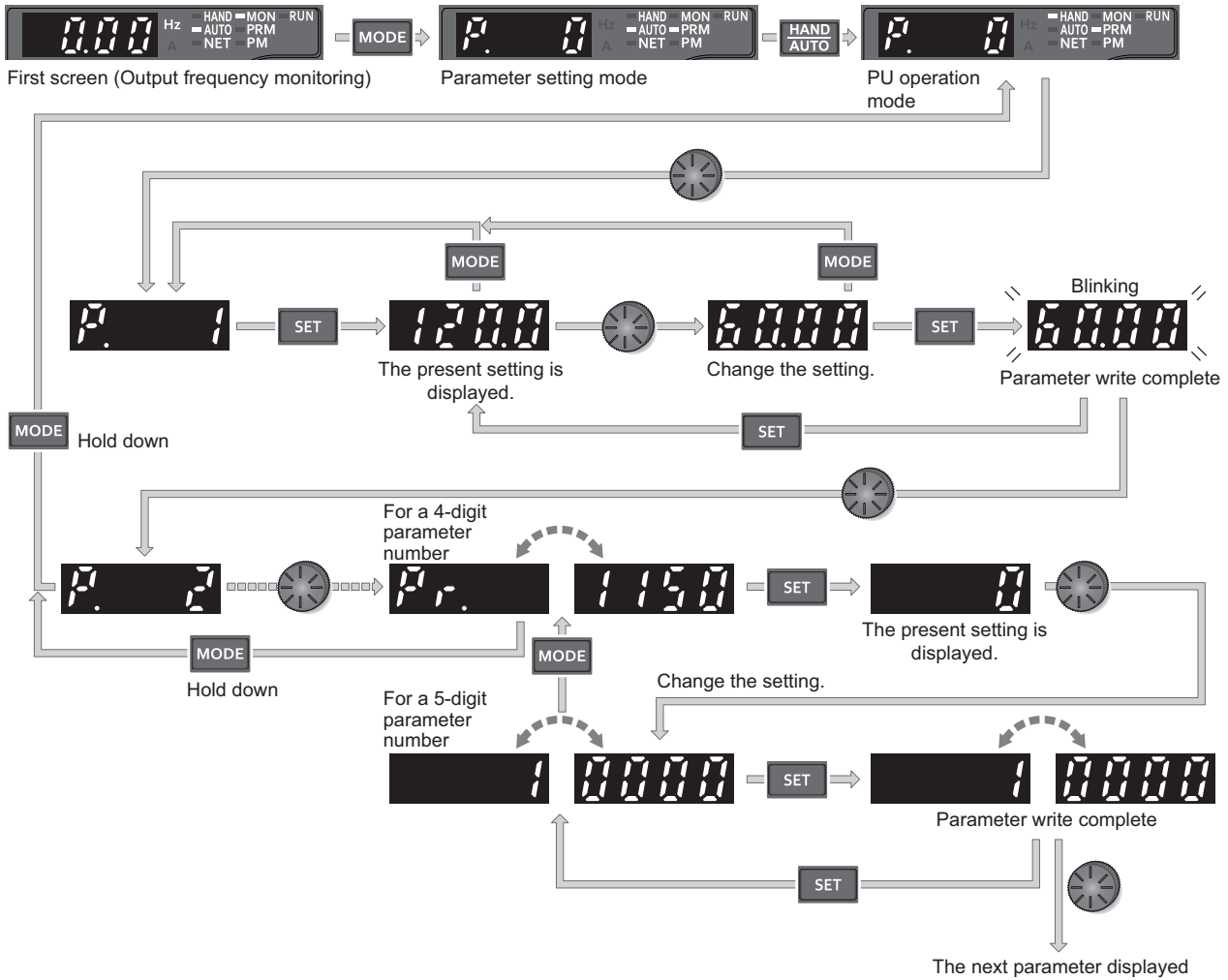

NOTE

- If a parameter write condition is not satisfied, a parameter write error appears. (For details of the errors, refer to the Instruction Manual (Maintenance).)

Error indication	Description
Er 1	Parameter write error
Er 2	Write error during operation
Er 3	Calibration error
Er 4	Mode designation error

- When **Pr.77 Parameter write selection** = "0 (initial setting)", the parameter setting change is only available while the inverter is stopped and under the PU operation mode. To enable the parameter setting change while the inverter is running or under the operation mode other than PU operation mode, change the **Pr.77** setting. (Refer to [page 109](#).)

2.2 Monitoring the inverter

2.2.1 Monitoring of output current and output voltage

Point

- Press the SET key on the operation panel in the monitor mode to switch the monitor item between output frequency, output current, and output voltage.

Operating procedure

1. Press the MODE key during inverter operation to monitor the output frequency. The [Hz] LED turns ON.
2. Press the SET key to monitor the output current. This operation is valid during running or stopping under any operation mode. The [A] LED turns ON.
3. Press the SET key to monitor the output voltage. This operation is valid during running or stopping under any operation mode. Unit LEDs are both OFF.

NOTE

- Other monitor item, such as output power or set frequency, is also available. Use **Pr.52 Operation panel main monitor selection** or **Pr.774 Operation panel monitor selection 1 to Pr.776 Operation panel monitor selection 3** to change the setting. (Refer to [page 208](#).)

2.2.2 First priority monitor screen

The first priority monitor screen, which is displayed first when the operation panel switches to the monitor mode, is selectable. To set it, press the SET key for a while when the desired monitor item is displayed on a monitor screen.

The following show the procedure to set the monitor screen displaying the output current as the first priority monitor screen.

Operating procedure

1. Change the mode of the operation panel to the monitor mode, and switch the monitor screen to the one on which the output current can be monitored.
2. Press the SET key for a while (1 second). The output current monitor screen is set as the first priority monitor screen.
3. When the operation panel is in the monitor mode next time, the output current monitored value is displayed first.

NOTE

- Use **Pr.52 Operation panel main monitor selection** or **Pr.774 Operation panel monitor selection 1 to Pr.776 Operation panel monitor selection 3** to change the monitor item. (Refer to [page 208](#).)

2.2.3 Displaying the set frequency

To display the present set frequency, change the mode of the operation panel to the monitor mode and press the setting dial



() while the inverter runs in the PU operation mode or in the External/PU combined operation mode 1 (**Pr.79 Operation mode selection** = "3").

NOTE

- Use **Pr.992 Operation panel setting dial push monitor selection** to change the item to be displayed. (Refer to [page 208.](#))

2.3 Easy setting of the inverter operation mode

The operation mode suitable for start and speed command combinations can be set easily using **Pr.79 Operation mode selection**.

The following shows the procedure to operate with the external start command (STF/STR) and the frequency command by using the operation panel.

Operating procedure

1. Press the HAND/AUTO key and MODE key for 0.5 second at the same time.



2. Turn the setting dial until "79-3" (External/PU combined operation mode 1) appears.



3. Press the SET key to confirm the setting. External/PU combined operation mode 1 (**Pr.79 = "3"**) is set. For other settings, refer to the following table.

Operation panel indication	Operation method		Operation mode
	Start command	Frequency command	
Blinking	RUN key	Setting dial	PU operation mode
Blinking	External (STF/STR signal)	Analog voltage input	External operation mode
Blinking	External (STF/STR signal)	Setting dial	External/PU combined operation mode 1
Blinking	RUN key	Analog voltage input	External/PU combined operation mode 2

NOTE

- When the user group function is used (**Pr.160 = "1"**) or the password function is enabled (with **Pr.296** and **Pr.297**), the easy setting is disabled (**Pr.79** is not displayed).
- "ER2" appears if a setting change is attempted during inverter operation. Turn OFF the start command (the RUN key or STF/STR signal).
- If the MODE key is pressed before pressing the SET key, the easy setting mode is terminated and the operation panel returns to the monitor mode. If the easy setting is terminated while **Pr.79 = "0"** (initial value), check the inverter operation mode because the inverter may switch its operation mode between the PU operation mode and the External operation mode.
- Reset by pressing the STOP/RESET key is enabled.
- The following is the frequency commands listed in descending order of priority when "3" is set in **Pr.79**: Multi-speed setting function (RL/RM/RH/REX signal) > PID control (X14 signal) > terminal 4 analog input (AU signal) > set frequency (digital input from the PU).

2.4 Frequently-used parameters (simple mode parameters)

Parameters that are frequently used for the FR-D800 series are grouped as simple mode parameters.

When **Pr.160 User group read selection** = "9999", only the simple mode parameters are displayed on the operation panel. This section explains the simple mode parameters.

2.4.1 Simple mode parameter list

For simple variable-speed operation of the inverter, the initial values of the parameters may be used as they are. Set the necessary parameters to meet the load and operational specifications. Parameter's setting, change and check can be made on the operation panel.



- **Pr.160 User group read selection** can narrow down the displayed parameters to only the simple mode parameters. (In the initial setting, all parameters are displayed.) Set **Pr.160 User group read selection** as required. (To change the parameter setting, refer to [page 17.](#))

Pr.160 setting	Description
9999	Only simple mode parameters are displayed.
0 (initial value)	All parameters (simple mode parameters and extended parameters) are displayed.
1	Only parameters registered in user groups are displayed.

◆ Simple mode parameters

Pr.	Pr. group	Name	Increment	Initial value ^{*4}		Range	Application	Refer to page
				Gr.1	Gr.2			
0	G000	Torque boost	0.1%	6% ^{*1}		0% to 30%	Set this parameter to obtain a higher starting torque under V/F control. Also set this when a loaded motor cannot be driven, the warning "OL" occurs, and the inverter output is shut off with the fault indication "E.OC1".	327
				4% ^{*1}				
				3% ^{*1}				
				2% ^{*1}				
1	H400	Maximum frequency	0.01 Hz	120 Hz		0 to 120 Hz	Set the upper limit for the output frequency.	191
2	H401	Minimum frequency	0.01 Hz	0 Hz		0 to 120 Hz	Set the lower limit for the output frequency.	
3	G001	Base frequency	0.01 Hz	60 Hz	50 Hz	0 to 590 Hz	Set this parameter when the rated motor frequency is 50 Hz. Check the rating plate of the motor.	329
4	D301	Multi-speed setting (high speed)	0.01 Hz	60 Hz	50 Hz	0 to 590 Hz	Pre-set the speeds that will be switched among by terminals.	26, 33, 163
5	D302	Multi-speed setting (middle speed)	0.01 Hz	30 Hz		0 to 590 Hz		
6	D303	Multi-speed setting (low speed)	0.01 Hz	10 Hz		0 to 590 Hz		
7	F010	Acceleration time	0.1 s	5 s ^{*2}		0 to 3600 s	Set the acceleration time.	130
				10 s ^{*2}				
				15 s ^{*2}				
8	F011	Deceleration time	0.1 s	5 s ^{*2}		0 to 3600 s	Set the deceleration time.	
				10 s ^{*2}				
				15 s ^{*2}				
9	H000 C103	Electronic thermal O/L relay	0.01 A	Inverter rated current ^{*3}		0 to 500 A	Protects the motor from heat. Set the rated motor current.	166

Pr.	Pr. group	Name	Increment	Initial value ^{*4}		Range	Application	Refer to page
				Gr.1	Gr.2			
79	D000	Operation mode selection	1	0		0 to 4, 6, 7	Select the start and frequency command sources.	142
125	T022	Terminal 2 frequency setting gain frequency	0.01 Hz	60 Hz	50 Hz	0 to 590 Hz	Change the frequency at the maximum potentiometer setting (5 V in the initial setting).	37, 248
126	T042	Terminal 4 frequency setting gain frequency	0.01 Hz	60 Hz	50 Hz	0 to 590 Hz	Change the frequency at the maximum current input (20 mA in the initial setting).	40, 248
160	E440	User group read selection	1	0		0, 1, 9999	This function restricts the parameters that are read by the operation panel and parameter unit.	117
998	E430	PM parameter initialization	1	0		0, 3044, 3144, 8009, 8109, 9009, 9109	Select the PM sensorless vector control and set the parameters that are required to drive a PM motor.	77
999	E431	Automatic parameter setting	1	9999		10, 12, 20, 21, 9999	Changes parameter settings as a batch. The target parameters include communication parameters for the Mitsubishi Electric human machine interface (GOT) connection and the parameters for the rated frequency settings of 50/60 Hz.	115

*1 Differs depending on the capacity.

6%: FR-D820-0.75K-042 or lower, FR-D840-0.75K-022 or lower, FR-D820S-0.75K-042 or lower, and FR-D810W-0.75K-042 or lower

4%: FR-D820-1.5K-070 to FR-D820-3.7K-165, FR-D840-1.5K-037 to FR-D840-3.7K-081, and FR-D820S-1.5K-070 or higher

3%: FR-D820-5.5K-238, FR-D820-7.5K-318, FR-D840-5.5K-120, and FR-D840-7.5K-163

2%: FR-D820-11K-450 or higher, FR-D840-11K-230 or higher

*2 Differs depending on the capacity.

5 s: FR-D820-3.7K-165 or lower, FR-D840-3.7K-081 or lower, FR-D820S-2.2K-100 or lower, and FR-D810W-0.75K-042 or lower

10 s: FR-D820-5.5K-238, FR-D820-7.5K-318, FR-D840-5.5K-120, and FR-D840-7.5K-163

15 s: FR-D820-11K-450 or higher, FR-D840-11K-230 or higher

*3 The initial value for the FR-D820-0.75K-042 or lower, the FR-D840-0.75K-022 or lower, FR-D820S-0.75K-042 or lower, the FR-D810W-0.75K-042 or lower is set to the 85% of the inverter rated current.

*4 Gr.1 and Gr.2 are the parameter initial value groups. (Refer to [page 46](#).)

2.5 Basic operation procedure (PU operation)

Select a method to give the frequency command from the list below, and refer to the specified page for its procedure.

Method to give the frequency command	Refer to page
Setting the frequency on the operation panel in the frequency setting mode	24
Setting the frequency by turning ON/OFF switches wired to terminals	26
Setting the frequency by inputting voltage signals	27
Setting the frequency by inputting current signals	29

2.5.1 Setting the frequency on the operation panel (example: operating at 30 Hz)

Point

- Use the operation panel to give a start command and a frequency command. (PU operation)
- Set "0 (initial value)" (PU operation mode) in **Pr.79 Operation mode selection**.

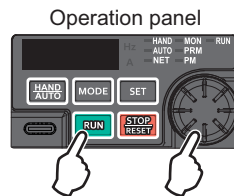

The following shows the procedure to operate at 30 Hz.

Operating procedure

- 1.** Turning ON the power of the inverter
The operation panel is in the monitor mode.
- 2.** Changing the operation mode
Press the HAND/AUTO key to choose the PU operation mode. The HAND LED turns ON.
- 3.** Setting the frequency
Turn the setting dial until the target frequency "30.00" (30.00 Hz) appears. The indication blinks for about 5 seconds. While the value is blinking, press the SET key to enter the frequency. "F" and "30.00" are displayed alternately. After about 3 seconds of alternate display, the indication returns to "0.00" (the indication of a monitored value). (If the SET key is not pressed, the indication of the value returns to "0.00" (0.00 Hz) after about 5 seconds of blinking. In that case, turn the setting dial and set the frequency again.)
- 4.** Start → acceleration → constant speed
Press the RUN key to start running. Forward rotation is performed when "0 (initial value)" is set in **Pr.40 RUN key rotation direction selection**, and reverse rotation is performed when "1" is set. The frequency value on the monitor increases according to the setting of **Pr.7 Acceleration time**, and "30.00" (30.00 Hz) appears on the monitor. (To change the set frequency, return to step 3. The previously set frequency appears.)
- 5.** Deceleration → stop
Press the STOP/RESET key to stop. The frequency value on the monitor decreases according to the setting of **Pr.8 Deceleration time**, "0.00" (0.00 Hz) appears on the monitor, and the motor stops rotating.

NOTE

- To display the set frequency, press the setting dial while the inverter runs in the PU operation mode or in the External/PU combined operation mode 1 (**Pr.79** = "3"). (Refer to [page 208](#).)
- The frequency can be set without pressing the SET key when **Pr.161 Frequency setting/key lock operation selection** = "1 or 11". (Refer to [page 104](#).)
- Operation is possible also when **Pr.79** = "1".

Parameters referred to

Pr.7 Acceleration time, Pr.8 Deceleration time  [page 130](#)

Pr.79 Operation mode selection  [page 142](#)

2.5.2 Setting the frequency with switches (multi-speed setting)

Point

- Use the RUN key on the operation panel to give a start command.
- Turn ON the RH, RM, or RL signal to give a frequency command (multi-speed setting).
- Set **Pr.79 Operation mode selection** = "4" (External/PU combined operation mode 2).

[Connection diagram]

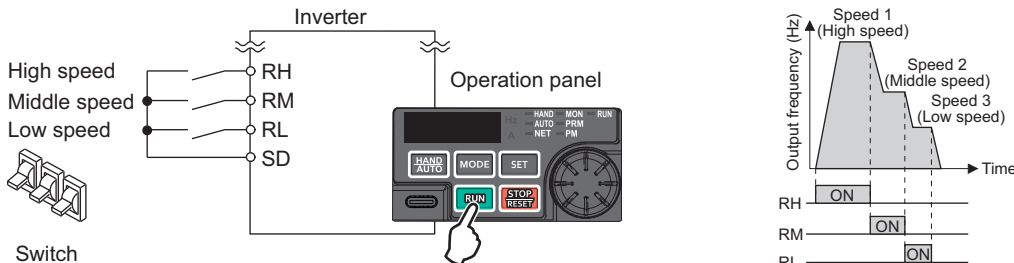

The following shows the procedure to operate at a low speed (10 Hz).

Operating procedure

- 1.** Turning ON the power of the inverter
The operation panel is in the monitor mode.
- 2.** Changing the operation mode
Set "4" in **Pr.79**. The HAND LED and AUTO LED turn ON. (To change the setting, refer to [page 21](#).)
- 3.** Setting the frequency
Turn ON the low-speed switch (RL signal).
- 4.** Start → acceleration → constant speed
Press the RUN key to start running. Forward rotation is performed when "0 (initial value)" is set in **Pr.40 RUN key rotation direction selection**, and reverse rotation is performed when "1" is set. The frequency value on the monitor increases according to the setting of **Pr.7 Acceleration time**, and "10.00" (10.00 Hz) appears on the monitor.
- 5.** Deceleration → stop
Press the STOP/RESET key to stop. The frequency value on the monitor decreases according to the setting of **Pr.8 Deceleration time**, "0.00" (0.00 Hz) appears on the monitor, and the motor stops rotating. Turn OFF the low-speed switch (RL signal).

NOTE

- The initial value is 60 Hz for terminal RH in Group 1 (50 Hz in Group 2), 30 Hz for terminal RM, and 10 Hz for terminal RL. (To change the settings, use **Pr.4**, **Pr.5**, and **Pr.6**, respectively.)
- In the initial setting, if two or more speed switches (signals) are simultaneously turned ON, priority is given to the switch (signal) for the lower speed. For example, when both RH and RM signals turn ON, the RM signal (**Pr.5**) has the higher priority.
- Up to 15-speed switching operation can be performed.

Parameters referred to

Pr.4 to Pr.6 Multi-speed setting [page 163](#)

Pr.7 Acceleration time, Pr.8 Deceleration time [page 130](#)

Pr.79 Operation mode selection [page 142](#)

2.5.3 Setting the frequency using an analog signal (voltage input)

Point

- Use the RUN key on the operation panel to give a start command.
- Use the frequency setting potentiometer to give a frequency command (by connecting it to terminals 2 and 5 (voltage input)).
- Set **Pr.79 Operation mode selection** = "4" (External/PU combined operation mode 2).

[Connection diagram] (The inverter supplies 5 V power to the frequency setting potentiometer via terminal 10.)

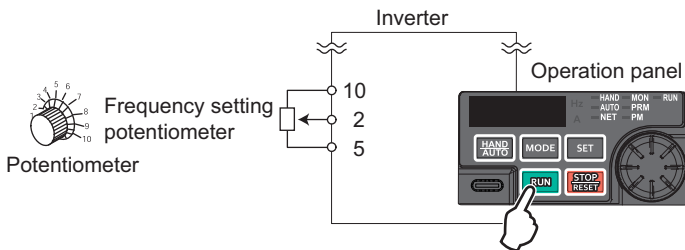

The following shows the procedure to operate at 60 Hz.

Operating procedure

1. Turning ON the power of the inverter
The operation panel is in the monitor mode.
2. Changing the operation mode
Set "4" in **Pr.79**. The HAND LED and AUTO LED turn ON. (To change the setting, refer to [page 21](#).)
3. Start
Press the RUN key. The RUN LED blinks as no frequency command is given.
4. Acceleration → constant speed
Turn the frequency setting potentiometer clockwise slowly to full. Forward rotation is performed when "0 (initial value)" is set in **Pr.40 RUN key rotation direction selection**, and reverse rotation is performed when "1" is set. The frequency value on the monitor increases according to the setting of **Pr.7 Acceleration time**, and "60.00" (60.00 Hz) appears on the monitor.
5. Deceleration
Turn the frequency setting potentiometer counterclockwise slowly to full. The frequency value on the monitor decreases according to the setting of **Pr.8 Deceleration time**, "0.00" (0.00 Hz) appears on the monitor, and the motor stops rotating. The RUN LED blinks.
6. Stop
Press the STOP/RESET key. The RUN LED turns OFF.

NOTE

- To change the frequency (60 Hz) at the maximum voltage input (initial value: 5 V), adjust **Pr.125 Terminal 2 frequency setting gain frequency**.
- To change the frequency (0 Hz) at the minimum voltage input (initial value: 0 V), adjust the calibration parameter **C2 (Pr.902) Terminal 2 frequency setting bias frequency**.
- When terminal 10 is used, the maximum output frequency may fluctuate in a range of ± 6 Hz due to fluctuations in the output voltage ($5\text{ V} \pm 0.5\text{ VDC}$). Use **Pr.125** or **C4 (Pr.903)** to adjust the output frequency at the maximum analog input as required. (Refer to [page 248](#).)

«Parameters referred to»

Pr.7 Acceleration time, Pr.8 Deceleration time  page 130

Pr.79 Operation mode selection  page 142

Pr.125 Terminal 2 frequency setting gain frequency  page 248

C2 (Pr.902) Terminal 2 frequency setting bias frequency  page 248

2.5.4 Setting the frequency using an analog signal (current input)

Point

- Use the RUN key on the operation panel to give a start command.
- Use the current regulator which outputs 4 to 20 mA to give a frequency command (by connecting it across terminals 4 and 5 (current input)).
- Turn ON the AU signal.
- Set **Pr.79 Operation mode selection** = "4" (External/PU combined operation mode 2).

[Connection diagram]

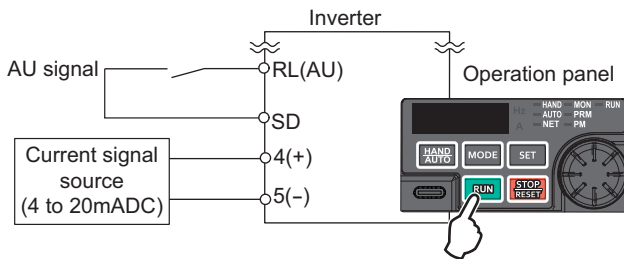

The following shows the procedure to operate at 60 Hz.

Operating procedure

- 1.** Turning ON the power of the inverter
The operation panel is in the monitor mode.
- 2.** Changing the operation mode
Set "4" in **Pr.79**. The HAND LED and AUTO LED turn ON. (To change the setting, refer to [page 21](#).)
- 3.** Assignment of AU signal
Set **Pr.180 RL terminal function selection** = "4" to assign the AU signal to terminal RL.
- 4.** Selecting the input via terminal 4
Turn ON the Terminal 4 input selection (AU) signal. Input via terminal 4 to the inverter is enabled.
- 5.** Start
Press the RUN key. The RUN LED blinks as no frequency command is given.
- 6.** Acceleration → constant speed
Input a current of 20 mA to the inverter from the regulator. Forward rotation is performed when "0 (initial value)" is set in **Pr.40 RUN key rotation direction selection**, and reverse rotation is performed when "1" is set. The frequency value on the monitor increases according to the setting of **Pr.7 Acceleration time**, and "60.00" (60.00 Hz) appears on the monitor.
- 7.** Deceleration
Input a current of 4 mA or less. The frequency value on the monitor decreases according to the setting of **Pr.8 Deceleration time**, "0.00" (0.00 Hz) appears on the monitor, and the motor stops rotating. The RUN LED blinks.
- 8.** Stop
Press the STOP/RESET key. The RUN LED turns OFF.

NOTE

- The AU signal can be assigned to another terminal. Set "4" in any parameter from **Pr.178 to Pr.182** and **Pr.185 to Pr.189 (Input terminal function selection)** to assign the function to an input terminal.
- To change the frequency (60 Hz) at the maximum current input (initial value: 20 mA), adjust **Pr.126 Terminal 4 frequency setting gain frequency**.
- To change the frequency (0 Hz) at the minimum current input (initial value: 4 mA), adjust the calibration parameter **C5 (Pr.904) Terminal 4 frequency setting bias frequency**.

« Parameters referred to »

Pr.7 Acceleration time, Pr.8 Deceleration time  [page 130](#)

Pr.79 Operation mode selection  [page 142](#)

Pr.126 Terminal 4 frequency setting gain frequency  [page 248](#)

Pr.178 to Pr.182 and Pr.185 to Pr.189 (Input terminal function selection)  [page 252](#)

C5 (Pr.904) Terminal 4 frequency setting bias frequency  [page 248](#)

2.6 Basic operation procedure (External operation)

Select a method to give the frequency command from the list below, and refer to the specified page for its procedure.

Method to give the frequency command	Refer to page
Setting the frequency on the operation panel in the frequency setting mode	31
Giving frequency commands with switches (multi-speed setting)	33
Setting the frequency by inputting voltage signals	35
Setting the frequency by inputting current signals	38

2.6.1 Setting the frequency on the operation panel

Point

- Turn ON the STF/STR signal to give a start command.
- Use operation panel (setting dial) to give a frequency command.
- Set **Pr.79 Operation mode selection** = "3" (External/PU combined operation mode 1).

[Connection diagram]

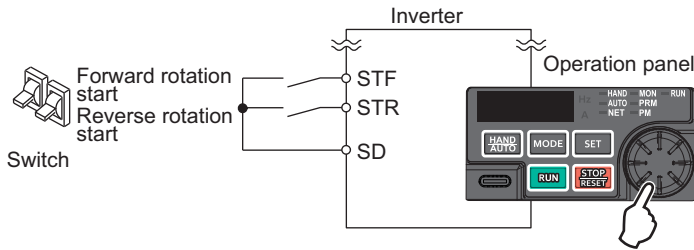

The following shows the procedure to operate at 30 Hz.

Operating procedure

1. Turning ON the power of the inverter
The operation panel is in the monitor mode.
2. Changing the operation mode
Set "3" in **Pr.79**. The HAND LED and AUTO LED turn ON. (To change the setting, refer to [page 21](#).)
3. Setting the frequency
Turn the setting dial until the target frequency "30.00" (30.00 Hz) appears. The indication blinks for about 5 seconds. While the value is blinking, press the SET key to enter the frequency. "F" and "30.00" are displayed alternately. After about 3 seconds of alternate display, the indication returns to "0.00" (the indication of a monitored value). (If the SET key is not pressed, the indication of the value returns to "0.00" (0.00 Hz) after about 5 seconds of blinking. In that case, turn the setting dial and set the frequency again.)
4. Start → acceleration → constant speed
Turn ON the start switch (STF/STR signal). The frequency value on the monitor increases according to the setting of **Pr.7 Acceleration time**, and "30.00" (30.00 Hz) appears on the monitor. The RUN LED is ON during forward rotation and blinks slowly during reverse rotation. (To change the set frequency, return to step 2. The previously set frequency appears.)
5. Deceleration → stop
Turn OFF the start switch (STF/STR signal). The frequency value on the monitor decreases according to the setting of **Pr.8 Deceleration time**, "0.00" (0.00 Hz) appears on the monitor, and the motor stops rotating.

NOTE

- When both the forward rotation start switch (STF signal) and the reverse rotation start switch (STR signal) are turned ON, the motor cannot be started. If both are turned ON while the inverter is running, the inverter decelerates to a stop.
- **Pr.178 STF terminal function selection** must be set to "60" (or **Pr.179 STR terminal function selection** must be set to "61") (initial value).
- Setting **Pr.79 Operation mode selection** = "3" enables multi-speed operation.
- If the STOP/RESET key on the operation panel is pressed during the External operation, the inverter stops and the PU stop warning is activated ("PS" appears on the LCD display of the operation panel.) To reset the PU stop warning, turn OFF the start switch (STF or STR signal), and then press the HAND/AUTO key. (Refer to [page 99](#).)

Parameters referred to

Pr.4 to Pr.6 Multi-speed setting [page 163](#), **Pr.7 Acceleration time, Pr.8 Deceleration time** [page 130](#)

Pr.178 STF terminal function selection, Pr.179 STR terminal function selection [page 252](#)

Pr.79 Operation mode selection [page 142](#)

2.6.2 Setting the frequency and giving a start command with switches (multi-speed setting)

Point

- Turn ON the STF/STR signal to give a start command.
- Turn ON the RH, RM, or RL signal to give a frequency command (multi-speed setting).
- Set **Pr.79 Operation mode selection** = "0 (initial value)" (External operation mode).

[Connection diagram]

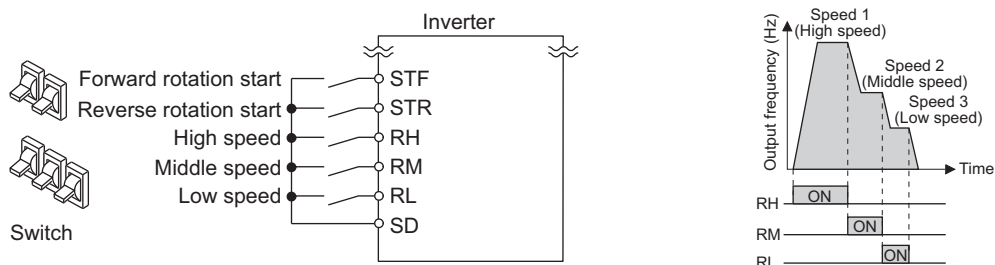

The following shows the procedure to operate at a high speed (60 Hz).

Operating procedure

1. Turning ON the power of the inverter
The operation panel is in the monitor mode.
2. Setting the frequency
Turn ON the high-speed switch (RH signal).
3. Start → acceleration → constant speed
Turn ON the start switch (STF/STR signal). The frequency value on the monitor increases according to the setting of **Pr.7 Acceleration time**, and "60.00" (60.00 Hz) appears on the monitor. The RUN LED is ON during forward rotation and blinks slowly during reverse rotation. When the RM signal is turned ON, 30 Hz is displayed. When the RL signal is turned ON, 10 Hz is displayed.
4. Deceleration → stop
Turn OFF the start switch (STF/STR signal). The frequency value on the monitor decreases according to the setting of **Pr.8 Deceleration time**, "0.00" (0.00 Hz) appears on the monitor, and the motor stops rotating. The RUN LED turns OFF. Turn OFF the high-speed switch (RH signal).

NOTE

- When both the forward rotation start switch (STF signal) and the reverse rotation start switch (STR signal) are turned ON, the motor cannot be started. If both are turned ON while the inverter is running, the inverter decelerates to a stop.
- The initial value is 60 Hz for terminal RH in Group 1 (50 Hz in Group 2), 30 Hz for terminal RM, and 10 Hz for terminal RL. (To change the settings, use **Pr.4**, **Pr.5**, and **Pr.6**, respectively.)
- In the initial setting, if two or more speed switches (signals) are simultaneously turned ON, priority is given to the switch (signal) for the lower speed. For example, when both RH and RM signals turn ON, the RM signal (**Pr.5**) has the higher priority.
- Up to 15-speed switching operation can be performed.
- When the PU operation mode is selected while **Pr.79** = "0", the operation mode must be returned to the External operation mode.
- Operation is possible also when **Pr.79** = "2".

«Parameters referred to»

Pr.4 to Pr.6 Multi-speed setting  [page 163](#)

Pr.7 Acceleration time, Pr.8 Deceleration time  [page 130](#)

2.6.3 Setting the frequency using an analog signal (voltage input)

Point

- Turn ON the STF/STR signal to give a start command.
- Use the frequency setting potentiometer to give a frequency command (by connecting it to terminals 2 and 5 (voltage input)).
- Set **Pr.79 Operation mode selection** = "0 (initial value)" (External operation mode).

[Connection diagram] (The inverter supplies 5 V power to the frequency setting potentiometer via terminal 10.)

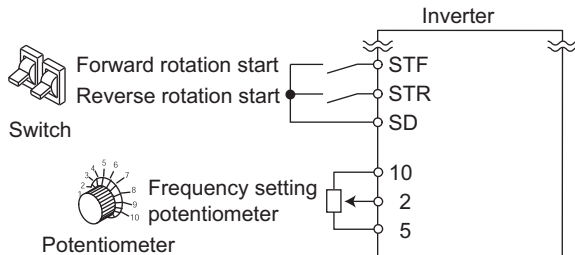

The following shows the procedure to operate at 60 Hz.

Operating procedure

- 1.** Turning ON the power of the inverter
The operation panel is in the monitor mode.
- 2.** Start
Turn ON the start switch (STF/STR signal). The RUN LED on the operation panel blinks as no frequency command is given.
- 3.** Acceleration → constant speed
Turn the frequency setting potentiometer clockwise slowly to full. The frequency value on the monitor increases according to the setting of **Pr.7 Acceleration time**, and "60.00" (60.00 Hz) appears on the monitor. The RUN LED is ON during forward rotation and blinks slowly during reverse rotation.
- 4.** Deceleration
Turn the frequency setting potentiometer counterclockwise slowly to full. The frequency value on the monitor decreases according to the setting of **Pr.8 Deceleration time**, "0.00" (0.00 Hz) appears on the monitor, and the motor stops rotating. The RUN LED blinks.
- 5.** Stop
Turn OFF the start switch (STF/STR signal). The RUN LED turns OFF.

NOTE

- When both the forward rotation start switch (STF signal) and the reverse rotation start switch (STR signal) are turned ON, the motor cannot be started. If both are turned ON while the inverter is running, the inverter decelerates to a stop.
- **Pr.178 STF terminal function selection** must be set to "60" (or **Pr.179 STR terminal function selection** must be set to "61") (initial value).
- When terminal 10 is used, the maximum output frequency may fluctuate in a range of ± 6 Hz due to fluctuations in the output voltage (5 ± 0.5 VDC). Use **Pr.125** or **C4 (Pr.903)** to adjust the output frequency at the maximum analog input as required. (Refer to [page 248](#).)
- When the PU operation mode is selected while **Pr.79** = "0", the operation mode must be returned to the External operation mode.
- Operation is possible also when **Pr.79** = "2".

«Parameters referred to»

Pr.7 Acceleration time, Pr.8 Deceleration time  [page 130](#)

Pr.178 STF terminal function selection, Pr.179 STR terminal function selection  [page 252](#)

2.6.4 Changing the frequency (initial value: 60 Hz) at the maximum voltage input (initial value: 5 V)

Point

- Change the maximum frequency.

The following shows the procedure to change the frequency at 5 V from 60 Hz (initial value) to 50 Hz using a frequency setting potentiometer for 0 to 5 VDC input. Set 50 Hz in **Pr.125** so that the inverter outputs 50 Hz at 5 V input.

Operating procedure

- 1.** Selecting the parameter
 Turn the setting dial until "P.125" (**Pr.125**) appears.
 Press the SET key to show the present set value (60.00 Hz).
- 2.** Changing the maximum frequency
 Turn the setting dial to change the value to "50.00" (50.00 Hz).
 Press the SET key to confirm the setting. "50.00" blinks.
- 3.** Selecting the mode and the monitor item
 Press the MODE key twice to select the monitor mode and to monitor a frequency.
- 4.** Start
 Turn ON the start switch (STF/STR signal), and turn the frequency setting potentiometer clockwise slowly to full.
 (Refer to steps 2 and 3 in [page 35.](#))
 The motor is operated at 50 Hz.

NOTE

- To set the frequency at 0 V, use the calibration parameter **C2 (Pr.902)**.

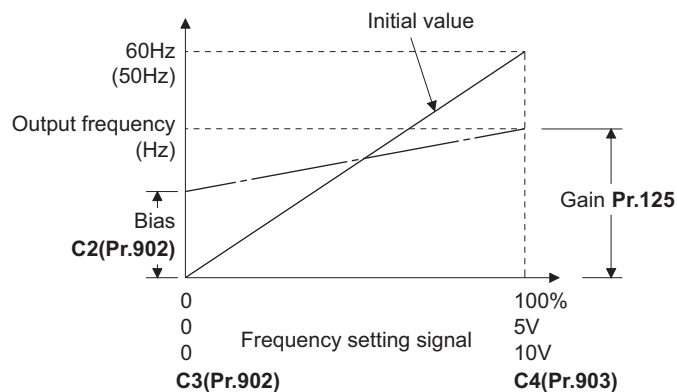

- Other adjustment methods for the frequency setting voltage gain are the following: adjustment by applying a voltage directly across terminals 2 and 5, and adjustment using a specified point without applying a voltage across terminals 2 and 5. (Refer to [page 248.](#))

Parameters referred to

Pr.125 Terminal 2 frequency setting gain frequency [page 248](#)

C2 (Pr.902) Terminal 2 frequency setting bias frequency [page 248](#)

C4 (Pr.903) Terminal 2 frequency setting gain [page 248](#)

2.6.5 Setting the frequency using an analog signal (current input)

Point

- Turn ON the STF/STR signal to give a start command.
- Use the current regulator which outputs 4 to 20 mA to give a frequency command (by connecting it across terminals 4 and 5 (current input)).
- Turn ON the AU signal.
- Set **Pr.79 Operation mode selection** = "0 (initial value)" (External operation mode).

[Connection diagram]

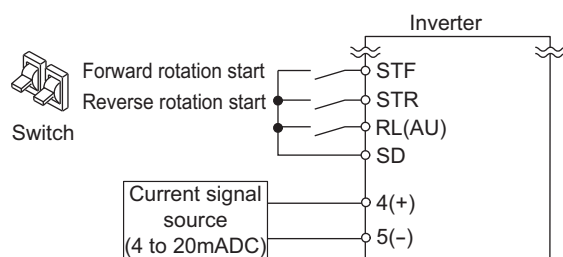

The following shows the procedure to operate at 60 Hz.

Operating procedure

- 1.** Turning ON the power of the inverter
The operation panel is in the monitor mode.
- 2.** Changing the operation mode
Press the HAND/AUTO key to choose the PU operation mode. The HAND LED turns ON.
- 3.** Assignment of AU signal
Set **Pr.180 RL terminal function selection** = "4" to assign the AU signal to terminal RL. (To change the setting, refer to [page 17.](#))
- 4.** Changing the operation mode
Press the HAND/AUTO key to choose the External operation mode. The AUTO LED turns ON.
- 5.** Selecting the input via terminal 4
Turn ON the Terminal 4 input selection (AU) signal. Input via terminal 4 to the inverter is enabled.
- 6.** Start
Turn ON the start switch (STF/STR signal). The RUN LED blinks as no frequency command is given.
- 7.** Acceleration → constant speed
Input a current of 20 mA to the inverter from the regulator. The frequency value on the monitor increases according to the setting of **Pr.7 Acceleration time**, and "60.00" (60.00 Hz) appears on the monitor. The RUN LED is ON during forward rotation and blinks slowly during reverse rotation.
- 8.** Deceleration
Input a current of 4 mA or less. The frequency value on the monitor decreases according to the setting of **Pr.8 Deceleration time**, "0.00" (0.00 Hz) appears on the monitor, and the motor stops rotating. The RUN LED blinks.
- 9.** Stop
Turn OFF the start switch (STF/STR signal). The RUN LED turns OFF.

NOTE

- When both the forward rotation start switch (STF signal) and the reverse rotation start switch (STR signal) are turned ON, the motor cannot be started. If both are turned ON while the inverter is running, the inverter decelerates to a stop.
- The AU signal can be assigned to another terminal. Set "4" in any parameter from **Pr.178 to Pr.182 and Pr.185 to Pr.189 (Input terminal function selection)** to assign the function to an input terminal.
- Operation is possible also when **Pr.79 = "2"**.

2

Parameters referred to

Pr.7 Acceleration time, Pr.8 Deceleration time  [page 130](#)

Pr.178 to Pr.182 and Pr.185 to Pr.189 (Input terminal function selection)  [page 252](#)

2.6.6 Changing the frequency (initial value: 60 Hz) at the maximum current input (initial value: 20 mA)

Point

- Change the maximum frequency.

The following shows the procedure to change the frequency at 20 mA from 60 Hz (initial value) to 50 Hz using a frequency setting potentiometer for 4 to 20 mA input. Set 50 Hz in **Pr.126** so that the inverter outputs 50 Hz at 20 mA input.

Operating procedure

- 1.** Selecting the parameter
 Turn the setting dial until "P.126" (**Pr.126**) appears.
 Press the SET key to show the present set value (60.00 Hz).
- 2.** Changing the maximum frequency
 Turn the setting dial to change the value to "50.00" (50.00 Hz).
 Press the SET key to confirm the setting. "50.00" blinks.
- 3.** Selecting the mode and the monitor item
 Press the MODE key twice to select the monitor mode and to monitor a frequency.
- 4.** Start
 Turn ON the start switch (STF or STR) to apply a 20 mA current. (Refer to steps 6 and 7 in [page 38](#).)
 The motor is operated at 50 Hz.

NOTE

- To set the frequency at 4 mA, use the calibration parameter **C5 (Pr.904)**.

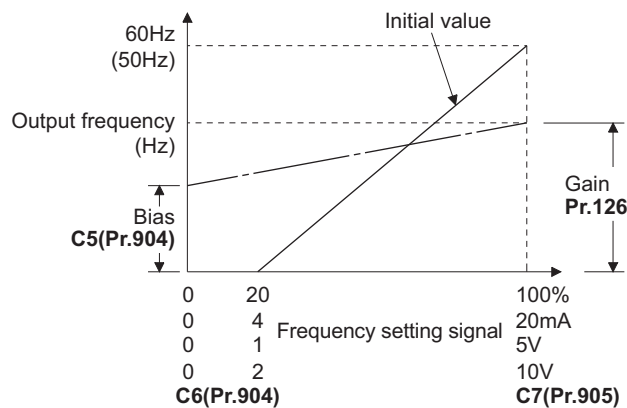

- Other adjustment methods for the frequency setting current gain are the following: adjustment by applying a current through terminals 4 and 5, and adjustment using a specified point without applying a current through terminals 4 and 5. (Refer to [page 248](#).)

Parameters referred to

Pr.126 Terminal 4 frequency setting gain frequency [page 248](#)

C5 (Pr.904) Terminal 4 frequency setting bias frequency [page 248](#)

C7 (Pr.905) Terminal 4 frequency setting gain [page 248](#)

2.7 Basic operation procedure (JOG operation)

2.7.1 Giving a start command by using external signals for JOG operation

Point

- The JOG signal can be input only via a control circuit terminal.
- JOG operation is performed while the JOG signal is ON.
- Use **Pr.15 Jog frequency** to set a frequency, and set **Pr.16 Jog acceleration/deceleration time** to set the acceleration/deceleration time for JOG operation.
- Set **Pr.79 Operation mode selection** = "0 (initial value)" (External operation mode).

[Connection diagram]

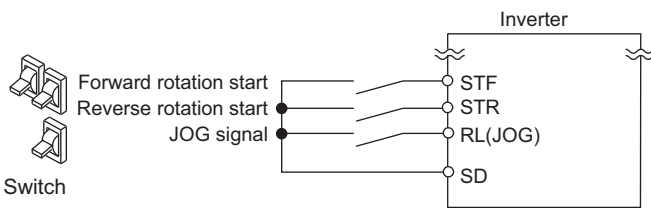

The following shows the procedure to operate at 5 Hz.

Operating procedure

- 1.** Turning ON the power of the inverter
The operation panel is in the monitor mode.
- 2.** Changing the operation mode
Press the HAND/AUTO key to choose the PU operation mode. The HAND LED turns ON.
- 3.** Assignment of JOG signal
Set **Pr.180 RL terminal function selection** = "5" to assign the JOG signal to terminal RL. (To change the setting, refer to [page 17](#).)
- 4.** Changing the operation mode
Press the HAND/AUTO key to choose the External operation mode. The AUTO LED turns ON.
- 5.** Turning ON the JOG signal
Turn ON the JOG switch (JOG signal). The inverter is set ready for the JOG operation.
- 6.** Start → acceleration → constant speed
Turn ON the start switch (STF/STR signal). The frequency value on the monitor increases according to the setting of **Pr.16 Jog acceleration/deceleration time**, and "5.00" (5.00 Hz) appears on the monitor. The RUN LED is ON during forward rotation and blinks slowly during reverse rotation.
- 7.** Deceleration → stop
Turn OFF the start switch (STF/STR signal). The frequency value on the monitor decreases according to the setting of **Pr.16 Jog acceleration/deceleration time**, "0.00" (0.00 Hz) appears on the monitor, and the motor stops rotating. The RUN LED turns OFF. Turn OFF the JOG switch (JOG signal).

NOTE

- To change the frequency, change the setting of **Pr.15 Jog frequency** (initial value: 5 Hz).
- To change the acceleration/deceleration time, change the setting of **Pr.16 Jog acceleration/deceleration time** (initial value: 0.5 second).
- The JOG signal can be assigned to another terminal. Set "5" in any parameter from **Pr.178 to Pr.182 (Input terminal function selection)** to assign the function to an input terminal.
- The JOG2 signal enables the JOG operation via communication. (Refer to [page 161](#).)
- Operation is possible also when **Pr.79** = "2".

«Parameters referred to»

Pr.15 Jog frequency, Pr.16 Jog acceleration/deceleration time  [page 161](#)

Pr.79 Operation mode selection  [page 142](#)

Pr.178 to Pr.182 and Pr.185 to Pr.189 (Input terminal function selection)  [page 252](#)

2.7.2 Giving a start command from the operation panel for JOG operation

Point

- JOG operation is performed while the RUN key on the operation panel is pressed.

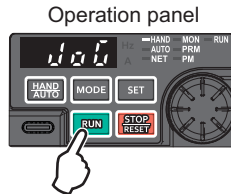

The following shows the procedure to operate at 5 Hz.

Operating procedure

1. Turning ON the power of the inverter
The operation panel is in the monitor mode.
2. Changing the operation mode
Press the HAND/AUTO key twice to choose the PUJOG operation mode. The display shows "JOG", and the HAND LED is ON.
3. Start → acceleration → constant speed
Hold down the RUN key. Forward rotation is performed when "0 (initial value)" is set in **Pr.40 RUN key rotation direction selection**, and reverse rotation is performed when "1" is set. The frequency value on the monitor increases according to the setting of **Pr.16 Jog acceleration/deceleration time**, and "5.00" (5.00 Hz) appears on the monitor.
4. Deceleration → stop
Release the RUN key. The frequency value on the monitor decreases according to the setting of **Pr.16 Jog acceleration/deceleration time**, "0.00" (0.00 Hz) appears on the monitor, and the motor stops rotating.

NOTE

- To change the frequency, change the setting of **Pr.15 Jog frequency** (initial value: 5 Hz).
- To change the acceleration/deceleration time, change the setting of **Pr.16 Jog acceleration/deceleration time** (initial value: 0.5 second).

Parameters referred to

Pr.15 Jog frequency, **Pr.16 Jog acceleration/deceleration time**  [page 161](#)

2.8 I/O terminal function assignment

- Functions can be assigned to the external I/O terminals (physical terminals) or communication (virtual terminals) by setting parameters.

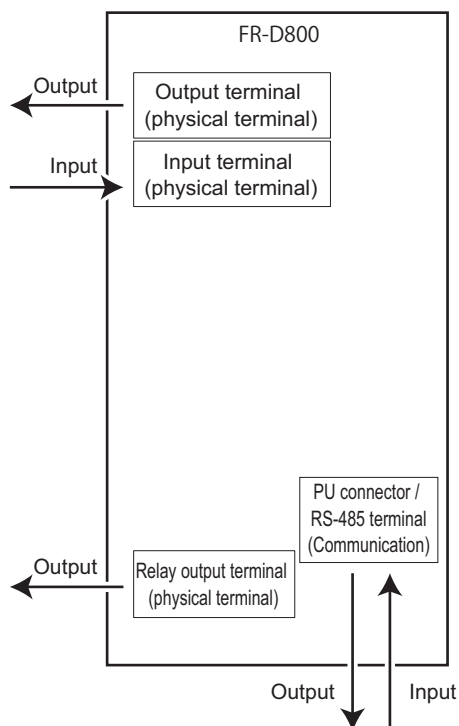

◆ Input terminal function assignment

- Signals can be input to the inverter by using physical terminals or via communication.
- Use parameters to assign functions to input terminals. Check the terminal available for each parameter.

Pr.	Terminal name	External input terminal (physical terminal)	Input via communication ^{*1}
178	STF	○	Forward rotation command only
179	STR	○	Reverse rotation command only
180	RL	○	○
181	RM	○	○
182	RH	○	○
185	NET X1	—	○
186	NET X2	—	○
187	NET X3	—	○
188	NET X4	—	○
189	NET X5	—	○

○: Assignment/input available, —: Assignment/input unavailable (no function)

^{*1} The communication protocol affects which terminals can be used. For details, refer to the Instruction Manual (Communication).

NOTE

- For the available signals, refer to [page 252](#).

◆ Output terminal function assignment

- Signals can be output from the inverter by using physical terminals or via communication
- Use parameters to assign functions to output terminals. Check the terminal available for each parameter.

Pr.	Terminal name	External output terminal (physical terminal)	Output via communication ^{*1}
190	RUN	○	○
191	R+/FU	○ ^{*2}	○
192	A,B,C	○	○
193	NET Y1	—	○
194	NET Y2	—	○
195	NET Y3	—	○
196	NET Y4	—	○

○: Assignment/input available, —: Assignment/input unavailable (no function)

*1 The communication protocol affects which terminals can be used. For details, refer to the Instruction Manual (Communication).

*2 When the R+/FU switch (SW5) is set to the upper position (FU) (initial status), the assigned function is enabled. Assignment is not available when the RS-485 terminals are used for RS-485 communication. For details, refer to the Instruction Manual (Connection) and the Instruction Manual (Communication).

NOTE



- For the available signals, refer to [page 226](#).

3 Parameters

This chapter explains the function setting for use of this product.

Always read the instructions before use.

The following marks are used to indicate the controls. (Parameters without any mark are valid for all the controls.)

Mark	Control method	Applied motor
	V/F control	Three-phase induction motor
	Advanced magnetic flux vector control	
	PM sensorless vector control	PM motor

3.1 Parameter initial value groups

- Initial values of parameters of the FR-D800 differ depending on the parameter initial value group. In this Instruction Manual, Gr.1 indicates the parameter initial value group 1, and Gr.2 indicates the parameter initial value group 2.
- FR-D800 inverters are divided into two groups as shown in the following table.

Parameter initial value groups	Country of origin indication (on the rating plate) ^{*1}
Group 1 (Gr.1) ^{*2}	MADE IN JAPAN
Group 2 (Gr.2) ^{*2}	MADE IN CHINA

*1 The country of origin can be checked on the rating plate. (Refer to [page 9](#).)

*2 Use **Pr.GR Parameter initial value group setting** to change the parameter initial value group. (Refer to [page 356](#).)

- The initial values of the following parameters differ depending on the parameter initial value group.

Pr.	Name	Initial value		Refer to page
		Gr.1	Gr.2	
3	Base frequency	60 Hz	50 Hz	329
4	Multi-speed setting (high speed)	60 Hz	50 Hz	163
19	Base frequency voltage	9999	8888	329
20	Acceleration/deceleration reference frequency	60 Hz	50 Hz	130
55	Frequency monitoring reference	60 Hz	50 Hz	208
66	Stall prevention operation reduction starting frequency	60 Hz	50 Hz	195
125 (903)	Terminal 2 frequency setting gain frequency	60 Hz	50 Hz	248
126 (905)	Terminal 4 frequency setting gain frequency	60 Hz	50 Hz	248
249	Earth (ground) fault detection at start	0	1	175
386	Frequency for maximum input pulse	60 Hz	50 Hz	159
505	Speed setting reference	60 Hz	50 Hz	206
1013	Running speed after recovery from emergency drive undervoltage	60 Hz	50 Hz	182
1486	Load characteristics maximum frequency	60 Hz	50 Hz	200

3.2 Parameter list (by parameter number)

For simple variable-speed operation of the inverter, the initial values of the parameters may be used as they are. Set the necessary parameters to meet the load and operational specifications. Parameter's setting, change and check can be made on the operation panel.

NOTE

- **Simple** indicates simple mode parameters. Use **Pr.160 User group read selection** to indicate the simple mode parameters only (initial setting is to indicate the extended mode parameters).
- The changing of the parameter settings may be restricted in some operating status. Use **Pr.77 Parameter write selection** to change the setting of the restriction.
- Refer to [page 360](#) for instruction codes for communication, parameters under different control methods, and availability of Parameter copy, Parameter clear, and All parameter clear.

Notation

Mark	Description
[100/200 V class]	Available for the 100/200 V class.
[400 V class]	Available for the 400 V class.
[3-phase]	Available for the three-phase power input model.

◆ Pr.0 to Pr.99

Function	Pr.	Pr. group	Name	Setting range	Minimum setting increments	Initial value ^{*1}		Refer to page
						Gr.1	Gr.2	
Basic function	0	G000	Torque boost ^{Simple}	0% to 30%	0.1%	6% ^{*2} 4% ^{*2} 3% ^{*2} 2% ^{*2}		327
	1	H400	Maximum frequency ^{Simple}	0 to 120 Hz	0.01 Hz	120 Hz		191
	2	H401	Minimum frequency ^{Simple}	0 to 120 Hz	0.01 Hz	0 Hz		191
	3	G001	Base frequency ^{Simple}	0 to 590 Hz	0.01 Hz	60 Hz	50 Hz	329
	4	D301	Multi-speed setting (high speed) ^{Simple}	0 to 590 Hz	0.01 Hz	60 Hz	50 Hz	163
	5	D302	Multi-speed setting (middle speed) ^{Simple}	0 to 590 Hz	0.01 Hz	30 Hz		163
	6	D303	Multi-speed setting (low speed) ^{Simple}	0 to 590 Hz	0.01 Hz	10 Hz		163
	7	F010	Acceleration time ^{Simple}	0 to 3600 s	0.1 s	5 s ^{*3} 10 s ^{*3} 15 s ^{*3}		130
	8	F011	Deceleration time ^{Simple}	0 to 3600 s	0.1 s	5 s ^{*3} 10 s ^{*3} 15 s ^{*3}		130
	9	H000	Electronic thermal O/L relay ^{Simple}	0 to 500 A	0.01 A	Inverter rated current		166, 266, 274
	C103	Rated motor current ^{Simple}						
DC injection brake	10	G100	DC injection brake operation frequency	0 to 120 Hz	0.01 Hz	3 Hz		335
	11	G101	DC injection brake operation time	0 to 10 s	0.1 s	0.5 s		335
	12	G110	DC injection brake operation voltage	0% to 30%	0.1%	6% ^{*4} 4% ^{*4} 2% ^{*4}		335

Function	Pr.	Pr. group	Name	Setting range	Minimum setting increments	Initial value ^{*1}		Refer to page
						Gr.1	Gr.2	
—	13	F102	Starting frequency	0 to 60 Hz	0.01 Hz	0.5 Hz		139, 141
—	14	G003	Load pattern selection	0 to 3	1	0		331
JOG operation	15	D200	Jog frequency	0 to 590 Hz	0.01 Hz	5 Hz		161
	16	F002	Jog acceleration/deceleration time	0 to 3600 s	0.1 s	0.5 s		161
—	17	T720	MRS/X10 terminal input selection	0 to 5	1	0		255
—	18	H402	High speed maximum frequency	0 to 590 Hz	0.01 Hz	120 Hz		191
—	19	G002	Base frequency voltage	0 to 1000 V, 8888, 9999	0.1 V	9999	8888	329
Acceleration/deceleration time	20	F000	Acceleration/deceleration reference frequency	1 to 590 Hz	0.01 Hz	60 Hz	50 Hz	130
Stall prevention	22	H500	Stall prevention operation level (Torque limit level)	0% to 400%	0.1%	150%		87, 195
	23	H610	Stall prevention operation level compensation factor at double speed	0% to 200%, 9999	0.1%	9999		195
Multi-speed setting	24 to 27	D304 to D307	Multi-speed setting (speed 4 to speed 7)	0 to 590 Hz, 9999	0.01 Hz	9999		163
—	29	F100	Acceleration/deceleration pattern selection	0 to 2	1	0		133
—	30	E300	Regenerative function selection	0 to 2	1	0		340
Frequency jump	31	H420	Frequency jump 1A	0 to 590 Hz, 9999	0.01 Hz	9999		193
	32	H421	Frequency jump 1B	0 to 590 Hz, 9999	0.01 Hz	9999		193
	33	H422	Frequency jump 2A	0 to 590 Hz, 9999	0.01 Hz	9999		193
	34	H423	Frequency jump 2B	0 to 590 Hz, 9999	0.01 Hz	9999		193
	35	H424	Frequency jump 3A	0 to 590 Hz, 9999	0.01 Hz	9999		193
	36	H425	Frequency jump 3B	0 to 590 Hz, 9999	0.01 Hz	9999		193
—	37	M000	Speed display	0.01 to 9998	0.001	1800		206
—	40	E202	RUN key rotation direction selection	0, 1	1	0		107
Frequency detection	41	M441	Up-to-frequency sensitivity	0% to 100%	0.1%	10%		234
	42	M442	Output frequency detection	0 to 590 Hz	0.01 Hz	6 Hz		234
	43	M443	Output frequency detection for reverse rotation	0 to 590 Hz, 9999	0.01 Hz	9999		234
Second function	44	F020	Second acceleration/deceleration time	0 to 3600 s	0.1 s	5 s ^{*3}		130, 300
						10 s ^{*3}		
						15 s ^{*3}		
	45	F021	Second deceleration time	0 to 3600 s, 9999	0.1 s	9999		130, 300
	46	G010	Second torque boost	0% to 30%, 9999	0.1%	9999		327
	47	G011	Second V/F (base frequency)	0 to 590 Hz, 9999	0.01 Hz	9999		329
	48	H600	Second stall prevention operation level	0% to 400%, 9999	0.1%	9999		195
51	H010	Second electronic thermal O/L relay	0 to 500 A, 9999	0.01 A	9999		166	
	C203	Rated second motor current						

Function	Pr.	Pr. group	Name	Setting range	Minimum setting increments	Initial value*1		Refer to page
						Gr.1	Gr.2	
Monitoring	52	M100	Operation panel main monitor selection	0, 5 to 14, 17, 18, 20, 23 to 25, 32, 33, 37, 38, 44, 50 to 55, 61, 62, 64, 67, 68, 91, 97, 98, 100	1	0		208
	53	M003	Frequency / rotation speed unit switchover	0, 1, 4	1	0		206
	55	M040	Frequency monitoring reference	0 to 590 Hz	0.01 Hz	60 Hz	50 Hz	216
	56	M041	Current monitoring reference	0 to 500 A	0.01 A	Inverter rated current		216
Automatic restart	57	A702	Restart coasting time	0, 0.1 to 30 s, 9999	0.1 s	9999		307, 312
	58	A703	Restart cushion time	0 to 60 s	0.1 s	1 s		307
—	59	F101	Remote function selection	0 to 4	1	0		135
—	60	G030	Energy saving control selection	0, 9	1	0		333
—	65	H300	Retry selection	0 to 5	1	0		179
—	66	H611	Stall prevention operation reduction starting frequency	0 to 590 Hz	0.01 Hz	60 Hz	50 Hz	195
Retry	67	H301	Number of retries at fault occurrence	0 to 10, 101 to 110	1	0		179
	68	H302	Retry waiting time	0.1 to 600 s	0.1 s	1 s		179
	69	H303	Retry count display erase	0	1	0		179
—	70	G107	Special regenerative brake duty	0% to 100%	0.1%	0%		340
—	71	C100	Applied motor	0, 3, 5, 6, 10, 13, 15, 16, 20, 23, 40, 43, 50, 53, 70, 73, 1140, 8090, 8093, 9090, 9093	1	0		261, 266, 274
—	72	E600	PWM frequency selection	0 to 15	1	1		120
—	73	T000	Analog input selection	0, 1, 6, 10, 11, 16	1	1		243
—	74	T002	Input filter time constant	0 to 8	1	1		247
—	75	—	Reset selection/disconnected PU detection/PU stop selection	0 to 3, 14 to 17	1	14		97
		E100	Reset selection	0, 1		0		
		E101	Disconnected PU detection			1		
		E102	PU stop selection			1		
—	77	E400	Parameter write selection	0 to 2	1	0		109
—	78	D020	Reverse rotation prevention selection	0 to 2	1	0		158
—	79	D000	Operation mode selection <i>Simple</i>	0 to 4, 6, 7	1	0		142, 152

Function	Pr.	Pr. group	Name	Setting range	Minimum setting increments	Initial value ^{*1}		Refer to page
						Gr.1	Gr.2	
Motor constant	80	C101	Motor capacity	0.1 to 18.5 kW, 9999	0.01 kW	9999		72, 266, 274
	81	C102	Number of motor poles	2, 4, 6, 8, 10, 12, 9999	1	9999		72, 266, 274
	82	C125	Motor excitation current	0 to 500 A, 9999	0.01 A	9999		266
	83	C104	Rated motor voltage	0 to 1000 V	0.1 V	[100/200 V class] 200 V [400 V class] 400 V		72, 266, 274
	84	C105	Rated motor frequency	10 to 400 Hz, 9999	0.01 Hz	9999		72, 266, 274
	89	G932	Speed control gain (Advanced magnetic flux vector)	0% to 200%, 9999	0.1%	9999		75
	90	C120	Motor constant (R1)	0 to 50 Ω, 9999	0.001 Ω	9999		266, 274, 314
	91	C121	Motor constant (R2)	0 to 50 Ω, 9999	0.001 Ω	9999		266
	92	C122	Motor constant (L1)/d-axis inductance (Ld)	0 to 6000 mH, 9999	0.1 mH	9999		266, 274
	93	C123	Motor constant (L2)/q-axis inductance (Lq)	0 to 6000 mH, 9999	0.1 mH	9999		266, 274
	94	C124	Motor constant (X)	0% to 100%, 9999	0.1%	9999		266
	96	C110	Auto tuning setting/status	0, 1, 11	1	0		266, 274, 314

◆ Pr.100 to Pr.199

Function	Pr.	Pr. group	Name	Setting range	Minimum setting increments	Initial value*1		Refer to page
						Gr.1	Gr.2	
RS-485 communication	117	N020	RS-485 communication station number	0 to 31 (0 to 247)	1	0		*6
	118	N021	RS-485 communication speed	48, 96, 192, 384, 576, 768, 1152	1	192		*6
	119	—	RS-485 communication stop bit length / data length	0, 1, 10, 11	1	1		*6
		N022	RS-485 communication data length	0, 1		0		
		N023	RS-485 communication stop bit length	0, 1		1		
	120	N024	RS-485 communication parity check	0 to 2	1	2		*6
	121	N025	RS-485 communication retry count	0 to 10, 9999	1	1		*6
	122	N026	RS-485 communication check time interval	0, 0.1 to 999.8 s, 9999	0.1 s	0		*6
	123	N027	RS-485 communication waiting time setting	0 to 150 ms, 9999	1 ms	9999		*6
	124	N028	RS-485 communication CR/LF selection	0 to 2	1	1		*6
—	125	T022	Terminal 2 frequency setting gain frequency <i>Simple</i>	0 to 590 Hz	0.01 Hz	60 Hz	50 Hz	248
—	126	T042	Terminal 4 frequency setting gain frequency <i>Simple</i>	0 to 590 Hz	0.01 Hz	60 Hz	50 Hz	248
PID operation	127	A612	PID control automatic switchover frequency	0 to 590 Hz, 9999	0.01 Hz	9999		283
	128	A610	PID action selection	0, 20, 21, 40 to 43, 1000, 1001, 1010, 1011, 2000, 2001, 2010, 2011	1	0		283, 300
	129	A613	PID proportional band	0.1% to 1000%, 9999	0.1%	100%		283, 300
	130	A614	PID integral time	0.1 to 3600 s, 9999	0.1 s	1 s		283, 300
	131	A601	PID upper limit	0% to 100%, 9999	0.1%	9999		283, 300
	132	A602	PID lower limit	0% to 100%, 9999	0.1%	9999		283, 300
	133	A611	PID action set point	0% to 100%, 9999	0.01%	9999		283, 300
	134	A615	PID differential time	0.01 to 10 s, 9999	0.01 s	9999		283, 300
—	136	A001	MC switchover interlock time	0 to 100 s	0.1 s	1 s		182
—	139	A004	Automatic switchover frequency from inverter to bypass operation	0 to 60 Hz, 9999	0.01 Hz	9999		182
PU	145	E103	PU display language selection	0 to 7	1	—		100
Current detection	150	M460	Output current detection level	0% to 400%	0.1%	150%		237
	151	M461	Output current detection signal delay time	0 to 10 s	0.1 s	0 s		237
	152	M462	Zero current detection level	0% to 400%	0.1%	5%		237
	153	M463	Zero current detection time	0 to 10 s	0.01 s	0.5 s		237
—	154	H631	Voltage reduction selection during stall prevention operation	1, 11	1	1		195
—	156	H501	Stall prevention operation selection	0 to 31, 100, 101	1	0		195
—	157	M430	OL signal output timer	0 to 25 s, 9999	0.1 s	0 s		87, 195

Function	Pr.	Pr. group	Name	Setting range	Minimum setting increments	Initial value ^{*1}		Refer to page	
						Gr.1	Gr.2		
—	158	M301	AM terminal function selection	1 to 3, 5 to 14, 17, 18, 21, 24, 32, 33, 37, 50, 52, 53, 61, 62, 67, 97, 98	1	1		216	
—	160	E440	User group read selection <i>Simple</i>	0, 1, 9999	1	0		117	
—	161	E200	Frequency setting/key lock operation selection	0, 1, 10, 11	1	0		104	
Automatic restart	162	A700	Automatic restart after instantaneous power failure selection	0, 1, 10, 11	1	0		307, 312, 314	
	165	A710	Stall prevention operation level for restart	0% to 400%	0.1%	150%		307	
Current detection	166	M433	Output current detection signal retention time	0 to 10 s, 9999	0.1 s	0.1 s		237	
	167	M464	Output current detection operation selection	0, 1, 10, 11	1	0		237	
—	168	E000	Parameter for manufacturer setting. Do not set.						
		E080							
—	169	E001							
		E081							
Cumulative monitor	170	M020	Watt-hour meter clear	0, 10, 9999	1	9999		208	
	171	M030	Operation hour meter clear	0, 9999	1	9999		208	
User group	172	E441	User group registered display/batch clear	9999, (0 to 16)	1	0		117	
	173	E442	User group registration	0 to 1999, 9999	1	9999		117	
	174	E443	User group clear	0 to 1999, 9999	1	9999		117	
Input terminal function assignment	178	T700	STF terminal function selection	0 to 5, 7, 8, 10, 12, 14, 16, 18, 23 to 25, 27, 30, 37, 46, 47, 60, 62, 64 to 67, 72, 84, 9999	1	60		252	
	179	T701	STR terminal function selection	0 to 5, 7, 8, 10, 12, 14, 16, 18, 23 to 25, 27, 30, 37, 46, 47, 61, 62, 64 to 67, 72, 84, 9999	1	61		252	
	180	T702	RL terminal function selection	0 to 5, 7, 8, 10, 12, 14, 16, 18, 23 to 25, 27, 30, 37, 46, 47, 62, 64 to 67, 72, 84, 9999	1	0		252	
	181	T703	RM terminal function selection		1	1		252	
	182	T704	RH terminal function selection		1	2		252	
	185	T751	NET X1 input selection	0 to 4, 8, 14, 18, 23, 24, 27, 30, 37, 46, 47, 64, 72, 84, 9999	1	9999		252	
	186	T752	NET X2 input selection		1			252	
	187	T753	NET X3 input selection		1			252	
	188	T754	NET X4 input selection		1			252	
189	T755	NET X5 input selection		1			252		

Function	Pr.	Pr. group	Name	Setting range	Minimum setting increments	Initial value ^{*1}		Refer to page
						Gr.1	Gr.2	
Output terminal function assignment	190	M400	RUN terminal function selection	0, 1, 3, 4, 7, 8, 11 to 16, 18, 19, 25, 26, 33, 34, 40, 41, 44 to 48, 57, 64 to 66, 70, 79 to 81, 90 to 93, 95, 96, 98, 99, 100, 101, 103, 104, 107, 108, 111 to 116, 125, 126, 133, 134, 140, 141, 144 to 148, 157, 164 to 166, 170, 179 to 181, 190 to 193, 195, 196, 198, 199, 206, 207, 211 to 213, 306, 307, 311 to 313, 9999	1	0		226
	191	M404	FU terminal function selection	0, 1, 3, 4, 7, 8, 11 to 16, 18, 19, 25, 26, 33, 34, 40, 41, 44 to 48, 57, 64 to 66, 70, 79 to 81, 90 to 93, 95, 96, 98, 99, 100, 101, 103, 104, 107, 108, 111 to 116, 125, 126, 133, 134, 140, 141, 144 to 148, 157, 164 to 166, 170, 179 to 181, 190 to 193, 195, 196, 198, 199, 206, 207, 211 to 213, 306, 307, 311 to 313, 9999	1	4		226
	192	M405	ABC terminal function selection	0, 1, 3, 4, 7, 8, 11 to 16, 18, 19, 25, 26, 33, 34, 40, 41, 44 to 48, 57, 64 to 66, 70, 79 to 81, 90, 91, 95, 96, 98, 99, 100, 101, 103, 104, 107, 108, 111 to 116, 125, 126, 133, 134, 140, 141, 144 to 148, 157, 164 to 166, 170, 179 to 181, 190, 191, 195, 196, 198, 199, 206, 207, 211 to 213, 306, 307, 311 to 313, 9999	1	99		226
	193	M451	NET Y1 output selection	0, 1, 3, 4, 7, 8, 11 to 16, 18, 19, 25, 26, 33, 34, 40, 41, 44 to 48, 57, 64 to 66, 70, 79 to 81, 90 to 93, 95, 98, 99, 100, 101, 103, 104, 107, 108, 111 to 116, 125, 126, 133, 134, 140, 141, 144 to 148, 157, 164 to 166, 170, 179 to 181, 190 to 193, 195, 198, 199, 206, 207, 211 to 213, 306, 307, 311 to 313, 9999	1	9999		226
	194	M452	NET Y2 output selection	0, 1, 3, 4, 7, 8, 11 to 16, 18, 19, 25, 26, 33, 34, 40, 41, 44 to 48, 57, 64 to 66, 70, 79 to 81, 90 to 93, 95, 98, 99, 100, 101, 103, 104, 107, 108, 111 to 116, 125, 126, 133, 134, 140, 141, 144 to 148, 157, 164 to 166, 170, 179 to 181, 190 to 193, 195, 198, 199, 206, 207, 211 to 213, 306, 307, 311 to 313, 9999	1	9999		226
	195	M453	NET Y3 output selection	0, 1, 3, 4, 7, 8, 11 to 16, 18, 19, 25, 26, 33, 34, 40, 41, 44 to 48, 57, 64 to 66, 70, 79 to 81, 90 to 93, 95, 98, 99, 100, 101, 103, 104, 107, 108, 111 to 116, 125, 126, 133, 134, 140, 141, 144 to 148, 157, 164 to 166, 170, 179 to 181, 190 to 193, 195, 198, 199, 206, 207, 211 to 213, 306, 307, 311 to 313, 9999	1	9999		226
196	M454	NET Y4 output selection	0, 1, 3, 4, 7, 8, 11 to 16, 18, 19, 25, 26, 33, 34, 40, 41, 44 to 48, 57, 64 to 66, 70, 79 to 81, 90 to 93, 95, 98, 99, 100, 101, 103, 104, 107, 108, 111 to 116, 125, 126, 133, 134, 140, 141, 144 to 148, 157, 164 to 166, 170, 179 to 181, 190 to 193, 195, 198, 199, 206, 207, 211 to 213, 306, 307, 311 to 313, 9999	1	9999		226	

◆ Pr.200 to Pr.299

Function	Pr.	Pr. group	Name	Setting range	Minimum setting increments	Initial value ^{*1}		Refer to page
						Gr.1	Gr.2	
Multi-speed setting	232 to 239	D308 to D315	Multi-speed setting (speed 8 to speed 15)	0 to 590 Hz, 9999	0.01 Hz	9999		163
—	240	E601	Soft-PWM operation selection	0, 1	1	1		120
—	241	M043	Analog input display unit switchover	0, 1	1	0		248
—	244	H100	Cooling fan operation selection	0, 1	1	1		174
Slip compensation	245	G203	Rated slip	0% to 50%, 9999	0.01%	9999		350
	246	G204	Slip compensation time constant	0.01 to 10 s	0.01 s	0.5 s		350
	247	G205	Constant output range slip compensation selection	0, 9999	1	9999		350
—	249	H101	Earth (ground) fault detection at start	0, 1	1	0	1	175
—	250	G106	Stop selection	0 to 100 s, 1000 to 1100 s, 8888, 9999	0.1 s	9999		258, 338
—	251	H200	Output phase loss protection selection	0, 1	1	1		178
Life check	255	E700	Life alarm status display	(0 to 367)	1	0		122
	256	E701	Inrush current limit circuit life display	(0% to 100%)	1%	100%		122
	257	E702	Control circuit capacitor life display	(0% to 100%)	1%	100%		122
	258	E703	Main circuit capacitor life display	(0% to 100%)	1%	100%		122
	259	E704	Main circuit capacitor life measuring	0, 1 (2, 3, 8, 9)	1	0		122
—	260	E602	PWM frequency automatic switchover	0, 10	1	10		120
Power failure stop	261	A730	Power failure stop selection	0 to 2	1	0		318
—	267	T001	Terminal 4 input selection	0 to 2	1	0		243
—	268	M022	Monitor decimal digits selection	0, 1, 9999	1	9999		208
—	269	E023	Parameter for manufacturer setting. Do not set.					
—	289	M431	Inverter output terminal filter	5 to 50 ms, 9999	1 ms	9999		226
—	291	D100	Pulse train input selection	0, 1	1	0		159
—	295	E201	Frequency change increment amount setting	0, 0.01, 0.1, 1, 10	0.01	0		106
Password	296	E410	Password lock level	1 to 6, 99, 101 to 106, 199, 9999	1	9999		111
	297	E411	Password lock/unlock	(0 to 5), 1000 to 9998, 9999	1	9999		111
—	298	A711	Frequency search gain	0 to 32767, 9999	1	9999		266, 314
—	299	A701	Rotation direction detection selection at restarting	0, 1, 9999	1	0		307

◆ Pr.300 to Pr.399

Function	Pr.	Pr. group	Name	Setting range	Minimum setting increments	Initial value*1		Refer to page
						Gr.1	Gr.2	
RS-485 communication	338	D010	Communication operation command source	0, 1	1	0		153
	339	D011	Communication speed command source	0 to 2	1	0		153
	340	D001	Communication startup mode selection	0, 1, 10	1	0		152
	342	N001	Communication EEPROM write selection	0, 1	1	0		*6
	343	N080	Communication error count	(0 to 999)	1	0		*6
—	374	H800	Overspeed detection level	0 to 400 Hz, 9999	0.01 Hz	9999		205
Pulse train input	384	D101	Input pulse division scaling factor	0 to 250	1	0		159
	385	D110	Frequency for zero input pulse	0 to 590 Hz	0.01 Hz	0 Hz		159
	386	D111	Frequency for maximum input pulse	0 to 590 Hz	0.01 Hz	60 Hz	50 Hz	159

◆ Pr.400 to Pr.499

Function	Pr.	Pr. group	Name	Setting range	Minimum setting increments	Initial value*1		Refer to page
						Gr.1	Gr.2	
Second motor constant	450	C200	Second applied motor	0, 10, 9999	1	9999		261
Remote output	495	M500	Remote output selection	0, 1, 10, 11	1	0		239
	496	M501	Remote output data 1	0 to 4095	1	0		239

◆ Pr.500 to Pr.599

Function	Pr.	Pr. group	Name	Setting range	Minimum setting increments	Initial value*1		Refer to page
						Gr.1	Gr.2	
—	502	N013	Stop mode selection at communication error	0 to 2, 6	1	0		*6
Maintenance	503	E710	Maintenance timer	0 (1 to 9998)	1	0		126
	504	E711	Maintenance timer warning output set time	0 to 9998, 9999	1	9999		126
—	505	M001	Speed setting reference	1 to 590 Hz	0.01 Hz	60 Hz	50 Hz	206
Life check	506	E705	Display estimated main circuit capacitor residual life	(0% to 100%)	1%	100%		122
	507	E706	Display/reset ABC relay contact life	(0% to 100%)	1%	100%		122
	509	E708	Display power cycle life	(0% to 100%)	0.01%	100%		122
Emergency drive	514	H324	Emergency drive dedicated retry waiting time	0.1 to 600 s, 9999	0.1 s	9999		182
	515	H322	Emergency drive dedicated retry count	1 to 200, 9999	1	1		182
	523	H320	Emergency drive mode selection	100, 111, 112, 121, 122, 200, 211, 212, 221, 222, 300, 311, 312, 321, 322, 400, 411, 412, 421, 422, 9999	1	9999		182
	524	H321	Emergency drive running speed	0 to 590 Hz, 9999	0.01 Hz	9999		182

Function	Pr.	Pr. group	Name	Setting range	Minimum setting increments	Initial value ^{*1}		Refer to page
						Gr.1	Gr.2	
Vibration suppression control	532	G225	Vibration suppression mode selection	1, 2, 9999	1	9999		352
	533	G226	Vibration suppression response adjustment	0% to 200%, 9999	1%	9999		352
	534	G227	Maximum vibration suppression frequency	0 to 400 Hz, 9999	0.01 Hz	9999		352
	535	G228	Minimum vibration suppression frequency	0 to 400 Hz, 9999	0.01 Hz	9999		352
USB	547	N040	USB communication station number	0 to 31	1	0		*6
	548	N041	USB communication check time interval	0 to 999.8 s, 9999	0.1 s	9999		*6
Communication	549	N000	Protocol selection	0, 1	1	0		*6
	551	D013	PU mode operation command source selection	2 to 4, 9999	1	9999		153
—	552	H429	Frequency jump range	0 to 30 Hz, 9999	0.01 Hz	9999		193
PID control	553	A603	PID deviation limit	0% to 100%, 9999	0.1%	9999		283
	554	A604	PID signal operation selection	0 to 3, 10 to 13	1	0		283
Average current monitoring	555	E720	Current average time	0.1 to 1 s	0.1 s	1 s		127
	556	E721	Data output mask time	0 to 20 s	0.1 s	0 s		127
	557	E722	Current average value monitor signal output reference current	0 to 500 A	0.01 A	Inverter rated current		127
—	561	H020	PTC thermistor protection level	0.5 to 30 kΩ, 9999	0.01 kΩ	9999		166
—	563	M021	Energization time carrying-over times	(0 to 65535)	1	0		208
—	564	M031	Operating time carrying-over times	(0 to 65535)	1	0		208
Multiple rating	570	E301	Multiple rating setting [3-phase]	0, 2	1	2		108
—	571	F103	Holding time at a start	0 to 10 s, 9999	0.1 s	9999		139
PID control	575	A621	Output interruption detection time	0 to 3600 s, 9999	0.1 s	1 s		283
	576	A622	Output interruption detection level	0 to 590 Hz	0.01 Hz	0 Hz		283
	577	A623	Output interruption cancel level	900% to 1100%	0.1%	1000%		283
Traverse	592	A300	Traverse function selection	0 to 2	1	0		281
	593	A301	Maximum amplitude amount	0% to 25%	0.1%	10%		281
	594	A302	Amplitude compensation amount during deceleration	0% to 50%	0.1%	10%		281
	595	A303	Amplitude compensation amount during acceleration	0% to 50%	0.1%	10%		281
	596	A304	Amplitude acceleration time	0.1 to 3600 s	0.1 s	5 s		281
	597	A305	Amplitude deceleration time	0.1 to 3600 s	0.1 s	5 s		281

◆ Pr.600 to Pr.699

Function	Pr.	Pr. group	Name	Setting range	Minimum setting increments	Initial value ^{*1}		Refer to page
						Gr.1	Gr.2	
Electronic thermal O/L relay	600	H001	First free thermal reduction frequency 1	0 to 590 Hz, 9999	0.01 Hz	9999		166
	601	H002	First free thermal reduction ratio 1	1% to 100%	1%	100%		166
	602	H003	First free thermal reduction frequency 2	0 to 590 Hz, 9999	0.01 Hz	9999		166
	603	H004	First free thermal reduction ratio 2	1% to 100%	1%	100%		166
	604	H005	First free thermal reduction frequency 3	0 to 590 Hz, 9999	0.01 Hz	9999		166
—	607	H006	Motor permissible load level	110% to 250%	1%	150%		166
—	608	H016	Second motor permissible load level	110% to 250%, 9999	1%	9999		166

Function	Pr.	Pr. group	Name	Setting range	Minimum setting increments	Initial value ^{*1}		Refer to page
						Gr.1	Gr.2	
PID control	609	A624	PID set point/deviation input selection	2, 3	1	2		283, 300
	610	A625	PID measured value input selection	2, 3	1	3		283, 300
—	611	F003	Acceleration time at a restart	0 to 3600 s, 9999	0.1 s	9999		307, 312
—	631	H182	Inverter output fault detection enable/disable selection	0, 1	1	0		176
—	643	E386	Voltage compensation amount setting	0% to 150%, 9999	1%	9999		93
Speed smoothing control	653	G410	Speed smoothing control	0% to 200%	0.1%	0%		351
	654	G411	Speed smoothing cutoff frequency	0 to 120 Hz	0.01 Hz	20 Hz		351
Increased magnetic excitation deceleration	660	G130	Increased magnetic excitation deceleration operation selection	0, 1	1	0		348
	661	G131	Magnetic excitation increase rate	0% to 40%, 9999	0.1%	9999		348
	662	G132	Increased magnetic excitation current level	0% to 200%	0.1%	100%		348
—	663	M060	Control circuit temperature signal output level	0 to 100°C	1°C	0°C		242
—	665	G125	Regeneration avoidance frequency gain	0% to 200%	0.1%	100%		345
—	673	G060	SF-PR slip amount adjustment operation selection	2, 4, 6, 9999	1	9999		334
—	674	G061	SF-PR slip amount adjustment gain	0% to 500%	0.1%	100%		334
Electronic thermal O/L relay	692	H011	Second free thermal reduction frequency 1	0 to 590 Hz, 9999	0.01 Hz	9999		166
	693	H012	Second free thermal reduction ratio 1	1% to 100%	1%	100%		166
	694	H013	Second free thermal reduction frequency 2	0 to 590 Hz, 9999	0.01 Hz	9999		166
	695	H014	Second free thermal reduction ratio 2	1% to 100%	1%	100%		166
	696	H015	Second free thermal reduction frequency 3	0 to 590 Hz, 9999	0.01 Hz	9999		166
—	699	T740	Input terminal filter	5 to 50 ms, 9999	1 ms	9999		252

◆ Pr.700 to Pr.799

Function	Pr.	Pr. group	Name	Setting range	Minimum setting increments	Initial value ^{*1}		Refer to page
						Gr.1	Gr.2	
Motor constant	702	C106	Maximum motor frequency	0 to 400 Hz, 9999	0.01 Hz	9999		274
	706	C130	Motor induced voltage constant (phi f)	0 to 5000 mV (rad/s), 9999	0.1 mV (rad/s)	9999		274
	707	C107	Motor inertia (integer)	10 to 999, 9999	1	9999		274, 352
	711	C131	Motor Ld decay ratio	0% to 100%, 9999	0.1%	9999		274
	712	C132	Motor Lq decay ratio	0% to 100%, 9999	0.1%	9999		274
	717	C182	Starting resistance tuning compensation coefficient	0% to 200%, 9999	0.1%	9999		274
	721	C185	Starting magnetic pole position detection pulse width	0 to 6000 μs, 9999	1 μs	9999		274
	724	C108	Motor inertia (exponent)	0 to 7, 9999	1	9999		274, 352
	725	C133	Motor protection current level	100% to 500%, 9999	0.1%	9999		274
—	759	A600	PID unit selection	0 to 43, 9999	1	9999		297

Function	Pr.	Pr. group	Name	Setting range	Minimum setting increments	Initial value ^{*1}		Refer to page
						Gr.1	Gr.2	
Monitoring	774	M101	Operation panel monitor selection 1	1 to 3, 5 to 14, 17, 18, 20, 23 to 25, 32,	1	9999		208
	775	M102	Operation panel monitor selection 2	33, 37, 38, 44, 50 to 55, 61, 62, 64, 67, 68, 91, 97, 98, 100, 9999	1	9999		208
	776	M103	Operation panel monitor selection 3		1	9999		208
—	779	N014	Operation frequency during communication error	0 to 590 Hz, 9999	0.01 Hz	9999		*6
—	791	F070	Acceleration time in low-speed range	0 to 3600 s, 9999	0.1 s	9999		130
—	792	F071	Deceleration time in low-speed range	0 to 3600 s, 9999	0.1 s	9999		130
—	795	G111	DC injection brake operation current level	0% to 200%, 9999	0.1%	9999		335
—	799	M520	Pulse increment setting for output power	0.1, 1, 10, 100, 1000 kWh	0.1 kWh	1 kWh		241

◆ Pr.800 to Pr.999

Function	Pr.	Pr. group	Name	Setting range	Minimum setting increments	Initial value ^{*1}		Refer to page
						Gr.1	Gr.2	
—	800	G200	Control method selection	10, 19, 20, 40	1	40		72
Torque limit	810	H700	Torque limit input method selection	0	1	0		87
	811	D030	Set resolution switchover	0, 10	1	0		87
	815	H710	Torque limit level 2	0% to 400%, 9999	0.1%	9999		87
Adjustment	820	G211	Speed control P gain	0% to 1000%	1%	25%		90
	821	G212	Speed control integral time	0 to 20 s	0.001 s	0.333 s		90
	824	G213	Torque control P gain (current loop proportional gain)	0% to 500%	1%	50%		90
	825	G214	Torque control integral time (current loop integral time)	0 to 500 ms	0.1 ms	20 ms		90
Additional function	859	C126	Torque current/Rated PM motor current	0 to 500 A, 9999	0.01 A	9999		266, 274
	865	M446	Low speed detection	0 to 590 Hz	0.01 Hz	1.5 Hz		234
Indication	866	M042	Torque monitoring reference	0% to 400%	0.1%	150%		216
—	870	M440	Speed detection hysteresis	0 to 15 Hz	0.01 Hz	0 Hz		234
Protective function	872	H201	Input phase loss protection selection [3-phase]	0, 1	1	1		178
	874	H730	OLT level setting	0% to 400%	0.1%	150%		87
Regeneration avoidance	882	G120	Regeneration avoidance operation selection	0 to 2	1	0		345
	883	G121	Regeneration avoidance operation level	300 to 800 V	0.1 V	[100/200 V class] 400 V [400 V class] 780 V		345
	885	G123	Regeneration avoidance compensation frequency limit value	0 to 45 Hz, 9999	0.01 Hz	6 Hz		345
	886	G124	Regeneration avoidance voltage gain	0% to 200%	0.1%	100%		345
Free parameter	888	E420	Free parameter 1	0 to 9999	1	9999		114
	889	E421	Free parameter 2	0 to 9999	1	9999		114
—	890	H325	Internal storage device status indication	(0 to 255)	1	0		190

Function	Pr.	Pr. group	Name	Setting range	Minimum setting increments	Initial value ^{*1}		Refer to page
						Gr.1	Gr.2	
Energy saving monitoring	891	M023	Cumulative power monitor digit shifted times	0 to 4, 9999	1	9999		208, 219
	892	M200	Load factor	30% to 150%	0.1%	100%		219
	893	M201	Energy saving monitor reference (motor capacity)	0.1 to 18.5 kW	0.01 kW	Applicable motor capacity		219
	894	M202	Control selection during commercial power-supply operation	0 to 3	1	0		219
	895	M203	Power saving rate reference value	0, 1, 9999	1	9999		219
	896	M204	Power unit cost / CO ₂ emission coefficient	0 to 500, 9999	0.01	9999		219
	897	M205	Energy saving monitor average time	0 to 1000 h, 9999	1 h	9999		219
	898	M206	Energy saving cumulative monitor clear	0, 1, 10, 9999	1	9999		219
	899	M207	Operation time rate (estimated value)	0% to 100%, 9999	0.1%	9999		219
PU	990	E104	PU buzzer control	0, 1	1	1		101
	991	E105	PU contrast adjustment	0 to 63	1	58		102
Monitoring	992	M104	Operation panel setting dial push monitor selection	0 to 3, 5 to 14, 17, 18, 20, 23 to 25, 32, 33, 37, 38, 44, 50 to 55, 61, 62, 64, 67, 68, 91, 97, 98, 100	1	0		208
—	997	H103	Fault initiation	0 to 255, 9999	1	9999		177
—	998	E430	PM parameter initialization <i>Simple</i>	0, 3044, 3144, 8009, 8109, 9009, 9109	1	0		77
—	999	E431	Automatic parameter setting <i>Simple</i>	10, 12, 20, 21, 9999	1	9999		115

◆ Pr.1000 to Pr.1099

Function	Pr.	Pr. group	Name	Setting range	Minimum setting increments	Initial value ^{*1}		Refer to page
						Gr.1	Gr.2	
—	1002	C150	Lq tuning target current adjustment coefficient	50% to 150%, 9999	0.1%	9999		274
Clock	1006	E020	Clock (year)	2000 to 2099	1	2000		96
	1007	E021	Clock (month, day)	Jan. 1 to Dec. 31	1	101		96
	1008	E022	Clock (hour, minute)	0:00 to 23:59	1	0		96
—	1013	H323	Running speed after recovery from emergency drive undervoltage	0 to 590 Hz	0.01 Hz	60 Hz	50 Hz	182
—	1015	A607	Integral stop selection at limited frequency	0 to 2, 10 to 12	1	10		283
—	1016	H021	PTC thermistor protection detection time	0 to 60 s	1 s	0 s		166

Function	Pr.	Pr. group	Name	Setting range	Minimum setting increments	Initial value ^{*1}		Refer to page
						Gr.1	Gr.2	
Trace	1020	A900	Trace operation selection	0 to 3	1	0		320
	1022	A902	Sampling cycle	1, 2, 5, 10, 50, 100, 500, 1000	1	1		320
	1023	A903	Number of analog channels	1 to 8	1	4		320
	1024	A904	Sampling auto start	0, 1	1	0		320
	1025	A905	Trigger mode selection	0 to 4	1	0		320
	1026	A906	Number of sampling before trigger	0% to 100%	1%	90%		320
	1027	A910	Analog source selection (1ch)	1 to 3, 5 to 14, 17, 18, 20, 23, 24, 32, 33, 37, 52 to 54, 61, 62, 64, 67, 68, 91, 97, 98, 201 to 210, 212, 213, 230 to 232, 235 to 238	1	201		320
	1028	A911	Analog source selection (2ch)			202		320
	1029	A912	Analog source selection (3ch)			203		320
	1030	A913	Analog source selection (4ch)			204		320
	1031	A914	Analog source selection (5ch)			205		320
	1032	A915	Analog source selection (6ch)			206		320
	1033	A916	Analog source selection (7ch)			207		320
	1034	A917	Analog source selection (8ch)			208		320
	1035	A918	Analog trigger channel	1 to 8	1	1		320
	1036	A919	Analog trigger operation selection	0, 1	1	0		320
	1037	A920	Analog trigger level	600 to 1400	1	1000		320
	1038	A930	Digital source selection (1ch)	0 to 255	1	0		320
	1039	A931	Digital source selection (2ch)			0		320
	1040	A932	Digital source selection (3ch)			0		320
	1041	A933	Digital source selection (4ch)			0		320
	1042	A934	Digital source selection (5ch)			0		320
	1043	A935	Digital source selection (6ch)			0		320
1044	A936	Digital source selection (7ch)	0			320		
1045	A937	Digital source selection (8ch)	0			320		
1046	A938	Digital trigger channel	1 to 8	1	1		320	
1047	A939	Digital trigger operation selection	0, 1	1	0		320	
—	1048	E106	Display-off waiting time	0 to 60, 100 to 160 min	1 min	0 min		103

◆ Pr.1100 to Pr.1399

Function	Pr.	Pr. group	Name	Setting range	Minimum setting increments	Initial value ^{*1}		Refer to page
						Gr.1	Gr.2	
Monitoring	1106	M050	Torque monitor filter	0 to 5 s, 9999	0.01 s	9999		208
	1107	M051	Running speed monitor filter	0 to 5 s, 9999	0.01 s	9999		208
	1108	M052	Excitation current monitor filter	0 to 5 s, 9999	0.01 s	9999		208
—	1200	M390	AM output offset calibration	4000 to 5000	1	4499		218

◆ Pr.1400 to Pr.1499

Function	Pr.	Pr. group	Name	Setting range	Minimum setting increments	Initial value ^{*1}		Refer to page
						Gr.1	Gr.2	
—	1412	C135	Motor induced voltage constant (phi f) exponent	0 to 2, 9999	1	9999		274

Function	Pr.	Pr. group	Name	Setting range	Minimum setting increments	Initial value*1		Refer to page
						Gr.1	Gr.2	
Load characteristics fault detection	1480	H520	Load characteristics measurement mode	0, 1 (2 to 5, 81 to 85)	1	0		200
	1481	H521	Load characteristics load reference 1	0% to 400%, 8888, 9999	0.1%	9999		200
	1482	H522	Load characteristics load reference 2	0% to 400%, 8888, 9999	0.1%	9999		200
	1483	H523	Load characteristics load reference 3	0% to 400%, 8888, 9999	0.1%	9999		200
	1484	H524	Load characteristics load reference 4	0% to 400%, 8888, 9999	0.1%	9999		200
	1485	H525	Load characteristics load reference 5	0% to 400%, 8888, 9999	0.1%	9999		200
	1486	H526	Load characteristics maximum frequency	0 to 590 Hz	0.01 Hz	60 Hz	50 Hz	200
	1487	H527	Load characteristics minimum frequency	0 to 590 Hz	0.01 Hz	6 Hz		200
	1488	H531	Upper limit warning detection width	0% to 400%, 9999	0.1%	20%		200
	1489	H532	Lower limit warning detection width	0% to 400%, 9999	0.1%	20%		200
	1490	H533	Upper limit fault detection width	0% to 400%, 9999	0.1%	9999		200
	1491	H534	Lower limit fault detection width	0% to 400%, 9999	0.1%	9999		200
	1492	H535	Load status detection signal delay time / load reference measurement waiting time	0 to 60 s	0.1 s	1 s		200
—	1499	E415	Parameter for manufacturer setting. Do not set.					

◆ Alphabet (calibration parameters, etc.)

Function	Pr.	Pr. group	Name	Setting range	Minimum setting increments	Initial value*1		Refer to page
						Gr.1	Gr.2	
Calibration parameter	C1 (901) ^{*5}	M320	AM terminal calibration	—	—	—		218
	C2 (902) ^{*5}	T200	Terminal 2 frequency setting bias frequency	0 to 590 Hz	0.01 Hz	0 Hz		248
	C3 (902) ^{*5}	T201	Terminal 2 frequency setting bias	0% to 300%	0.1%	0%		248
	125 (903) ^{*5}	T202	Terminal 2 frequency setting gain frequency	0 to 590 Hz	0.01 Hz	60 Hz	50 Hz	248
	C4 (903) ^{*5}	T203	Terminal 2 frequency setting gain	0% to 300%	0.1%	100%		248
	C5 (904) ^{*5}	T400	Terminal 4 frequency setting bias frequency	0 to 590 Hz	0.01 Hz	0 Hz		248
	C6 (904) ^{*5}	T401	Terminal 4 frequency setting bias	0% to 300%	0.1%	20%		248
	126 (905) ^{*5}	T402	Terminal 4 frequency setting gain frequency	0 to 590 Hz	0.01 Hz	60 Hz	50 Hz	248
	C7 (905) ^{*5}	T403	Terminal 4 frequency setting gain	0% to 300%	0.1%	100%		248
PID display	C42 (934) ^{*5}	A630	PID display bias coefficient	0 to 500, 9999	0.01	9999		297
	C43 (934) ^{*5}	A631	PID display bias analog value	0% to 300%	0.1%	20%		297
	C44 (935) ^{*5}	A632	PID display gain coefficient	0 to 500, 9999	0.01	9999		297
	C45 (935) ^{*5}	A633	PID display gain analog value	0% to 300%	0.1%	100%		297

Function	Pr.	Pr. group	Name	Setting range	Minimum setting increments	Initial value ^{*1}		Refer to page
						Gr.1	Gr.2	
Clear parameters	PR.CL		Parameter clear	(0), 1	1	0		353
	ALLC		All parameter clear	(0), 1	1	0		353
	ER.CL		Fault history clear	(0), 1	1	0		355
—	PR.CH		Initial value change list	—	1	0		46
—	PM		PM parameter initialization	0	1	0		77
—	AUTO		Automatic parameter setting	—	—	—		115
—	PR.GR		Parameter initial value group setting	1, 2	1	1	2	356
—	PR.MD		Group parameter setting	(0), 1, 2	1	0		63

*1 Gr.1 and Gr.2 are the parameter initial value groups. (Refer to [page 46](#).)

*2 Differs depending on the capacity.

6%: FR-D820-0.75K-042 or lower, FR-D840-0.75K-022 or lower, FR-D820S-0.75K-042 or lower, and FR-D810W-0.75K-042 or lower

4%: FR-D820-1.5K-070 to FR-D820-3.7K-165, FR-D840-1.5K-037 to FR-D840-3.7K-081, and FR-D820S-1.5K-070 or higher

3%: FR-D820-5.5K-238, FR-D820-7.5K-318, FR-D840-5.5K-120, and FR-D840-7.5K-163

2%: FR-D820-11K-450 or higher, FR-D840-11K-230 or higher

*3 Differs depending on the capacity.

5 s: FR-D820-3.7K-165 or lower, FR-D840-3.7K-081 or lower, FR-D820S-2.2K-100 or lower, and FR-D810W-0.75K-042 or lower

10 s: FR-D820-5.5K-238, FR-D820-7.5K-318, FR-D840-5.5K-120, and FR-D840-7.5K-163

15 s: FR-D820-11K-450 or higher, FR-D840-11K-230 or higher

*4 Differs depending on the capacity.

6%: FR-D820-0.2K-014 or lower, FR-D820S-0.2K-014 or lower, and FR-D810W-0.2K-014 or lower

4%: FR-D820-0.4K-025 to FR-D820-7.5K-318, FR-D840-0.4K-012 to FR-D840-7.5K-163, FR-D820S-0.4K-025 or higher, and FR-D810W-0.4K-025 or higher

2%: FR-D820-11K-450 or higher, FR-D840-11K-230 or higher

*5 On the LCD operation panel or the parameter unit used as the command source, the parameter number in parentheses appears instead of that starting with the letter C.

*6 For details, refer to the Instruction Manual (Communication).

3.3 Use of a function group number for the identification of parameters

A parameter identification number shown on the PU can be switched from a parameter number to a function group number. As parameters are grouped by function and displayed by the group, the related parameters can be set continually at a time.

◆ Changing a parameter identification number to a function group number

Pr.MD setting	Description
0	The setting of parameter identification number remains the same as the last setting.
1	The parameter number is used for the identification of parameters, and displayed in numerical order.
2	The function group number is used for the identification of parameters, and displayed in alphanumeric order.

Operating procedure

1. Turning ON the power of the inverter
The operation panel is in the monitor mode.
2. Selecting the parameter setting mode
Press the MODE key to choose the parameter setting mode. (The parameter number read previously appears on the display.)
3. Selecting a parameter
Turn the setting dial until "Pr.MD" (Group parameter setting) appears.
Press the SET key to confirm the selection. "0 (initial value)" will appear.
4. Selecting the use of the function group number
Turn the setting dial to change the value to "2" (function group number). Press the SET key to confirm the Group parameter setting. "2" blinks after the setting is completed.

◆ Selecting a parameter by function group number to change its setting

The following shows the procedure to change the setting of P.H400 (Pr.1) Maximum frequency.

Operating procedure

1. Turning ON the power of the inverter
The operation panel is in the monitor mode.
2. Changing the operation mode
Press the HAND/AUTO key to choose the PU operation mode. [HAND] indicator turns ON.
3. Selecting the parameter setting mode
Press the MODE key to choose the parameter setting mode. (The parameter group number read previously appears.)
4. Enabling the function group selection
Turn the setting dial until "H4.." (Protective function parameter 4) appears. Press the SET key to confirm the selection. "H4--" will appear, which shows that the operation panel is ready for selection of a number in the group of monitor parameter 4.
5. Selecting a parameter
Turn the setting dial until "H400" (**P.H400 Maximum frequency**) appears. Press the SET key to display the present set value. "120.0 (initial value)" appears.
6. Changing the setting value
Turn the setting dial to change the value to "60.00". Press the SET key to confirm the setting. "60.00" blinks after the setting is completed.

3.4 Parameter list (by function group number)

◆ E: Environment setting parameters

Parameters for the inverter operating environment.

Pr. group	Pr.	Name	Refer to page
E000	168	Parameter for manufacturer setting. Do not set.	
E001	169	Parameter for manufacturer setting. Do not set.	
E020	1006	Clock (year)	96
E021	1007	Clock (month, day)	96
E022	1008	Clock (hour, minute)	96
E023	269	Parameter for manufacturer setting. Do not set.	
E080	168	Parameter for manufacturer setting. Do not set.	
E081	169	Parameter for manufacturer setting. Do not set.	
E100	75	Reset selection	97
E101		Disconnected PU detection	
E102		PU stop selection	
E103	145	PU display language selection	100
E104	990	PU buzzer control	101
E105	991	PU contrast adjustment	102
E106	1048	Display-off waiting time	103
E200	161	Frequency setting/key lock operation selection	104
E201	295	Frequency change increment amount setting	106
E202	40	RUN key rotation direction selection	107
E300	30	Regenerative function selection	340
E301	570	Multiple rating setting	108
E386	643	Voltage compensation amount setting	93
E400	77	Parameter write selection	109
E410	296	Password lock level	111
E411	297	Password lock/unlock	111
E415	1499	Parameter for manufacturer setting. Do not set.	
E420	888	Free parameter 1	114
E421	889	Free parameter 2	114
E430	998	PM parameter initialization <i>Simple</i>	77
E431	999	Automatic parameter setting <i>Simple</i>	115
E440	160	User group read selection <i>Simple</i>	117
E441	172	User group registered display/batch clear	117
E442	173	User group registration	117
E443	174	User group clear	117
E600	72	PWM frequency selection	120
E601	240	Soft-PWM operation selection	120

Pr. group	Pr.	Name	Refer to page
E602	260	PWM frequency automatic switchover	120
E700	255	Life alarm status display	122
E701	256	Inrush current limit circuit life display	122
E702	257	Control circuit capacitor life display	122
E703	258	Main circuit capacitor life display	122
E704	259	Main circuit capacitor life measuring	122
E705	506	Display estimated main circuit capacitor residual life	122
E706	507	Display/reset ABC relay contact life	122
E708	509	Display power cycle life	122
E710	503	Maintenance timer	126
E711	504	Maintenance timer warning output set time	126
E720	555	Current average time	127
E721	556	Data output mask time	127
E722	557	Current average value monitor signal output reference current	127

◆ F: Settings for acceleration/ deceleration

Parameters for the motor acceleration/deceleration characteristics.

Pr. group	Pr.	Name	Refer to page
F000	20	Acceleration/deceleration reference frequency	130
F002	16	Jog acceleration/ deceleration time	161
F003	611	Acceleration time at a restart	307, 312
F010	7	Acceleration time <i>Simple</i>	130
F011	8	Deceleration time <i>Simple</i>	130
F020	44	Second acceleration/ deceleration time	130, 300
F021	45	Second deceleration time	130, 300
F070	791	Acceleration time in low-speed range	130
F071	792	Deceleration time in low-speed range	130
F100	29	Acceleration/deceleration pattern selection	133
F101	59	Remote function selection	135
F102	13	Starting frequency	139, 141
F103	571	Holding time at a start	139

◆ D: Parameters for the setting of operation command and frequency command

Parameters for setting the command source to the inverter, and the motor driving frequency and torque.

Pr. group	Pr.	Name	Refer to page
D000	79	Operation mode selection <i>Simple</i>	142, 152
D001	340	Communication startup mode selection	152
D010	338	Communication operation command source	153
D011	339	Communication speed command source	153
D013	551	PU mode operation command source selection	153
D020	78	Reverse rotation prevention selection	158
D030	811	Set resolution switchover	87, 206
D100	291	Pulse train input selection	159
D101	384	Input pulse division scaling factor	159
D110	385	Frequency for zero input pulse	159
D111	386	Frequency for maximum input pulse	159
D200	15	Jog frequency	161
D301	4	Multi-speed setting (high speed) <i>Simple</i>	163
D302	5	Multi-speed setting (middle speed) <i>Simple</i>	163
D303	6	Multi-speed setting (low speed) <i>Simple</i>	163
D304 to D307	24 to 27	Multi-speed setting (speed 4 to speed 7)	163
D308 to D315	232 to 239	Multi-speed setting (speed 8 to speed 15)	163

◆ H: Protective function parameter

Parameters to protect the motor and the inverter.

Pr. group	Pr.	Name	Refer to page
H000	9	Electronic thermal O/L relay <i>Simple</i>	166, 266, 274
H001	600	First free thermal reduction frequency 1	166
H002	601	First free thermal reduction ratio 1	166
H003	602	First free thermal reduction frequency 2	166
H004	603	First free thermal reduction ratio 2	166
H005	604	First free thermal reduction frequency 3	166
H006	607	Motor permissible load level	166
H010	51	Second electronic thermal O/L relay	166

Pr. group	Pr.	Name	Refer to page
H011	692	Second free thermal reduction frequency 1	166
H012	693	Second free thermal reduction ratio 1	166
H013	694	Second free thermal reduction frequency 2	166
H014	695	Second free thermal reduction ratio 2	166
H015	696	Second free thermal reduction frequency 3	166
H016	608	Second motor permissible load level	166
H020	561	PTC thermistor protection level	166
H021	1016	PTC thermistor protection detection time	166
H100	244	Cooling fan operation selection	174
H101	249	Earth (ground) fault detection at start	175
H182	631	Inverter output fault detection enable/disable selection	176
H200	251	Output phase loss protection selection	178
H300	65	Retry selection	179
H301	67	Number of retries at fault occurrence	179
H302	68	Retry waiting time	179
H303	69	Retry count display erase	179
H320	523	Emergency drive mode selection	182
H321	524	Emergency drive running speed	182
H322	515	Emergency drive dedicated retry count	182
H323	1013	Running speed after recovery from emergency drive undervoltage	182
H324	514	Emergency drive dedicated retry waiting time	182
H325	890	Internal storage device status indication	190
H400	1	Maximum frequency <i>Simple</i>	191
H401	2	Minimum frequency <i>Simple</i>	191
H402	18	High speed maximum frequency	191
H420	31	Frequency jump 1A	193
H421	32	Frequency jump 1B	193
H422	33	Frequency jump 2A	193
H423	34	Frequency jump 2B	193
H424	35	Frequency jump 3A	193
H425	36	Frequency jump 3B	193
H429	552	Frequency jump range	193
H500	22	Stall prevention operation level (Torque limit level)	87, 195
H501	156	Stall prevention operation selection	195
H600	48	Second stall prevention operation level	195

Pr. group	Pr.	Name	Refer to page
H610	23	Stall prevention operation level compensation factor at double speed	195
H611	66	Stall prevention operation reduction starting frequency	195
H631	154	Voltage reduction selection during stall prevention operation	195
H103	997	Fault initiation	177
H800	374	Overspeed detection level	205
H520	1480	Load characteristics measurement mode	200
H521	1481	Load characteristics load reference 1	200
H522	1482	Load characteristics load reference 2	200
H523	1483	Load characteristics load reference 3	200
H524	1484	Load characteristics load reference 4	200
H525	1485	Load characteristics load reference 5	200
H526	1486	Load characteristics maximum frequency	200
H527	1487	Load characteristics minimum frequency	200
H531	1488	Upper limit warning detection width	200
H532	1489	Lower limit warning detection width	200
H533	1490	Upper limit fault detection width	200
H534	1491	Lower limit fault detection width	200
H535	1492	Load status detection signal delay time / load reference measurement waiting time	200
H700	810	Torque limit input method selection	87
H710	815	Torque limit level 2	87
H730	874	OLT level setting	87

◆ M: Item and output signal for monitoring

Parameters for the settings regarding the monitoring to check the inverter's operating status and the output signals for the monitoring.

Pr. group	Pr.	Name	Refer to page
M000	37	Speed display	206
M001	505	Speed setting reference	206
M003	53	Frequency / rotation speed unit switchover	206
M020	170	Watt-hour meter clear	208
M021	563	Energization time carrying-over times	208
M022	268	Monitor decimal digits selection	208
M023	891	Cumulative power monitor digit shifted times	208, 219
M030	171	Operation hour meter clear	208

Pr. group	Pr.	Name	Refer to page
M031	564	Operating time carrying-over times	208
M040	55	Frequency monitoring reference	216
M041	56	Current monitoring reference	216
M042	866	Torque monitoring reference	216
M043	241	Analog input display unit switchover	248
M050	1106	Torque monitor filter	208
M051	1107	Running speed monitor filter	208
M052	1108	Excitation current monitor filter	208
M060	663	Control circuit temperature signal output level	242
M100	52	Operation panel main monitor selection	208
M101	774	Operation panel monitor selection 1	208
M102	775	Operation panel monitor selection 2	208
M103	776	Operation panel monitor selection 3	208
M104	992	Operation panel setting dial push monitor selection	208
M200	892	Load factor	219
M201	893	Energy saving monitor reference (motor capacity)	219
M202	894	Control selection during commercial power-supply operation	219
M203	895	Power saving rate reference value	219
M204	896	Power unit cost / CO ₂ emission coefficient	219
M205	897	Energy saving monitor average time	219
M206	898	Energy saving cumulative monitor clear	219
M207	899	Operation time rate (estimated value)	219
M301	158	AM terminal function selection	216
M320	C1 (901) ^{*1}	AM terminal calibration	218
M390	1200	AM output offset calibration	218
M400	190	RUN terminal function selection	226
M404	191	FU terminal function selection	226
M405	192	ABC terminal function selection	226
M430	157	OL signal output timer	87, 195
M431	289	Inverter output terminal filter	226
M433	166	Output current detection signal retention time	237
M440	870	Speed detection hysteresis	234
M441	41	Up-to-frequency sensitivity	234
M442	42	Output frequency detection	234
M443	43	Output frequency detection for reverse rotation	234
M446	865	Low speed detection	234

Pr. group	Pr.	Name	Refer to page
M451	193	NET Y1 output selection	226
M452	194	NET Y2 output selection	226
M453	195	NET Y3 output selection	226
M454	196	NET Y4 output selection	226
M460	150	Output current detection level	237
M461	151	Output current detection signal delay time	237
M462	152	Zero current detection level	237
M463	153	Zero current detection time	237
M464	167	Output current detection operation selection	237
M500	495	Remote output selection	239
M501	496	Remote output data 1	239
M520	799	Pulse increment setting for output power	241

◆ T: Multi-function input terminal parameters

Parameters for the setting of the input terminals via which commands are given to the inverter.

Pr. group	Pr.	Name	Refer to page
T000	73	Analog input selection	243
T001	267	Terminal 4 input selection	243
T002	74	Input filter time constant	247
T022	125	Terminal 2 frequency setting gain frequency <i>Simple</i>	248
T042	126	Terminal 4 frequency setting gain frequency <i>Simple</i>	248
T200	C2 (902) ^{*1}	Terminal 2 frequency setting bias frequency	248
T201	C3 (902) ^{*1}	Terminal 2 frequency setting bias	248
T202	125 (903) ^{*1}	Terminal 2 frequency setting gain frequency	248
T203	C4 (903) ^{*1}	Terminal 2 frequency setting gain	248
T400	C5 (904) ^{*1}	Terminal 4 frequency setting bias frequency	248
T401	C6 (904) ^{*1}	Terminal 4 frequency setting bias	248
T402	126 (905) ^{*1}	Terminal 4 frequency setting gain frequency	248
T403	C7 (905) ^{*1}	Terminal 4 frequency setting gain	248
T700	178	STF terminal function selection	252
T701	179	STR terminal function selection	252
T702	180	RL terminal function selection	252
T703	181	RM terminal function selection	252
T704	182	RH terminal function selection	252
T720	17	MRS/X10 terminal input selection	255
T740	699	Input terminal filter	252

Pr. group	Pr.	Name	Refer to page
T751	185	NET X1 input selection	252
T752	186	NET X2 input selection	252
T753	187	NET X3 input selection	252
T754	188	NET X4 input selection	252
T755	189	NET X5 input selection	252

◆ C: Motor constant parameters

Parameters for the applied motor setting.

Pr. group	Pr.	Name	Refer to page
C100	71	Applied motor	261, 266, 274
C101	80	Motor capacity	72, 266, 274
C102	81	Number of motor poles	72, 266, 274
C103	9	Rated motor current <i>Simple</i>	166, 266, 274
C104	83	Rated motor voltage	72, 266, 274
C105	84	Rated motor frequency	72, 266, 274
C106	702	Maximum motor frequency	274
C107	707	Motor inertia (integer)	274, 352
C108	724	Motor inertia (exponent)	274, 352
C110	96	Auto tuning setting/status	266, 274, 314
C120	90	Motor constant (R1)	266, 274, 314
C121	91	Motor constant (R2)	266
C122	92	Motor constant (L1)/d-axis inductance (Ld)	266, 274
C123	93	Motor constant (L2)/q-axis inductance (Lq)	266, 274
C124	94	Motor constant (X)	266
C125	82	Motor excitation current	266
C126	859	Torque current/Rated PM motor current	266, 274
C130	706	Motor induced voltage constant (phi f)	274
C131	711	Motor Ld decay ratio	274
C132	712	Motor Lq decay ratio	274
C133	725	Motor protection current level	274
C135	1412	Motor induced voltage constant (phi f) exponent	274
C150	1002	Lq tuning target current adjustment coefficient	274
C182	717	Starting resistance tuning compensation coefficient	274
C185	721	Starting magnetic pole position detection pulse width	274
C200	450	Second applied motor	261
C203	51	Rated second motor current	166

◆ A: Application parameters

Parameters for the setting of a specific application.

Pr. group	Pr.	Name	Refer to page
A001	136	MC switchover interlock time	182
A004	139	Automatic switchover frequency from inverter to bypass operation	182
A300	592	Traverse function selection	281
A301	593	Maximum amplitude amount	281
A302	594	Amplitude compensation amount during deceleration	281
A303	595	Amplitude compensation amount during acceleration	281
A304	596	Amplitude acceleration time	281
A305	597	Amplitude deceleration time	281
A600	759	PID unit selection	297
A601	131	PID upper limit	283, 300
A602	132	PID lower limit	283, 300
A603	553	PID deviation limit	283
A604	554	PID signal operation selection	283
A607	1015	Integral stop selection at limited frequency	283
A610	128	PID action selection	283, 300
A611	133	PID action set point	283, 300
A612	127	PID control automatic switchover frequency	283
A613	129	PID proportional band	283, 300
A614	130	PID integral time	283, 300
A615	134	PID differential time	283, 300
A621	575	Output interruption detection time	283
A622	576	Output interruption detection level	283
A623	577	Output interruption cancel level	283
A624	609	PID set point/deviation input selection	283, 300
A625	610	PID measured value input selection	283, 300
A630	C42 (934) ^{*1}	PID display bias coefficient	297
A631	C43 (934) ^{*1}	PID display bias analog value	297
A632	C44 (935) ^{*1}	PID display gain coefficient	297
A633	C45 (935) ^{*1}	PID display gain analog value	297
A700	162	Automatic restart after instantaneous power failure selection	307, 312, 314
A701	299	Rotation direction detection selection at restarting	307
A702	57	Restart coasting time	307, 312
A703	58	Restart cushion time	307
A710	165	Stall prevention operation level for restart	307
A711	298	Frequency search gain	266, 314
A730	261	Power failure stop selection	318
A900	1020	Trace operation selection	320

Pr. group	Pr.	Name	Refer to page
A902	1022	Sampling cycle	320
A903	1023	Number of analog channels	320
A904	1024	Sampling auto start	320
A905	1025	Trigger mode selection	320
A906	1026	Number of sampling before trigger	320
A910	1027	Analog source selection (1ch)	320
A911	1028	Analog source selection (2ch)	320
A912	1029	Analog source selection (3ch)	320
A913	1030	Analog source selection (4ch)	320
A914	1031	Analog source selection (5ch)	320
A915	1032	Analog source selection (6ch)	320
A916	1033	Analog source selection (7ch)	320
A917	1034	Analog source selection (8ch)	320
A918	1035	Analog trigger channel	320
A919	1036	Analog trigger operation selection	320
A920	1037	Analog trigger level	320
A930	1038	Digital source selection (1ch)	320
A931	1039	Digital source selection (2ch)	320
A932	1040	Digital source selection (3ch)	320
A933	1041	Digital source selection (4ch)	320
A934	1042	Digital source selection (5ch)	320
A935	1043	Digital source selection (6ch)	320
A936	1044	Digital source selection (7ch)	320
A937	1045	Digital source selection (8ch)	320
A938	1046	Digital trigger channel	320
A939	1047	Digital trigger operation selection	320

◆ N: Communication operation parameters

Parameters for the setting of communication operation such as the communication specifications or operating characteristics.

Pr. group	Pr.	Name	Refer to page
N000	549	Protocol selection	*2
N001	342	Communication EEPROM write selection	*2
N013	502	Stop mode selection at communication error	*2
N014	779	Operation frequency during communication error	*2
N020	117	RS-485 communication station number	*2
N021	118	RS-485 communication speed	*2
N022	119	RS-485 communication data length	*2
N023	119	RS-485 communication stop bit length	*2
N024	120	RS-485 communication parity check	*2
N025	121	RS-485 communication retry count	*2
N026	122	RS-485 communication check time interval	*2
N027	123	RS-485 communication waiting time setting	*2
N028	124	RS-485 communication CR/LF selection	*2
N040	547	USB communication station number	*2
N041	548	USB communication check time interval	*2
N080	343	Communication error count	*2

◆ (G) Control parameters

Parameters for motor control.

Pr. group	Pr.	Name	Refer to page
G000	0	Torque boost <i>Simple</i>	327
G001	3	Base frequency <i>Simple</i>	329
G002	19	Base frequency voltage	329
G003	14	Load pattern selection	331
G010	46	Second torque boost	327
G011	47	Second V/F (base frequency)	329
G030	60	Energy saving control selection	333
G060	673	SF-PR slip amount adjustment operation selection	334
G061	674	SF-PR slip amount adjustment gain	334
G100	10	DC injection brake operation frequency	335
G101	11	DC injection brake operation time	335
G106	250	Stop selection	258, 338

Pr. group	Pr.	Name	Refer to page
G107	70	Special regenerative brake duty	340
G110	12	DC injection brake operation voltage	335
G111	795	DC injection brake operation current level	335
G120	882	Regeneration avoidance operation selection	345
G121	883	Regeneration avoidance operation level	345
G123	885	Regeneration avoidance compensation frequency limit value	345
G124	886	Regeneration avoidance voltage gain	345
G125	665	Regeneration avoidance frequency gain	345
G130	660	Increased magnetic excitation deceleration operation selection	348
G131	661	Magnetic excitation increase rate	348
G132	662	Increased magnetic excitation current level	348
G200	800	Control method selection	72
G203	245	Rated slip	350
G204	246	Slip compensation time constant	350
G205	247	Constant output range slip compensation selection	350
G211	820	Speed control P gain	90
G212	821	Speed control integral time	90
G213	824	Torque control P gain (current loop proportional gain)	90
G214	825	Torque control integral time (current loop integral time)	90
G225	532	Vibration suppression mode selection	352
G226	533	Vibration suppression response adjustment	352
G227	534	Maximum vibration suppression frequency	352
G228	535	Minimum vibration suppression frequency	352
G410	653	Speed smoothing control	351
G411	654	Speed smoothing cutoff frequency	351
G932	89	Speed control gain (Advanced magnetic flux vector)	75

*1 On the LCD operation panel or the parameter unit used as the command source, the parameter number in parentheses appears instead of that starting with the letter C.

*2 For details, refer to the Instruction Manual (Communication).

4 Control Method

V/F control (initial setting), Advanced magnetic flux vector control, PM sensorless vector control are available with this inverter.

Item	V/F control	Advanced magnetic flux vector control	PM sensorless vector control
Speed control range	1:10 (6 to 60 Hz: power driving)	1:120 (0.5 to 60 Hz: power driving)	1:10 (current synchronization operation)
Speed response	10 to 20 rad/s	20 to 30 rad/s	63 to 314 rad/s (10 to 50 Hz)
Advantage	The inverter controls the output frequency (F) and the output voltage (V) so that the ratio of frequency to voltage (V/F) is kept constant when the frequency is changed. Since the voltage is reduced almost proportional to the speed, the power can be reduced.	The inverter performs vector calculation and divides its output current into the excitation current and the torque current. The inverter compensates the frequency and the voltage to output a current that meets the load torque to the motor, which improves the motor torque at low speed.	The inverter enables highly efficient motor control and highly accurate motor speed control of a PM (permanent magnet embedded) motor, which is more efficient than an induction motor.

◆ V/F control

The inverter controls the output frequency (F) and the output voltage (V) so that the ratio of frequency to voltage (V/F) is kept constant when the frequency is changed.

◆ Advanced magnetic flux vector control

- The inverter performs vector calculation and divide its output current into the excitation current and the torque current. The inverter compensates the frequency and the voltage to output a current that meets the load torque to the motor, which improves the motor torque at low speed. The output frequency is further compensated (slip compensation) to bring the actual motor speed closer to the commanded speed. This control method is useful when the load fluctuates are severe.
- If 150% or more of the low-speed torque is required to be generated, it is recommended that offline auto tuning is performed.

NOTE

- Advanced magnetic flux vector control requires the following conditions.
If these conditions are not satisfied, select V/F control. Otherwise, malfunctions such as insufficient torque, uneven rotation may occur.
- The motor capacity must be the same or one rank lower than the inverter capacity.
If a motor with substantially low rated current compared with the inverter rated current is used, speed and torque accuracies may deteriorate due to torque ripples, etc. Set the rated motor current to about 40% or higher of the inverter rated current. (For details on the inverter rated current, refer to the inverter rated specifications in the Instruction Manual (Connection).)
- The motor described in the following table is used.

Motor	Condition
Mitsubishi Electric standard efficiency motor (SF-JR)	Offline auto tuning is not required.
Mitsubishi Electric high-efficiency motor (SF-HR)	
Mitsubishi Electric constant-torque motor (SF-JRCA 4P, SF-HRCA)	
Mitsubishi Electric high-performance energy-saving motor (SF-PR)	
Other motors (other manufactures' motors)	Offline auto tuning is required.

- Single-motor operation (one motor to one inverter) is performed.
- The wiring length from the inverter to the motor is 15 m or less (as a reference). (When the wiring length exceeds 15 m (as a reference), perform offline auto tuning with the wiring in place.)

◆ PM sensorless vector control

- The inverter enables highly efficient motor control and highly accurate motor speed control of a PM (permanent magnet embedded) motor, which is more efficient than an induction motor.
- A speed detector such as an encoder is not required as the inverter estimates the motor speed by the calculation from the inverter output voltage and current. The inverter drives the PM motor with the least required current for a load in order to achieve the highest motor efficiency.
- When a PM motor EM-A series is used, just performing PM parameter initialization enables PM sensorless vector control.

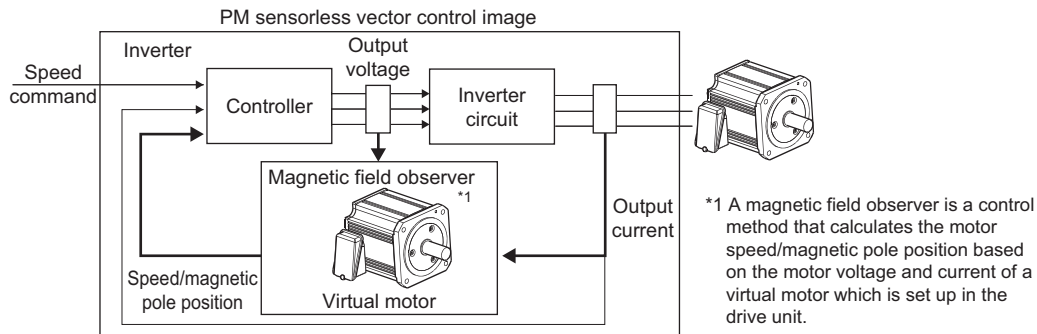

NOTE

- The PM sensorless vector control requires the following conditions.
- The motor described in the following table is used.

Motor	Condition
Mitsubishi Electric PM motor (EM-A)	The offline auto tuning is not required.
IPM motor or PM motor other than the above	The offline auto tuning is required.

- The rated motor current should be equal to or less than the inverter rated current.
If a motor with substantially low rated current compared with the inverter rated current is used, speed accuracy may deteriorate due to torque ripples, etc. Set the rated motor current to about 40% or higher of the inverter rated current. (For details on the inverter rated current, refer to the inverter rated specifications in the Instruction Manual (Connection).)
- Single-motor operation (one motor to one inverter) is performed.
- The wiring length from the inverter to the motor is 30 m or less.
- Even when the EM-A motor is used, if motor wiring is changed after offline auto tuning, perform tuning again.
- A surge voltage suppression filter (FR-ASF/FR-BMF) is not used.

4.1 Changing the control method and mode

Set the control method and the control mode.

V/F control, Advanced magnetic flux vector control, and PM sensorless vector control are available.

Select a control method and a control mode by setting **Pr.800 Control method selection**.

Pr.	Name	Initial value	Setting range	Description
71 C100	Applied motor	0	0, 3, 5, 6, 10, 13, 15, 16, 20, 23, 40, 43, 50, 53, 70, 73, 1140 ^{*3} , 8090, 8093, 9090, 9093	By selecting a standard motor or constant-torque motor, the thermal characteristic and motor constant of each motor are set.
80 C101	Motor capacity	9999	0.1 to 18.5 kW	Set the applied motor capacity.
			9999	No motor capacity setting
81 C102	Number of motor poles	9999	2, 4, 6, 8, 10, 12	Set the number of motor poles.
			9999	No number of motor poles setting
83 C104	Rated motor voltage	200/400 V ^{*1}	0 to 1000 V	Set the rated motor voltage (V).
84 C105	Rated motor frequency	9999	10 to 400 Hz	Set the rated motor frequency (Hz).
			9999	The setting value of Pr.3 Base frequency is used. ^{*2}
800 G200	Control method selection	40	10	PM sensorless vector control
			19	PM sensorless vector control test operation
			20	Advanced magnetic flux vector control
			40	V/F control

*1 The initial value differs according to the inverter's voltage class (100 V or 200/400 V).

*2 The inverter internal data is used under PM sensorless vector control.

*3 The value is valid in any of the following conditions. Under other conditions, "SE" (Incorrect parameter setting) is displayed when the start command is turned ON.

The FR-D820-11K-450 or lower is used and **Pr.80** ≤ 7.5 kW.

The FR-D840-11K-230 or lower is used and **Pr.80** = 0.4 to 7.5 kW.

The FR-D820S-2.2K-100 or lower is used and **Pr.80** ≤ 2.2 kW.

The FR-D810W-0.75K-042 or lower is used and **Pr.80** ≤ 0.75 kW.

◆ Setting the motor capacity and the number of motor poles (Pr.80, Pr.81)

- Motor specifications (the motor capacity and the number of motor poles) must be set to select Advanced magnetic flux vector control or PM sensorless vector control.
- Set the motor capacity (kW) in **Pr.80 Motor capacity** and set the number of motor poles in **Pr.81 Number of motor poles**.

◆ Selection of the control method and the control mode

- Select a control method (and a control mode) from V/F control, Advanced magnetic flux vector control (speed control), and PM sensorless vector control (speed control).
- To enable the control method and the control mode selected in **Pr.800**, the condition to start operation must be satisfied as shown in the following table. Otherwise the operation does not start due to the setting error (SE) alarm when the start signal is input.

Pr.800 setting	Control method	Control mode	Condition to start operation	
			Pr.80, Pr.81	Pr.71 (Pr.450)
10	PM sensorless vector control	Speed control	Other than 9999	PM motor ^{*1}
19	PM sensorless vector control test operation			
20	Advanced magnetic flux vector control	Speed control		
40 (initial value)	V/F control	—	— ^{*2}	Induction motor

*1 Only **Pr.71** can be set.

*2 Operation can start regardless of the setting.

◆ PM sensorless vector control test operation (Pr.800 = "19")

- A test operation for speed control is available without connecting a motor to the inverter.
The speed calculation changes to track the speed command, and such speed changes can be checked on the operation panel or by outputting it as analog signals to terminal AM.

NOTE

- Since current is not detected and voltage is not output, monitors related to current and voltage such as output current and output voltage, etc. and output signals do not function.

◆ I/O signal status during the test operation

- During the test operation, the following signals are disabled.

Input terminal function selection (Pr.178 to Pr.182, Pr.185 to Pr.189)	Output terminal function selection (Pr.190 to Pr.196)
• V/F switchover (X18)	• Electronic thermal O/L relay pre-alarm (THP)

Parameters referred to

Pr.178 to Pr.182 and Pr.185 to Pr.189 (Input terminal function selection) [page 252](#)

Pr.190 to Pr.196 (Output terminal function selection) [page 226](#)

◆ Status of the monitoring during the test operation

○: Enabled

×: Disabled (0 is displayed at any time.)

Δ: A cumulative total before the test operation is displayed.

—: Not available

Monitor item	Monitoring on the operation panel	Output via AM	Monitor item	Monitoring on the operation panel	Output via AM
Output frequency	○	○	Cumulative energy	Δ	—
Output current	×	×	Commanded torque	×	×
Output voltage	×	×	Torque current command	×	×
Fault indication	○	—	Heat sink temperature	○	○
Frequency setting value	○	○	Trace status	○	—
Motor speed	○	○	Station number (RS-485 communication)	○	—
Motor torque	×	×	Energy saving effect	Δ ^{*3}	Δ ^{*3}
Converter output voltage	○	○	Cumulative energy saving	Δ	—
Brake duty	○	○	PID set point	○	○
Electronic thermal O/L relay load factor	× ^{*1}	× ^{*1}	PID measured value	○	○
Output current peak value	× ^{*1}	× ^{*1}	PID deviation	○	—
Converter output voltage peak value	○	○	Inverter I/O terminal monitor	○	—
Input power	×	×	Motor thermal load factor	× ^{*1}	× ^{*1}
Output power	×	×	Inverter thermal load factor	○ ^{*2}	○ ^{*2}
Load meter	×	×	PTC thermistor value	○	—
Motor excitation current	×	×	PID measured value 2	○	○
Cumulative energization time	○	—	Emergency drive status	○	—
Reference voltage output	—	○	PID manipulated variable	○	—
Actual operation time	○	—	Dancer main speed setting	○	○
Motor load factor	×	×	Control circuit temperature	○	○

*1 When the inverter operation is switched to the test operation, the indication is changed to 0. When PM sensorless vector control is selected again after a test operation, the following monitor items from the last operation are displayed: output current peak value, electronic thermal relay load factor, and motor thermal load factor.

*2 When the inverter operation is switched to the test operation, the accumulated thermal value is reduced because the output current is considered as 0.

*3 During the test operation, only the average power saving, average power saving rate, and average power cost savings/average CO₂ emission reduction can be monitored.

«Parameters referred to»

Operation panel main monitor selection [page 208](#)

Pr.158 AM terminal function selection [page 216](#)

◆ Changing the control method with external terminals (RT signal, X18 signal)

- Control method (V/F control or Advanced magnetic flux vector control) can be switched using external terminals. The control method can be switched using either the Second function selection (RT) signal or the V/F switchover (X18) signal.
- Set the second motor in **Pr.450 Second applied motor**. Turning ON the RT signal or X18 signal enables the second function, enabling the switchover of the control method.
- To input the RT signal, set "3" in any parameter from **Pr.178 to Pr.182 and Pr.185 to Pr.189 (Input terminal function selection)** to assign the function.
To input the X18 signal, set "18" in any parameter from **Pr.178 to Pr.182 and Pr.185 to Pr.189 (Input terminal function selection)** to assign the function.

First motor control method	Second motor control method (RT/X18 signal-ON)	Pr.450 setting
V/F control	V/F control	9999
		Induction motor
Advanced magnetic flux vector control ^{*1}	Same control as the first motor ^{*1}	9999
	V/F control	Induction motor

*1 V/F control is set by turning ON the X18 signal.

NOTE

- The RT signal is the Second function selection signal. The RT signal also enables other second functions. (Refer to [page 257](#).)
- When V/F control is set using the V/F switchover (X18) signal, the second functions are selected at the same time.
- The control method could be changed by external terminals (RT signal, X18 signal) while the inverter is stopped. If a signal is switched during the operation, the control method changes after the inverter stops.

«Parameters referred to»

Pr.178 to Pr.182 and Pr.185 to Pr.189 (Input terminal function selection) [page 252](#)

Pr.450 Second applied motor [page 261](#)

Pr.804 Torque limit command source selection [page 87](#)

Pr.810 Torque limit input method selection [page 87](#)

4.2 Selecting the Advanced magnetic flux vector control

Magnetic flux

Point

- To use the Advanced magnetic flux vector control, select the control method using **Pr.800**, and the motor type and specification using **Pr.71**, **Pr.80**, and **Pr.81**.

◆ Advanced magnetic flux vector control

4

Operating procedure

1. Perform wiring properly. (Refer to the Instruction Manual (Connection).)
2. Change the control method to Advanced magnetic flux vector control (**Pr.800** = "20").
3. Make the motor setting (**Pr.71**).

Motor	Pr.71 setting ^{*1}	Remarks	
Mitsubishi Electric standard efficiency motor	SF-JR	0 (initial value) (3)	
	SF-JR 4P 1.5 kW or lower	20	
Mitsubishi Electric high-efficiency motor	SF-HR	40	
	Others	0 (3)	Offline auto tuning is required. ^{*2}
Mitsubishi Electric constant-torque motor	SF-JRCA 4P	10	
	SF-HRCA	50	
	Other (SF-JRC, etc.)	10 (13)	Offline auto tuning is required. ^{*2}
Mitsubishi Electric high-performance energy-saving motor	SF-PR	70 (73)	
Other manufacturer's standard motor	—	0 (3)	Offline auto tuning is required. ^{*2}
Other manufacturer's constant-torque motor	—	10 (13)	Offline auto tuning is required. ^{*2}

*1 For the other setting values of **Pr.71**, refer to [page 261](#).

*2 For offline auto tuning (**Pr.96**), refer to [page 266](#).

4. Set the motor overheat protection (**Pr.9**). (Refer to [page 166](#).)
5. Set the motor capacity and number of motor poles (**Pr.80**, **Pr.81**). (Refer to [page 72](#).)
Operation does not start when the setting value is "9999 (initial value)".
6. Set the rated motor voltage and frequency (**Pr.83**, **Pr.84**). (Refer to [page 266](#).)
7. Set the operation command. (Refer to [page 142](#).)
Select the start command and speed command.
8. Perform the test operation.

As required

- Perform the offline auto tuning (**Pr.96**). (Refer to [page 266](#).)

NOTE

- Under this control, rotations are more likely to be uneven than under V/F control. (This control method is not suitable for grinder, wrapping machine, etc., which require even rotation at a low speed.)
- When the inverter is operated with a surge voltage suppression filter (FR-ASF-H/FR-BMF-H) installed between the inverter and the motor, the output torque may decrease.

◆ Keeping the motor speed constant when the load fluctuates (speed control gain)

Pr.	Name	Initial value	Setting range	Description
89 G932	Speed control gain (Advanced magnetic flux vector)	9999	0% to 200%	Makes adjustments to keep the motor speed constant during variable load operation under Advanced magnetic flux vector control. The reference value is 100%.
			9999	The gain set by Pr.71 . (The gain set in accordance with the motor.)

- Use **Pr.89** to keep the motor speed constant during variable load operation. (This parameter is useful to make adjustments on the motor speed after replacing a conventional model with an FR-D800 series model.)
- The initial value of **Pr.89** is "9999". Set the value to 100% to use the function.
- When the actual motor speed is lower than the speed command, increase the setting value by 1% to 10%.
- When the actual motor speed is higher than the speed command, decrease the setting value by 1% to 10%.
- Adjust the minimum increment according to the difference between the actual speed and the speed command.
- If hunting, overshooting, or undershooting occurs for the actual motor speed in relation to the speed command, set a smaller value or "0" in **Pr.89** to disable slip compensation.

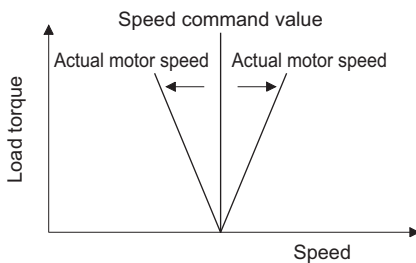

◀ Parameters referred to ▶

Pr.71 Applied motor [page 261](#)

Pr.800 Control method selection [page 72](#)

4.3 Selecting the PM sensorless vector control

PM

Two methods of the motor parameter initialization are available for the use of EM-A motor: using **Pr.998 PM parameter initialization**, and using PM parameter initialization ("PM").

◆ Initializing the parameters required for the PM sensorless vector control (Pr.998)

- Use PM parameter initialization to set the parameters required for driving a PM motor.
- The offline auto tuning enables the operation with a PM motor other than the EM-A. (Refer to [page 266](#).)
- All the parameters required for PM motor control are automatically set by setting **Pr.998** ≠ "0".

Pr.	Name	Initial value	Setting range	Description	
998 E430	PM parameter initialization	0	0	Parameter setting (in frequencies) for an induction motor	The setting of the motor parameters is changed to the setting required to drive an induction motor.
			3044* ¹	Parameter setting (in rotations per minute) for an EM-A motor	The setting of the motor parameters is changed to the setting required to drive a PM motor.
			3144* ¹	Parameter setting (in frequencies) for an EM-A motor	
			8009	Parameter setting (in rotations per minute) for an IPM motor (after tuning)	The setting of the motor parameters is changed to the setting required to drive an IPM motor. (Set Pr.71 Applied motor and perform offline auto tuning in advance. (Refer to page 274 .)
			8109	Parameter setting (in frequencies) for an IPM motor (after tuning)	
			9009	Parameter setting (in rotations per minute) for a PM motor (after tuning)	The setting of the motor parameters is changed to the setting required to drive a PM motor. (Set Pr.71 Applied motor and perform offline auto tuning in advance. (Refer to page 274 .)
			9109	Parameter setting (in frequencies) for a PM motor (after tuning)	

*1 The value can be set in either of the following conditions.
 The FR-D820-11K-450 or lower is used and **Pr.80** ≤ 7.5 kW.
 The FR-D820-7.5K-318 or lower is used and **Pr.80** = "9999".
 The FR-D840-11K-230 or lower is used and **Pr.80** = 0.4 to 7.5 kW.
 The FR-D840-7.5K-163 or lower is used and **Pr.80** = "9999".
 The FR-D820S-2.2K-100 or lower is used and **Pr.80** ≤ 2.2 kW or **Pr.80** = "9999".
 The FR-D810W-0.75K-042 or lower is used and **Pr.80** ≤ 0.75 kW or **Pr.80** = "9999".

- To use a motor capacity that is one rank lower than the inverter capacity, set **Pr.80 Motor capacity** before performing PM parameter initialization.
- When "3044, 8009, or 9009" is set in **Pr.998**, the motor speed which was set/monitored in frequencies is set/monitored in motor rotations per minute. To set/monitor in frequencies, set "3144, 8109, or 9109" in **Pr.998**.
- Set **Pr.998** = "0" to change the PM sensorless vector control parameter settings to the parameter settings required to drive an induction motor.
- When using a PM motor other than the EM-A, set "8009, 8109, 9009, or 9109" in **Pr.998**.

NOTE

- Make sure to set **Pr.998** before setting other parameters. If the **Pr.998** setting is changed after setting other parameters, some of those parameters are initialized too. (Refer to the "List of the target parameters for the motor parameter initialization".)
- To change back to the parameter settings required to drive an induction motor, perform Parameter clear or All parameter clear.
- Whenever the setting of **Pr.998 PM parameter initialization** is changed from "3044, 8009, or 9009 (rotations per minute)" to "3144, 8109, or 9109 (frequency)", and vice versa, all the relevant parameters are initialized.
 The purpose of Pr.998 is not to change the display units. Use **Pr.53 Frequency / rotation speed unit switchover** to change the display units between rotations per minute and frequency. Using **Pr.53** enables switching the unit between rotations per minute and frequencies without initializing the setting of the motor parameters.

◆ List of the target parameters for the motor parameter initialization

- The settings of the parameters in the following table are changed to the settings for PM sensorless vector control by performing the motor parameter initialization using **Pr.998 PM parameter initialization**. The changed settings differ according to the specification (capacity) of the PM motor used.
- Performing Parameter clear or All parameter clear resets these parameter settings to the settings required to drive an induction motor.
- PM motor (EM-A)

Pr.	Name	Setting			Setting increments		
		Induction motor		PM motor (rotations per minute)	PM motor (frequency)	3044	0, 3144
		0 (initial value) ^{*1}		3044 (EM-A)	3144 (EM-A)		
Gr.1	Gr.2						
1	Maximum frequency	120 Hz		Maximum motor rotations per minute ^{*2}	Maximum motor frequency ^{*2}	1 r/min	0.01 Hz
4	Multi-speed setting (high speed)	60 Hz	50 Hz	Rated motor rotations per minute ^{*2}	Rated motor frequency ^{*2}	1 r/min	0.01 Hz
9	Electronic thermal O/L relay	Inverter rated current		Rated motor current ^{*2}		0.01 A	
10	DC injection brake operation frequency	3 Hz		Rated motor rotations per minute ^{*2} × 3%	Rated motor frequency ^{*2} × 3%	1 r/min	0.01 Hz
13	Starting frequency	0.5 Hz		Rated motor rotations per minute ^{*2} × 10%	Rated motor frequency ^{*2} × 10%	1 r/min	0.01 Hz
15	Jog frequency	5 Hz		Rated motor rotations per minute ^{*2} × 10%	Rated motor frequency ^{*2} × 10%	1 r/min	0.01 Hz
18	High speed maximum frequency	120 Hz		Maximum motor rotations per minute ^{*2}	Maximum motor frequency ^{*2}	1 r/min	0.01 Hz
20	Acceleration/deceleration reference frequency	60 Hz	50 Hz	Rated motor rotations per minute ^{*2}	Rated motor frequency ^{*2}	1 r/min	0.01 Hz
22	Stall prevention operation level	150% ^{*3}		200%		0.1%	
42	Output frequency detection	6 Hz		Rated motor rotations per minute ^{*2} × 6%	Rated motor frequency ^{*2} × 6%	1 r/min	0.01 Hz
53	Frequency / rotation speed unit switchover	0		1	0	1	
55	Frequency monitoring reference	60 Hz	50 Hz	Rated motor rotations per minute ^{*2}	Rated motor frequency ^{*2}	1 r/min	0.01 Hz
56	Current monitoring reference	Inverter rated current		Rated motor current ^{*2}		0.01 A	
71	Applied motor	0		1140		1	
72	PWM frequency selection	1		4		1	
80	Motor capacity	9999		Applicable motor capacity (ND) ^{*4}		0.01 kW	
81	Number of motor poles	9999		Number of motor poles ^{*2}		1	
84	Rated motor frequency	9999		Rated motor rotations per minute ^{*2}	Rated motor frequency ^{*2}	1 r/min	0.01 Hz
125 (903)	Terminal 2 frequency setting gain frequency	60 Hz	50 Hz	Rated motor rotations per minute ^{*2}	Rated motor frequency ^{*2}	1 r/min	0.01 Hz
126 (905)	Terminal 4 frequency setting gain frequency	60 Hz	50 Hz	Rated motor rotations per minute ^{*2}	Rated motor frequency ^{*2}	1 r/min	0.01 Hz
240	Soft-PWM operation selection	1		0		1	
374	Overspeed detection level	9999		Maximum motor rotations per minute ^{*2} × 115%	Maximum motor frequency ^{*2} × 115%	1 r/min	0.01 Hz
386	Frequency for maximum input pulse	60 Hz	50 Hz	Rated motor rotations per minute ^{*2}	Rated motor frequency ^{*2}	1 r/min	0.01 Hz
557	Current average value monitor signal output reference current	Inverter rated current		Rated motor current ^{*2}		0.01 A	
665	Regeneration avoidance frequency gain	100.0%		80.0%		0.1%	
800	Control method selection	40		10		1	
820	Speed control P gain	25%		30%		1%	

Pr.	Name	Setting			Setting increments		
		Induction motor		PM motor (rotations per minute)	PM motor (frequency)		
		0 (initial value) ^{*1}		3044 (EM-A)	3144 (EM-A)	3044	0, 3144
		Gr.1	Gr.2				
821	Speed control integral time	0.333 s		0.333 s		0.001 s	
824	Torque control P gain (current loop proportional gain)	50%		150%		1%	
825	Torque control integral time (current loop integral time)	20 ms		6.7 ms		0.1 ms	
865	Low speed detection	1.5 Hz		Rated motor rotations per minute ^{*2} × 2.5%	Rated motor frequency ^{*2} × 2.5%	1 r/min	0.01 Hz
870	Speed detection hysteresis	0 Hz		Rated motor rotations per minute ^{*2} × 0.5%	Rated motor frequency ^{*2} × 0.5%	1 r/min	0.01 Hz
885	Regeneration avoidance compensation frequency limit value	6 Hz		Rated motor rotations per minute ^{*2} × 6%	Rated motor frequency ^{*2} × 6%	1 r/min	0.01 Hz
893	Energy saving monitor reference (motor capacity)	Applicable motor capacity		Motor capacity (Pr.80)		0.01 kW	

*1 Gr.1 and Gr.2 are the parameter initial value groups. (Refer to page 46.)

*2 When "9999" is set in the corresponding parameter, the value shown in the following table is used. When a value other than "9999" is set, the set value is used without change.

Setting	EM-A		Corresponding parameter
	0.75 kW or lower	1.5 kW or higher	
Rated motor rotations per minute (frequency)	3000 r/min (100 Hz)	3000 r/min (150 Hz)	Pr.84
Maximum motor rotations per minute (frequency)	4000 r/min (133.33 Hz)	4000 r/min (200 Hz)	Pr.702
Number of motor poles	4	6	Pr.81
Rated motor current	Refer to the Instruction Manual (Connection).		Pr.859

*3 110% for SLD rating and 150% for ND rating (Refer to Pr.570 Multiple rating setting on page 108.)

*4 When a value other than "9999" is set in Pr.80, the set value is used without change.

- PM motor other than the EM-A

Pr.	Name	Setting			Setting increments		
		Induction motor		PM motor (rotations per minute)			PM motor (frequency)
		0 (initial value) ^{*1}		8009, 9009	8109, 9109	8009, 9009	0, 8109, 9109
		Gr.1	Gr.2				
1	Maximum frequency	120 Hz		Maximum motor rotations per minute ^{*3}	Maximum motor frequency ^{*3}	1 r/min	0.01 Hz
4	Multi-speed setting (high speed)	60 Hz	50 Hz	Pr.84	Pr.84	1 r/min	0.01 Hz
9	Electronic thermal O/L relay	Inverter rated current		—	—	0.01 A	0.01 A
10	DC injection brake operation frequency	3 Hz		3 Hz ^{*4}	3 Hz	1 r/min	0.01 Hz
13	Starting frequency	0.5 Hz		Pr.84 × 10%	Pr.84 × 10%	1 r/min	0.01 Hz
15	Jog frequency	5 Hz		Pr.84 × 10%	Pr.84 × 10%	1 r/min	0.01 Hz
18	High speed maximum frequency	120 Hz		Maximum motor rotations per minute ^{*3}	Maximum motor frequency ^{*3}	1 r/min	0.01 Hz
20	Acceleration/deceleration reference frequency	60 Hz	50 Hz	Pr.84	Pr.84	1 r/min	0.01 Hz
22	Stall prevention operation level	150% ^{*2}		150% ^{*2}	150% ^{*2}	0.1%	0.1%
42	Output frequency detection	6 Hz		6 Hz ^{*4}	6 Hz	1 r/min	0.01 Hz
53	Frequency / rotation speed unit switchover	0		1	0	1	1
55	Frequency monitoring reference	60 Hz	50 Hz	Pr.84	Pr.84	1 r/min	0.01 Hz
56	Current monitoring reference	Inverter rated current		Pr.859	Pr.859	0.01 A	0.01 A
71	Applied motor	0		—	—	1	1
72	PWM frequency selection	1		2	2	1	1
80	Motor capacity	9999		—	—	0.01 kW	0.01 kW
81	Number of motor poles	9999		—	—	1	1
84	Rated motor frequency	9999		—	—	1 r/min	0.01 Hz
125 (903)	Terminal 2 frequency setting gain frequency	60 Hz	50 Hz	Pr.84	Pr.84	1 r/min	0.01 Hz
126 (905)	Terminal 4 frequency setting gain frequency	60 Hz	50 Hz	Pr.84	Pr.84	1 r/min	0.01 Hz
240	Soft-PWM operation selection	1		0	0	1	1
374	Overspeed detection level	9999		Maximum motor frequency + 10 Hz ^{*3*4}	Maximum motor frequency + 10 Hz ^{*3}	1 r/min	0.01 Hz
386	Frequency for maximum input pulse	60 Hz	50 Hz	Pr.84	Pr.84	1 r/min	0.01 Hz
557	Current average value monitor signal output reference current	Inverter rated current		Pr.859	Pr.859	0.01 A	0.01 A
665	Regeneration avoidance frequency gain	100.0%		100.0%	100.0%	0.1%	0.1%
800	Control method selection	40		10	10	1	1
820	Speed control P gain	25%		25%	25%	1%	1%
821	Speed control integral time	0.333 s		0.333 s	0.333 s	0.001 s	0.001 s
824	Torque control P gain (current loop proportional gain)	50%		50%	50%	1%	1%
825	Torque control integral time (current loop integral time)	20 ms		20 ms	20 ms	0.1 ms	0.1 ms
865	Low speed detection	1.5 Hz		1.5 Hz ^{*4}	1.5 Hz	1 r/min	0.01 Hz
870	Speed detection hysteresis	0 Hz		0.5 Hz ^{*4}	0.5 Hz	1 r/min	0.01 Hz
885	Regeneration avoidance compensation frequency limit value	6 Hz		Pr.84 × 10%	Pr.84 × 10%	1 r/min	0.01 Hz
893	Energy saving monitor reference (motor capacity)	Applicable motor capacity		Motor capacity (Pr.80)	Motor capacity (Pr.80)	0.01 kW	0.01 kW

—: Not changed

*1 Gr.1 and Gr.2 are the parameter initial value groups. (Refer to page 46.)

*2 110% for SLD rating and 150% for ND rating (Refer to **Pr.570 Multiple rating setting** on page 108.)

*3 **Pr.702 Maximum motor frequency** is used as the maximum motor frequency (rotations per minute). When **Pr.702** = "9999 (initial value)", **Pr.84 Rated motor frequency** is used as the maximum motor frequency (rotations per minute).

*4 The setting value is converted from frequency to rotations per minute. (It differs according to the number of motor poles.)

NOTE

- When the motor parameter initialization is performed with the setting in units of rotations per minute (**Pr.998** = "3044, 8009, or 9009"), the parameters not listed in the table and the monitor items are also set and displayed in rotations per minute.

◆ Setting for the PM sensorless vector control by selecting PM parameter initialization on the operation panel ("PM")

Point

- The parameters required to drive a PM motor (EM-A) are automatically set by batch. (Refer to [page 78](#).)
- The PM LED on the operation panel turns ON when the PM sensorless vector control is set.

The following shows the procedure to initialize the parameter settings for an EM-A motor by selecting PM parameter initialization on the operation panel.

Operating procedure

- 1.** Turning ON the power of the inverter
The operation panel is in the monitor mode.
- 2.** Changing the operation mode
Press the HAND/AUTO key to choose the PU operation mode.
The HAND LED turns ON.
- 3.** Selecting the parameter setting mode
Press the MODE key to choose the parameter setting mode.
The PRM LED is ON.
- 4.** PM parameter initialization
Turn the setting dial until "PM" (PM parameter initialization) appears.
- 5.** Displaying the set value
Press the SET key to read the present set value.
The value set in **Pr.998** is displayed.
- 6.** Changing the setting value
Turn the setting dial to change the value to "3044", and the SET key to confirm it.
"3044" and "PM" are displayed alternately. The setting is completed.

Setting	Description
0 (initial value)	Parameter setting (in frequencies) for an induction motor
3044	Parameter setting (in rotations per minute) for an EM-A motor

NOTE

- If the motor parameter initialization is performed by using PM parameter initialization for the use of a PM motor, the setting of **Pr.998 PM parameter initialization** is also changed automatically.
- In the initial parameter setting, the capacity same as the inverter capacity is set in **Pr.80 Motor capacity**. To use a motor capacity that is one rank lower than the inverter capacity, set **Pr.80** before performing PM parameter initialization.
- Use **Pr.998** to set a speed by adjusting frequencies or to monitor it, or to drive a PM motor other than the EM-A. (Refer to [page 77](#).)

◆ Setting for the V/F control by selecting PM parameter initialization on the operation panel ("PM")

Point

- When the control method is changed from PM sensorless vector control to V/F control, all the parameter settings required to drive an induction motor are automatically set. (Refer to [page 78](#).)

The following shows the procedure to change the control method from PM sensorless vector control to V/F control by selecting PM parameter initialization on the operation panel.

Operating procedure

- 1.** Turning ON the power of the inverter
The operation panel is in the monitor mode.
- 2.** Changing the operation mode
Press the HAND/AUTO key to choose the PU operation mode.
The HAND LED turns ON.
- 3.** Selecting the parameter setting mode
Press the MODE key to choose the parameter setting mode.
The PRM LED is ON.
- 4.** PM parameter initialization
Turn the setting dial until "PM" (PM parameter initialization) appears.
- 5.** Displaying the set value
Press the SET key to read the present set value.
The value set in **Pr.998** is displayed.
- 6.** Changing the setting value
Turn the setting dial to change the value to "0", and the SET key to confirm it.
"0" blinks. The setting is completed.

NOTE

- If PM parameter initialization is selected on the operation panel to set V/F control, the setting of **Pr.998 PM parameter initialization** is also changed automatically.
- The changed parameter settings are the same as those when **Pr.998 = "0"**.

5 Speed control under PM sensorless vector control

Purpose	Parameter to set			Refer to page
To limit the torque during speed control	Torque limit	P.D030, P.H500, P.H700, P.H710, P.H730, P.M430	Pr.22, Pr.157, Pr.810, Pr.811, Pr.815, Pr.874	87
To adjust the speed control gain	Speed control P gain, speed control integral time	P.G211 to P.G214, P.C114	Pr.820, Pr.821, Pr.824, Pr.825	90
To reduce the unstable movements or the error occurrence	Voltage compensation amount setting	P.E386	Pr.643	93

This chapter explains the speed control under PM sensorless vector control. Speed control performs control so that the speed command and the actual motor rotation speed match.

◆ Control block diagram

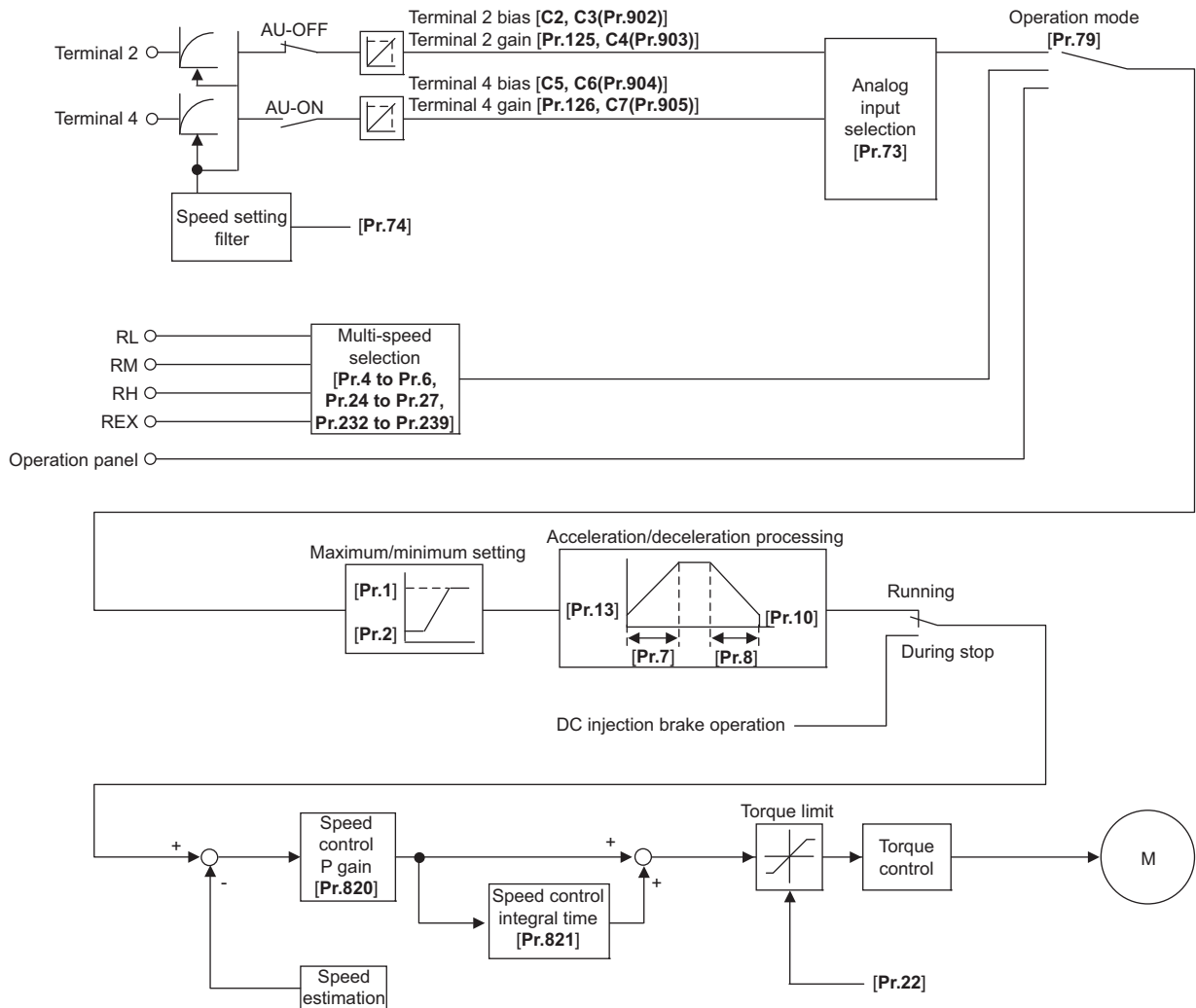

5.1 Setting procedure of PM sensorless vector control (speed control)

PM

This inverter is set for an induction motor in the initial setting. Follow the following procedure to change the setting for the PM sensorless vector control.

◆ When using a PM motor (EM-A)

Operating procedure

1. Perform wiring properly. (Refer to the Instruction Manual (Connection).)
2. Perform PM parameter initialization. (Refer to [page 77](#).)
Set "3044 or 3144" in **Pr.998 PM parameter initialization**, or select "PM" (PM parameter initialization) and set "3044" on the operation panel.
To use a motor capacity that is one rank lower than the inverter capacity, set **Pr.80 Motor capacity** before performing PM parameter initialization.

Setting	Description
3044	Parameter setting (in rotations per minute) for an EM-A motor
3144	Parameter setting (in frequencies) for an EM-A motor

3. Set parameters such as the acceleration/deceleration time and multi-speed setting.
Set parameters such as the acceleration/deceleration time and multi-speed setting as required.
4. Set the operation command. (Refer to [page 142](#).)
Select the start command and speed command.
5. Perform the test operation.

NOTE

- To change to the PM sensorless vector control, perform PM parameter initialization first. If parameter initialization is performed after setting other parameters, some of those parameters are initialized too. (Refer to [page 78](#) for the parameters that are initialized.)
- The carrier frequency is limited during PM sensorless vector control. (Refer to [page 120](#).)
- During PM sensorless vector control, the RUN signal is output about 100 ms after turning ON the start command (STF, STR). The delay is due to the magnetic pole detection.
- In the low-speed range, torque ripples or uneven rotation occur. Adjust the setting of **Pr.820 Speed control P gain** as required.

◆ When using a PM motor (other than the EM-A)

Operating procedure

1. Set the applied motor (**Pr.9**, **Pr.71**, **Pr.80**, **Pr.81**, **Pr.83**, and **Pr.84**). (Refer to [page 261](#), [page 274](#).)
Set "8093" (IPM motor) or "9093" (PM motor) in **Pr.71 Applied motor**. Set **Pr.9 Rated motor current**, **Pr.80 Motor capacity**, **Pr.81 Number of motor poles**, **Pr.83 Rated motor voltage**, and **Pr.84 Rated motor frequency** according to the motor specifications. (Operation does not start when the setting values of **Pr.80** and **Pr.81** are "9999 (initial value)".)
2. Select the PM sensorless vector control (**Pr.800**). (Refer to [page 72](#).)
The PM LED on the operation panel turns ON when the PM sensorless vector control is set by setting **Pr.800** = "10".
3. Perform the offline auto tuning for a PM motor (**Pr.96**). (Refer to [page 274](#).)
Set "1" (offline auto tuning without rotating motor) in **Pr.96**, and perform tuning.
4. Configure the initial setting for the PM sensorless vector control using **Pr.998**. (Refer to [page 77](#).)
When the setting for the PM motor is selected in **Pr.998 PM parameter initialization**, all the parameters required for PM sensorless vector control are automatically set.

Setting	Description
8009	Parameter settings (in rotations per minute) for an IPM motor
8109	Parameter settings (in frequencies) for an IPM motor
9009	Parameter settings (in rotations per minute) for a PM motor
9109	Parameter settings (in frequencies) for a PM motor

5. Set parameters such as the acceleration/deceleration time and multi-speed setting.
Set parameters such as the acceleration/deceleration time and multi-speed setting as required.
6. Set the operation command. (Refer to [page 142](#).)
Select the start command and speed command.
7. Perform the test operation.

NOTE

- To change to the PM sensorless vector control, perform PM parameter initialization after offline auto tuning. If parameter initialization is performed after setting other parameters, some of those parameters are initialized too. (Refer to [page 78](#) for the parameters that are initialized.)
- To use a motor capacity that is one rank lower than the inverter capacity, set **Pr.80 Motor capacity** before performing PM parameter initialization.
- The carrier frequency is limited during PM sensorless vector control. (Refer to [page 120](#).)
- The protective function may be activated due to insufficient torque in the low-speed range of less than 10% of the rated motor frequency. The torque limit is not activated.
- During PM sensorless vector control, the RUN signal is output about 100 ms after turning ON the start command (STF, STR). The delay is due to the magnetic pole detection.
- In the low-speed range, torque ripples or uneven rotation occur. Adjust the setting of **Pr.820 Speed control P gain** as required.

5.2 Setting the torque limit level

PM

Limit the output torque not to exceed the specified value.

The torque limit level can be set in a range of 0% to 400%. The TL signal can be used to switch between two types of torque limit.

Pr.	Name	Initial value	Setting range	Description
22 H500	Stall prevention operation level (Torque limit level)	150%	0% to 400%	Set the torque limit level as a percentage with regards to the rated torque as 100%.
157 M430	OL signal output timer	0 s	0 to 25 s	Set the OL signal output start time at the activation of torque limit operation.
			9999	No OL signal output.
810 H700	Torque limit input method selection	0	0	Internal torque limit 1 (torque limited by parameter settings)
811 D030	Set resolution switchover	0	0	Torque limit setting increments 0.1%
			10	Torque limit setting increments 0.01%
815 H710	Torque limit level 2	9999	0% to 400%	When the torque limit selection (TL) signal is ON, Pr.815 is the torque limit value regardless of Pr.810.
			9999	The torque limit set to Pr.810 is valid.
874 H730	OLT level setting	150%	0% to 400%	The inverter can be set to be shut off at activation of torque limit and stalling of the motor. Set the output to be shut off.

NOTE

- The torque limit is not activated in a low-speed range of less than 10% of the rated motor frequency.
- The torque limit level is reduced inversely proportional to the output frequency in the constant output range of the rated motor frequency or higher.

◆ Block diagram of torque limit

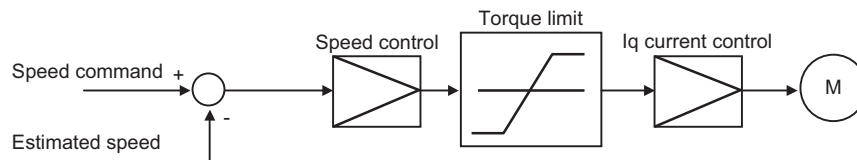

◆ Internal torque limit 1 (Pr.810 = "0")

- The torque is limited by Pr.22 Stall prevention operation level (Torque limit level).
- If changing the torque limit parameters via communication is enabled, the torque limit input can be performed via communication.

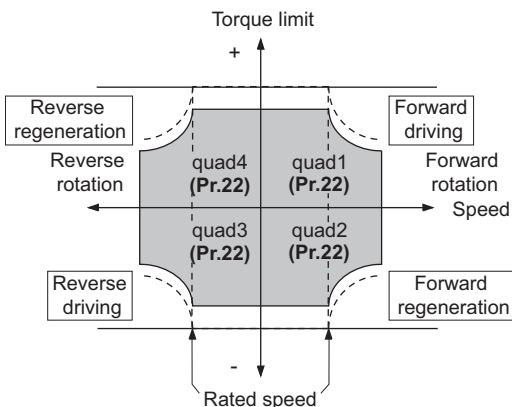

◆ Second torque limit level (TL signal, Pr.815)

- For **Pr.815 Torque limit level 2**, when the Torque limit selection (TL) signal is ON, the setting value of **Pr.815** is the limit value regardless of the setting of **Pr.810 Torque limit input method selection**.
- To assign the TL signal, set "27" in any parameter from **Pr.178 to Pr.182 and Pr.185 to Pr.189 (Input terminal function selection)**.

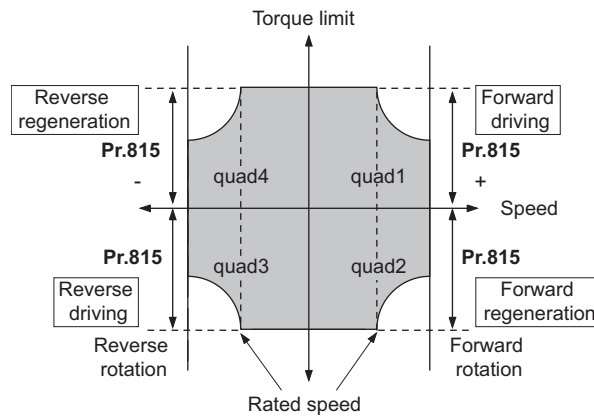

NOTE

- Changing the terminal assignment using **Pr.178 to Pr.182 and Pr.185 to Pr.189 (Input terminal function selection)** may affect the other functions. Set parameters after confirming the function of each terminal.

◆ Changing the setting increments of the torque limit level (Pr.811)

- The setting increments of **Pr.22 Torque limit level** and **Pr.815 Torque limit level 2** can be changed to 0.01% by setting **Pr.811 Set resolution switchover = "10"**.

Pr.811 setting	Torque limit setting increments
0 (initial value)	0.1%
10	0.01%

NOTE

- The internal resolution of the torque limit is 0.024% ($100/2^{12}$), and fractions below this resolution are rounded off.

◆ Trip during torque limit operation (Pr.874)

- The inverter can be set to be shut off at activation of torque limit and stalling of the motor.
- When a high load is applied and the torque limit is activated under speed control, the motor stalls. At this time, if the rotation speed is lower than the value set in **Pr.865 Low speed detection** and the output torque exceeds the level set in **Pr.874 OLT level setting**, and this state continues for 3 seconds, Stall prevention stop (E.OLT) is activated and the inverter output is shut off.

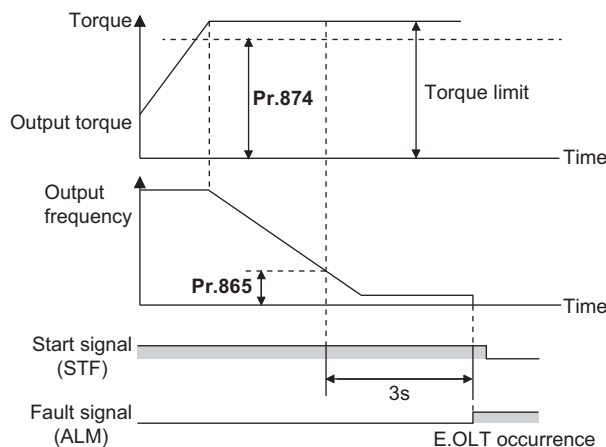

NOTE

- Under V/F control or Advanced magnetic flux vector control, if the output frequency drops to 1 Hz due to the stall prevention operation and this state continues for 3 seconds, a fault indication (E.OLT) appears, and the inverter output is shut off. This operation is activated regardless of the **Pr.874** setting.

◆ Adjusting the signal output under torque limit operation and output timing (OL signal, Pr.157)

- If the output torque exceeds the torque limit level and the torque limit is activated, the overload warning (OL signal) is turned ON for 100 ms or longer. When the output torque drops to the torque limit level or lower, the output signal also turns OFF.
- Pr.157 OL signal output timer** can be used to set whether to output the OL signal immediately, or whether to output it after a certain time period has elapsed.
- For the OL signal, set "3" (positive logic) or "103" (negative logic) in any parameter from **Pr.190 to Pr.196 (Output terminal function selection)** to assign the function to an output terminal.

Pr.157 setting value	Description
0 (initial value)	Output immediately.
0.1 to 25	Output after the set time (s).
9999	Not output.

- The OL signal is also output during the regeneration avoidance operation ("OLV" display (overvoltage stall)).

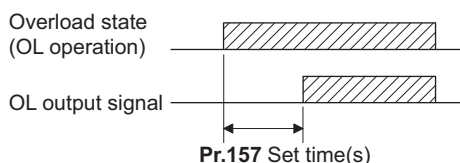
**NOTE**

- Changing the terminal assignment using **Pr.190 to Pr.196 (Output terminal function selection)** may affect the other functions. Set parameters after confirming the function of each terminal.

◀ Parameters referred to ▶

Pr.22 Stall prevention operation level [page 195](#)

Pr.178 to Pr.182 and Pr.185 to Pr.189 (Input terminal function selection) [page 252](#)

Pr.190 to Pr.196 (Output terminal function selection) [page 226](#)

Pr.865 Low speed detection [page 234](#)

5.3 Performing high-accuracy, fast-response control (gain adjustment)

PM

Gain adjustment is useful for achieving optimum machine performance or improving unfavorable conditions, such as vibration and acoustic noise during operation with high load inertia or gear backlash.

Pr.	Name	Initial value	Setting range	Description
820 G211	Speed control P gain	25%	0% to 1000%	The proportional gain during speed control is set. (Setting this parameter higher improves the trackability for speed command changes. It also reduces the speed fluctuation caused by external disturbance.)
821 G212	Speed control integral time	0.333 s	0 to 20 s	The integral time during speed control is set. (Setting this parameter lower shortens the return time to the original speed when the speed fluctuates due to external disturbance.)
824 G213	Torque control P gain (current loop proportional gain)	50	0% to 500%	Set the current loop proportional gain.
825 G214	Torque control integral time (current loop integral time)	20	0 to 500 ms	Set the current loop integral time.

◆ Speed control gain adjustment (Pr.820, Pr.821)

- The speed control gain can be adjusted for the conditions such as abnormal machine vibration, acoustic noise, slow response, and overshoot.
- Setting 25% (initial value) in **Pr.820 Speed control P gain** is equivalent to 50 rad/s (speed response of a single motor). Setting this parameter higher speeds up the response, but setting this too high causes vibration and acoustic noise.
- Setting **Pr.821 Speed control integral time** lower shortens the return time to the original speed during speed fluctuation, but setting it too low causes overshoot.

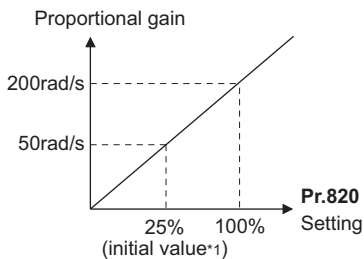

*1 Performing PM parameter initialization changes the settings. (Refer to page 77.)

- Actual speed gain is calculated as follows when load inertia is applied.

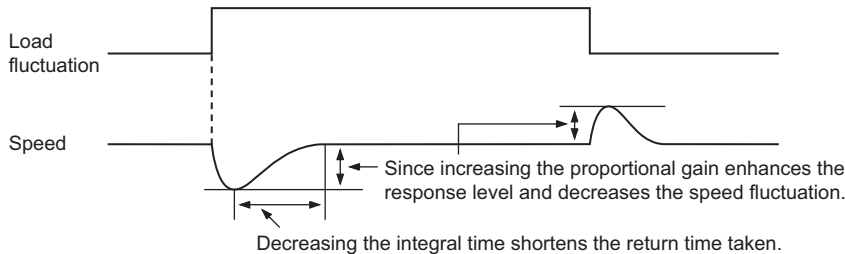

$$\text{Actual speed gain} = \text{Speed gain of a single motor} \times \frac{JM}{JM+JL}$$

JM: Motor inertia
JL: Load inertia converted as the motor axis inertia

◆ Adjustment procedure (Pr.820, Pr.821)

1. Change the **Pr.820** setting while checking the conditions.
2. If it cannot be adjusted well, change the **Pr.821** setting, and perform step 1 again.

No.	Movement / condition	Adjustment method
1	Load inertia is too high.	Set Pr.820 and Pr.821 higher.
		Pr.820 If acceleration is slow, set about 80% to 90% of the maximum value without any vibration/ acoustic noise while increasing the setting value by 10%.
		Pr.821 If overshoots occur, set about 80% to 90% of the maximum value without overshooting while increasing the setting value by twice.
2	Vibration or acoustic noise are generated from machines.	Set Pr.820 lower and Pr.821 higher.
		Pr.820 Set about 80% to 90% of the maximum value without any vibration/noise while decreasing the setting value by 10%.
		Pr.821 If overshoots occur, set about 80% to 90% of the maximum value without overshooting while increasing the setting value by twice.
3	Response is slow.	Set Pr.820 higher.
		Pr.820 If acceleration is slow, set about 80% to 90% of the maximum value without any vibration/ acoustic noise while increasing the setting value by 5%.
4	Return time (response time) is long.	Set Pr.821 lower.
		Set about 80% to 90% of the maximum value without overshooting or unstable movements while decreasing the setting value of Pr.821 by half.
5	Overshoots or unstable movements occur.	Set Pr.821 higher.
		Set about 80% to 90% of the maximum value without overshooting or unstable movements while increasing the setting value of Pr.821 by twice.

◆ Current loop proportional (P) gain adjustment (Pr.824)

- Set the current loop proportional gain.
- The 100% current loop proportional gain is equivalent to 1000 rad/s under PM sensorless vector control.
- For ordinary adjustment, try to set within the range of 50% to 500%.
- If the setting value is large, changes in current command can be followed well and current fluctuation relative to external disturbance is smaller. If the setting value is however too large, it becomes unstable and high frequency torque pulse is produced.

◆ Current loop integral time adjustment (Pr.825)

- Set the current loop integral time.
- Torque response increases if set small; current however becomes unstable if set too small.
- If the setting value is small, it produces current fluctuation toward disturbance, decreasing time until it returns to original current value.

◆ Adjustment procedure (Pr.824, Pr.825)

Adjust if any of phenomena such as unusual vibration, noise, current or overcurrent is produced by the motor or machinery.

1. Change the **Pr.824** setting while checking the conditions.
2. If it cannot be adjusted well, change the **Pr.825** setting, and perform step 1 again.

Adjustment method	
Set Pr.824 lower and Pr.825 longer. First, lower Pr.824 and then check if there is still any abnormal vibration, noise or current from the motor. If it still requires improvement, make Pr.825 longer.	
Pr.824	Lower the setting by 10% each time and set a value that is approximately 80% to 90% of the setting immediately before the abnormal noise or current improves. If set too low, current ripple is produced and produces a sound from the motor that synchronizes with it.
Pr.825	Lengthen the current setting by doubling it each time and set a value that is approximately 80% to 90% of the setting value, immediately before abnormal noise or current is improved. If set too long, current ripple is produced and produces a sound from the motor that synchronizes with it.

◆ When using a multi-pole motor (8 poles or more)

- If the motor inertia is known, set **Pr.707 Motor inertia (integer)** and **Pr.724 Motor inertia (exponent)**. (Refer to [page 274](#).)
- Adjust **Pr.820 Speed control P gain** and **Pr.824 Torque control P gain (current loop proportional gain)** to suit the motor, by referring to the following methods.
- Setting **Pr.820** higher speeds up the response, but setting this too high causes vibration and acoustic noise.
- Setting **Pr.824** too low causes current ripple, and a noise synchronous with this will be emitted from the motor.
- Adjustment method:

No.	Movement / condition	Adjustment method
1	Motor rotation speed in the low-speed range is unstable.	Pr.820 Speed control P gain must be set higher according to the motor inertia. For multi-pole motors, because the inertia of the motor itself tends to be large, first perform broad adjustment to improve the unstable movements, and then perform fine adjustment by referring to the response level based on this setting.
2	Rotation speed trackability is poor.	Set Pr.820 Speed control P gain higher. Raise the setting by 10% and set a value that approximately 80% to 90% of the setting right before vibration/noise starts occurring. If it cannot be adjusted well, double Pr.821 Speed control integral time and perform the adjustment of Pr.820 again.
3	Large fluctuation of the rotation speed relative to load fluctuation.	
4	Unusual vibration, noise and overcurrent of the motor or machine occurs.	Set Pr.824 Torque control P gain (current loop proportional gain) lower. Lower the setting by 10% and set a value that is approximately 80% to 90% of the setting immediately before the condition improves.

5.4 Adjustment when the motor wiring length is long

PM

Adjust the setting if an unstable movement such as uneven rotation or an error occurs when the motor wiring length is long or when the high-response operation is set for the control gain.

Pr.	Name	Initial value	Setting range	Description
643 E386	Voltage compensation amount setting	9999	0% to 150%	Set this parameter according to the motor wiring length.
			9999	100%

- Set **Pr.643** according to the motor wiring length, referring to the following table as a reference.

Motor wiring length	Less than 10 m	10 to 15 m	15 to 20 m	20 to 25 m	25 to 30 m
Reference setting value of Pr.643 ^{*1}	9999	85%	75%	65%	60%

*1 Differs depending on the cross section area, type, or laying of cable.

- If an unstable movement or an error persists, adjust the setting by decreasing the setting value by 5% to about 50%, as a reference.
- If an unstable movement or an error persists after the setting value is decreased to less than 50%, it may be caused by interference with the machines due to high responsivity of the motor. After setting **Pr.643** to the reference value, adjust the setting by decreasing the response level of the control gain using **Pr.820 Speed control P gain** and **Pr.821 Speed control integral time**

5.5 Troubleshooting in the speed control

PM

No.	Condition	Possible cause	Countermeasure
1	Motor does not run at the correct speed. (Command speed and actual speed differ.)	Speed command from the controller is different from the actual speed. The speed command is affected by noise.	<ul style="list-style-type: none"> • Check that the speed command sent from the controller is correct. (Take EMC measures.) • Lower the setting of Pr.72 PWM frequency selection.
		The command speed and the speed recognized by the inverter are different.	<ul style="list-style-type: none"> • Adjust the bias and gain (Pr.125, Pr.126, C2 (Pr.902) to C7 (Pr.905)) of the speed command again.
2	The speed does not accelerate to the command speed.	Torque shortage. The torque limit is operating.	<ul style="list-style-type: none"> • Raise the torque limit. (Refer to the torque limit for speed control on page 87.) • Increase the capacity.
		Only P (proportional) control is performed.	<ul style="list-style-type: none"> • Speed deviation occurs under P (proportional) control when the load is heavy. Select PI control.
3	Motor speed fluctuates.	Speed command varies.	<ul style="list-style-type: none"> • Check that the speed command sent from the controller is correct. (Take EMC measures.) • Set Pr.72 lower.
		Torque shortage.	<ul style="list-style-type: none"> • Raise the torque limit. (Refer to the torque limit for speed control on page 87.)
		Speed control gain is not suitable for the machine. (Resonance occurs.)	<ul style="list-style-type: none"> • Adjust Pr.820 Speed control P gain and Pr.821 Speed control integral time.
4	Hunting (vibration or acoustic noise) occurs in the motor or the machine.	Speed control gain is too high.	<ul style="list-style-type: none"> • Set Pr.820 lower and Pr.821 higher.
		Torque control gain is too high.	<ul style="list-style-type: none"> • Set Pr.824 Torque control P gain (current loop proportional gain) lower.
		Motor wiring is incorrect.	<ul style="list-style-type: none"> • Check the wiring.
5	Acceleration/ deceleration time is different from the setting.	Torque shortage.	<ul style="list-style-type: none"> • Raise the torque limit. (Refer to the torque limit for speed control on page 87.)
		Load inertia is too high.	<ul style="list-style-type: none"> • Set acceleration/deceleration time suitable for the load.
6	Machine movement is unstable.	Speed control gain is not suitable for the machine.	<ul style="list-style-type: none"> • Adjust Pr.820 and Pr.821.
		Response is slow because of the inverter's acceleration/ deceleration time setting.	<ul style="list-style-type: none"> • Set the optimum acceleration/deceleration time.
7	Rotation ripple occurs during the low-speed operation.	High carrier frequency is affecting the motor rotation.	<ul style="list-style-type: none"> • Set Pr.72 lower.
		Speed control gain is too low.	<ul style="list-style-type: none"> • Set Pr.820 higher.
8	Torque is insufficient in the low-speed range.	Torque ripples or uneven rotation occur.	<ul style="list-style-type: none"> • Adjust the Pr.820 setting.

«Parameters referred to»

Pr.72 PWM frequency selection  [page 120](#)

Pr.80 Motor capacity, Pr.81 Number of motor poles  [page 72](#)

Pr.125 Terminal 2 frequency setting gain frequency, Pr.126 Terminal 4 frequency setting gain frequency  [page 248](#)

Pr.824 Torque control P gain (current loop proportional gain)  [page 90](#)

6 (E) Environment Setting Parameters

Purpose	Parameter to set			Refer to page
To set the time	Clock	P.E020 to P.E022	Pr.1006 to Pr.1008	96
To set a limit for the reset function. To shut off output if the operation panel disconnects. To force deceleration to stop on the operation panel.	Reset selection/ disconnected PU detection/PU stop selection	P.E100 to P.E102	Pr.75	97
To select the display language of the parameter unit	PU display language selection	P.E103	Pr.145	100
To control the buzzer of the parameter unit or LCD operation panel	PU buzzer control	P.E104	Pr.990	101
To adjust the LCD contrast of the parameter unit or LCD operation panel	PU contrast adjustment	P.E105	Pr.991	102
To turn OFF the operation panel when not using it for a certain period of time	Display-off setting	P.E106	Pr.1048	103
To set the frequency automatically. To disable the operation panel.	Operation panel operation selection	P.E200	Pr.161	104
To change the frequency change increments which changes when using the setting dial of the operation panel	Frequency change increment amount setting	P.E201	Pr.295	106
To determine which direction the motor rotates when the RUN key on the operation panel is pressed	RUN key rotation direction selection	P.E202	Pr.40	107
To use the regeneration unit to increase the motor braking torque	Regenerative brake selection	P.E300, P.G107	Pr.30, Pr.70	340
To change the overload current rating specification	Multiple rating setting	P.E301	Pr.570	108
To reduce the unstable movements or the error occurrence	Voltage compensation amount setting	P.E386	Pr.643	93
To prevent parameter rewriting	Parameter write disable selection	P.E400	Pr.77	109
To restrict parameters with a password	Password	P.E410, P.E411	Pr.296, Pr.297	111
To use parameters freely	Free parameter	P.E420, P.E421	Pr.888, Pr.889	114
To change parameter settings for a PM motor as a batch	PM parameter initialization	P.E430	Pr.998	77
To set multiple parameters by batch	Automatic parameter setting	P.E431	Pr.999	115
To display the required parameters	Applicable parameter display and user group function	P.E440 to P.E443	Pr.160, Pr.172 to Pr.174	117
To reduce the motor noise and EMI	PWM carrier frequency changing	P.E600 to P.E602	Pr.72, Pr.240, Pr.260	120
To understand the maintenance time of inverter parts and peripheral devices	Inverter parts life display	P.E700 to P.E706, P.E708	Pr.255 to Pr.259, Pr.506, Pr.507, Pr.509	122
	Maintenance output function	P.E710, P.E711	Pr.503, Pr.504	126
	Current average monitor	P.E720 to P.E722	Pr.555 to Pr.557	127

6.1 Clock

The time can be set. The time can only be updated while the inverter power is ON.

The real time clock function is enabled using an optional LCD operation panel (FR-LU08).

Pr.	Name	Initial value	Setting range	Description
1006 E020	Clock (year)	2000 (year)	2000 to 2099	Set the year.
1007 E021	Clock (month, day)	101 (January 1)	101 to 131, 201 to 228, (229), 301 to 331, 401 to 430, 501 to 531, 601 to 630, 701 to 731, 801 to 831, 901 to 930, 1001 to 1031, 1101 to 1130, 1201 to 1231	Set the month and day. 1000's and 100's digits: January to December, 10's and 1's digits: 1 to the last day of the month (28, 29, 30, or 31). For December 31, set "1231".
1008 E022	Clock (hour, minute)	0 (00:00)	0 to 59, 100 to 159, 200 to 259, 300 to 359, 400 to 459, 500 to 559, 600 to 659, 700 to 759, 800 to 859, 900 to 959, 1000 to 1059, 1100 to 1159, 1200 to 1259, 1300 to 1359, 1400 to 1459, 1500 to 1559, 1600 to 1659, 1700 to 1759, 1800 to 1859, 1900 to 1959, 2000 to 2059, 2100 to 2159, 2200 to 2259, 2300 to 2359	Set the hour and minute using the 24-hour clock. 1000's and 100's digits: 0 to 23 hours, 10's and 1's digits: 0 to 59 minutes. For 23:59, set "2359".

◆ Simple clock function

- When the current year, month, day, hour and minute are set in the parameters above, the inverter internal clock starts ticking. The set date and time can be checked by reading the parameters.

NOTE

- The time data of the internal clock is saved in the inverter's EEPROM every 10 minutes.

◆ Real time clock function

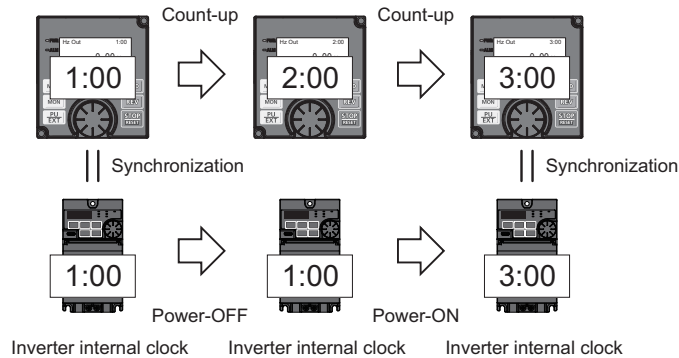

- When the FR-LU08 is connected to the inverter, the internal clock of the inverter can be synchronized with the clock in the FR-LU08 (Real time clock function). When a battery (CR1216) is installed, the time counter of the FR-LU08 continues even if the main power of the inverter is turned OFF. (The inverter internal clock stops running when the inverter power is turned OFF.)
- To adjust the clock in the FR-LU08, set **Pr.1006 to Pr.1008** on the FR-LU08.

NOTE

- Time synchronization between the inverter internal clock and the clock in the FR-LU08 is performed every one minute.
- If the FR-LU08 clock is reset due to dead battery for example, the data in the inverter internal clock is used.

6.2 Reset selection/disconnected PU detection/PU stop selection

The reset input acceptance, disconnected PU connector detection function, and PU stop function can be selected.

Pr.	Name	Initial value	Setting range	Description
75	Reset selection/ disconnected PU detection/PU stop selection	14	0 to 3, 14 to 17	In the initial setting, the reset command input is always enabled, the inverter operation continues even when PU is disconnected, and the operation can be stopped on the PU.
E100	Reset selection	0	0	Reset input is always enabled.
			1	Reset input is enabled only when the protective function is activated.
E101	Disconnected PU detection	0	0	Operation continues even when the PU is disconnected.
			1	The inverter output is shut off when the PU is disconnected.
E102	PU stop selection	1	0	The inverter decelerates to stop when the STOP/RESET key on the PU is pressed in PU operation mode. (The PU stop function is disabled.)
			1	The inverter decelerates to stop when the STOP/RESET key on the PU is pressed in any operation mode of the PU, external, or Network. (The PU stop function is enabled.)

6

The parameters above do not return to their initial values even if Parameter clear / All parameter clear is executed.

Pr.75 setting	Reset input	Operation after PU disconnection is detected	PU stop function
0	Always enabled.	Operation continues.	Disabled
1	When the protective function is activated.	Operation continues.	Disabled
2	Always enabled.	Inverter output shutoff	Disabled
3	When the protective function is activated.	Inverter output shutoff	Disabled
14	Always enabled.	Operation continues.	Enabled
15	When the protective function is activated.	Operation continues.	Enabled
16	Always enabled.	Inverter output shutoff	Enabled
17	When the protective function is activated.	Inverter output shutoff	Enabled

◆ Reset selection (P.E100)

- While **P.E100** = "1", or **Pr.75** = "1, 3, 15, or 17", the reset command input is enabled (using the RES signal or through communication) only when the protective function is activated.

NOTE

- When the RES signal is input during operation, the motor coasts since the inverter being reset shuts off the output. Also, the cumulative values of electronic thermal O/L relay and regenerative brake duty are cleared.
- When "reset input always enabled" is selected, the STOP/RESET key on the PU is enabled only when the protective function is activated.
- Reset by the RES signal assigned to a communication virtual terminal is disabled except when the protective function is activated.
- During emergency drive operation, reset input is always enabled regardless of the reset selection setting.

◆ Disconnected PU detection (P.E101)

- When the inverter detects that the PU connector is disconnected from the inverter for one second or more while **P.E101** = "1" or **Pr.75** = "2, 3, 16, or 17", the PU disconnection ("E.PUE") indication is displayed and the inverter output is shut off.

NOTE

- When the PU has been disconnected before power-ON, the output is not shut off.
- To restart the inverter operation, confirm that the PU is connected before reset.
- When the inverter detects that the PU is disconnected during PU JOG operation while **P.E101** or **Pr.75** is set to continue the inverter operation even when the PU is disconnected, the inverter decelerates the motor to stop.
- During RS-485 communication operation via the PU connector, the Reset selection function and the PU stop selection function are enabled but the Disconnected PU detection function is disabled. (The communication is checked according to **Pr.122 RS-485 communication check time interval**.)

◆ PU stop selection (P.E102)

- The inverter operation can be stopped in any operation mode (PU, External, or Network) by pressing the STOP/RESET key on the PU (operation panel / parameter unit).
- When the inverter is stopped by the PU stop function, "PS" is displayed on the operation panel. However, the Fault signal is not output.
- When **P.E102** = "0", or **Pr.75** = "0 to 3", only the inverter in the PU operation mode decelerates to stop by pressing the STOP/RESET key.

NOTE

- In the PU operation mode, the inverter decelerates to stop (PU stop function) also when the start command is input by a command source device (set in **Pr.551**) and then the STOP/RESET key is pressed on a PU which is not the command source.
(Example) When the operation panel is the command source and the stop command is input via USB (FR Configurator2), the PU stop function is activated.

◆ How to restart the inverter which has been stopped in the External operation mode by using the STOP/RESET key on the PU ("PS" (PU stop) warning reset method)

- PU stop release method for operation panel

1. After completion of deceleration stop, turn OFF the STF or STR signal.
2. Press the HAND/AUTO key three times. (The PS warning is reset.)
(When **Pr.79 Operation mode selection** = "0 (initial value) or 6")
When **Pr.79** = "2, 3, or 7", the PU stop warning can be cleared with one keystroke.

- PU stop release method for parameter unit (FR-PU07)

1. After completion of deceleration stop, turn OFF the STF or STR signal.
2. Press the EXT key. (The PS warning is reset.)

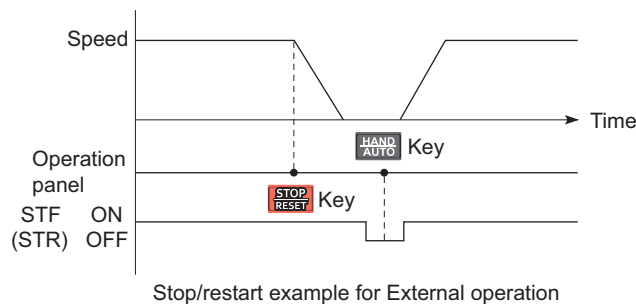

- The inverter can be restarted by performing the reset operation (by turning OFF and ON the power or inputting the RES signal).

NOTE

- Even when **Pr.250 Stop selection** ≠ "9999" and coasting stop is selected, using the PU stop function in the External operation mode does not provide coasting stop but deceleration stop.

⚠ CAUTION

- Do not perform a reset while a start signal is being input. Doing so will cause a sudden start of the motor, which is dangerous.

Parameters referred to

Pr.79 Operation mode selection [page 142](#)

Pr.250 Stop selection [page 338](#)

Pr.551 PU mode operation command source selection [page 153](#)

6.3 PU display language selection

The display language of the parameter unit (FR-PU07) can be selected.

Pr.	Name	Initial value	Setting range	Description
145 E103	PU display language selection	—	0	Japanese
			1	English
			2	German
			3	French
			4	Spanish
			5	Italian
			6	Swedish
			7	Finnish

6.4 Buzzer control

The key sound and buzzer of the LCD operation panel (FR-LU08) or parameter unit (FR-PU07) can be turned ON/OFF.

Pr.	Name	Initial value	Setting range	Description
990 E104	PU buzzer control	1	0	Turns the key sound and buzzer OFF.
			1	Turns the key sound and buzzer ON.

NOTE

- When the buzzer is set to ON, a warning sound will be audible when a fault occurs.

6.5 PU contrast adjustment

Contrast of the LCD display on the LCD operation panel (FR-LU08) or the parameter unit (FR-PU07) can be adjusted. Decreasing the setting value lowers the contrast.

Pr.	Name	Initial value	Setting range	Description
991 E105	PU contrast adjustment	58	0 to 63	0: Low → 63: High

This parameter can be selected from among simple mode parameters only when the LCD operation panel (FR-LU08) or the parameter unit (FR-PU07) is connected to the inverter.

6.6 Display-off setting

The LED display of the operation panel can be turned OFF when the operation panel has not been used for a certain period of time.

Pr.	Name	Initial value	Setting range	Description
1048 E106	Display-off waiting time	0	0	Display-off setting is disabled.
			1 to 60 min	Set time until the LED of the operation panel is turned OFF.
			100 to 160	Set time until the decimal places are hidden from the monitor display (Pr.1048 - 100 min).

- When **Pr.1048** = "1 to 60" and the operation panel has not been operated for the time set in **Pr.1048**, the LEDs on the operation panel (Hz, A, HAND, AUTO, NET, PRM, PM, and RUN) turns OFF.
- When **Pr.1048** = "100 to 160" and the inverter has stopped with no operation panel operation for the time set in **Pr.1048** minus 100 minutes, the monitor will hide the decimal places.
- In the display-off state, the MON LED blinks slowly.
- The display-off timer resets to zero at inverter power ON/OFF, inverter reset, or when parameter settings are changed by methods other than the operation panel.
- The triggers for display-on are as follows:
 - Operation of the operation panel
 - Occurrence of a warning, alarm, or fault
 - Power-ON/OFF of the inverter, or the inverter reset
 - Status other than inverter stop (when **Pr.1048** = "100 to 160")
 - Mode other than monitor mode (when **Pr.1048** = "100 to 160")
 - Monitoring cumulative energization time, actual operation time, cumulative energy, or cumulative energy saving (when **Pr.1048** = "100 to 160")

6.7 Automatic frequency setting / key lock operation selection

Turning the setting dial on the operation panel enables frequency setting without pressing the SET key.
The key operation of the operation panel can be disabled.

Pr.	Name	Initial value	Setting range	Description	
161 E200	Frequency setting/key lock operation selection	0	0	Automatic frequency setting disabled	Key lock function disabled.
			1	Automatic frequency setting enabled	
			10	Automatic frequency setting disabled	Key lock function enabled.
			11	Automatic frequency setting enabled	

◆ Automatic frequency setting (Pr.161 = "1 or 11")

- To set the frequency using the operation panel when Pr.161 = "0 (initial value) or 10", change the frequency value using the setting dial, and press the SET key to confirm the setting (the value is stored in the RAM and EEPROM).
- When Pr.161 = "1 or 11", the automatic frequency setting is enabled. After the frequency value is changed using the setting dial, the value indicated is stored in the RAM. If the frequency value has not been changed for 10 seconds, the value is stored in the EEPROM.

When the automatic frequency setting is disabled (Pr.161 = "0 (initial value) or 10")

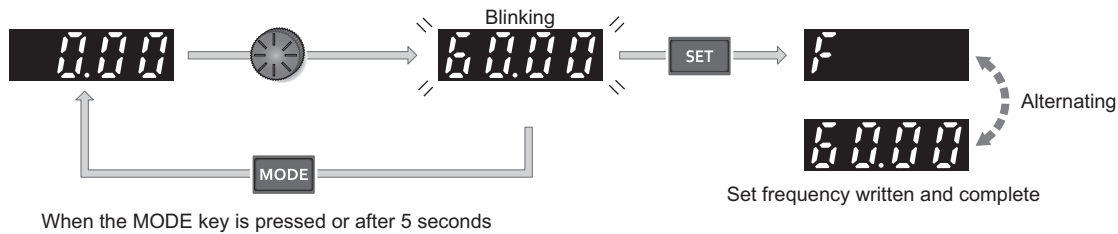

When the automatic frequency setting is enabled (Pr.161 = "1 or 11")

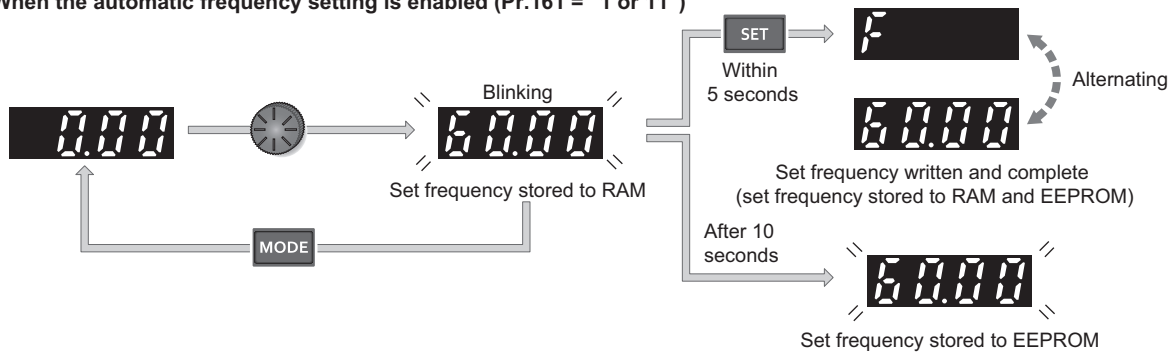

NOTE

- If the operation panel does not have the operation command source (Pr.551 = "2, 3, or 9999" (with USB and/or PU connection)), the frequency cannot be set using the operation panel.
- If the operation mode is changed to one in which the inverter does not operate according to the frequency set on the operation panel after the frequency value is stored in the RAM but before it is stored in the EEPROM, the value is not stored in the EEPROM.
- If the power is OFF or the inverter is reset after the frequency value is stored in the RAM but before it is stored in the EEPROM, the value is not stored in the EEPROM.
- When setting the frequency by turning the setting dial, the frequency goes up to the set value of Pr.1 Maximum frequency. Be aware of what frequency Pr.1 is set to, and adjust the setting of Pr.1 according to the application.

◆ Disabling the setting dial and keys on the operation panel (by holding down the MODE key for 2 seconds)

- Operation using the setting dial and keys of the operation panel can be disabled to prevent parameter changes, unexpected starts or frequency changes.
- Set **Pr.161** to "10 or 11" and then press the MODE key for two seconds to disable setting dial or key operations.
- When the setting dial and key operation are disabled, "HOLD" appears on the operation panel. If setting dial or key operation is attempted while dial and key operations are disabled, "HOLD" appears. (After no setting dial or key operation for 2 seconds, the display returns to the monitoring screen.)
- To enable the setting dial and key operation again, press the MODE key for 2 seconds.

NOTE

- Even if setting dial and key operations are disabled, the monitor indicator and STOP/RESET key are enabled.
- The PU stop warning cannot be reset by using keys while the key lock function is enabled.

« Parameters referred to »»

Pr.1 Maximum frequency  [page 191](#)

6.8 Frequency change increment amount setting

When setting the set frequency with the setting dial of the operation panel, the frequency changes in 0.01 Hz increments in the initial status. Setting this parameter to increase the frequency increment amount that changes when the setting dial is rotated can improve usability.

Pr.	Name	Initial value	Setting range	Description
295 E201	Frequency change increment amount setting	0	0	Function disabled
			0.01	The minimum change width when the set frequency is changed with the setting dial can be set.
			0.10	
			1.00	
			10.00	

◆ Basic operation

- When **Pr.295** ≠ "0", the minimum increment when the set frequency is changed with the setting dial can be set. For example, when **Pr.295** = 1.00 Hz, one click (one dial gauge) of the setting dial changes the frequency in increments of 1.00 Hz, such as 1.00 Hz → 2.00 Hz → 3.00 Hz.

When **Pr.295** = "1.00"



NOTE

- When machine speed display is selected in **Pr.53 Frequency / rotation speed unit switchover**, the minimum increments of change are determined by **Pr.295** as well. Note that the setting value may differ as speed setting changes the set machine speed and converts it to the speed display again.
- For **Pr.295**, the increments are not displayed.
- The **Pr.295** setting is enabled only for the changes to the set frequency. It does not apply to the settings of other parameters related to frequency.
- When 10 is set, the frequency setting changes in 10 Hz increments. Be cautious of excessive speed (when Automatic frequency setting enabled).

Parameters referred to

Pr.53 Frequency / rotation speed unit switchover [page 206](#)

6.9 RUN key rotation direction selection

The rotation direction of the motor when the RUN key on the operation panel is pressed can be selected.

Pr.	Name	Initial value	Setting range	Description
40 E202	RUN key rotation direction selection	0	0	Forward rotation
			1	Reverse rotation

6.10 Multiple rating setting

Two rating types of different rated current and permissible load can be selected. The optimal inverter rating can be selected according to the application, enabling equipment to be downsized.

Pr.	Name	Initial value	Setting range	Description (overload current rating, surrounding air temperature)
570 E301 ^{*1}	Multiple rating setting	2	0	SLD rating. 110% for 60 seconds, 120% for 3 seconds (inverse-time characteristics) at surrounding air temperature of 40°C.
			2	ND rating. 150% for 60 seconds, 200% for 0.5 second (inverse-time characteristics) at surrounding air temperature of 50°C.

*1 Available for the three-phase power input model only.

◆ Changing the parameter initial values and setting ranges

- When the Pr.570 setting is changed, initial values of the following parameters will be changed according to each rating by performing an inverter reset and All parameter clear.

Pr.	Name	Pr.570 setting		Refer to page
		0	2 (initial value)	
0	Torque boost	*1	*1	327
7	Acceleration time	*1	*1	130
8	Deceleration time	*1	*1	130
9	Electronic thermal O/L relay	SLD rated current ^{*2}	ND rated current ^{*2*3}	166
12	DC injection brake operation voltage	*1	*1	335
22	Stall prevention operation level	110%	150%	87, 195
44	Second acceleration/deceleration time	*1	*1	130
56	Current monitoring reference	SLD rated current ^{*2}	ND rated current ^{*2}	216
150	Output current detection level	110%	150%	237
165	Stall prevention operation level for restart	110%	150%	307
557	Current average value monitor signal output reference current	SLD rated current ^{*2}	ND rated current ^{*2}	127
874	OLT level setting	110%	150%	87
893	Energy saving monitor reference (motor capacity)	Applicable motor capacity (SLD) ^{*2}	Applicable motor capacity (ND) ^{*2}	219

*1 Initial values differ depending on the rating as follows.

FR-D820-[]	FR-D840-[]	Pr.0 (%)		Pr.7, Pr.8, Pr.44 (s)		Pr.12 (%)	
		SLD	ND	SLD	ND	SLD	ND
0.1K-008	—	6	6	5	5	6	6
0.2K-014	—	6	6	5	5	4	6
0.4K-025	0.4K-012	6	6	5	5	4	4
0.75K-042	0.75K-022	4	6	5	5	4	4
1.5K-070	1.5K-037	4	4	5	5	4	4
2.2K-100	2.2K-050	4	4	5	5	4	4
3.7K-165	3.7K-081	3	4	10	5	4	4
5.5K-238	5.5K-120	3	3	10	10	4	4
7.5K-318	7.5K-163	2	3	15	10	2	4
11K-450	11K-230	2	2	15	15	2	2
15K-580	15K-295	2	2	15	15	2	2

*2 The rated current and applicable motor capacity values differ depending on the inverter capacity. Refer to the inverter rated specifications in the Instruction Manual (Connection).

*3 The initial value for the FR-D820-0.75K-042 or lower and the FR-D840-0.75K-022 or lower is set to the 85% of the inverter rated current.

6.11 Parameter write selection

Whether or not to enable the writing to various parameters can be selected. Use this function to prevent parameter values from being rewritten by misoperation.

Pr.	Name	Initial value	Setting range	Description
77 E400	Parameter write selection	0	0	Writing is enabled only during stop.
			1	Writing is disabled.
			2	Writing is enabled in any operation mode regardless of the operation status.

- Pr.77 can be set at any time regardless of the operation mode or operation status. (Setting through communication is unavailable.)

◆ Parameter write enabled only during stop (Pr.77 = "0 (initial value)")

- Parameters can be written only during a stop in the PU operation mode.
- The following parameters can always be written regardless of the operation mode or operation status.

Pr.	Name
4 to 6	(Multi-speed setting high-speed, middle-speed, low-speed)
22	Stall prevention operation level
24 to 27	(Multi-speed setting speed 4 to speed 7)
52	Operation panel main monitor selection
55	Frequency monitoring reference
56	Current monitoring reference
72 ^{*1}	PWM frequency selection
75	Reset selection/disconnected PU detection/PU stop selection
77	Parameter write selection
79 ^{*2}	Operation mode selection
129	PID proportional band
130	PID integral time
133	PID action set point
134	PID differential time
158	AM terminal function selection
160	User group read selection
232 to 239	(Multi-speed setting speed 8 to speed 15)
240 ^{*1}	Soft-PWM operation selection
241	Analog input display unit switchover
268	Monitor decimal digits selection
295	Frequency change increment amount setting
296, 297	(Password setting)
340 ^{*2}	Communication startup mode selection
496	(Remote output)

Pr.	Name
533	Vibration suppression response adjustment
551 ^{*2}	PU mode operation command source selection
555 to 557	(Current average value monitoring)
663	Control circuit temperature signal output level
759	PID unit selection
774 to 776	(Operation panel monitor item selection)
866	Torque monitoring reference
888, 889	(Free parameter)
891 to 899	(Energy saving monitoring)
C1 (901)	AM terminal calibration
990	PU buzzer control
991	PU contrast adjustment
992	Operation panel setting dial push monitor selection
997	Fault initiation
998 ^{*2}	PM parameter initialization
999 ^{*2}	Automatic parameter setting
1006	Clock (year)
1007	Clock (month, day)
1008	Clock (hour, minute)
1020	Trace operation selection
1048	Display-off waiting time
1200	AM output offset calibration
1480 to 1485	(Load characteristics fault)

*1 Writing during operation is enabled in PU operation mode, but disabled in External operation mode.

*2 Writing during operation is disabled. To change the parameter setting value, stop the operation.

◆ Parameter write disabled (Pr.77 = "1")

- Parameter write, Parameter clear, and All parameter clear are disabled. (Parameter read is enabled.)
- The following parameters can be written even if Pr.77 = "1".

Pr.	Name
22	Stall prevention operation level
75	Reset selection/disconnected PU detection/PU stop selection
77	Parameter write selection
79*1	Operation mode selection
160	User group read selection

Pr.	Name
296	Password lock level
297	Password lock/unlock
496	(Remote output)
997	Fault initiation
1020	Trace operation selection

*1 Writing during operation is disabled. To change the parameter setting value, stop the operation.

◆ Parameter write enabled during operation (Pr.77 = "2")

- Parameters can always be written.
- The following parameters cannot be written during operation if Pr.77 = "2". To change the parameter setting value, stop the operation.

Pr.	Name
23	Stall prevention operation level compensation factor at double speed
40	RUN key rotation direction selection
48	Second stall prevention operation level
60	Energy saving control selection
66	Stall prevention operation reduction starting frequency
71	Applied motor
79	Operation mode selection
80	Motor capacity
81	Number of motor poles
82	Motor excitation current
83	Rated motor voltage
84	Rated motor frequency
90 to 94	(Motor constant)
96	Auto tuning setting/status
178 to 182, 185 to 196	(Input/output terminal function selection)
261	Power failure stop selection
289	Inverter output terminal filter
291	Pulse train input selection
298	Frequency search gain

Pr.	Name
450	Second applied motor
507	Display/reset ABC relay contact life
532, 534, 535	(Vibration suppression control)
541	Frequency command sign selection
561	PTC thermistor protection level
570	Multiple rating setting
631	Inverter output fault detection enable/disable selection
643	Voltage compensation amount setting
660 to 662	(Increased magnetic excitation deceleration)
673	SF-PR slip amount adjustment operation selection
699	Input terminal filter
702	Maximum motor frequency
706, 707, 711, 712, 717, 721, 724, 725, 1412	(PM motor tuning)
795	DC injection brake operation current level
800	Control method selection
859	Torque current/Rated PM motor current
998	PM parameter initialization
999	Automatic parameter setting
1002	Lq tuning target current adjustment coefficient

6.12 Password

Registering a 4-digit password can restrict access to parameters (reading/writing).

Pr.	Name	Initial value	Setting range	Description
296 E410	Password lock level	9999	1 to 6, 99, 101 to 106, 199	Select restriction level of parameter reading/writing when a password is registered.
			9999	No password protection
297 E411	Password lock/unlock	9999	1000 to 9998	Input a 4-digit password to lock parameters, or input the valid password to unlock the locked parameters.
			(0 to 5) ^{*1}	Number of failed password attempts (read only, displayed after any of "101 to 106, or 199" is set in Pr.296 and a password to lock parameters is input).
			9999 ^{*1}	No password protection

These parameters can be set when **Pr.160 User group read selection** = "0". However, when **Pr.296** ≠ "9999" (password lock is set), **Pr.297** can always be set, regardless of the setting in **Pr.160**.

^{*1} Although "0 or 9999" can be input in **Pr.297**, the value is invalid. (The display cannot be changed.)

◆ Parameter reading/writing restriction level (Pr.296)

- The access (reading/writing) restriction level to parameters in the PU operation mode or NET operation mode can be selected with **Pr.296**.

Pr.296 setting	PU operation mode operation command ^{*3}		NET operation mode operation command ^{*4}	
	Read ^{*1}	Write ^{*2}	RS-485 communication	
			Read	Write ^{*2}
9999	○	○	○	○
1, 101	○	×	○	×
2, 102	○	×	○	○
3, 103	○	○	○	×
4, 104	×	×	×	×
5, 105	×	×	○	○
6, 106	○	○	×	×
99, 199	Only the parameters registered in the user group can be read/written. (For the parameters not registered in the user group, the restriction level when "4 or 104" is set applies.) ^{*5}			

○: Enabled, ×: Disabled

^{*1} If the parameter reading is restricted by the setting of **Pr.160 User group read selection**, those parameters cannot be read even when "○" is indicated.

^{*2} If the parameter writing is restricted by the setting of **Pr.77 Parameter write selection**, those parameters cannot be written even when "○" is indicated.

^{*3} Access from the command source in the PU operation mode (the operation panel or the USB connector in the initial setting) is restricted. (For the PU operation mode command source selection, refer to [page 153](#).)

^{*4} Access from the command source in the Network operation mode (the PU connector or the RS-485 terminals in the initial setting) is restricted.

^{*5} Read/write is enabled only for the simple mode parameters registered in the user group when **Pr.160** = "9999". **Pr.296** and **Pr.297** are always read/write enabled whether registered to a user group or not.

◆ Locking parameters with a password (Pr.296, Pr.297)

- The procedure of locking parameters with a password is as follows.

1. Set the parameter reading/writing restriction level to enable the password protection. (Set a value other than "9999" in **Pr.296**.)

Pr.296 setting	Allowable number of failed password attempts	Pr.297 readout
1 to 6, 99	Unlimited	Always 0
101 to 106, 199*1	Limited to 5 times	Number of failed password attempts (0 to 5)

*1 If an invalid password is input 5 times while any of "101 to 106, or 199" is set in **Pr.296**, the locked parameters cannot be unlocked afterward even with the valid password. All parameter clear is required to reset the password. (After All parameter clear is performed, the parameters are returned to their initial values.)

2. Write a 4-digit number (1000 to 9998) to **Pr.297** as a password (writing is disabled when **Pr.296** = "9999"). After a password is set, parameters are locked and access (reading/writing) to the parameters is limited at the level set in **Pr.296** until the valid password is input to unlock the locked parameters.

NOTE

- After a password is set, the **Pr.297** readout is always any of "0 to 5".
- "LOCD" appears when a password-protected parameter is attempted to be read/written.
- Even if a password is set, the parameters which are written by the inverter, such as parameters related to the life check of inverter parts, are overwritten as needed.
- Even if a password is registered, reading/writing is enabled for **Pr.991 PU contrast adjustment** when the parameter unit (FR-PU07) is connected.

◆ Unlocking the locked parameters (Pr.296, Pr.297)

- There are two ways to unlock the locked parameters.
- Enter the password in **Pr.297**. When a valid password is input, the locked parameters can be unlocked. When an invalid password is input, an error indication appears and the parameters cannot be unlocked. If an invalid password is input 5 times while any of "101 to 106, or 199" is set in **Pr.296**, the locked parameters cannot be unlocked afterward even with the valid password (the password is locked up).
- Perform All parameter clear.

NOTE

- If the password is forgotten, it can be reset by performing All parameter clear, but the other parameters are also reset.
- All parameter clear cannot be performed during the operation.
- When using FR Configurator2 in the PU operation mode, do not set "4, 5, 99, 104, 105, or 199" (parameter read is disabled) in **Pr.296**. Doing so may cause abnormal operation.
- The means to reset the password varies according to how the reset command is sent (from the PU or through RS-485 communication).

	PU (operation panel or parameter unit)	RS-485 communication
All parameter clear	○	○
Parameter clear	×	×

○: Password reset enabled, ×: Password reset disabled

- To perform Parameter clear or All parameter clear with the parameter unit (FR-PU07), refer to the FR-PU07 Instruction Manual. (For details on the operation panel, refer to [page 14](#). For details on RS-485 communication, refer to the Instruction Manual (Communication).)

◆ Access to parameters according to the password status

Parameter		Password protection disabled / Parameters unlocked		Parameters locked	Password locked up
		Pr.296 = "9999", Pr.297 = "9999"	Pr.296 ≠ "9999", Pr.297 = "9999"	Pr.296 ≠ "9999", Pr.297 = "0 to 4" (read value)	Pr.296 = "101 to 106, 199", Pr.297 = "5" (read value)
Pr.296	Read	○ ^{*1}	○	○	○
	Write	○ ^{*1}	○ ^{*1}	×	×
Pr.297	Read	○ ^{*1}	○	○	○
	Write	×	○	○	○ ^{*3}
Parameter clear		○	○	×	×
All parameter clear		○	○	○ ^{*2}	○ ^{*2}
Parameter copy		○	○	×	×

○: Enabled, ×: Disabled

*1 Reading/writing is disabled if reading is restricted by the **Pr.160** setting. (Reading is available in the Network operation mode regardless of the **Pr.160** setting.)

*2 All parameter clear cannot be performed during the operation.

*3 Inputting a password is possible but the locked-up password cannot be unlocked or reset even with the valid password.

NOTE

- When "4, 5, 104, or 105" is set in **Pr.296** and a password is set, PU JOG frequency is not listed on the parameter unit (FR-PU07).
- When a password has been set and parameters are locked, parameter copy cannot be performed using the parameter unit.

Parameters referred to

Pr.77 Parameter write selection  [page 109](#)

Pr.160 User group read selection  [page 117](#)

Pr.551 PU mode operation command source selection  [page 153](#)

6.13 Free parameter

Any number within the setting range of 0 to 9999 can be input.

For example, these numbers can be used:

- As a unit number when multiple units are used.
- As a pattern number for each operation application when multiple units are used.
- As the year and month of introduction or inspection.

Pr.	Name	Initial value	Setting range	Description
888 E420	Free parameter 1	9999	0 to 9999	Any value can be input. The settings are retained even if the inverter power is turned OFF.
889 E421	Free parameter 2	9999	0 to 9999	

NOTE

- **Pr.888 and Pr.889** do not influence the operation of the inverter.
-

6.14 Setting multiple parameters by batch

The setting of particular parameters is changed by batch, such as communication parameters for connection with the Mitsubishi Electric human machine interface (GOT), the parameters for the rated frequency (50/60 Hz) setting, or the parameters for acceleration/deceleration time increment.

Multiple parameters are changed automatically. Users do not have to consider each parameter number (automatic parameter setting).

Pr.	Name	Initial value	Setting range	Description
999 E431	Automatic parameter setting	9999*1	10	GOT initial setting (PU connector / RS-485 terminals) "Controller Type" in GOT: FREQROL 500/700/800, SENSORLESS SERVO
			12	GOT initial setting (PU connector / RS-485 terminals) "Controller Type" in GOT: FREQROL 800 (Automatic Negotiation)
			20	Rated frequency of 50 Hz
			21	Rated frequency of 60 Hz
			9999	No action

*1 The read value is always "9999".

◆ Automatic parameter setting (Pr.999)

- Select which parameters to automatically set from the following table, and set them in **Pr.999**. Multiple parameter settings are changed automatically. Refer to [page 115](#) for the list of parameters that are changed automatically.

Pr.999 setting	Description	Operation in the automatic parameter setting mode
10	Automatically sets the communication parameters for the GOT connection with a PU connector or RS-485 terminals ("Controller Type" in GOT: FREQROL 500/700/800, SENSORLESS SERVO)	"AUTO"→"GOT"→Write "1".
12	Automatically sets the communication parameters for the GOT connection with a PU connector or RS-485 terminals "Controller Type" in GOT: FREQROL 800 (Automatic Negotiation)	"AUTO"→"GOT"→Write "2".
20	Rated frequency of 50 Hz	Sets the related parameters of the rated frequency according to the power supply frequency "AUTO"→"F50"→Write "1".
21	Rated frequency of 60 Hz	

NOTE

- If the automatic setting is performed with **Pr.999** or the automatic parameter setting mode, the settings including the changed parameter settings (changed from the initial setting) will be automatically changed. Before performing the automatic setting, confirm that changing the parameters will not cause any problem.
- "AUTO" is displayed on the operation panel also when the user group function is used (**Pr.160** = "1"). However, if **Pr.999** is not registered in the group, the automatic setting cannot be performed (write error (Er1) occurs).

◆ GOT initial setting (PU connector / RS-485 terminals) (Pr.999 = "10, 12")

Pr.	Name	Initial value	Pr.999 = "10"	Pr.999 = "12"	Refer to page
79	Operation mode selection	0	1	1	142
118	RS-485 communication speed	192	192	1152	Instruction Manual (Communication)
119	RS-485 communication stop bit length / data length	1	10	0	
120	RS-485 communication parity check	2	1	1	
121	RS-485 communication retry count	1	9999	9999	
122	RS-485 communication check time interval	0	9999	9999	
123	RS-485 communication waiting time setting	9999	0 ms	0 ms	
124	RS-485 communication CR/LF selection	1	1	1	
340	Communication startup mode selection	0	0	0	152
549	Protocol selection	0	0	0	Instruction Manual (Communication)

■ Initial setting with the GOT2000 series

- When "FREQROL 500/700/800, SENSORLESS SERVO" is selected for "Controller Type" in the GOT setting, set **Pr.999** = "10" to configure the GOT initial setting.
- When "FREQROL 800 (Automatic Negotiation)" is selected for "Controller Type" in the GOT setting, the GOT automatic connection can be used. When "FREQROL 800 (Automatic Negotiation)" is selected for "Controller Type" in the GOT setting and the GOT automatic connection is not used, set **Pr.999** = "12" to configure the GOT initial setting. (Refer to the Instruction Manual (Communication).)

■ Initial setting with the GOT1000 series

- Set **Pr.999** = "10" to configure the GOT initial setting.

NOTE

- Always perform an inverter reset after the initial setting.
- For the details of connection with GOT, refer to the Instruction Manual of GOT.

◆ Rated frequency (Pr.999 = "20" (50 Hz) or "21" (60 Hz))

Pr.	Name	Initial value ^{*1}		Pr.999 = "21"	Pr.999 = "20"	Refer to page
		Gr.1	Gr.2			
3	Base frequency	60 Hz	50 Hz	60 Hz	50 Hz	329
4	Multi-speed setting (high speed)	60 Hz	50 Hz	60 Hz	50 Hz	163
20	Acceleration/deceleration reference frequency	60 Hz	50 Hz	60 Hz	50 Hz	130
53	Frequency / rotation speed unit switchover	0		0		206
55	Frequency monitoring reference	60 Hz	50 Hz	60 Hz	50 Hz	216
66	Stall prevention operation reduction starting frequency	60 Hz	50 Hz	60 Hz	50 Hz	195
125 (903)	Terminal 2 frequency setting gain frequency	60 Hz	50 Hz	60 Hz	50 Hz	248
126 (905)	Terminal 4 frequency setting gain frequency	60 Hz	50 Hz	60 Hz	50 Hz	
386	Frequency for maximum input pulse	60 Hz	50 Hz	60 Hz	50 Hz	159
505	Speed setting reference	60 Hz	50 Hz	60 Hz	50 Hz	206
1013	Running speed after recovery from emergency drive undervoltage	60 Hz	50 Hz	60 Hz	50 Hz	182

*1 Gr.1 and Gr.2 are the parameter initial value groups. (Refer to [page 46.](#))

6.15 Extended parameter display and user group function

Use this parameter to select a group of parameters to be displayed on the operation panel or parameter unit.

Pr.	Name	Initial value	Setting range	Description
160 E440	User group read selection	0	9999	Only simple mode parameters are displayed.
			0	Displays simple mode and extended parameters.
			1	Only parameters registered in user groups are displayed.
172 E441	User group registered display/batch clear	0	(0 to 16)	Displays the number of parameters that are registered in the user groups. (Read-only)
			9999	Batch clear of user group registrations
173 E442	User group registration	9999 ^{*1}	0 to 1999, 9999	Sets the parameter number to register for the user group.
174 E443	User group clear	9999 ^{*1}	0 to 1999, 9999	Sets the parameter number to clear from the user group.

*1 The read value is always "9999".

◆ Display of simple mode parameters and extended parameters (Pr.160)

- When **Pr.160** = "9999", only the simple mode parameters are displayed on the operation panel and parameter unit. (For the simple mode parameters, refer to the parameter list on [page 47](#).)
- With the initial value (**Pr.160** = "0"), simple mode parameters and extended parameters can be displayed.

NOTE

- Every parameter can be read regardless of the **Pr.160** setting when reading parameters via communication.
- When the LCD operation panel (FR-LU08) or parameter unit (FR-PU07) is installed, **Pr.15 Jog frequency**, **Pr.16 Jog acceleration/deceleration time**, **C42 (Pr.934) PID display bias coefficient**, **C43 (Pr.934) PID display bias analog value**, **C44 (Pr.935) PID display gain coefficient**, **C45 (Pr.935) PID display gain analog value**, and **Pr.991 PU contrast adjustment** are displayed as simple mode parameters.

◆ User group function (Pr.160, Pr.172 to Pr.174)

- The user group function is a function for displaying only the parameters required for a setting.
- A maximum of 16 parameters from any of the parameters can be registered in a user group. When **Pr.160** = "1", reading/writing is enabled only for the parameters registered in user groups. (Parameters not registered in user groups can no longer be read.)
- To register a parameter in a user group, set the parameter number in **Pr.173**.
- To clear a parameter from a user group, set the parameter number in **Pr.174**. To batch clear all the registered parameters, set **Pr.172** = "9999".

◆ Registering a parameter in a user group (Pr.173)

- To register **Pr.3** in a user group

Operating procedure

- 1.** Power ON
Make sure the motor is stopped.
- 2.** Changing the operation mode
Press the HAND/AUTO key to choose the PU operation mode. The HAND LED turns ON.
- 3.** Selecting the parameter setting mode
Press the MODE key to choose the parameter setting mode. (The parameter number read previously appears.)
- 4.** Selecting a parameter
Turn the setting dial until "P.173" (**Pr.173**) appears.
- 5.** Parameter read
Press the SET key. "9999" appears.
- 6.** Parameter registration
Turn the setting dial until "3" (**Pr.3**) appears. Press the SET key to register the parameter.
"3" blinks.
To continue adding parameters, repeat steps 5 and 6.

◆ Clearing a parameter from a user group (Pr.174)

- To delete **Pr.3** from a user group

Operating procedure

- 1.** Power ON
Make sure the motor is stopped.
- 2.** Changing the operation mode
Press the HAND/AUTO key to choose the PU operation mode. The HAND LED turns ON.
- 3.** Selecting the parameter setting mode
Press the MODE key to choose the parameter setting mode. (The parameter number read previously appears.)
- 4.** Selecting a parameter
Turn the setting dial until "P.174" (**Pr.174**) appears.
- 5.** Parameter read
Press the SET key. "9999" appears.
- 6.** Clearing the parameter
Turn the setting dial until "3" (**Pr.3**) appears. Press the SET key to delete the parameter.
"3" blinks.
To continue deleting parameters, repeat steps 5 and 6.

NOTE

- **Pr.77 Parameter write selection, Pr.160, Pr.296 Password lock level, Pr.297 Password lock/unlock, and Pr.991 PU contrast adjustment** can always be read regardless of the user group setting. (For **Pr.991**, only when the FR-LU08 or the FR-PU07 is connected.)
- **Pr.77, Pr.160, Pr.172 to Pr.174, Pr.296, and Pr.297** cannot be registered in a user group.
- When **Pr.174** is read, "9999" is always displayed. "9999" can be written, but it does not function.
- **Pr.172** is disabled if set to a value other than "9999".

Parameters referred to

Pr.77 Parameter write selection  [page 109](#)

Pr.296 Password lock level, Pr.297 Password lock/unlock  [page 111](#)

Pr.991 PU contrast adjustment  [page 102](#)

6.16 PWM carrier frequency and Soft-PWM control

The motor sound can be changed.

Pr.	Name	Initial value	Setting range	Description
72 E600	PWM frequency selection	1	0 to 15	The PWM carrier frequency can be changed. The setting value represents the frequency in kHz. Note that "0" indicates 0.7 kHz, "15" indicates 14.5 kHz.
240 E601	Soft-PWM operation selection	1	0	Soft-PWM control disabled.
			1	Soft-PWM control enabled.
260 E602	PWM frequency automatic switchover	10	0	PWM carrier frequency automatic reduction function disabled
			10	PWM carrier frequency automatic reduction function enabled

◆ Changing the PWM carrier frequency (Pr.72)

- The PWM carrier frequency of the inverter can be changed.
- Changing the PWM carrier frequency can be effective for avoiding the resonance frequency of the mechanical system or motor, as a countermeasure against EMI generated from the inverter, or for reducing leakage current caused by PWM switching.
- Under PM sensorless vector control, the following carrier frequencies are used.

Pr.72 setting	Carrier frequency (kHz)	
	Driving a PM motor other than EM-A	Driving an EM-A motor
0 to 5	2	4
6, 7	6*1	8
8, 9		
10 to 13	10*1	
14, 15	14*1	

*1 When the load is high, the carrier frequency is automatically changed to 2 kHz.

NOTE

- The carrier frequency may be automatically lowered. Motor noise increases, but not to the point of failure.

◆ Soft-PWM control (Pr.240)

- Soft-PWM control is a function that changes the motor noise from a metallic sound into an inoffensive, complex tone.
- Setting **Pr.240** = "1" will enable the Soft-PWM control.
- To enable the Soft-PWM control, set **Pr.72** to 5 kHz or less.

◆ PWM carrier frequency automatic reduction function (Pr.260)

- Setting **Pr.260** = "10 (initial value)" will enable the PWM carrier frequency auto-reduction function. If a heavy load is continuously applied while the inverter carrier frequency is set to 3 kHz or higher (**Pr.72** ≥ "3"), the carrier frequency is automatically reduced to prevent occurrence of the inverter overload trip (electronic thermal O/L relay function) (E.THT). Motor noise increases, but not to the point of failure.
- When the PWM carrier frequency automatic reduction function is used, operation with the carrier frequency set to 3 kHz or higher (**Pr.72** ≥ 3) automatically reduces the carrier frequency for heavy-load operation as shown below.

Pr.260 setting	Pr.570 setting	Carrier frequency automatic reduction operation
10	0 (SLD)	The carrier frequency will reduce automatically with continuous operation of 85% of the inverter rated current or higher.
	2 (ND)	For the FR-D820-7.5K-318 or lower, the FR-D840-7.5K-163 or lower, the FR-D820S-2.2K-100 or lower, and the FR-D810W-0.75K-042 or lower, the carrier frequency will reduce automatically with operation of 150% of the inverter rated current or higher. For the FR-D820-11K-450 or higher and the FR-D840-11K-230 or higher, the carrier frequency will reduce automatically with operation of 120% of the inverter rated current or higher.
0	0 (SLD)	Without carrier frequency automatic reduction (Perform continuous operation with the carrier frequency set to 2 kHz or lower or with less than 85% of the inverter rated current.)
	2 (ND)	Without carrier frequency automatic reduction

NOTE

- Reducing the PWM carrier frequency is effective as a countermeasure against EMI from the inverter or for reducing leakage current, but doing so increases the motor noise.
- When the PWM carrier frequency is set to 1 kHz or lower (**Pr.72** ≤ 1), the increase in the harmonic current causes the fast-response current limit to activate before the stall prevention operation, which may result in torque shortage. In this case, disable the fast-response current limit in **Pr.156 Stall prevention operation selection**.
- The carrier frequency is reduced to as low as 4 kHz under PM sensorless vector control (when driving the EM-A motor).

« Parameters referred to »

Pr.156 Stall prevention operation selection  [page 195](#)

Pr.570 Multiple rating setting  [page 108](#)

Pr.800 Control method selection  [page 72](#)

6.17 Inverter parts life display

The degree of deterioration of the control circuit capacitor, main circuit capacitor, cooling fan, inrush current limit circuit, relay contacts of terminals A, B, and C, and inverter module can be diagnosed on the monitor. When a part approaches the end of its life, an alarm can be output by self diagnosis to prevent a fault. (Note that the life diagnosis of this function should be used as a guideline only, the life values are theoretical calculations.)

Pr.	Name	Initial value	Setting range	Description
255 E700	Life alarm status display	0	(0 to 367)	Displays whether or not the life alarm output level is reached for the following parts: the control circuit capacitor, main circuit capacitor, cooling fan, inrush current limit circuit, relay contacts of terminals A, B, and C, and inverter module. Read-only.
256 E701	Inrush current limit circuit life display	100%	(0% to 100%)	Displays the deterioration degree of the inrush current limit circuit. Read-only.
257 E702	Control circuit capacitor life display	100%	(0% to 100%)	Displays the deterioration degree of the control circuit capacitor. Read-only.
258 E703	Main circuit capacitor life display	100%	(0% to 100%)	Displays the deterioration degree of the main circuit capacitor. Read-only. The value measured by Pr.259 is displayed.
259 E704	Main circuit capacitor life measuring	0	0, 1 (2, 3, 8, 9)	Setting "1" and turning the power supply OFF starts the measurement of the main circuit capacitor life. If the setting value of Pr.259 becomes "3" after turning the power supply ON again, it means that the measurement is completed. The degree of deterioration is read to Pr.258.
506 E705	Display estimated main circuit capacitor residual life	100%	(0% to 100%)	Displays the estimated residual life of the main circuit capacitor. Read-only.
507 E706	Display/reset ABC relay contact life	100%	(0% to 100%)	Displays the degree of deterioration of the relay contacts of terminals A, B, and C. Read-only.
509 E708	Display power cycle life	100%	(0% to 100%)	Displays the degree of deterioration of the inverter module. Read-only.

◆ Life alarm display and signal output (Y90 signal, Pr.255)

Point

- In the life diagnosis of the main circuit capacitor, the Life alarm (Y90) signal is not output unless measurement by turning OFF the power supply is performed.

- **Pr.255 Life alarm status display** and the Life alarm (Y90) signal can be used to check whether or not the life alarm output level is reached for the following parts: the control circuit capacitor, main circuit capacitor, cooling fan, inrush current limit circuit, relay contacts of terminals A, B, and C, or inverter module.

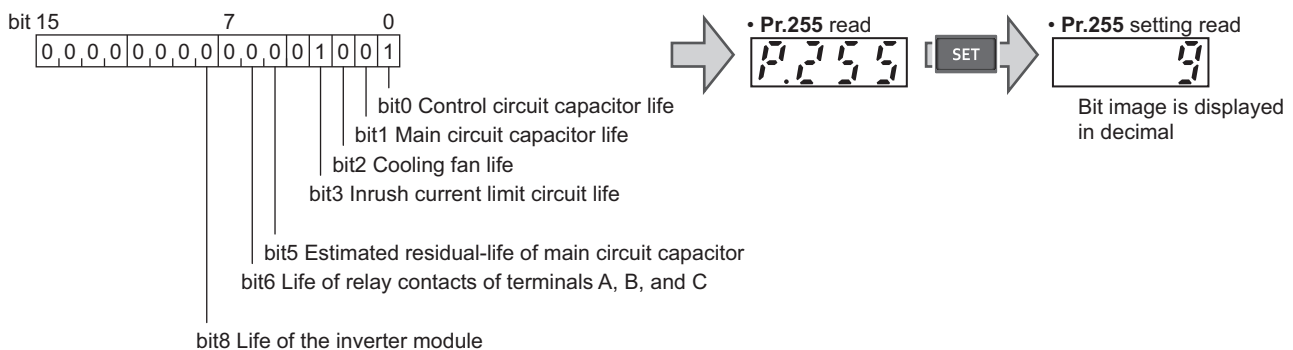

- When the parts have reached the life alarm output level, the corresponding bits of **Pr.255** turns ON. The ON/OFF state of the bits can be checked with **Pr.255**. The following table shows examples.

Pr.255		bit 9	bit 8	bit 7	bit 6	bit 5	bit 4	bit 3	bit 2	bit 1	bit 0	Remarks
Decimal	Binary											
367	0101101111	x	o	x	o	o	x	o	o	o	o	All parts have reached alarm output level.
5	101	x	x	x	x	x	x	x	o	x	o	Control circuit capacitor and cooling fan have reached alarm output level.
0	0	x	x	x	x	x	x	x	x	x	x	No parts have reached alarm output level.

o: Parts reaching alarm output level x: Parts not reaching alarm output level

- The Life alarm (Y90) signal turns ON when the life alarm output level is reached for either of the following: the control circuit capacitor, main circuit capacitor, cooling fan, inrush current limit circuit, relay contacts of terminals A, B, and C, inverter module, and for the estimated residual life of the main circuit capacitor.
- For the terminal used for the Y90 signal, set "90" (positive logic) or "190" (negative logic) in any parameter from **Pr.190 to Pr.196 (Output terminal function selection)**.

NOTE

- Changing the terminal assignment using **Pr.190 to Pr.196 (Output terminal function selection)** may affect the other functions. Set parameters after confirming the function of each terminal.
- For replacement of each part, contact the nearest Mitsubishi Electric FA center.

◆ Life display of the inrush current limit circuit (Pr.256)

- The life of the inrush current limit circuit (relay, contactor and inrush resistor) is displayed in **Pr.256**.
- The number of contact (relay, contactor, thyristor) ON times is counted, and it is counted down from 100% (0 time) every 1%/10,000 times. When the counter reaches 10% (900,000 times), bit 3 of **Pr.255** is turned ON and the Y90 signal is also output as an alert.

◆ Life display of the control circuit capacitor (Pr.257)

- The deterioration degree of the control circuit capacitor is displayed in **Pr.257**.
- In the operating status, the control circuit capacitor life is calculated from the energization time and temperature, and is counted down from 100%. When the remaining life of the control circuit capacitor reaches 9%, bit 0 of **Pr.255** turns ON and the Y90 signal is also output as an alert.

◆ Life display of the main circuit capacitor (Pr.258, Pr.259)

Point

- For accurate life measurement of the main circuit capacitor, wait three hours or longer after turning OFF. The temperature left in the main circuit capacitor affects measurement.

- The deterioration degree of the main circuit capacitor is displayed in **Pr.258**.
- With the main circuit capacitor capacity at factory shipment as 100%, the capacitor life is displayed in **Pr.258** every time measurement is made. When the measured value falls to 85% or lower, bit 1 of **Pr.255** turns ON and the Y90 signal is also output as an alert.
- Measure the capacitor capacity according to the following procedure and check the deterioration degree of the capacitor capacity.

1. Check that the motor is connected and at a stop.
2. Set "1" (measuring start) in **Pr.259**.
3. Switch the power OFF. The inverter applies DC voltage to the motor to measure the capacitor capacity while the inverter is OFF.
4. After confirming that the LED of the operation panel is OFF, power ON again.
5. Check that "3" (measurement complete) is set in **Pr.259**, read **Pr.258**, and check the deterioration degree of the main circuit capacitor.

Pr.259	Description	Remarks
0	No measurement	Initial value
1	Start measurement	Measurement starts when the power supply is switched OFF.
2	During measurement	Only displayed and cannot be set.
3	Measurement complete	
8	Forced end	
9	Measurement error	

NOTE

- When the main circuit capacitor life is measured under the following conditions, "forced end" (**Pr.259** = "8") or "measurement error" (**Pr.259** = "9") may occur, or the status may remain in "measurement start" (**Pr.259** = "1"). To perform measurement, first eliminate the following conditions. Under the following conditions, even if "measurement complete" (**Pr.259** = "3") is reached, measurement cannot be performed correctly.

Condition in which measurement cannot be performed	Condition in which the measured value may fluctuate
<ul style="list-style-type: none"> • FR-HC2 or FR-XC is connected. • The power supply is switched ON during measurement. • The motor is not connected to the inverter. • The inverter output is shut off or a fault occurred while the power was OFF. • The inverter output is shut off with the MRS signal. • The start command is given while measuring. 	<ul style="list-style-type: none"> • DC power supply is connected to terminals P/+ and N/-. • The motor is running (coasting). • The motor capacity is smaller than the inverter capacity by two ranks or more. • The applied motor setting is incorrect. • The parameter unit (FR-PU07) is connected. • Terminal PC is used for power supply. • An I/O terminal of the control circuit terminal block is ON (continuity). • The wiring length is long.

- Operation environment: Surrounding air temperature (annual average of 40°C (free from corrosive gas, flammable gas, oil mist, dust and dirt)).
Output current: 80% of the inverter rating
- Since repeated inrush currents at power ON will shorten the life of the converter circuit, frequent starts and stops of the magnetic contactor must be avoided.

⚠ WARNING

- When measuring the main circuit capacitor capacity (**Pr.259** = "1"), the DC voltage is applied to the motor for about one second at power OFF. Never touch the motor terminal, etc. right after powering OFF to prevent an electric shock.

◆ Life display of the cooling fan

- If a cooling fan speed of less than the specified speed is detected, Fan alarm "FN" is displayed on the operation panel or the parameter unit. As an alert output, bit 2 of **Pr.255** turns ON, and the Y90 signal and Alarm (LF) signal are also output.
- For the terminal used for the LF signal, set "98" (positive logic) or "198" (negative logic) in any parameter from **Pr.190 to Pr.196 (Output terminal function selection)**.

NOTE

- When the inverter is mounted with two or more cooling fans, "FN" is displayed even only one of the fans is detected.
- Changing the terminal assignment using **Pr.190 to Pr.196 (Output terminal function selection)** may affect the other functions. Set parameters after confirming the function of each terminal.

◆ Display estimated main circuit capacitor residual life (Pr.506)

- Even when the power supply cannot be turned OFF, the remaining life of the main circuit capacitor can be estimated without stopping the operation. Note that the remaining life of the main circuit capacitor estimated by this function is theoretical, and should be used as a guideline only.
- The estimated residual life of the main circuit capacitor is displayed in **Pr.506**.
- The remaining life of the main circuit capacitor is calculated from the energization time and the inverter output power (100% = Start of service life). When the remaining life of the main circuit capacitor reaches 9%, bit 5 of **Pr.255** turns ON and a warning is output by the Y90 signal.

◆ Life display of the relay contacts of terminals A, B, and C (Pr.507)

- The degree of deterioration of the relay contacts of terminals A, B, and C is displayed in **Pr.507**.
- The number of times the contacts of relay turn ON is counted down from 100% (0 time) by 1% (500 times). When the counter reaches 10% (45,000 times), bit 6 of **Pr.255** is turned ON and the Y90 signal is also output as an alert.

◆ Life display of the inverter module (Pr.509)

- The degree of deterioration of the inverter module is displayed in **Pr.509**.
- The degree of deterioration of the inverter module is determined by the change in the surrounding air temperature of the module. (The degree is counted down from 100% (no deterioration).) When the remaining life of the inverter module reaches 15%, bit 8 of **Pr.255** turns ON and a warning is output by the Y90 signal.

6.18 Maintenance timer alarm

The Maintenance timer (Y95) signal is output when the inverter's cumulative energization time reaches the time period set with the parameter. "MT" is displayed on the operation panel. This can be used as a guideline for the maintenance time of peripheral devices.

Pr.	Name	Initial value	Setting range	Description
503 E710	Maintenance timer	0	0 (1 to 9998)	Displays the inverter's cumulative energization time in increments of 100 hours (read-only). Writing the setting of "0" clears the cumulative energization time while Pr.503 = "1 to 9998". (Writing is disabled when Pr.503 = "0".)
504 E711	Maintenance timer warning output set time	9999	0 to 9998	Set the cumulative energization time in 100 hours which triggers the Maintenance timer (Y95) signal output.
			9999	Without the function

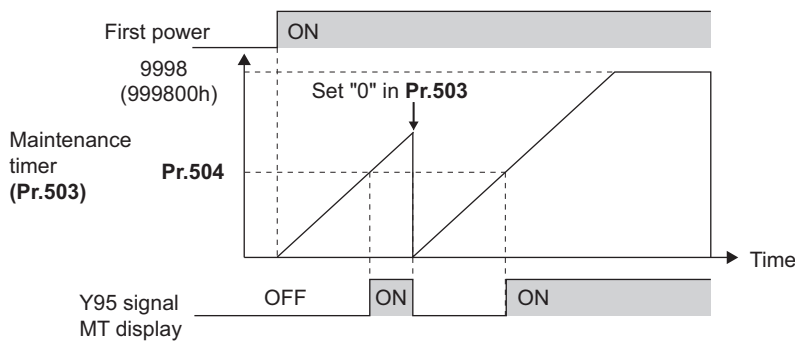

Operation example of the maintenance timer

- The cumulative energization time of the inverter is stored in the EEPROM every hour and displayed in **Pr.503** in 100 h increments. The number indication on **Pr.503** stopped at 9998 (999800 hours).
- When the value in **Pr.503** reaches the time (100 h increments) set in **Pr.504**, the Maintenance timer (Y95) signal is output, and also "MT" is displayed on the operation panel.
- For the Y95 signal output, set "95" (positive logic) or "195" (negative logic) in any parameter from **Pr.190 to Pr.196 (Output terminal function selection)** to assign the function.

NOTE

- The cumulative energization time is counted every hour. Energization time of less than 1 h is not counted.
- Changing the terminal assignment using **Pr.190 to Pr.196 (Output terminal function selection)** may affect the other functions. Set parameters after confirming the function of each terminal.

« Parameters referred to »

Pr.190 to Pr.196 (Output terminal function selection) [page 226](#)

6.19 Current average value monitor signal

The output current average value during constant-speed operation and the maintenance timer value are output to the Current average monitor (Y93) signal as a pulse. The output pulse width can be used in a device such as the I/O unit of a programmable controller as a guideline for the maintenance time for mechanical wear, belt stretching, or deterioration of devices with age. The pulse is repeatedly output during constant-speed operation in cycles of 20 seconds to the Current average monitor (Y93) signal.

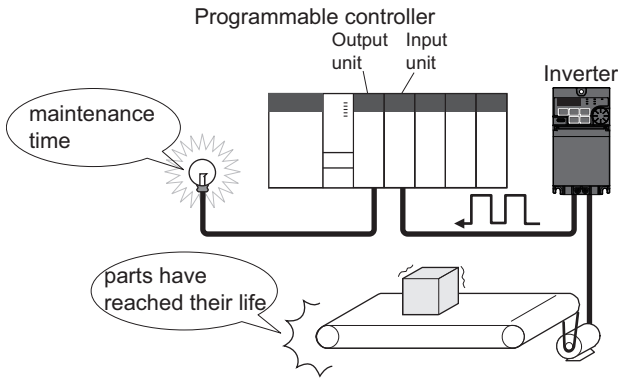

Pr.	Name	Initial value	Setting range	Description
555 E720	Current average time	1 s	0.1 to 1 s	Set the time for calculating the average current during start pulse output (1 second).
556 E721	Data output mask time	0 s	0 to 20 s	Set the time for not obtaining (masking) transitional state data.
557 E722	Current average value monitor signal output reference current	Inverter rated current	0 to 500 A	Set the reference (100%) for outputting the output current average value signal.

◆ Operation example

- The pulse output of the Current average monitor (Y93) signal is indicated below.
- For the Y93 signal output, set "93" (positive logic) or "193" (negative logic) in any parameter of **Pr.190**, **Pr.191**, **Pr.193** to **Pr.196 (Output terminal function selection)** to assign the function. (The function cannot be assigned by using **Pr.192**.)

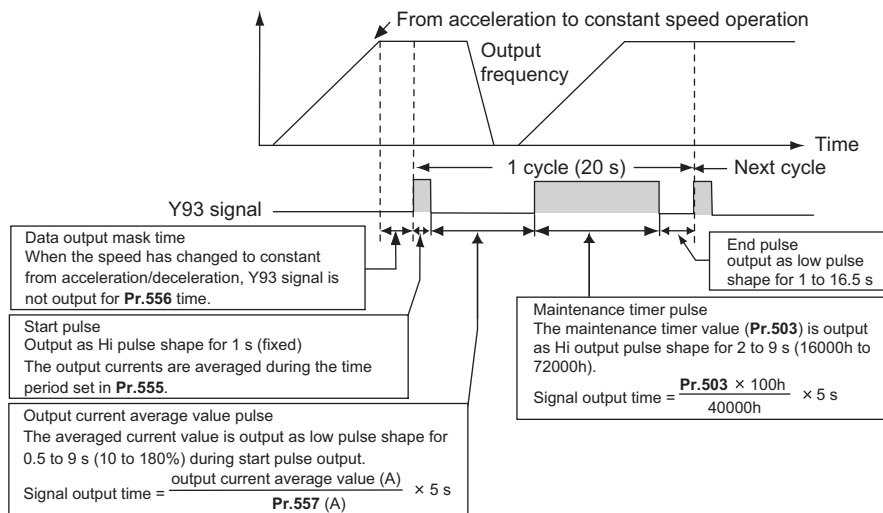

◆ Pr.556 Data output mask time setting

- Immediately after acceleration/deceleration is shifted to constant-speed operation, the output current is unstable (transitional state). Set the time for not obtaining (masking) transitional state data in **Pr.556**.

◆ Pr.555 Current average time setting

- The output current average is calculated during start pulse (1 second) HIGH output. Set the time for calculating the average current during start pulse output in **Pr.555**.

◆ Pr.557 Current average value monitor signal output reference current setting

Set the reference (100%) for outputting the output current average value signal. The signal output time is calculated with the following formula.

$$\frac{\text{Output current average value}}{\text{Pr.557 setting value}} \times 5 \text{ s} \quad (\text{Output current average value } 100\%/5 \text{ s})$$

The output time range is 0.5 to 9 seconds. When the output current average value is less than 10% of the setting value in **Pr.557**, the output time is 0.5 second, and when it is more than 180%, the output time is 9 seconds.

For example, when **Pr.557** = 10 A and the output current average value is 15 A:

$15 \text{ A} / 10 \text{ A} \times 5 \text{ s} = 7.5 \text{ s}$, thus the Current average monitor signal maintains LOW output for 7.5 seconds.

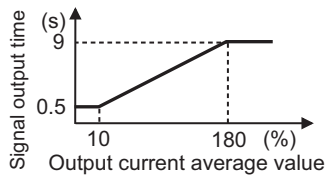

◆ Pr.503 Maintenance timer output

After LOW output of the output current value is performed, HIGH output of the maintenance timer value is performed. The maintenance timer value output time is calculated with the following formula.

$$\frac{\text{Pr.503} \times 100}{40000\text{h}} \times 5 \text{ s} \quad (\text{Maintenance timer value } 100\%/5 \text{ s})$$

The output time range is 2 to 9 seconds. When **Pr.503** is less than 16000 hours, the output time is 2 seconds. When it is more than 72000 hours, the output time is 9 seconds.

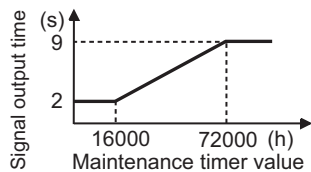

NOTE

- Masking of the data output and sampling of the output current are not performed during acceleration/deceleration.
- If constant speed changes to acceleration or deceleration during start pulse output, it is judged as invalid data, and the signal maintains HIGH start pulse output for 3.5 seconds and LOW end pulse output for 16.5 seconds. After the start pulse output is completed, minimum 1-cycle signal output is performed even if acceleration/deceleration is performed.

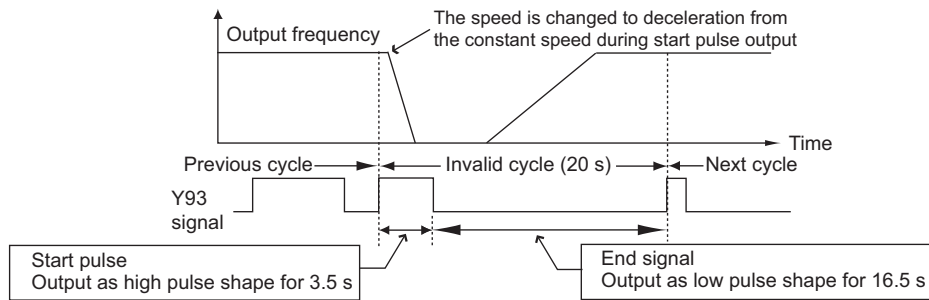

- If the output current value (inverter output current monitor) is 0 A at the completion of the 1-cycle signal output, no signal is output until the next constant-speed state.
- Under the following conditions, the Y93 signal maintains LOW output for 20 seconds (no data output).
 - When acceleration or deceleration is operating at the completion of the 1-cycle signal output
 - When automatic restart after instantaneous power failure (**Pr.57 Restart coasting time** ≠ "9999") is set, and the 1-cycle signal output is completed during the restart operation.
 - When automatic restart after instantaneous power failure (**Pr.57** ≠ "9999") is set, and the restart operation was being performed at the completion of data output masking.
- Changing the terminal assignment using **Pr.190 to Pr.196 (Output terminal function selection)** may affect the other functions. Set parameters after confirming the function of each terminal.

« Parameters referred to »

Pr.57 Restart coasting time [page 307](#), [page 312](#)

Pr.190 to Pr.196 (Output terminal function selection) [page 226](#)

Pr.503 Maintenance timer [page 126](#)

7 (F) Settings for Acceleration/Deceleration

Purpose	Parameter to set			Refer to page
To set the motor acceleration/ deceleration time	Acceleration/deceleration time	P.F000, P.F002, P.F003, P.F010, P.F011, P.F020, P.F021, P.F070, P.F071	Pr.7, Pr.8, Pr.16, Pr.20, Pr.44, Pr.45, Pr.611, Pr.791, Pr.792	130
To set the acceleration/deceleration pattern suitable for an application	Acceleration/deceleration pattern	P.F100	Pr.29	133
To command smooth speed transition with terminals	Remote setting function	P.F101	Pr.59	135
To set the starting frequency	Starting frequency and start-time hold	P.F102, P.F103	Pr.13, Pr.571	139, 141

7.1 Setting the acceleration and deceleration time

The following parameters are used to set motor acceleration/deceleration time.

Set a larger value for a slower acceleration/deceleration, or a smaller value for a faster acceleration/deceleration.

For the acceleration time at automatic restart after instantaneous power failure, refer to **Pr.611 Acceleration time at a restart** (page 307, page 312).

Pr.	Name	Initial value ^{*1}		Setting range	Description
		Gr.1	Gr.2		
20 F000	Acceleration/ deceleration reference frequency	60 Hz	50 Hz	1 to 590 Hz	Set the frequency that is the basis of acceleration/deceleration time. As acceleration/deceleration time, set the time required to change the frequency from stop status (0 Hz) to the frequency set in Pr.20 and vice versa.
16 F002	Jog acceleration/ deceleration time	0.5 s		0 to 3600 s	Set the acceleration/deceleration time for JOG operation (from stop status to Pr.20). Refer to page 161.
611 F003	Acceleration time at a restart	9999		0 to 3600 s	Set the acceleration time (time required to change the frequency from stop status (0 Hz) to the frequency set in Pr.20) for restart.
				9999	Standard acceleration time (for example, Pr.7) is applied as the acceleration time at restart. Refer to page 307, page 312.
7 F010	Acceleration time	5 s ^{*2}		0 to 3600 s	Set the motor acceleration time (time required to change the frequency from stop status (0 Hz) to the frequency set in Pr.20).
		10 s ^{*3}			
		15 s ^{*4}			
8 F011	Deceleration time	5 s ^{*2}		0 to 3600 s	Set the motor deceleration time (time required to change the frequency from the frequency set in Pr.20 to stop status (0 Hz)).
		10 s ^{*3}			
		15 s ^{*4}			
44 F020	Second acceleration/ deceleration time	5 s ^{*2}		0 to 3600 s	Set the acceleration/deceleration time used while the RT signal is ON.
		10 s ^{*3}			
		15 s ^{*4}			
45 F021	Second deceleration time	9999		0 to 3600 s	Set the deceleration time used while the RT signal is ON.
				9999	The acceleration time applies to the deceleration time.
791 F070	Acceleration time in low-speed range	9999		0 to 3600 s	Set the acceleration time in a low-speed range.
				9999	The acceleration time set in Pr.7 is applied. (While the RT signal is ON, the second function is enabled.)
792 F071	Deceleration time in low-speed range	9999		0 to 3600 s	Set the deceleration time in a low-speed range.
				9999	The deceleration time set in Pr.8 is applied. (While the RT signal is ON, the second function is enabled.)

*1 Gr.1 and Gr.2 are the parameter initial value groups. (Refer to page 46.)

*2 Initial value for the FR-D820-3.7K-165 or lower, the FR-D840-3.7K-081 or lower, the FR-D820S-2.2K-100 or lower, and the FR-D810W-0.75K-042 or lower.

*3 Initial value for the FR-D820-5.5K-238, FR-D820-7.5K-318, FR-D840-5.5K-120, and FR-D840-7.5K-163.

*4 Initial value for the FR-D820-11K-450 or higher and the FR-D840-11K-230 or higher.

◆ Control block diagram

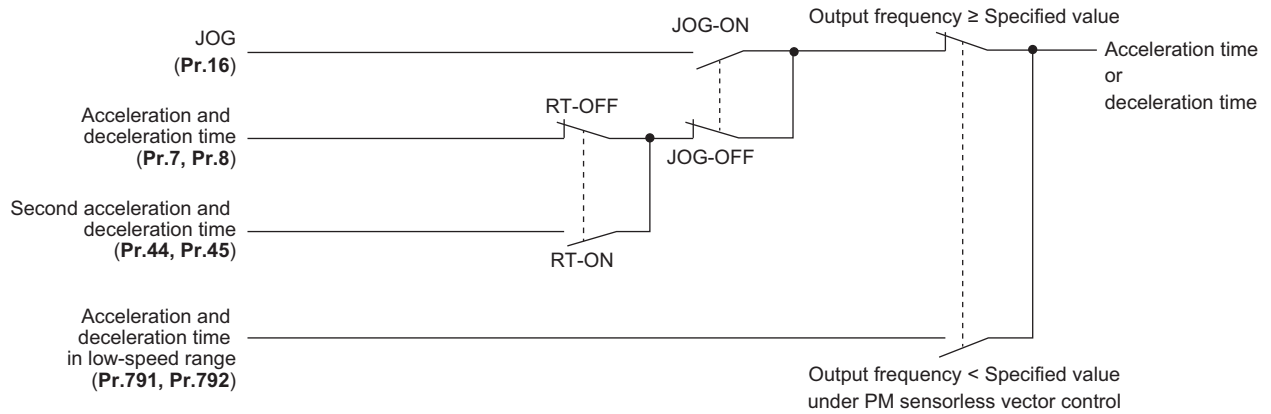

◆ Acceleration time setting (Pr.7, Pr.20)

- Use **Pr.7 Acceleration time** to set the acceleration time required to change the frequency to the frequency set in **Pr.20 Acceleration/deceleration reference frequency** from stop status.
- Set the acceleration time according to the following formula.

$$\text{Acceleration time setting} = \text{Pr.20} \times \text{Acceleration time from stop status to maximum frequency} / (\text{Maximum frequency} - \text{Pr.13})$$

- For example, the following calculation is performed to find the setting value for **Pr.7** when increasing the output frequency to the maximum frequency of 50 Hz in 10 seconds with **Pr.20 = "60 Hz (initial value)"** and **Pr.13 = "0.5 Hz"**.

$$\text{Pr.7 setting} = 60 \text{ Hz} \times 10 \text{ s} / (50 \text{ Hz} - 0.5 \text{ Hz}) \approx 12.1 \text{ s}$$

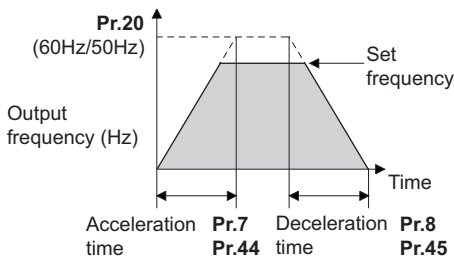

◆ Deceleration time setting (Pr.8, Pr.20)

- Use **Pr.8 Deceleration time** to set the deceleration time required to change the frequency to a stop status from the frequency set in **Pr.20 Acceleration/deceleration reference frequency**.
- Set the deceleration time according to the following formula.

$$\text{Deceleration time setting} = \text{Pr.20} \times \text{deceleration time from maximum frequency to stop} / (\text{maximum frequency} - \text{Pr.10})$$

- For example, the following calculation is used to find the setting value for **Pr.8** when decreasing the output frequency from the maximum frequency of 50 Hz in 10 seconds with **Pr.20 = 120 Hz** and **Pr.10 = 3 Hz**.

$$\text{Pr.8 setting} = 120 \text{ Hz} \times 10 \text{ s} / (50 \text{ Hz} - 3 \text{ Hz}) \approx 25.5 \text{ s}$$

NOTE

- If the acceleration/deceleration time is set, the actual motor acceleration/deceleration time cannot be made shorter than the shortest acceleration/deceleration time determined by the mechanical system J (moment of inertia) and motor torque.
- If the **Pr.20** setting is changed, the settings of **Pr.125** and **Pr.126 (frequency setting signal gain frequency)** do not change.
Set **Pr.125** and **Pr.126** to adjust the gains.
- Under PM sensorless vector control, if the protective function (E.OLT) is activated due to insufficient torque in the low-speed range, set longer acceleration/deceleration times only in the low-speed range in **Pr.791 Acceleration time in low-speed range** and **Pr.792 Deceleration time in low-speed range**.

◆ Setting two acceleration/deceleration times (RT signal, Pr.44, Pr.45)

- **Pr.44 and Pr.45** are applied when the RT signal is ON. To input the RT signal, set "3" in any parameter from **Pr.178 to Pr.182 and Pr.185 to Pr.189 (Input terminal function selection)** to assign the function.
- When "9999" is set in **Pr.45**, the deceleration time becomes equal to the acceleration time (time set in **Pr.44**).

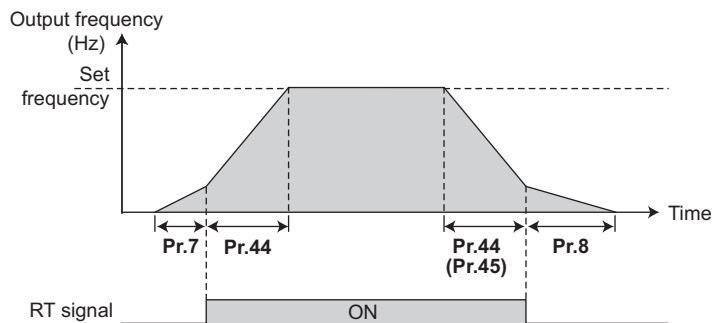

NOTE

- The reference frequency during acceleration/deceleration depends on the **Pr.29 Acceleration/deceleration pattern selection** setting. (Refer to [page 133](#).)
- Changing the terminal assignment using **Pr.178 to Pr.182 and Pr.185 to Pr.189 (Input terminal function selection)** may affect the other functions. Set parameters after confirming the function of each terminal.
- The RT signal is the Second function selection signal. The RT signal also enables other second functions. (Refer to [page 257](#).)

◆ Setting the acceleration/deceleration time in the low-speed range (Pr.791, Pr.792)

- If torque is required in the low-speed range (lower than 10% of the rated motor frequency) under PM sensorless vector control, set the **Pr.791 Acceleration time in low-speed range** and **Pr.792 Deceleration time in low-speed range** settings higher than the **Pr.7 Acceleration time** and **Pr.8 Deceleration time** settings so that the mild acceleration/deceleration is performed in the low-speed range. (When the RT signal is turned ON, the second acceleration/deceleration time is prioritized.)

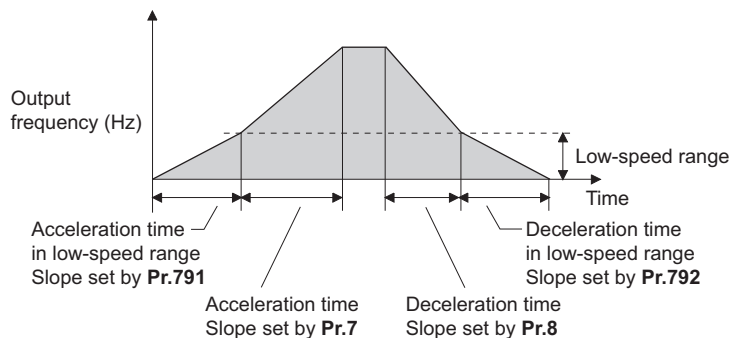

NOTE

- Set **Pr.791 (Pr.792)** to a value larger than the **Pr.7 (Pr.8)** setting. If set as **Pr.791 < Pr.7**, the operation is performed as **Pr.791 = Pr.7**. If set as **Pr.792 < Pr.8**, the operation is performed as **Pr.792 = Pr.8**.
- **Pr.791 and Pr.792** are enabled under PM sensorless vector control.
- For the rated current of the EM-A motor, refer to the Instruction Manual (Connection).

Parameters referred to

Pr.3 Base frequency [page 329](#)

Pr.10 DC injection brake operation frequency [page 335](#)

Pr.29 Acceleration/deceleration pattern selection [page 133](#)

Pr.125, Pr.126 (Frequency setting gain frequency) [page 248](#)

Pr.178 to Pr.182 and Pr.185 to Pr.189 (Input terminal function selection) [page 252](#)

7.2 Acceleration/deceleration pattern

The acceleration/deceleration pattern can be set according to the application.

Pr.	Name	Initial value	Setting range	Description
29 F100	Acceleration/deceleration pattern selection	0	0	Linear acceleration/deceleration
			1	S-pattern acceleration/deceleration A
			2	S-pattern acceleration/deceleration B

◆ Linear acceleration/deceleration (Pr.29 = "0 (initial value)")

- When the frequency is changed for acceleration, deceleration, etc. during inverter operation, the output frequency is changed linearly (linear acceleration/deceleration) to reach the set frequency without straining the motor and inverter. Linear acceleration/deceleration has a uniform frequency/time slope.

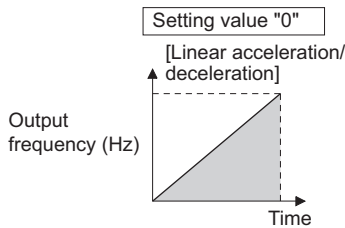

◆ S-pattern acceleration/deceleration A (Pr.29 = "1")

- Use this when acceleration/deceleration is required for a short time until a high-speed area equal to or higher than the base frequency, such as for the main shaft of the machine.
- The acceleration/deceleration pattern has **Pr.3 Base frequency (Pr.84 Rated motor frequency** under PM sensorless vector control) (fb) as the point of inflection in an S-pattern curve, and the acceleration/deceleration time can be set to be suitable for the motor torque reduction in the constant-power operation range at the base frequency (fb) or more.

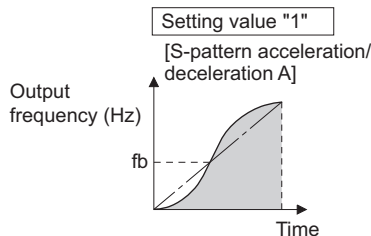

- Acceleration/deceleration time calculation method when the set frequency is equal to or higher than the base frequency

$$\text{Acceleration time } t = (4/9) \times (T/fb^2) \times f^2 + (5/9) \times T$$

Where T is the acceleration/deceleration time (s), f is the set frequency (Hz), and fb is the base frequency (rated motor frequency)

- Reference (0 Hz to set frequency) of acceleration/deceleration time when **Pr.3 = 60 Hz**

Acceleration/deceleration time (s)	Set frequency (Hz)			
	60	120	200	400
5	5	12	27	102
15	15	35	82	305

NOTE

- For the acceleration/deceleration time setting of the S-pattern acceleration/deceleration A, set the time to **Pr.3 (Pr.84** under PM sensorless vector control) instead of **Pr.20 Acceleration/deceleration reference frequency**.

◆ S-pattern acceleration/deceleration B (Pr.29 = "2")

- This is useful for preventing collapsing stacks such as on a conveyor. S-pattern acceleration/deceleration B can reduce the impact during acceleration/deceleration by accelerating/decelerating while maintaining an S-pattern from the present frequency (f2) to the target frequency (f1).

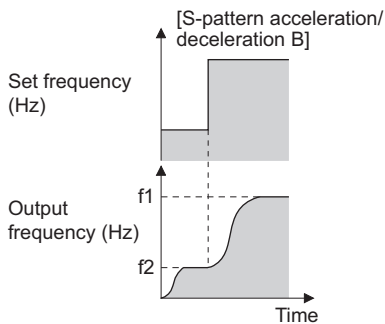

NOTE

- When the RT signal turns ON during acceleration or deceleration with the S-pattern acceleration/deceleration B enabled, a pattern of acceleration or deceleration changes to linear at the moment.
- When the acceleration/deceleration time (such as **Pr.7** and **Pr.8**) is set to 0 s under PM sensorless vector control, linear acceleration and deceleration are performed for the S-pattern acceleration/deceleration (**Pr.29** = "1 or 2").

Parameters referred to

Pr.3 Base frequency [page 329](#)

Pr.7 Acceleration time, Pr.8 Deceleration time, Pr.20 Acceleration/deceleration reference frequency [page 130](#)

7.3 Remote setting function

Even if the operation panel is located away from the enclosure, contact signals can be used to perform continuous variable-speed operation, without using analog signals.

Pr.	Name	Initial value	Setting range	Description	
				RH, RM, RL signal function	Frequency setting storage
59 F101	Remote function selection	0	0	Multi-speed setting	—
			1	Remote setting	Enabled
			2	Remote setting	Disabled
			3	Remote setting	Disabled (Turning OFF the STF/STR signal clears the remotely-set frequency.)
			4	Remote setting (RM signal disabled)	Disabled

◆ Remote setting function

- When Pr.59 = "1 to 3" (remote setting enabled), the functions of the signals are as shown in the following table.

Signal name	Function	Description
STF/STR	Forward/Reverse	The inverter accelerates the motor in the forward or reverse direction up to the main speed or to the set frequency.
RH	Acceleration	The set frequency increases according to the Pr.44 setting.
RM	Deceleration	The set frequency decreases according to the Pr.45 setting.
RL	Clear	The set frequency is cleared and the main speed is applied.
Terminal 2 (analog signal)	Main speed	The setting of the main speed is used as a base. The main speed is increased by the RH signal and decreased by the RM signal.

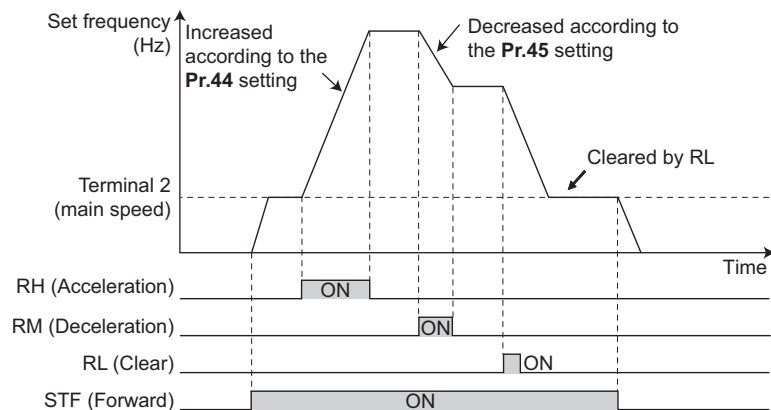
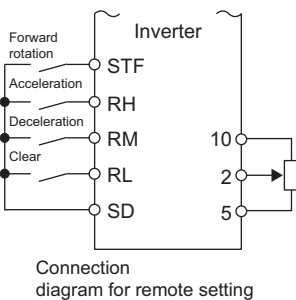

- When Pr.59 = "4" (remote setting enabled), the functions of the signals are as shown in the following table.

Signal name	Function	Description
STF/STR	Forward/Reverse	The inverter accelerates the motor in the forward or reverse direction up to the main speed or to the set frequency. When the STF/STR signal is OFF, the set frequency decreases according to the Pr.45 setting.
RH	Acceleration	The set frequency increases according to the Pr.44 setting.
RL	Clear	The set frequency is cleared and the main speed is applied.
Terminal 2 (analog signal)	Main speed	The setting of the main speed is used as a base. The main speed is increased by the RH signal and decreased by turning OFF the STF/STR signal.

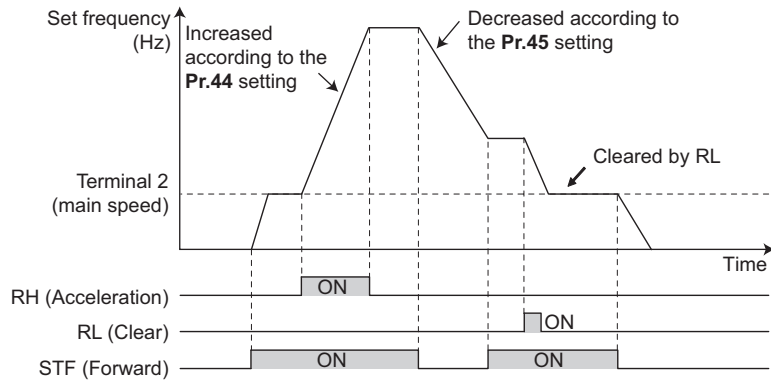
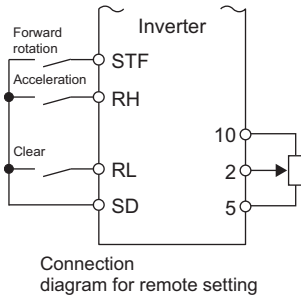

◆ Main speed

- The main speed used in the remote setting corresponds with each of the following operation modes.

Operation mode	Main speed
PU operation mode / NET operation mode	Digital setting
External operation mode / PU/External combined operation mode 2 (Pr.79 = "4")	Analog input
PU/External combined operation mode 1 (Pr.79 = "3")	Analog input via terminal 4 (AU signal ON)

◆ Acceleration/deceleration operation

- The output frequency changes as follows when the set frequency is changed by the remote setting function.

Frequency	Time setting	Description
Set frequency	Pr.44/Pr.45	The set frequency increases/decreases by remote setting according to the Pr.44/Pr.45 setting.
Output frequency	Pr.7/Pr.8	The output frequency increases/decreases by the set frequency according to the Pr.7/Pr.8 setting.

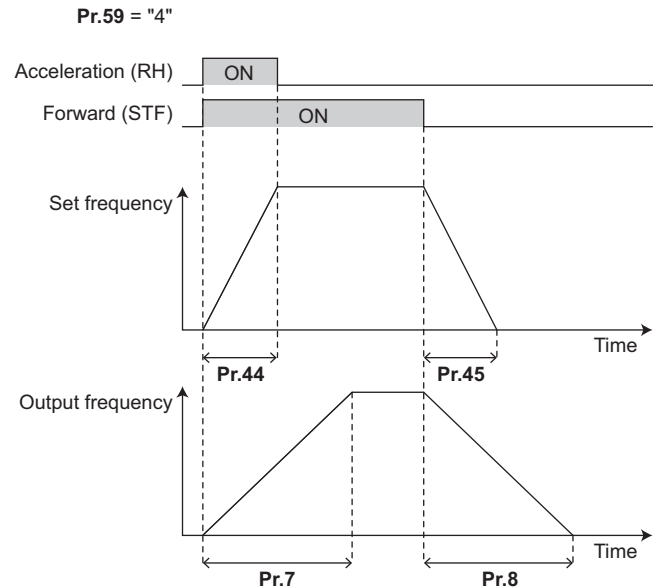
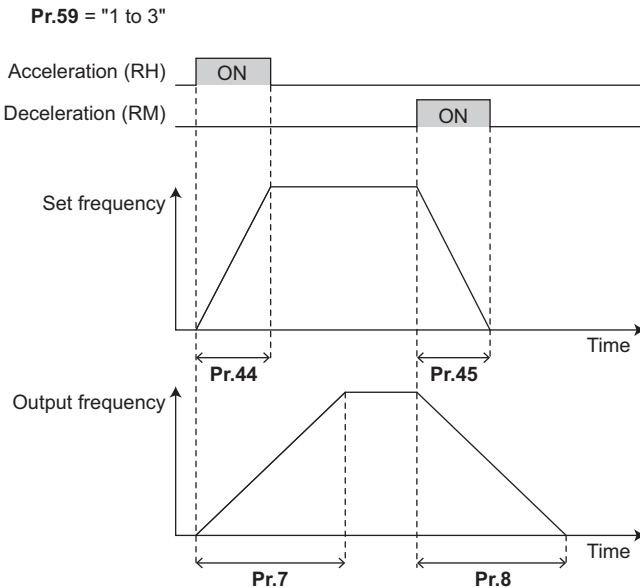

NOTE

- If the time setting of the output frequency is longer than the time setting of the set frequency, the motor accelerates/decelerates according to the time setting of the output frequency.

- Regardless of whether the remote setting is enabled or disabled, the acceleration/deceleration time set for the output frequency can be changed to the second acceleration/deceleration time by turning ON the RT signal.
- The acceleration/deceleration time setting of the set frequency is fixed at the Pr.44/Pr.45 setting.

◆ Frequency setting storage

- The remotely set frequency is stored, held, or cleared according to the **Pr.59** setting. When the inverter is turned ON again and the operation is resumed, the setting shown in the parentheses will be applied.

Pr.59 setting	Power OFF	STF/STR signal OFF
1	Stored (stored frequency)	Held (stored frequency)
2, 4	Cleared (main speed)	Held (stored frequency)
3	Cleared (main speed)	Cleared (main speed)

Storage conditions

The remotely-set frequency is stored at the point when the start signal (STF or STR) turns OFF. The remotely-set frequency is stored every minute after turning OFF (ON) the RH and RM signals together. Every minute, the frequency is overwritten in the EEPROM if the latest frequency is different from the previous one when comparing the two. This cannot be written using the RL signal.

NOTE

- When switching the start signal from ON to OFF, or changing frequency by the RH or RM signal frequently, set the frequency setting value storage function (write to EEPROM) invalid (**Pr.59** = "2 to 4"). If the frequency setting value storage function is valid (**Pr.59** = "1"), the frequency is written to EEPROM frequently, and this will shorten the life of the EEPROM.
- The range of frequency changeable by acceleration (RH) signal, deceleration (RM) signal (when **Pr.59** = "1 to 3"), and the start signal (STF or STR) (when **Pr.59** = "4") is 0 to maximum frequency (**Pr.1** or **Pr.18** setting). Note that the maximum value of set frequency is equal to the total of the main speed and the maximum frequency.

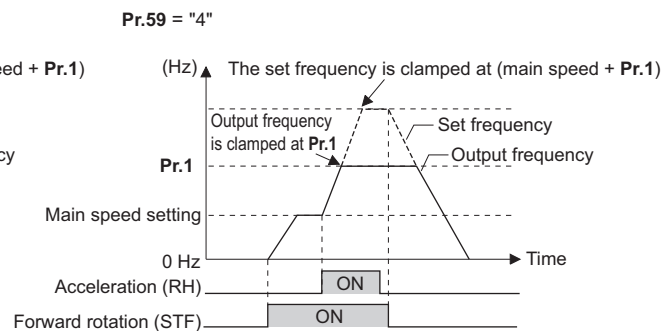
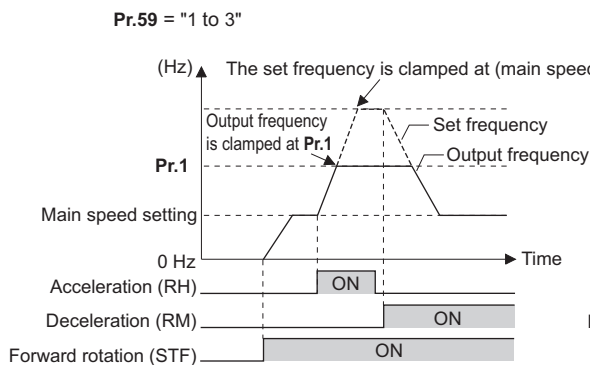

- Even if the start signal (STF or STR) is OFF, turning ON the RH or RM signal varies the preset frequency. (When **Pr.59** = "4", the RM signal is disabled.)
- The RH, RM, or RL signal can be assigned to an input terminal by setting **Pr.178 to Pr.182** and **Pr.185 to Pr.189** (**Input terminal function selection**). Changing the terminal assignment may affect other functions. Set parameters after confirming the function of each terminal.
- The inverter can be used in the Network operation mode.
- The remote setting function is invalid during JOG operation and PID control operation.
- The multi-speed operation function is invalid when remote setting function is selected.

When the setting frequency is "0"

- Even when the remotely-set frequency is cleared by turning ON the RL (clear) signal after turning OFF (ON) both the RH and RM signals, the inverter operates at the remotely-set frequency stored in the last operation if power is reapplied before one minute has elapsed since turning OFF (ON) both the RH and RM signals.

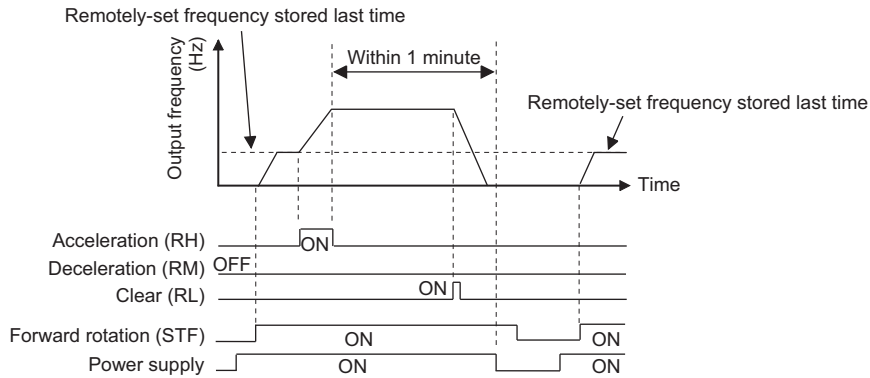

- When the remotely-set frequency is cleared by turning ON the RL (clear) signal after turning OFF (ON) both the RH and RM signals, the inverter operates at the frequency in the remotely-set frequency cleared state if power is reapplied before one minute has elapsed since turning OFF (ON) both the RH and RM signals.

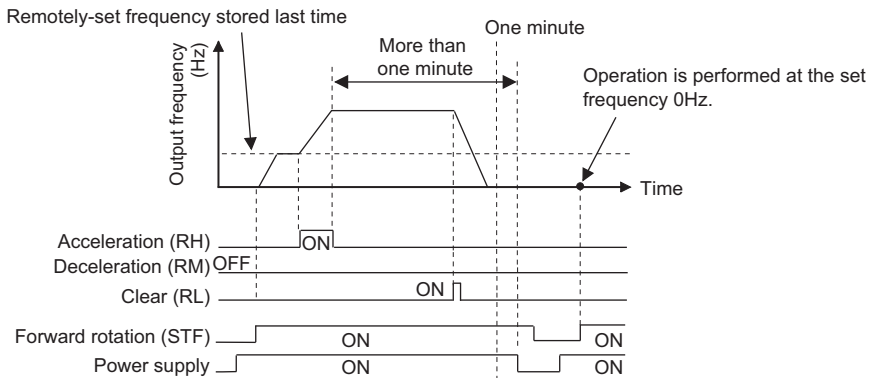

CAUTION

- When using the remote setting function, set the maximum frequency again according to the machine.

Parameters referred to

Pr.1 Maximum frequency, Pr.18 High speed maximum frequency [page 191](#)

Pr.7 Acceleration time, Pr.8 Deceleration time, Pr.44 Second acceleration/deceleration time, Pr.45 Second deceleration time [page 130](#)

Pr.178 to Pr.182 and Pr.185 to Pr.189 (Input terminal function selection) [page 252](#)

7.4 Starting frequency and start-time hold function



It is possible to set the starting frequency and hold the set starting frequency for a certain period of time. Set these functions when a starting torque is needed or the motor drive at start needs smoothing.

Pr.	Name	Initial value	Setting range	Description
13 F102	Starting frequency	0.5 Hz	0 to 60 Hz	Set the starting frequency at which the start signal is turned ON.
571 F103	Holding time at a start	9999	0 to 10 s	Set the holding time of the frequency set in Pr.13.
			9999	The holding function at start is disabled.

◆ Starting frequency setting (Pr.13)

- The frequency at start can be set in the range of 0 to 60 Hz.
- Set the starting frequency at which the start signal is turned ON.

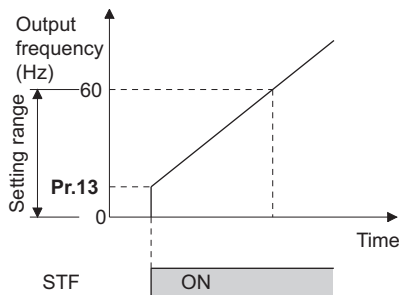

NOTE

- The inverter does not start if the frequency setting signal has a value lower than that of Pr.13. For example, while Pr.13 = 5 Hz, the inverter output starts when the frequency setting signal reaches 5 Hz.

◆ Start-time hold function (Pr.571)

- This function holds during the period set in Pr.571 and the output frequency set in Pr.13 Starting frequency.
- This function performs initial excitation to smooth the motor drive at a start.

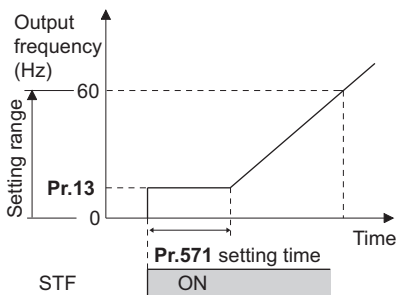

NOTE

- When Pr.13 = 0 Hz, the starting frequency is held at 0.01 Hz.
- When the start signal was turned OFF during start-time hold, deceleration is started at that point.
- At switching between forward rotation and reverse rotation, the starting frequency is valid but the start-time hold function is disabled.

⚠ CAUTION

- Note that when Pr.13 is set to a value equal to or lower than Pr.2 Minimum frequency, simply turning ON the start signal runs the motor at the frequency set in Pr.2 even if the command frequency is not given.

«Parameters referred to»

Pr.2 Minimum frequency  [page 191](#)

7.5 Minimum motor speed frequency at the motor start up



Set the frequency where the PM motor starts running.

Set the deadband in the low-speed range to eliminate noise and offset deviation when setting a frequency with analog input.

Pr.	Name	Initial value	Setting range	Description
13 F102	Starting frequency	Minimum frequency / minimum rotations per minute	0 to 60 Hz	Set the frequency where the motor starts running.

◆ Starting frequency setting (Pr.13)

- The frequency where the PM motor starts running can be set in the range of 0 to 60 Hz.
- When the frequency command specifies the frequency less than the one set in **Pr.13 Starting frequency**, the motor is stopped.
- When the frequency command specifies the frequency equal to the set frequency or higher, the PM motor accelerates according to the setting of **Pr.7 Acceleration time**.

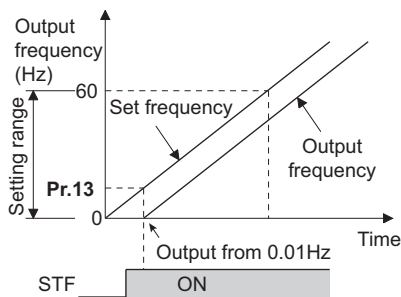

NOTE

- Under induction motor control (under V/F control or Advanced magnetic flux vector control), the output starts at the frequency set in **Pr.13**. Under PM sensorless vector control, the output always starts at 0.01 Hz.
- The inverter does not start if the frequency setting signal has a value lower than that of **Pr.13**. For example, while **Pr.13** = 20 Hz, the inverter output starts when the frequency setting signal reaches 20 Hz.

CAUTION

- Note that when **Pr.13** is set to a value equal to or lower than **Pr.2 Minimum frequency**, simply turning ON the start signal runs the motor at the frequency set in **Pr.2** even if the command frequency is not given.

Parameters referred to

Pr.2 Minimum frequency [page 191](#)

Pr.7 Acceleration time [page 130](#)

8 (D) Operation Command and Frequency Command

Purpose	Parameter to set			Refer to page
To select the operation mode	Operation mode selection	P.D000	Pr.79	142
To start up the inverter in Network operation mode at power-ON	Communication startup mode selection	P.D000, P.D001	Pr.79, Pr.340	152
To select the command source during communication operation	Operation and speed command sources during communication operation, command source selection	P.D010, P.D011, P.D013	Pr.338, Pr.339, Pr.551	153
To prevent the motor from rotating reversely	Reverse rotation prevention selection	P.D020	Pr.78	158
To change the setting resolution of the torque limit	Set resolution switchover	P.D030	Pr.811	206
To set the frequency using pulse train input	Pulse train input	P.D100, P.D101, P.D110, P.D111	Pr.291, Pr.384 to Pr.386	159
To perform JOG (inching) operation	JOG operation	P.D200, P.F002	Pr.15, Pr.16	161
To control the frequency with combinations of terminals	Multi-speed operation	P.D301 to P.D315	Pr.4 to Pr.6, Pr.24 to Pr.27, Pr.232 to Pr.239	163

8.1 Operation mode selection

Select the operation mode of the inverter.

The mode can be changed among operation using external signals (External operation), operation by the operation panel or parameter unit (PU operation), combined operation of PU operation and External operation (External/PU combined operation), and Network operation (via RS-485 communication).

Pr.	Name	Initial value	Setting range	Description
79 D000	Operation mode selection	0	0 to 4, 6, 7	Selects the operation mode.

The following table lists valid and invalid commands in each operation mode.

Pr.79 setting	Description			LED indicator		Refer to page
				■: OFF		
				□: ON		
0 (initial value)	PU/EXT key selection of the operation mode. The inverter operation mode can be selected by pressing the HAND/AUTO key. At power ON, the inverter is in the External operation mode.			PU operation mode 	146	
1	Operation mode	Frequency command	Start command	PU operation mode 	146	
	Fixed at PU operation mode.	Sent from the operation panel or parameter unit.	Input using the RUN key on the operation panel or the FWD/REV key on the parameter unit			
2	Fixed at External operation mode. However, the inverter operation mode can also be changed to the Network operation mode.	Sent using external signals (input via terminal 2 or 4, using the JOG signal, using the multi-speed setting function, etc.).	Sent using external signals (via terminal STF or STR).	External operation mode NET operation mode 	146	
3	External/PU combined operation mode 1	Sent from the operation panel or parameter unit, or sent using external signals (input using the multi-speed setting function or via terminal 4). ^{*1}	Sent using external signals (via terminal STF or STR).	External/PU combined operation mode 	146	
4	External/PU combined operation mode 2	Sent using external signals (input via terminal 2 or 4, using the JOG signal, using the multi-speed setting function, etc.).	Input using the RUN key on the operation panel or the FWD/REV key on the parameter unit		147	
6	Operation mode switchover during operation. Switching from among the PU, External, and NET operation modes can be performed during operation.			PU operation mode 	147	
7	External operation mode (PU operation interlock) X12 signal ON: Switchover to PU operation mode enabled (signal is OFF during External operation). X12 signal OFF: Switchover to PU operation mode disabled			External operation mode NET operation mode 	148	

*1 The following is the frequency commands listed in descending order of priority when "3" is set in Pr.79: Multi-speed setting function (RL/RM/RH/REX signal) > PID control (X14 signal) > terminal 4 analog input (AU signal) > set frequency (digital input from the PU).

◆ Operation mode basics

- The operation mode specifies the source of the start command and the frequency command for the inverter.
- Basic operation modes are as follows.

External operation mode : For giving a start command and a frequency command with an external potentiometer or switches which are connected to the control circuit terminal.

PU operation mode : For giving a start command and a frequency command with the operation panel or parameter unit.

Network operation mode (NET operation mode) : For giving a start command and a frequency command via RS-485 communication.

- The operation mode can be selected from the operation panel or with the communication instruction code.

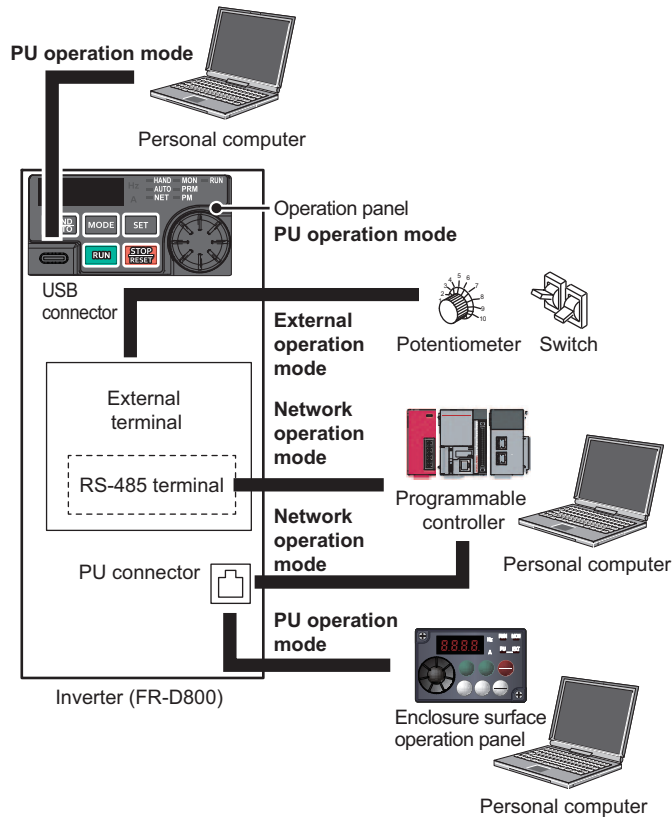

NOTE

- There is a choice of two settings, "3" and "4", for the External/PU combined operation mode. The startup method differs according to the setting value.
- In the initial setting, the PU stop selection (function to stop the inverter operation by pressing the STOP/RESET key on the operation panel or the parameter unit) is enabled even in the operation mode other than the PU operation mode. (Refer to [page 97.](#))

◆ Operation mode switching method

When "0 or 1" is set in Pr.340

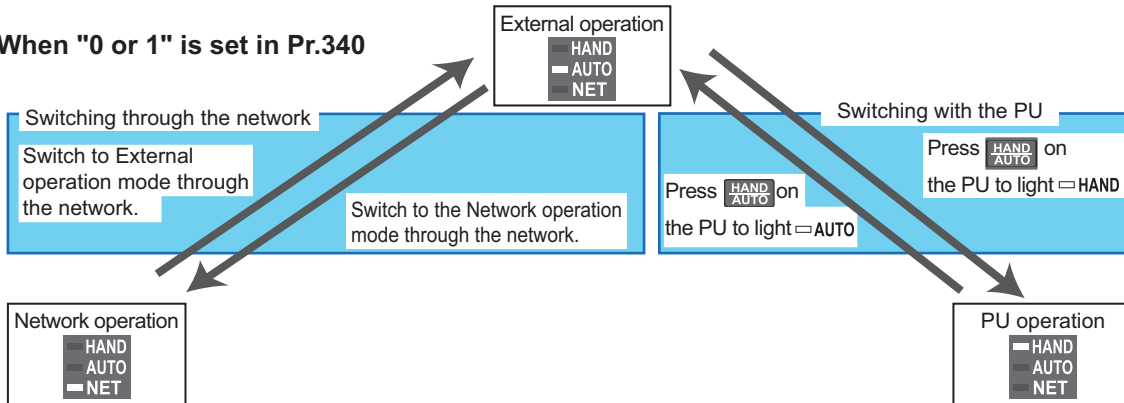

When "10" is set in Pr.340

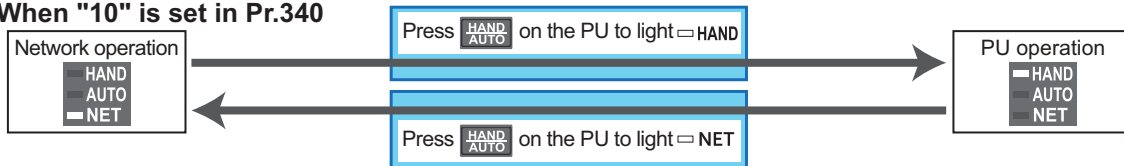

NOTE

- For details on switching by external terminals, refer to the following pages.

PU operation external interlock (X12 signal) [page 148](#)

PU/External operation switchover (X16 signal) [page 149](#)

PU/NET operation switchover (X65 signal), External/NET operation switchover (X66 signal) [page 150](#)

Pr.340 Communication startup mode selection [page 152](#)

◆ Operation mode selection flow

Referring to the following table, select the basic parameter settings or terminal wiring related to the operation mode.

Method to give start command	Method to give frequency setting command	Parameter setting	Operation method	
			Start command	Frequency setting
External signals (via terminal STF/STR)	External signals (input via terminal 2 or 4, using the JOG signal, using the multi-speed setting function, etc.)	Pr.79 = "2" (Fixed at External operation mode)	Turn ON terminal STF/STR.	Turn ON a terminal used for frequency setting.
	Operation panel or parameter unit	Pr.79 = "3" (External/PU combined operation mode 1)	Turn ON terminal STF/STR.	Digital setting
	USB connector	Pr.79 = "3" (External/PU combined operation mode 1)	Turn ON terminal STF/STR.	Digital setting
	Communication (PU connector / RS-485 terminal)	Pr.338 = "1" Pr.340 = "1"	Turn ON terminal STF/STR.	Transmit a frequency command via communication.
Operation panel (RUN key) or parameter unit (FWD/REV key)	External signals (input via terminal 2 or 4, using the JOG signal, using the multi-speed setting function, etc.)	Pr.79 = "4" (External/PU combined operation mode 2)	Press the RUN key. Press the FWD/REV key.	Turn ON a terminal used for frequency setting.
	Operation panel or parameter unit	Pr.79 = "1" (Fixed at PU operation mode)	Press the RUN key. Press the FWD/REV key.	Digital setting
	• USB connector • Communication (PU connector / RS-485 terminal)	Not available		
Communication (PU connector / RS-485 terminal)	External signals (input via terminal 2 or 4, using the JOG signal, using the multi-speed setting function, etc.)	Pr.339 = "1" Pr.340 = "1"	Transmit a start command via communication	Turn ON a terminal used for frequency setting.
	USB connector	Not available		
	Communication (PU connector / RS-485 terminal)	Pr.340 = "1"	Transmit a start command via communication	Transmit a frequency command via communication.

◆ External operation mode (Pr.79 = "0 (initial value) or 2")

- Select the External operation mode when the start command and the frequency command are applied from a frequency setting potentiometer, start switch, etc. which are provided externally and connected to the control circuit terminals of the inverter.
- Generally, parameter change cannot be performed in the External operation mode. (Some parameters can be changed. Refer to [page 109](#).)
- When **Pr.79** = "0 or 2", the inverter starts up in the External operation mode at power-ON. (When using the Network operation mode, refer to [page 152](#).)
- When parameter changing is seldom necessary, setting "2" fixes the operation mode to the External operation mode. When frequent parameter changing is necessary, setting "0 (initial value)" allows the operation mode to be changed easily to the PU operation mode by pressing the HAND/AUTO key on the operation panel. After switching to the PU operation mode, always return to the External operation mode.
- The STF or STR signal is used as a start command. The input voltage or current via terminal 2 or 4, multi-speed setting signal, or JOG signal is used as a frequency command.

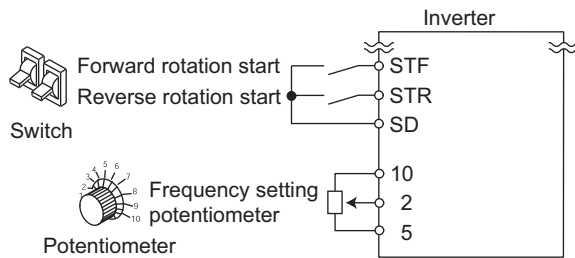

◆ PU operation mode (Pr.79 = "1")

- Select the PU operation mode when giving start and frequency commands by only the key operation of the operation panel or the parameter unit.
- When **Pr.79** = "1", the inverter starts up in the PU operation mode at power-ON. The mode cannot be changed to other operation modes.

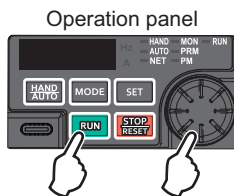

◆ PU/External combined operation mode 1 (Pr.79 = "3")

- Select the PU/External combined operation mode 1 when giving a frequency command from the operation panel or the parameter unit and giving a start command with the external start switches.
- Set "3" in **Pr.79**. The mode cannot be changed to other operation modes.
- When the frequency commands are given using the multi-speed setting signals (external signals), they have a higher priority than the frequency commands given from the PU. When the AU signal is ON, inputting the command signals via terminal 4 is enabled.

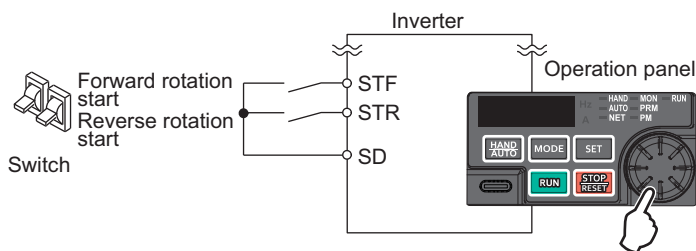

◆ PU/External combined operation mode 2 (Pr.79 = "4")

- Select the PU/External combined operation mode 2 when giving a frequency command from the external potentiometer, or multi-speed and JOG signals, and giving a start command by key operation of the operation panel or the parameter unit.
- Set "4" in Pr.79. The mode cannot be changed to other operation modes.

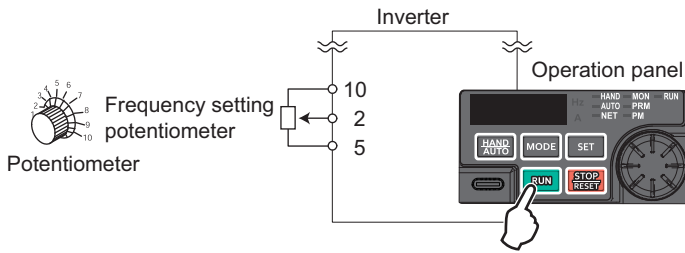

◆ Operation mode switchover during operation (Pr.79 = "6")

- During operation, the inverter operation mode can be switched from among the PU, External, and Network (Network operation mode is selectable via RS-485 communication).

Operation mode switchover	Operation/operating status
External operation→PU operation	Use the operation panel or parameter unit to change the operation mode to the PU operation mode. <ul style="list-style-type: none"> • The direction of motor rotation does not change due to the operation mode change from the External operation mode. • The previous setting of frequency which has been set using a potentiometer (frequency command) is taken over. (However, note that the setting disappears when the power is turned OFF or when the inverter is reset.)
External operation→NET operation	Give the command through communication to change the operation mode to the Network operation mode. <ul style="list-style-type: none"> • The direction of motor rotation does not change due to the operation mode change from the External operation mode. • The previous setting of frequency which has been set using a potentiometer (frequency command) is taken over. (However, note that the setting disappears when the power is turned OFF or when the inverter is reset.)
PU operation→External operation	Press the key on the operation panel or parameter unit to change the operation mode to the External operation mode. <ul style="list-style-type: none"> • The direction of operation is determined by external input signals used in the External operation mode. • The setting frequency is determined by the external frequency command signal.
PU operation→NET operation	Give the command through communication to change the operation mode to the Network operation mode. <ul style="list-style-type: none"> • The direction of motor rotation and the frequency setting do not change due to the operation mode change from the PU operation mode.
NET operation→External operation	Give the command through communication to change the operation mode to the External operation mode. <ul style="list-style-type: none"> • The direction of operation is determined by external input signals used in the External operation mode. • The setting frequency is determined by the external frequency command signal.
NET operation→PU operation	Use the operation panel or parameter unit to change the operation mode to the PU operation mode. <ul style="list-style-type: none"> • The direction of motor rotation and the frequency setting do not change due to the operation mode change from the Network operation mode.

◆ PU operation interlock (Pr.79 = "7")

- The operation mode can be forcibly switched to the External operation mode by turning OFF the PU operation external interlock (X12) signal. This function will be usable in a case where the inverter does not reply to external command signals during operation due to the operation mode accidentally unswitched from the PU operation mode to the External operation mode.
- To input the X12 signal, set "12" in any parameter from **Pr.178 to Pr.182 (Input terminal function selection)** to assign the function.
(For details on **Pr.178 to Pr.182**, refer to [page 252](#).)
- Set **Pr.79 = "7"** (PU operation interlock).
- If the X12 signal is not assigned, the function of the MRS signal is switched to the PU operation interlock signal from MRS (output stop).

X12 (MRS) signal	Function/Operation	
	Operation mode	Parameter writing ^{*1}
ON	Switching of the operation mode (External, PU, and NET) is enabled. The signal is OFF during External operation.	Enabled.
OFF	Operation mode is forcefully changed to the External operation mode. External operation is enabled. Switching to the PU or NET operation mode from the External operation mode is disabled.	Disabled except for Pr.79 .

*1 Depends on the **Pr.77 Parameter write selection** setting and other parameter write conditions. (Refer to [page 109](#).)

- Functions/operations by X12 (MRS) signal ON/OFF

Operating status		X12 (MRS) signal	Operation mode	Operating status	Switching to PU or NET operation mode
Operation mode	Status				
PU/NET	During stop	ON→OFF ^{*1}	External ^{*2}	If frequency and start commands are given from external source, the inverter runs by those commands.	Disabled
	During running	ON→OFF ^{*1}			Disabled
External	During stop	OFF→ON	External ^{*2}	During stop	Enabled
		ON→OFF			Disabled
	During running	OFF→ON		Running→Output stop	Disabled
		ON→OFF		Output stop→Running	Disabled

*1 The mode is switched to the External operation mode regardless of the ON/OFF state of the start signal (STF/STR). Thus, the motor runs under the External operation mode when the X12 (MRS) signal turns OFF while the STF or STR signal is ON.

*2 When a fault occurs, the inverter can be reset by pressing the STOP/RESET key on the operation panel.

NOTE

- The operation mode cannot be switched to the PU operation mode with the start signal (STF/STR) ON state even if the X12 (MRS) signal turns ON.
- If the MRS signal is ON and **Pr.79** is written to a value other than "7" when the MRS signal is used as the PU interlock signal, the MRS signal will perform a regular MRS function (output stop). Also, when **Pr.79 = "7"**, the signal becomes the PU interlock signal.
- The logic of the signal follows the **Pr.17 MRS/X10 terminal input selection** setting also when the MRS signal is used as the PU operation interlock signal. When **Pr.17 = "2 to 5"**, ON and OFF in the table above are reversed.
- Changing the terminal assignment using **Pr.178 to Pr.182 and Pr.185 to Pr.189 (Input terminal function selection)** may affect the other functions. Set parameters after confirming the function of each terminal.

◆ Switching operation mode by external signal (X16 signal)

- When External operation and the operation from the operation panel are used together, the PU operation mode and External operation mode can be switched during a stop (during motor stop, start command OFF) by using the PU/External operation switchover (X16) signal.
- When **Pr.79** = "0, 6, or 7", switching between the PU operation mode and External operation mode is possible. (When **Pr.79** = "6", switchover is enabled during operation.)
- To input the X16 signal, set "16" in any parameter from **Pr.178 to Pr.182 (Input terminal function selection)** to assign the function.

Pr.79 setting		X16 signal status and operation mode		Remarks
		ON (External)	OFF (PU)	
0 (initial value)		External operation mode	PU operation mode	Switching among the External, PU, and NET operation modes is enabled.
1		PU operation mode		Fixed at PU operation mode.
2		External operation mode		Fixed at External operation mode (Switching to NET operation mode enabled).
3, 4		External/PU combined operation mode		Fixed at External/PU combined operation mode.
6		External operation mode	PU operation mode	Switching among the External, PU, and NET operation mode is enabled during operation.
7	X12 (MRS) ON	External operation mode	PU operation mode	Switching among the External, PU, and NET operation mode is enabled (signal is OFF in the External operation mode).
	X12 (MRS) OFF	External operation mode		Fixed at External operation mode (forcibly switched to External operation mode).

NOTE

- The operation mode is determined by the setting of **Pr.340 Communication startup mode selection** and the ON/OFF state of the X65 and X66 signals. (For the details, refer to [page 150](#).)
- The priority of **Pr.79** and **Pr.340** and signals is **Pr.79** > X12 > X66 > X65 > X16 > **Pr.340**.
- Changing the terminal assignment using **Pr.178 to Pr.182 and Pr.185 to Pr.189 (Input terminal function selection)** may affect the other functions. Set parameters after confirming the function of each terminal.

◆ Switching the operation mode by external signals (X65, X66 signals)

- When **Pr.79** = "0, 2, 6, or 7", the PU operation mode and External operation mode can be changed to the Network operation mode during a stop (during motor stop, start command OFF) by the PU/NET operation switchover (X65) signal, or the External/NET operation switchover (X66) signal. (When **Pr.79** = "6", switchover is enabled during operation.)
- To switch between the Network operation mode and the PU operation mode

- Set **Pr.79** = "0 (initial value) or 6".
- Set **Pr.340 Communication startup mode selection** = "10".
- Set "65" in any parameter from **Pr.178 to Pr.182** to assign the PU/NET operation switchover (X65) signal to a terminal.
- When the X65 signal is ON, the PU operation mode is selected. When the X65 signal is OFF, the NET operation mode is selected.

Pr.340 setting	Pr.79 setting	X65 signal state		Remarks	
		ON (PU)	OFF (NET)		
10	0 (initial value)	PU operation mode	NET operation mode	—	
	1	PU operation mode		Fixed at PU operation mode.	
	2	NET operation mode		Fixed at NET operation mode.	
	3, 4	External/PU combined operation mode		Fixed at External/PU combined operation mode.	
	6	PU operation mode	NET operation mode	The operation mode can be changed during operation.	
	7	X12 (MRS) ON	Switching between the External operation mode and PU operation mode is enabled.		The signal is OFF during operation in the External operation mode.
		X12 (MRS) OFF	External operation mode		The operation mode is forcibly switched to the External operation mode.

- To switch between the Network operation mode and the External operation mode
- Set **Pr.79** = "0 (initial value), 2, 6, or 7". (When **Pr.79** = "7" and the X12 (MRS) signal is ON, the operation mode can be switched.)
 - Set **Pr.340 Communication startup mode selection** = "0 (initial value) or 1".
 - Set "66" in any parameter from **Pr.178 to Pr.182** to assign the External/NET operation switchover (X66) signal to a terminal.
 - When the X66 signal is ON, the NET operation mode is selected. When the X66 signal is OFF, the External operation mode is selected.

Pr.340 setting	Pr.79 setting	X66 signal state		Remarks	
		ON (NET)	OFF (External)		
0 (initial value), 1	0 (initial value)	NET operation mode	External operation mode	—	
	1	PU operation mode		Fixed at PU operation mode.	
	2	NET operation mode	External operation mode	Switching to PU operation mode is disabled.	
	3, 4	External/PU combined operation mode		Fixed at External/PU combined operation mode.	
	6	NET operation mode	External operation mode	The operation mode can be changed during operation.	
	7	X12 (MRS) ON	NET operation mode	External operation mode	The signal is OFF during operation in the External operation mode.
		X12 (MRS) OFF	External operation mode		The operation mode is forcibly switched to the External operation mode.

NOTE

- The priority of **Pr.79** and **Pr.340** and signals is **Pr.79 > X12 > X66 > X65 > X16 > Pr.340**.
- Changing the terminal assignment using **Pr.178 to Pr.182** and **Pr.185 to Pr.189 (Input terminal function selection)** may affect the other functions. Set parameters after confirming the function of each terminal.

«Parameters referred to»

Pr.15 Jog frequency  [page 161](#)

Pr.4 to Pr.6, Pr.24 to Pr.27, Pr.232 to Pr.239 Multi-speed operation  [page 163](#)

Pr.75 Reset selection/disconnected PU detection/PU stop selection  [page 97](#)

Pr.161 Frequency setting/key lock operation selection  [page 104](#)

Pr.178 to Pr.182 and Pr.185 to Pr.189 (Input terminal function selection)  [page 252](#)

Pr.340 Communication startup mode selection  [page 152](#)

8.2 Startup of the inverter in Network operation mode at power-ON

The operation mode at power ON and at restoration from instantaneous power failure can be selected.

After the inverter starts up in the Network operation mode, parameter writing and operation can be commanded from programs.

Set this mode when performing communication operation using the PU connector or RS-485 terminals.

Pr.	Name	Initial value	Setting range	Description
79 D000	Operation mode selection	0	0 to 4, 6, 7	Selects the operation mode. (Refer to page 142 .)
340 D001	Communication startup mode selection	0	0	The inverter starts up in an operation mode selected in Pr.79 .
			1	The inverter starts up in the Network operation mode.
			10	The inverter starts up in the Network operation mode. The operation mode can be changed on the operation panel between the PU operation mode and Network operation mode.

◆ Selecting the operation mode for power-ON (Pr.340)

- Depending on the **Pr.79** and **Pr.340** settings, the operation mode at power-ON (reset) changes as described below.

Pr.340 setting	Pr.79 setting	Operation mode at power-ON, at power restoration, or after a reset	Operation mode switching	
0 (initial value)	0 (initial value)	External operation mode	Switching among the External, PU, and NET operation modes is enabled ^{*1}	
	1	PU operation mode	Fixed at PU operation mode.	
	2	External operation mode	Switching between the External and NET operation modes is enabled. Switching to PU operation mode is disabled.	
	3, 4	External/PU combined operation mode	Operation mode switching is disabled.	
	6	External operation mode	Switching among the External, PU, and NET operation mode is enabled during operation.	
	7	X12 (MRS) signal ON: External operation mode	Switching among the External, PU, and NET operation modes is enabled ^{*1}	
		X12 (MRS) signal OFF: External operation mode	Fixed at External operation mode (forcibly switched to External operation mode).	
1	0	NET operation mode	Same as Pr.340 = "0".	
	1	PU operation mode		
	2	NET operation mode		
	3, 4	External/PU combined operation mode		
	6	NET operation mode		
	7	X12 (MRS) signal ON: NET operation mode		
		X12 (MRS) signal OFF: External operation mode		
10	0	NET operation mode	Switching between the PU and NET operation mode is enabled. ^{*2}	
	1	PU operation mode	Same as Pr.340 = "0".	
	2	NET operation mode	Fixed at NET operation mode.	
	3, 4	External/PU combined operation mode	Same as Pr.340 = "0".	
	6	NET operation mode	Switching between the PU and NET operation mode is enabled while running. ^{*2}	
	7	External operation mode	Same as Pr.340 = "0".	

*1 The operation mode cannot be directly changed between the PU operation mode and Network operation mode.

*2 Switching between the PU and NET operation modes is available with the HAND/AUTO key on the operation panel and the X65 signal.

« Parameters referred to »

Pr.57 Restart coasting time  [page 307](#), [page 312](#)

Pr.79 Operation mode selection  [page 142](#)

8.3 Start command source and frequency command source during communication operation

The start and frequency commands can be given via communication using the external signals. The command source in the PU operation mode can also be selected.

Pr.	Name	Initial value	Setting range	Description
338 D010	Communication operation command source	0	0	Start command source is communication.
			1	Start command source is external.
339 D011	Communication speed command source	0	0	Frequency command source is communication.
			1	Frequency command source is external.
			2	Frequency command source is external. (When there is no external input, the frequency command given via communication is valid, and the frequency command given via terminal 2 is invalid.)
551 D013	PU mode operation command source selection	9999	2	The PU connector is the command source in the PU operation mode.
			3	The USB connector is the command source in the PU operation mode.
			4	The operation panel is the command source in the PU operation mode.
			9999	The USB is recognized automatically. Normally, the operation panel is the command source. When the USB is connected, the USB connector is the command source.

◆ Selection of the command source of the PU operation mode (Pr.551)

- Any of the PU connector, operation panel, or USB connector can be specified for the command source in the PU operation mode.
- Set **Pr.551** to write parameters or execute the start and frequency commands through communication in the PU operation mode: **Pr.551** = "2" when using the PU connector, **Pr.551** = "3" or "9999" when using the USB connector, and **Pr.551** = "4" when using the operation panel.

NOTE

- The changed value is applied after the next power-ON or inverter reset.

Pr.551 setting	Command source			
	Operation panel	USB connector	PU connector	
			Operation option ^{*1}	RS-485 communication
2	x	x	PU	PU ^{*2}
3	x	PU	x	x
4	PU	x	x	x
9999 (initial value)	PU ^{*3}	PU ^{*3}	PU ^{*3}	x

PU: Enabled in PU operation mode, x: Not available

*1 When the enclosure surface operation panel (FR-PA07) is used.

*2 The MODBUS RTU protocol cannot be used in the PU operation mode.

*3 When **Pr.551** = "9999", the priority of the PU command source is defined as follows: USB connector > PU connector > operation panel.

◆ Controllability through communication

Command interface	Condition	Item	Controllability in each operation mode				
			PU operation	External operation	Combined operation mode 1 (Pr.79 = "3")	Combined operation mode 2 (Pr.79 = "4")	NET operation (via PU connector / RS-485 terminal)
Operation panel	Pr.551 = "4" or Pr.551 = "9999" (USB / PU connector is not connected)	Operation command (start, stop)	○	Δ ^{*3}	Δ ^{*3}	○	Δ ^{*3}
		Frequency setting	○	×	○	×	×
		Monitor	○	○	○	○	○
		Parameter write	○ ^{*5}	×	○ ^{*5}	○ ^{*5}	×
		Parameter read	○	○	○	○	○
		Inverter reset	×	×	×	×	×
	Other than the above	Operation command (start, stop)	Δ ^{*3}	Δ ^{*3}	Δ ^{*3}	Δ ^{*3}	Δ ^{*3}
		Frequency setting	×	×	×	×	×
		Monitor	○	○	○	○	○
		Parameter write	×	×	×	×	×
		Parameter read	○	○	○	○	○
		Inverter reset	×	×	×	×	×
PU connector (operation option) ^{*1}	Pr.551 = "2" or Pr.551 = "9999" (USB is not connected)	Operation command (start, stop)	○	Δ ^{*3}	Δ ^{*3}	○	—
		Frequency setting	○	×	○	○	—
		Monitor	○	○	○	○	○
		Parameter write	○ ^{*5}	×	○ ^{*5}	○ ^{*5}	—
		Parameter read	○	○	○	○	○
		Inverter reset	○	○	○	○	—
	Other than the above	Operation command (start, stop)	Δ ^{*3}	Δ ^{*3}	Δ ^{*3}	Δ ^{*3}	Δ ^{*3}
		Frequency setting	×	×	×	×	×
		Monitor	○	○	○	○	○
		Parameter write	×	×	×	×	×
		Parameter read	○	○	○	○	○
		Inverter reset	○	○	○	○	○
PU connector / RS-485 terminals (RS-485) ^{*2}	Pr.551 = "2" (PU)	Operation command (start, stop)	○	Δ ^{*3}	Δ ^{*3}	○	—
		Frequency setting	○	×	○	○	—
		Monitor	○	○	○	○	○
		Parameter write	○ ^{*5}	×	○ ^{*5}	○ ^{*5}	—
		Parameter read	○	○	○	○	○
		Inverter reset	○	○	○	○	—
	Other than the above	Operation command (start, stop)	×	×	×	×	○ ^{*4}
		Frequency setting	×	×	×	×	○ ^{*4}
		Monitor	○	○	○	○	○
		Parameter write	×	×	×	×	○ ^{*5}
		Parameter read	○	○	○	○	○
		Inverter reset	×	×	×	×	○

Command interface	Condition	Item	Controllability in each operation mode				
			PU operation	External operation	Combined operation mode 1 (Pr.79 = "3")	Combined operation mode 2 (Pr.79 = "4")	NET operation (via PU connector / RS-485 terminal)
USB connector	Pr.551 = "3, 9999"	Operation command (start, stop)	○	×	×	○	×
		Frequency setting	○	×	○	○	×
		Monitor	○	○	○	○	○
		Parameter write	○ ^{*5}	×	○ ^{*5}	○ ^{*5}	×
		Parameter read	○	○	○	○	○
		Inverter reset	○	○	○	○	○
	Other than the above	Operation command (start, stop)	×	×	×	×	×
		Frequency setting	×	×	×	×	×
		Monitor	○	○	○	○	○
		Parameter write	×	×	×	×	×
		Parameter read	○	○	○	○	○
		Inverter reset	○	○	○	○	○
External control circuit terminal	—	Operation command (start, stop)	×	○	○	×	×
		Frequency setting	×	○	△ ^{*8}	○	×
		Inverter reset	○	○	○	○	○

○: Controllable, ×: Uncontrollable, △: Partially controllable, —: No function

*1 Operation when the enclosure surface operation panel (FR-PA07) is used.

*2 RS-485 communication via PU connector or RS-485 terminals.

*3 Only the PU stop function is enabled. "PS" is displayed on the operation panel during PU stop. The operation follows the **Pr.75 Reset selection/disconnected PU detection/PU stop selection** setting. (Refer to [page 97](#).)

*4 The operation follows the **Pr.338 Communication operation command source** and **Pr.339 Communication speed command source** settings. (Refer to [page 153](#).)

*5 Writing of some parameters may be disabled by the **Pr.77 Parameter write selection** setting and the operating condition. (Refer to [page 109](#).)

*6 Some parameters are write-enabled regardless of the operation mode or the command source. Writing is also enabled when **Pr.77 = "2"**. (Refer to [page 109](#).) Parameter clear is disabled.

*7 When a fault occurs, the inverter can be reset by pressing the STOP/RESET key on the operation panel.

*8 The inverter can be reset by using the multi-speed operation function and analog input (terminal 4).

◆ Operation when a communication error occurs

Fault type	Condition	Operation in each operation mode at error occurrences				
		PU operation	External operation	Combined operation mode 1 (Pr.79 = "3")	Combined operation mode 2 (Pr.79 = "4")	NET operation (via PU connector / RS-485 terminals)
Inverter fault	—	Stop				
PU connector disconnection	Pr.551 = "2" or Pr.551 = "9999" (USB is not connected / PU connector is connected)	Stop/continued ^{*1*3}				
	Other than the above	Stop/continued ^{*1}				
Communication error at PU connector / RS-485 terminals	Pr.551 = "2"	Stop/continued ^{*2}	Continued		Stop/continued ^{*2}	—
	Other than the above	Continued				Stop/continued ^{*2}
Communication error at USB connector	Pr.551 = "3" or Pr.551 = "9999" (USB is connected)	Stop/continued ^{*2}	Continued		Stop/continued ^{*2}	Continued
	Other than the above	Continued				

*1 Selectable with **Pr.75 Reset selection/disconnected PU detection/PU stop selection**.

*2 Selectable with **Pr.122 RS-485 communication check time interval** and **Pr.548 USB communication check time interval**.

*3 In the PU JOG operation mode, operation always stops when the PU is disconnected. The operation at a PU disconnection fault (E.PUE) occurrence is as set in **Pr.75 Reset selection/disconnected PU detection/PU stop selection**.

◆ Selecting the command interface in the Network operation mode (Pr.338, Pr.339)

- Selecting a command interface is required for the following two types of commands: the operation command using the start signals and the signals related to the inverter function selection, and the speed command using signals related to the frequency setting.
- The following table shows the command interface for each function in the Network operation mode, determined by the parameter settings: an external terminal or a communication interface (PU connector or RS-485 terminals).

[Explanation of Terms in Table]

EXT: External terminal only

NET: Communication interface only

Combined: Either external terminal or communication interface

—: Neither external terminal nor communication interface

Pr.338 Communication operation command source		0: NET			1: EXT			Remarks
Pr.339 Communication speed command source		0: NET	1: EXT	2: EXT	0: NET	1: EXT	2: EXT	
Frequency setting through communication		NET	—	NET	NET	—	NET	
Terminal 2		—	EXT	—	—	EXT	—	
Terminal 4		—	EXT	—	—	EXT	—	
RL ^{*1}	Low-speed operation command/Remote setting (setting clear)	NET	EXT	—	NET	EXT	—	Pr.59 = "0" (multi-speed) Pr.59 ≠ "0" (remote)
RM ^{*1}	Middle-speed operation command/Remote setting (deceleration)	NET	EXT	—	NET	EXT	—	
RH ^{*1}	High-speed operation command/Remote setting (acceleration)	NET	EXT	—	NET	EXT	—	
RT ^{*1}	Second function selection	NET	—	—	EXT	—	—	
AU ^{*1}	Terminal 4 input selection	—	Combined	—	—	Combined	—	
JOG ^{*1}	Jog operation selection	—	—	—	EXT	—	—	
OH ^{*1}	External thermal relay input	EXT	—	—	—	—	—	
REX ^{*1}	15-speed selection	NET	EXT	—	NET	EXT	—	Pr.59 = "0" (multi-speed)
X10 ^{*1}	Inverter run enable	EXT	—	—	—	—	—	
X12 ^{*1}	PU operation external interlock	EXT	—	—	—	—	—	
X14 ^{*1}	PID control valid	NET	EXT	—	NET	EXT	—	
X16 ^{*1}	PU/External operation switchover	—	—	—	—	—	—	
X18 ^{*1}	V/F switchover	NET	—	—	EXT	—	—	
LX ^{*1}	Pre-excitation	NET	—	—	EXT	—	—	
MRS ^{*1}	Output stop	Combined	—	—	EXT	—	—	Pr.79 ≠ "7"
	PU operation interlock	EXT	—	—	—	—	—	Pr.79 = "7" When X12 signal is not assigned.
STOP ^{*1}	Start self-holding selection	—	—	—	EXT	—	—	
TL ^{*1}	Torque limit selection	NET	—	—	EXT	—	—	
JOG2 ^{*1}	Jog operation selection 2	NET	—	—	EXT	—	—	
X37 ^{*1}	Traverse function selection	NET	—	—	EXT	—	—	
TRG ^{*1}	Trace trigger input	Combined	—	—	EXT	—	—	
TRC ^{*1}	Trace sampling start/end	Combined	—	—	EXT	—	—	
STF ^{*1}	Forward rotation command	NET	—	—	EXT	—	—	
STR ^{*1}	Reverse rotation command	NET	—	—	EXT	—	—	
RES ^{*1}	Inverter reset	EXT	—	—	—	—	—	
X64 ^{*1}	PID forward/reverse action switchover	NET	EXT	—	NET	EXT	—	
X65 ^{*1}	PU/NET operation switchover	EXT	—	—	—	—	—	
X66 ^{*1}	External/NET operation switchover	EXT	—	—	—	—	—	
X67 ^{*1}	Command source switchover	EXT	—	—	—	—	—	
X72 ^{*1}	PID P control switchover	NET	EXT	—	NET	EXT	—	
X84 ^{*1}	Emergency drive execution command	Combined	—	—	—	—	—	

*1 Use Pr.178 to Pr.182 and Pr.185 to Pr.189 (Input terminal function selection) to assign the function to an input terminal. (Refer to page 252.)

NOTE

- The communication interface selection is determined by the setting of **Pr.551**.
- The settings of **Pr.338 and Pr.339** can be changed during operation when **Pr.77 = "2"**. Note that the changed setting is applied after the inverter has stopped. Until the inverter has stopped, the previous setting of the interface for the operation command and the speed command in the Network operation mode is valid.

◆ Changing the command interface using a signal input via external terminal (X67 signal)

- In the Network operation mode, the command interface for the operation command and the speed command can be changed using the Command source switchover (X67) signal. This method may be useful to use both external terminal and communication interface by using a different interface according to the command type.
- For the X67 signal, set "67" to any parameter from **Pr.178 to Pr.182 (Input terminal function selection)** to assign the function to a control circuit terminal.
- When the X67 signal is OFF, the command interface for the operation command and the speed command is the control circuit terminal.

X67 signal state	Interface for the operation command	Interface for the speed command
Signal not assigned	Determined by Pr.338 setting	Determined by Pr.339 setting
ON		
OFF	Control circuit terminal only	

NOTE

- The ON/OFF state of the X67 signal is applied only during a stop. When the terminals are switched during operation, the ON/OFF state is reflected after a stop.
- When the X67 is OFF, a reset via communication is disabled.
- Changing the terminal assignment using **Pr.178 to Pr.182 and Pr.185 to Pr.189 (Input terminal function selection)** may affect the other functions. Set parameters after confirming the function of each terminal.

Parameters referred to

Pr.59 Remote function selection  [page 135](#)

Pr.79 Operation mode selection  [page 142](#)

8.4 Reverse rotation prevention selection

This function can prevent reverse rotation fault resulting from the incorrect input of the start signal.

Pr.	Name	Initial value	Setting range	Description
78 D020	Reverse rotation prevention selection	0	0	Both forward and reverse rotations allowed
			1	Reverse rotation disabled
			2	Forward rotation disabled

- Set this parameter to limit the motor rotation to only one direction.
- This parameter is valid for all of the RUN key on the operation panel, FWD/REV key on the parameter unit, the start signals (STF, STR signals) via external terminals, and the forward and reverse rotation commands through communication.

8.5 Frequency setting using pulse train input

A pulse train input via terminal RM can be used to set the inverter's speed command.

Pr.	Name	Initial value ^{*1}		Setting range	Description
		Gr.1	Gr.2		
291 D100	Pulse train input selection	0		0	Terminal RM: RM signal ^{*2}
				1	Terminal RM: Pulse train input
384 D101	Input pulse division scaling factor	0		0	Pulse train input disabled
				1 to 250	Division ratio on the input pulse. The frequency resolution on the input pulse changes according to this setting.
385 D110	Frequency for zero input pulse	0 Hz		0 to 590 Hz	Set the frequency applicable to the time when the input pulse is zero (bias).
386 D111	Frequency for maximum input pulse	60 Hz	50 Hz	0 to 590 Hz	Set the frequency applicable to the time when the input pulse is maximum (gain).

*1 Gr.1 and Gr.2 are the parameter initial value groups. (Refer to page 46.)

*2 Function assigned to Pr.181 RM terminal function selection.

◆ Selection of pulse train input (Pr.291)

- Setting Pr.291 Pulse train input selection = "1" and Pr.384 Input pulse division scaling factor ≠ "0" changes the function of terminal RM to a pulse train input so that the inverter frequency can be set. In the initial setting, the RM signal is assigned to terminal RM. A maximum pulse train of 100k pulses/s can be input.
- Connection with an open collector output system pulse generator

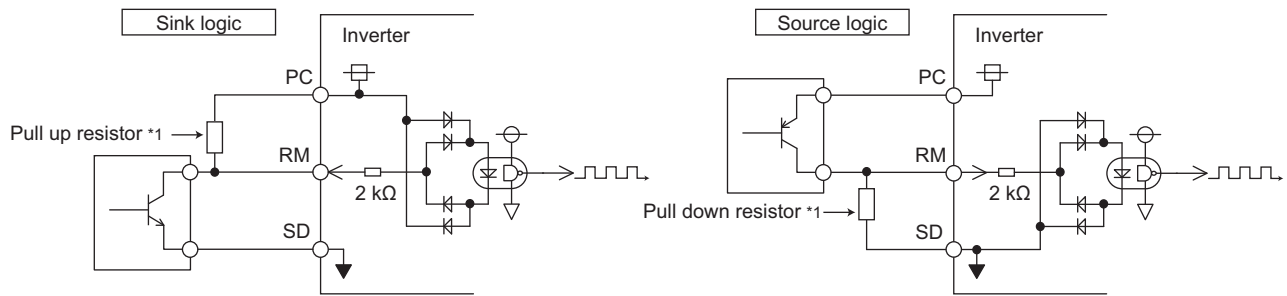

*1 When the wiring length is long with open collector outputs, the influence of stray capacitance causes the pulse to flatten out and prevents the input pulse from being recognized.

When the wiring length is long (10 m or longer of shielded twisted pair cable with a recommended cable gauge of 0.75 mm²), connect the open collector output signal to the power supply by an external pull-up resistor. The following table shows the reference resistance values for wiring length. The stray capacitance of the wiring changes considerably according to how the cable is laid, thus the above wiring lengths are not guaranteed values. When using a pull-up/down resistor, check the permissible power of the resistor and the permissible load current of the output transistor, and use within the permissible range.

Wiring length	Less than 10 m	10 to 50 m	50 to 100 m
Pull-up/down resistor	Not required	1 kΩ	470 Ω
Load current (reference)	10 mA	35 mA	65 mA

- Connection with a complementary output system pulse generator

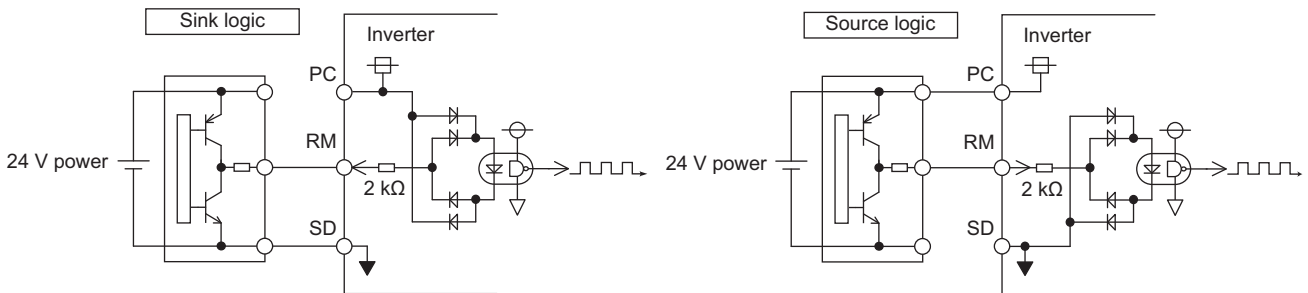

NOTE

- When pulse train input is selected, the function assigned to terminal RM by Pr.181 RM terminal function selection is invalid.

◆ Pulse train input specification

Item		Specification
Supported pulse method		Open collector output Complementary output (24 V power supply voltage)
HIGH input level		20 V or more (voltage between RM and SD)
LOW input level		5 V or less (voltage between RM and SD)
Maximum input pulse rate		100k pulses/s
Minimum input pulse width		2.5 μs
Input resistance/load current		2 kΩ (typ) / 10 mA (typ)
Maximum wiring length (reference value)	Open collector output method	10 m (0.75 mm ² /twisted pair)
	Complementary output method	100 m (output resistance 50 Ω) ^{*1}

*1 The wiring length of complementary output is dependent on the output wiring specification of the complementary output unit. The stray capacitance of the wiring changes considerably according to how the cable is laid, so the maximum wiring length is not a guaranteed value.

◆ Adjustment of pulse train and frequency (Pr.385, Pr.386)

- The frequency during zero input pulse and maximum input pulse can be set with **Pr.385 Frequency for zero input pulse** and **Pr.386 Frequency for maximum input pulse**, respectively.

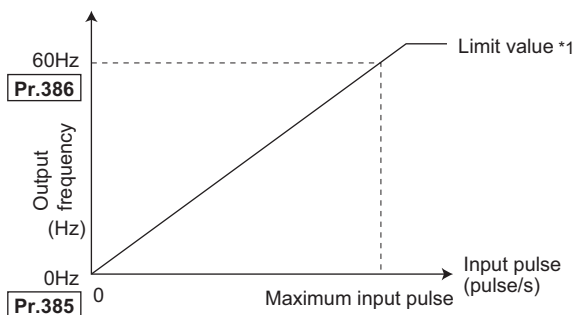

*1 Limit value = (Pr.386 - Pr.385) × 1.1 + Pr.385

◆ How to calculate the input pulse division scaling factor (Pr.384)

The maximum number of input pulses can be calculated by the following formula with **Pr.384 Input pulse division scaling factor**:

Maximum number of pulses (pulse/s) = **Pr.384** × 400 (maximum 100k pulses/s)

(number of detectable pulses = 11.11 pulses/s)

For example, to run the invert at 0 Hz when pulse train input is zero and at 30 Hz when pulse train is 4000 pulses/sec, set the inverter as follows:

Pr.384 = "10" (maximum number of input pulses 4000 pulses/s)

Pr.385 = 0 Hz, **Pr.386** = 30 Hz (pulse train limit value 33 Hz)

NOTE

- The priority of the frequency command given by the external signals is as follows: JOG operation (JOG/JOG2 signal) > multi-speed operation (RL/RM/RH/REX signal) > PID control (X14 signal) > terminal 4 analog input (AU signal) > pulse train input > terminal 2 analog input. When pulse train input is enabled (**Pr.291** = "1" and **Pr.384** ≠ "0"), terminal 2 analog input becomes disabled.

8.6 JOG operation

The frequency and acceleration/deceleration time for JOG operation can be set. JOG operation can be used for conveyor positioning, test operation, etc.

Pr.	Name	Initial value	Setting range	Description
15 D200	Jog frequency	5 Hz	0 to 590 Hz	Set the frequency for JOG operation.
16 F002	Jog acceleration/ deceleration time	0.5 s	0 to 3600 s	Set the motor acceleration/deceleration time during JOG operation. The acceleration/deceleration time is a period of time that the inverter takes to increase/decrease the output frequency to the frequency set in Pr.20 Acceleration/deceleration reference frequency ^{*1} . The acceleration/deceleration times cannot be set separately.

These parameters can be selected from among simple mode parameters when the LCD operation panel (FR-LU08) or the parameter unit (FR-PU07) is connected to the inverter.

*1 60 Hz is initially set in **Pr.20** in Group 1, and 50 Hz in Group 2. (Refer to [page 46](#).)

◆ JOG operation by inputting signals (JOG signal and JOG2 signal)

- Operation can be started and stopped by the start signals (STF and STR signals) when the Jog operation selection (JOG) signal or Jog operation selection 2 (JOG2) signal is ON. (For the operation method, refer to [page 41](#).)
- The JOG signal can be input only via a control circuit terminal. For the JOG signal, set "5" to any parameter from **Pr.178 to Pr.182 (Input terminal function selection)** to assign the function to a control circuit terminal.
- The JOG2 signal can be input via a control circuit terminal or via communication. For the JOG2 signal, set "30" to any parameter from **Pr.178 to Pr.182 and Pr.185 to Pr.189 (Input terminal function selection)** to assign the function to a control circuit terminal.
- Use the JOG acceleration/deceleration time function (**Pr.16**) to set the acceleration/deceleration time for JOG operation.

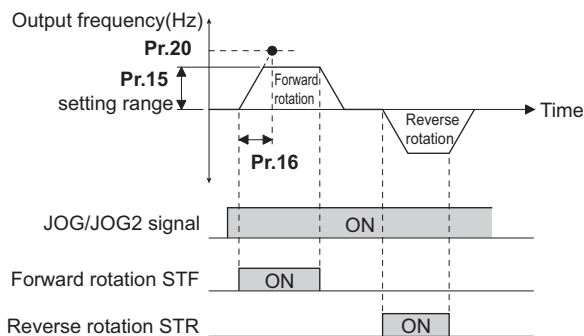

◆ JOG operation using the PU

- When the operation panel or parameter unit is in the JOG operation mode, the motor jogs only while a key for start command is pressed. (For the operation method, refer to [page 43](#).)

NOTE

- The priority of the frequency command given by the external signals is as follows: JOG operation (JOG/JOG2 signal) > multi-speed operation (RL/RM/RH/REX signal) > PID control (X14 signal) > terminal 4 analog input (AU signal) > pulse train input > terminal 2 analog input.
- The reference frequency during acceleration/deceleration depends on the **Pr.29 Acceleration/deceleration pattern selection** setting. (Refer to [page 133](#).)
- The **Pr.15** setting should be equal to or higher than the **Pr.13 Starting frequency** setting.
- Changing the terminal assignment using **Pr.178 to Pr.182 and Pr.185 to Pr.189 (Input terminal function selection)** may affect the other functions. Set parameters after confirming the function of each terminal.
- During JOG operation, the second acceleration/deceleration function using the RT signal is disabled. (Other second functions are enabled (refer to [page 257](#)).)
- When **Pr.79 Operation mode selection** = "4", JOG operation is started by one push of the RUN key on the operation panel or the FWD/REV key on the parameter unit, and stopped by the STOP/RESET key.
- This function is invalid when **Pr.79** = "3".

Parameters referred to

Pr.13 Starting frequency [page 139](#)

Pr.20 Acceleration/deceleration reference frequency [page 130](#)

Pr.29 Acceleration/deceleration pattern selection [page 133](#)

Pr.79 Operation mode selection [page 142](#)

Pr.178 to Pr.182 and Pr.185 to Pr.189 (Input terminal function selection) [page 252](#)

8.7 Operation by multi-speed setting

Use these parameters to change among pre-set operation speeds with the terminals. The speeds are pre-set with parameters. Any speed can be selected by simply turning ON/OFF the contact signals (RH, RM, RL, and REX signals).

Pr.	Name	Initial value ^{*1}		Setting range	Description
		Gr.1	Gr.2		
4 D301	Multi-speed setting (high speed)	60 Hz	50 Hz	0 to 590 Hz	Sets the frequency when RH is ON.
5 D302	Multi-speed setting (middle speed)	30 Hz		0 to 590 Hz	Sets the frequency when RM is ON.
6 D303	Multi-speed setting (low speed)	10 Hz		0 to 590 Hz	Sets the frequency when RL is ON.
24 D304	Multi-speed setting (speed 4)	9999		0 to 590 Hz, 9999	Frequency from 4th speed to 15th speed can be set according to the combination of the RH, RM, RL and REX signals. 9999: Not selected
25 D305	Multi-speed setting (speed 5)				
26 D306	Multi-speed setting (speed 6)				
27 D307	Multi-speed setting (speed 7)				
232 D308	Multi-speed setting (speed 8)				
233 D309	Multi-speed setting (speed 9)				
234 D310	Multi-speed setting (speed 10)				
235 D311	Multi-speed setting (speed 11)				
236 D312	Multi-speed setting (speed 12)				
237 D313	Multi-speed setting (speed 13)				
238 D314	Multi-speed setting (speed 14)				
239 D315	Multi-speed setting (speed 15)				

*1 Gr.1 and Gr.2 are the parameter initial value groups. (Refer to page 46.)

◆ Multi-speed setting (Pr.4 to Pr.6)

- The inverter operates at frequencies set in **Pr.4** when the RH signal is ON, **Pr.5** when the RM signal is ON, or **Pr.6** when the RL signal is ON.

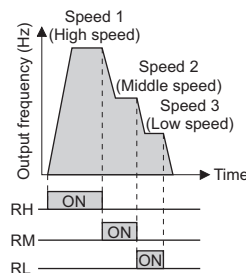
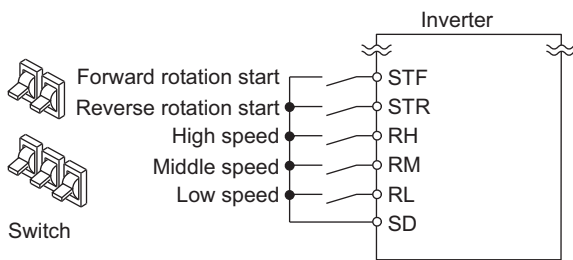

NOTE

- In the initial setting, if two or more speed switches (signals) are simultaneously turned ON, priority is given to the switch (signal) for the lower speed. For example, when both RH and RM signals turn ON, the RM signal (**Pr.5**) has the higher priority.
- The RH, RM and RL signals are assigned to the terminals RH, RM and RL, respectively, in the initial status. To assign each signal to a different terminal, set "0" (RL signal), "1" (RM signal), or "2" (RH signal) in any parameter from **Pr.178 to Pr.182** and **Pr.185 to Pr.189 (Input terminal function selection)**.

◆ Multi-speed setting for 4th speed or more (Pr.24 to Pr.27, Pr.232 to Pr.239)

- The frequency from 4th speed to 15th speed can be set according to the combination of the RH, RM, RL, and REX signals. Set the frequencies in **Pr.24 to Pr.27, Pr.232 to Pr.239**. (In the initial status, 4th to 15th speeds are invalid.)
- To input the REX signal, set "8" in any parameter from **Pr.178 to Pr.182 and Pr.185 to Pr.189 (Input terminal function selection)** to assign the function.

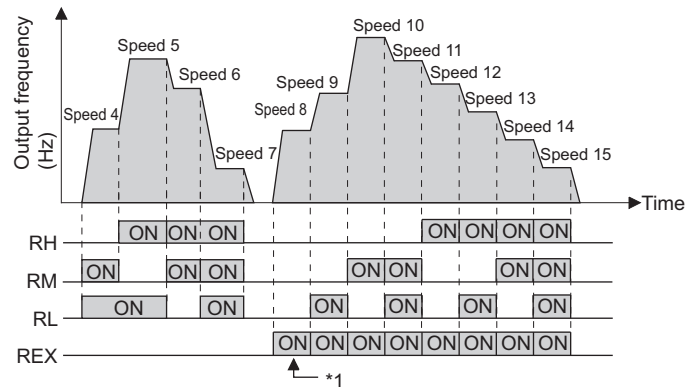
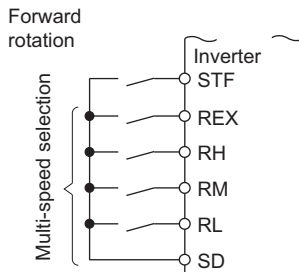

*1 When the RH, RM and RL signals are OFF and the REX signal is ON while "9999" is set to **Pr.232 Multi-speed setting (speed 8)**, the inverter operates at the frequency set in **Pr.6**.

NOTE

- The priority of the frequency command given by the external signals is as follows: JOG operation (JOG/JOG2 signal) > multi-speed operation (RL/RM/RH/REX signal) > PID control (X14 signal) > terminal 4 analog input (AU signal) > pulse train input > terminal 2 analog input. (For details on frequency commands given by analog input, refer to [page 248](#).)
- The input compensation of multi-speed setting is enabled when the inverter is in the External operation mode or PU/ External combined operation mode (**Pr.79** = "3 or 4").
- Multi-speed parameters can also be set during PU operation or External operation.
- The **Pr.24 to Pr.27 and Pr.232 to Pr.239** settings have no priority among them.
- When **Pr.59 Remote function selection** ≠ "0", the multi-speed setting is invalid since the RH, RM, and RL signals are for remote setting.
- Changing the terminal assignment using **Pr.178 to Pr.182 and Pr.185 to Pr.189 (Input terminal function selection)** may affect the other functions. Set parameters after confirming the function of each terminal.

Parameters referred to

Pr.15 Jog frequency [page 161](#)

Pr.59 Remote function selection [page 135](#)

Pr.79 Operation mode selection [page 142](#)

Pr.178 to Pr.182 and Pr.185 to Pr.189 (Input terminal function selection) [page 252](#)

9 (H) Protective Function Parameters

Purpose	Parameter to set			Refer to page
To protect the motor from overheating	Electronic thermal O/L relay	P.H000, P.H006, P.H010, P.H016, P.H020, P.H021	Pr.9, Pr.51, Pr.561, Pr.607, Pr.608, Pr.1016	166
To set the overheat protection characteristics for the motor	Free thermal O/L relay	P.H001 to P.H005, P.H011 to P.H015	Pr.600 to Pr.604, Pr.692 to Pr.696	166
To extend the life of the cooling fan	Cooling fan operation selection	P.H100	Pr.244	174
To detect an earth (ground) fault at start	Earth (ground) fault detection at start	P.H101	Pr.249	175
To detect a fault on the output side of the inverter	Inverter output fault detection enable/disable selection	P.H182	Pr.631	176
To initiate an inverter protective function	Fault initiation	P.H103	Pr.997	177
To disable the I/O phase loss protective function	I/O phase loss	P.H200, P.H201	Pr.251, Pr.872	178
To restart using the retry function when the protective function is activated	Retry operation	P.H300 to P.H303	Pr.65, Pr.67 to Pr.69	179
To operate without activating protective functions in case of emergency	Emergency drive	P.H320 to P.H324, P.A001, P.A004	Pr.136, Pr.139, Pr.514, Pr.515, Pr.523, Pr.524, Pr.1013	182
To check faulty area in the internal storage device	Internal storage device status indication	P.H325	Pr.890	190
To set the upper and lower limits of the output frequency	Maximum/minimum frequency	P.H400 to P.H402	Pr.1, Pr.2, Pr.18	191
To operate avoiding resonance points	Frequency jump	P.H420 to P.H425, P.H429	Pr.31 to Pr.36, Pr.552	193
To limit the output current so that the inverter protective function does not activate	Stall prevention	P.H500, P.H501, P.H600, P.H610, P.H611, P.H631, P.M430	Pr.22, Pr.23, Pr.48, Pr.66, Pr.154, Pr.156, Pr.157	195
To limit the torque during speed control	Torque limit	P.D030, P.D400 to P.D402, P.H500, P.H700, P.H710, P.H730, P.M430	Pr.22, Pr.157, Pr.804 to Pr.806, Pr.810, Pr.811, Pr.815	87
To monitor for load faults	Load characteristics fault detection	P.H520 to P.H527, P.H531 to P.H535	Pr.1480 to Pr.1492	200
To shut off output if the operation panel disconnects	Overspeed detection level	P.H800	Pr.374	205

9.1 Motor overheat protection (electronic thermal O/L relay)

Set the current of the electronic thermal relay function to protect the motor from overheating. Such settings provide the optimum protective characteristic considering the low cooling capability of the motor during low-speed operation.

Pr.	Name	Initial value	Setting range	Description
9 H000	Electronic thermal O/L relay	Inverter rated current ^{*1}	0 to 500 A	Set the rated motor current.
600 H001	First free thermal reduction frequency 1	9999	0 to 590 Hz 9999	The electronic thermal O/L relay operation level can be changed to match the motor temperature characteristics with the combination of these three points (Pr.600 , Pr.601), (Pr.602 , Pr.603), (Pr.604 , Pr.9). 9999: Free thermal O/L relay invalid
601 H002	First free thermal reduction ratio 1	100%	1% to 100% 9999	
602 H003	First free thermal reduction frequency 2	9999	0 to 590 Hz 9999	
603 H004	First free thermal reduction ratio 2	100%	1% to 100% 9999	
604 H005	First free thermal reduction frequency 3	9999	0 to 590 Hz 9999	
607 H006	Motor permissible load level	150%	110% to 250%	
51 H010	Second electronic thermal O/L relay	9999	0 to 500 A 9999	Enabled when the RT signal is ON. Set the rated motor current. Second electronic thermal O/L relay invalid
692 H011	Second free thermal reduction frequency 1	9999	0 to 590 Hz 9999	The electronic thermal O/L relay operation level can be changed to match the motor temperature characteristics with the combination of these three points (Pr.692 , Pr.693), (Pr.694 , Pr.695), (Pr.696 , Pr.51) when the RT signal is ON. 9999: Second free thermal O/L relay invalid
693 H012	Second free thermal reduction ratio 1	100%	1% to 100% 9999	
694 H013	Second free thermal reduction frequency 2	9999	0 to 590 Hz 9999	
695 H014	Second free thermal reduction ratio 2	100%	1% to 100% 9999	
696 H015	Second free thermal reduction frequency 3	9999	0 to 590 Hz 9999	
608 H016	Second motor permissible load level	9999	110% to 250% 9999	
561 H020	PTC thermistor protection level	9999	0.5 to 30 kΩ 9999	Set the PTC thermistor protection level (resistance). PTC thermistor protection disabled
1016 H021	PTC thermistor protection detection time	0 s	0 to 60 s	Set the time from when the resistance of the PTC thermistor reaches the protection level until the protective function is activated.

*1 The initial value for the FR-D820-0.75K-042 or lower, the FR-D840-0.75K-022 or lower, FR-D820S-0.75K-042 or lower, the FR-D810W-0.75K-042 or lower is set to the 85% of the inverter rated current.

◆ Electronic thermal O/L relay operation characteristic for induction motor (Pr.9)

- This function detects the overload (overheat) of the motor and shuts off the inverter output by stopping the operation of the transistor at the inverter output side.
- Set the rated current (A) of the motor in **Pr.9 Electronic thermal O/L relay**. (If the motor has both 50 Hz and 60 Hz ratings and **Pr.3 Base frequency** is set to 60 Hz, set to 1.1 times the 60 Hz rated motor current.)
- Set "0" in **Pr.9** to avoid activating the electronic thermal relay function; for example, when using an external thermal relay for the motor.
(Note that the output transistor protection of the inverter is activated. (E.THT))
- When using the Mitsubishi Electric constant-torque motor, set the constant-torque motor in **Pr.71 Applied motor** referring to [page 261](#). (This setting enables the 100% constant-torque characteristic in the low-speed range.)

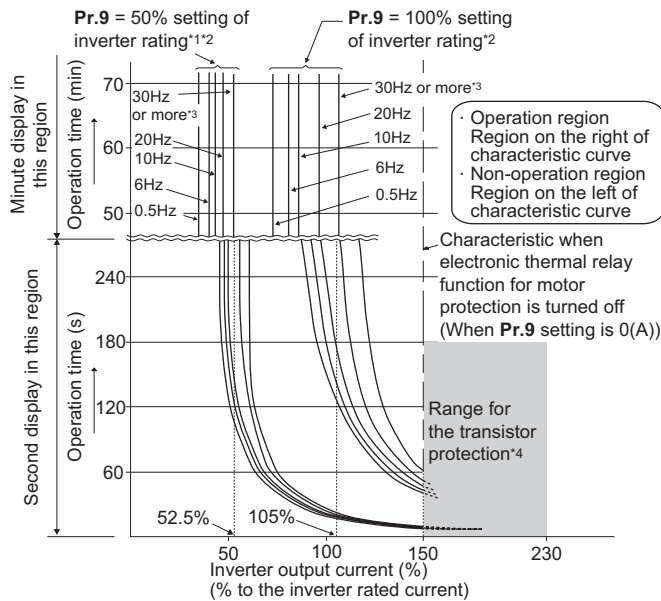

*1 When setting **Pr.9** to a value (current value) of 50% of the inverter rated current

*2 The % value denotes the percentage to the rated inverter current. It is not the percentage to the rated motor current.

*3 When the electronic thermal relay function dedicated to the Mitsubishi Electric constant-torque motor is set, this characteristic curve applies to operation. (For selection of the operation characteristic, refer to [page 261](#).)

*4 Transistor protection is activated depending on the temperature of the heat sink. The protection may be activated even with less than 150% depending on the operating conditions.

NOTE

- The internal accumulated heat value of the electronic thermal O/L relay is reset to the initial value by the inverter's power reset or reset signal input. Avoid unnecessary reset and power-OFF.
- Install an external thermal relay (OCR) between the inverter and motors to operate several motors, a multi-pole motor or a dedicated motor with one inverter. When setting an external thermal relay, note that the current indicated on the motor rating plate is affected by the line-to-line leakage current. The cooling effect of the motor drops during low-speed operation. Use a motor with built-in thermal protector. (For details of the line-to-line leakage current, refer to the Instruction Manual (Connection).)
- When the difference between the inverter and motor capacities is large and the set value is small, the protective characteristics of the electronic thermal relay function will be deteriorated. Use an external thermal relay in such cases.
- A dedicated motor cannot be protected by an electronic thermal O/L relay. Use an external thermal relay.
- The transistor protection thermal O/L relay is activated early when the **Pr.72 PWM frequency selection** setting is increased.

◆ Electronic thermal O/L relay when using PM motor (Pr.9)

- This function detects the overload (overheat) of the motor and shuts off the inverter output by stopping the operation of the transistor at the inverter output side.
- Set the rated current (A) of the motor in **Pr.9 Electronic thermal O/L relay**.
- Set "0" in **Pr.9** to avoid activating the electronic thermal relay function; for example, when using an external thermal relay for the motor.
(Note that the output transistor protection of the inverter is activated. (E.THT))
- When the EM-A motor is used, the rated motor current is automatically set by PM parameter initialization. (Refer to [page 77.](#))
- Operational characteristic of the electronic thermal relay function

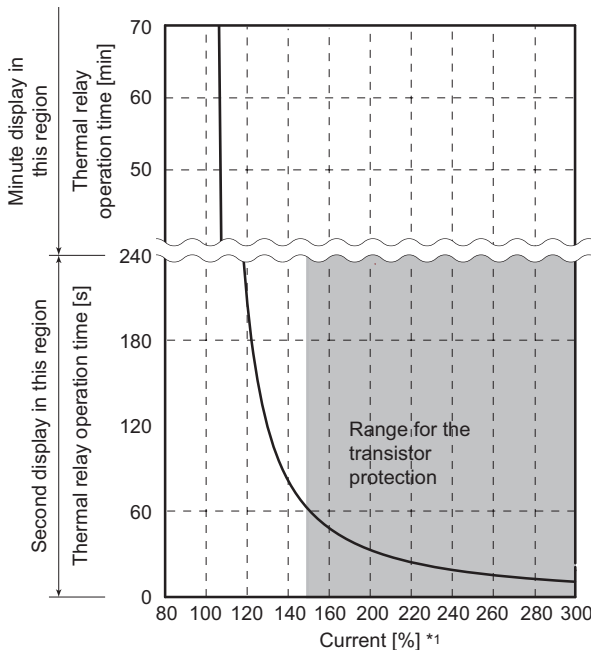

Protective function activated area: the area right of the characteristic curve

Normal operation area: the area left of the characteristic curve

*1 The % value denotes the percentage to the rated motor current.

NOTE

- The internal accumulated heat value of the electronic thermal O/L relay is reset to the initial value by the inverter's power reset or reset signal input. Avoid unnecessary reset and power-OFF.
- When using a PM motor, set the free thermal parameters (**Pr.600 to Pr.604**) in accordance with the motor characteristic.
- The transistor protection thermal O/L relay is activated early when the **Pr.72 PWM frequency selection** setting is increased.

◆ Setting two types of electronic thermal O/L relays (Pr.51)

- These settings are used when rotating two motors with different rated current separately by a single inverter under V/F control. (When rotating two motors together, use an external thermal relay.) Set the rated motor current for the second motor in **Pr.51 Second electronic thermal O/L relay**.

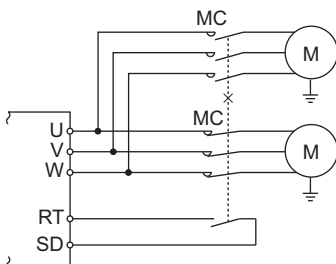

- To set two types of electronic thermal O/L relays for one motor under Advanced magnetic flux vector control, use **Pr.51 Second electronic thermal O/L relay**.
- While the RT signal is ON, the setting values of **Pr.51** is referred to provide thermal protection.

Pr.450 Second applied motor	Pr.9 Electronic thermal O/L relay	Pr.51 Second electronic thermal O/L relay	RT signal OFF		RT signal ON	
			First electronic thermal O/L relay	Second electronic thermal O/L relay	First electronic thermal O/L relay	Second electronic thermal O/L relay
9999	0	9999	x	x	x	x
		0	x	x	x	x
		0.01 to 500 (0.1 to 3600)	x	Δ	x	○
9999	Other than 0	9999	○	x	○	x
		0	○	x	Δ	x
		0.01 to 500 (0.1 to 3600)	○	Δ	Δ	○
Other than 9999	0	9999	x	x	x	x
		0	x	x	x	x
		0.01 to 500 (0.1 to 3600)	x	Δ	x	○
Other than 9999	Other than 0	9999	○	Δ	Δ	○
		0	○	x	Δ	x
		0.01 to 500 (0.1 to 3600)	○	Δ	Δ	○

○: Values are accumulated by using the output current.

Δ: Values are accumulated by assuming the output current is 0 A (cooling processing).

x: Electronic thermal O/L relay does not operate.

NOTE

- The RT signal is the Second function selection signal. The RT signal also enables other second functions. (Refer to [page 257](#).)
- To input the RT signal, set "3" in any parameter from **Pr.178 to Pr.182** and **Pr.185 to Pr.189 (Input terminal function selection)** to assign the function.
- Changing the terminal assignment using **Pr.178 to Pr.182** and **Pr.185 to Pr.189 (Input terminal function selection)** may affect the other functions. Set parameters after confirming the function of each terminal.
- The second electronic thermal O/L relay is disabled under PM sensorless vector control. (Operation when **Pr.450** = "9999" and **Pr.51** = "9999" is performed.)

9

◆ Motor permissible load level (Pr.607, Pr.608)

The electronic thermal O/L relay operation characteristic can be changed by setting the permissible load level according to the motor characteristics.

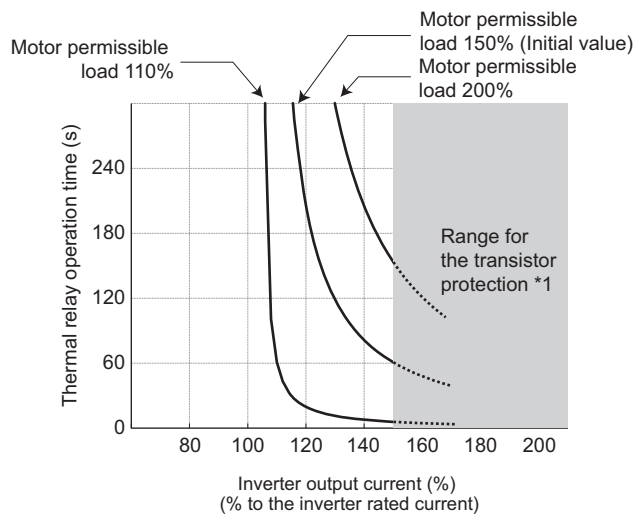

Example of motor permissible load setting
(when Pr.9="100% of the inverter rating")

*1 Depending on the settings of **Pr.607** and **Pr.608**, this thermal protection may not be provided as set, as an inverter overload trip (electronic thermal relay function) (E.THT) may be activated before the thermal protection.

◆ Electronic thermal O/L relay pre-alarm (TH) and warning signal (THP signal)

- If the accumulated electronic thermal value reaches 85% of the **Pr.9** or **Pr.51** setting, electronic thermal O/L relay function pre-alarm (TH) is displayed and the Electronic thermal O/L relay pre-alarm (THP) signal is output. If the value reaches 100% of the **Pr.9** setting, the motor thermal protection (E.THM/E.THT) is activated to shut off the inverter output. The inverter output is not shut off with the TH display.
- For the THP signal output, set "8" (positive logic) or "108" (negative logic) in any parameter from **Pr.190 to Pr.196 (Output terminal function selection)** to assign the function.

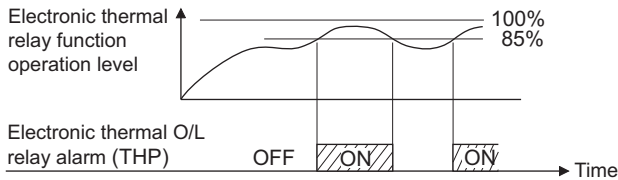

NOTE

- Changing the terminal assignment using **Pr.190 to Pr.196 (Output terminal function selection)** may affect the other functions. Set parameters after confirming the function of each terminal.

◆ External thermal relay input (OH signal, E.OHT)

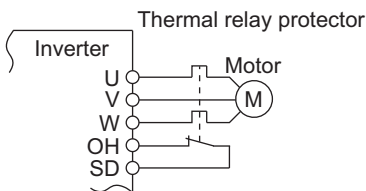

External thermal relay input connection diagram

- The External thermal relay input (OH) signal is used when using the external thermal relay or the thermal protector built into the motor to protect the motor from overheating.
- When the thermal relay is activated, the inverter output is shut off by the external thermal relay (E.OHT).
- To input the OH signal, set "7" in any parameter from **Pr.178 to Pr.182 and Pr.185 to Pr.189 (Input terminal function selection)** to assign the function.

NOTE

- Changing the terminal assignment using **Pr.178 to Pr.182 and Pr.185 to Pr.189 (Input terminal function selection)** may affect the other functions. Set parameters after confirming the function of each terminal.

◆ PTC thermistor input (Pr.561, Pr.1016, E.PTC)

This function is used to protect the motor from overheating by inputting outputs from the motor's built-in PTC thermistor to the inverter. It is recommended that a PTC thermistor whose resistance increases most rapidly around the rated activating temperature ($T_N \pm DT$) is used.

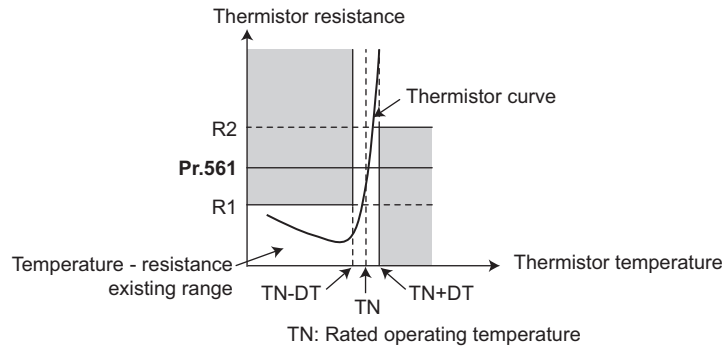
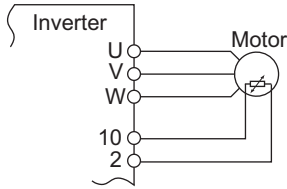

PTC thermistor input connection diagram

Example of PTC thermistor characteristics

- Outputs from the motor's built-in PTC thermistor can be input to terminals 2 and 10. If the input from the PTC thermistor reaches the resistor value set in **Pr.561 PTC thermistor protection level**, E.PTC (PTC thermistor operation) shuts off the inverter output.
- Confirm the characteristic of the PTC thermistor to be used, and set the resistance for **Pr.561** around the center of the R1 and R2 values shown on the figure above so that it does not deviate from the protective function activating temperature T_N . If the **Pr.561** setting becomes too close to R1 or R2, the protective function activating temperature may be too hot (protection is delayed), or too cold (too much protection).
- When the PTC thermistor protection is enabled (**Pr.561** \neq "9999"), the resistance value for the PTC thermistor can be displayed on the operation panel or via communication. (Refer to [page 208](#).)
- When the PTC thermistor protection level setting is used, use **Pr.1016 PTC thermistor protection detection time** to set the time from when the resistance of the PTC thermistor reaches the protection level until the protective function (E.PTC) is activated.
- If the resistance of the PTC thermistor falls below the protection level within the protection detection time, the elapsed time count is cleared.

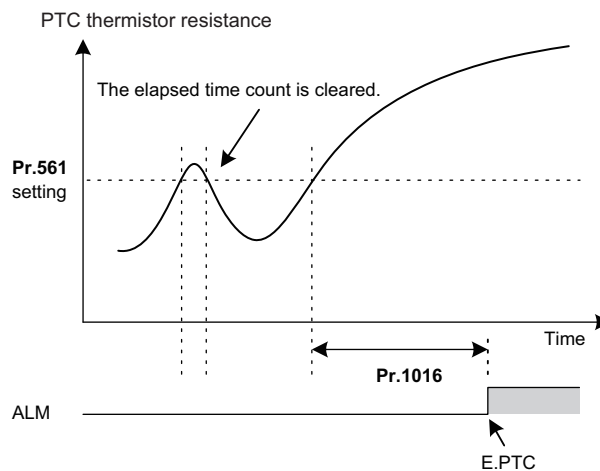

NOTE

- When using terminal 2 for PTC thermistor input (**Pr.561** ≠ "9999"), terminal 2 does not operate as an analog frequency command terminal. When a function for the PID control or dancer control is assigned to terminal 2, the function is disabled. Use **Pr.133 PID action set point** to set the set point for the PID control. When the PID control and dancer control are disabled (**Pr.128 PID action selection** = "0"), terminal 4 operates as follows.
Pr.79 = "4" or External operation mode is selected: Terminal 4 input is valid regardless of ON/OFF state of the AU signal.
Pr.79 = "3": Frequency command given via terminal 4 is valid only when the AU signal is ON.
- To input power to the PTC thermistor power supply, always use the terminal 10 and do not use any other terminals or an external power supply. Otherwise, E.PTC (PTC thermistor protection) does not operate properly.
- When E.PTC is activated, the alarm display, "External protection (AU terminal)", may appear on the parameter unit (FR-PU07), but it is not a fault.

◆ Overheat protection to match the characteristic of the motor (Pr.600 to Pr.604, Pr.692 to Pr.696)

- The activation level of the electronic thermal O/L relay can be varied to match the motor temperature characteristic.
- The electronic thermal O/L relay operation level can be set with the combination of three points (**Pr.600, Pr.601**), (**Pr.602, Pr.603**), (**Pr.604, Pr.9**). Two or more points are required for setting.
- The electronic thermal O/L relay operation level can be set with the combination of three points (**Pr.692, Pr.693**), (**Pr.694, Pr.695**), (**Pr.696, Pr.51**) when the RT signal is ON.

Continuous operation characteristic

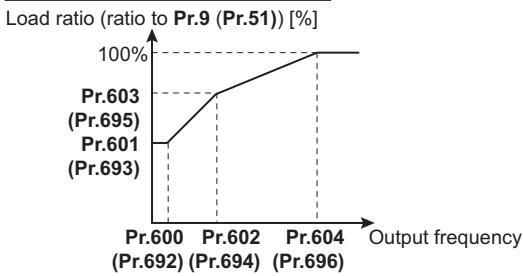

Setting example 1

Pr.9=100% of the rated motor current
Pr.600=6Hz
Pr.601=50%
Pr.602=30Hz
Pr.603=70%
Pr.604=60Hz

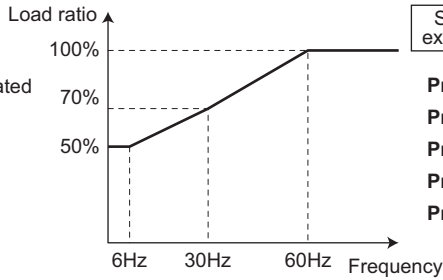

Setting example 2

Pr.600=120Hz
Pr.601=60%
Pr.602=3Hz
Pr.603=50%
Pr.604=60Hz

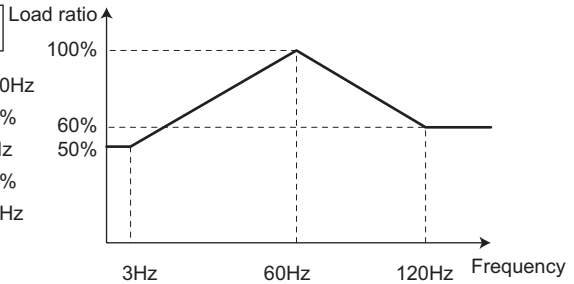

- When setting **Pr.600, Pr.602, Pr.604 (Pr.692, Pr.694, Pr.696)** to the same frequency, the following graph's upper level is applied.

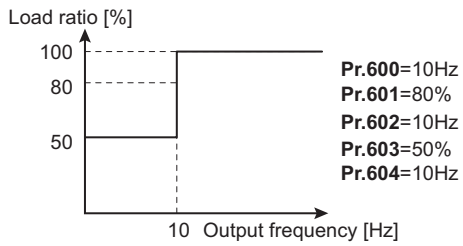

NOTE

- Make sure to set the parameters according to the temperature characteristic of the motor used.

Parameters referred to

Pr.71 Applied motor [page 261](#)

Pr.72 PWM frequency selection [page 120](#)

Pr.178 to Pr.182 and Pr.185 to Pr.189 (Input terminal function selection) [page 252](#)

Pr.190 to Pr.196 (Output terminal function selection) [page 226](#)

9.2 Cooling fan operation selection

The cooling fan built into the inverter can be controlled.

Pr.	Name	Initial value	Setting range	Description
244 H100	Cooling fan operation selection	1	0	Cooling fan ON/OFF control disabled. (The cooling fan is always ON at power ON.) A cooling fan operates at power ON.
			1	Cooling fan ON/OFF control enabled. The fan is always ON while the inverter is running. During a stop, the inverter status is monitored and the fan switches ON/OFF according to the temperature.

◆ Cooling fan always ON (Pr.244 = "0")

- When **Pr.244** = "0", the cooling fan operates at power ON. If the fan stops at this time, fan operation is regarded as faulty, Fan alarm (FN) is displayed on the operation panel, and the FAN fault output (FAN) and Alarm (LF) signals are output.
- For the FAN signal output, set "25" (positive logic) or "125" (negative logic) in any parameter from **Pr.190 to Pr.196 (Output terminal function selection)**. For the LF signal, set "98" (positive logic) or "198" (negative logic).

◆ Cooling fan operation control (Pr.244 = "1 (initial value)")

- The cooling fan operation is controlled when **Pr.244** = "1". When the inverter is running, the cooling fan operates constantly. When the inverter is stopped, the cooling fan operates depending on the temperature of the inverter heat sink. If the fan stops although it meets the conditions for running, fan operation is regarded as faulty, "FN" is displayed on the operation panel, and the FAN signal and the LF signal are output.

◆ Cooling fan operation command (Y206) signal

- The cooling fan operation command (Y206) signal can be output when the inverter cooling fan meets the conditions for running. The function can be used when the fan installed on the enclosure is synchronized with the inverter cooling fan.
- The Y206 signal indicates the operating command condition of the inverter cooling fan depending on the power supply ON/OFF or the **Pr.244** settings. The signal does not indicate the actual operation of the cooling fan. (The signal is output even if the cooling fan is stopped due to a fault.)
- To use the Y206 signal, set "206" (positive logic) or "306" (negative logic) in any parameter from **Pr.190 to Pr.196 (Output terminal function selection)** to assign the function to an output terminal.

NOTE

- The cooling fan is installed on the FR-D820-2.2K-100 or higher, the FR-D840-2.2K-050 or higher, and the FR-D820S-2.2K-100.
- If the safety stop function is activated to shut off the inverter output in the FR-D820-2.2K-100, FR-D820-3.7K-165, or FR-D820S-2.2K-100, the cooling fan operates at the next power-ON.
- For the FR-D820-3.7K-165 to FR-D820-7.5K-318, FR-D840-5.5K-120, and FR-D840-7.5K-163, the cooling fan speed automatically varies according to the temperature of the heat sink. As a result, the operating noise of the cooling fan may vary depending on the surrounding air temperature of the inverter or the motor load.
- Changing the terminal assignment using **Pr.190 to Pr.196 (Output terminal function selection)** may affect the other functions. Set parameters after confirming the function of each terminal.

Parameters referred to

Pr.190 to Pr.196 (Output terminal function selection)  [page 226](#)

9.3 Earth (ground) fault detection at start

Select whether to make earth (ground) fault detection at start. When enabled, earth (ground) fault detection is performed immediately after a start signal input to the inverter.

Pr.	Name	Initial value ^{*1}		Setting range	Description
		Gr.1	Gr.2		
249 H101	Earth (ground) fault detection at start	0	1	0	Earth (ground) fault detection at start disabled
				1	Earth (ground) fault detection at start enabled

*1 Gr.1 and Gr.2 are the parameter initial value groups. (Refer to [page 46](#).)

- If a ground fault is detected at start while **Pr.249** = "1", the output-side earth (ground) fault overcurrent (E.GF) is displayed and the outputs are shut off.
- When the **Pr.72 PWM frequency selection** setting is high, enable the ground fault detection at start.

NOTE

- Because the detection is performed at start, output is delayed for approx. 20 ms every start.
- Use **Pr.249** to enable/disable ground fault detection at operation start.

9.4 Inverter output fault detection enable/disable selection

Faults occurred on the output side (load side) of the inverter (inverter output fault (E.10)) can be detected during operation.

Pr.	Name	Initial value	Setting range	Description
631	Inverter output fault detection enable/disable selection	0	0	Output fault detection disabled
H182			1	Output fault detection enabled

9.5 Initiating a protective function

A fault (protective function) is initiated by setting the parameter.

This function can be used to check how the system operates at activation of a protective function.

Pr.	Name	Initial value	Setting range	Description
997 H103	Fault initiation	9999	16 to 253	The setting range is the same with the one for fault data codes of the inverter (which can be read through communication). Written data is not stored in EEPROM.
			9999	The read value is always "9999". The protective function is not activated with this setting.

- To initiate a fault (protective function), set the assigned number of the protective function to be initiated in **Pr.997**.
- The value set in **Pr.997** is not stored in EEPROM.
- When the protective function is activated, the inverter output is shut off and the inverter displays the fault indication and outputs a Fault (ALM) signal.
- The latest fault in the fault history is displayed while the fault initiation function is in operation. After a reset, the fault history goes back to the previous status. (The protective function generated by the fault is not saved in the fault history.)
- Perform inverter reset to cancel the protective function.
- For the selectable parameter by **Pr.997** and the corresponding protective functions, refer to the Instruction Manual (Maintenance).

NOTE

- If a protective function is already operating, no fault can be activated by **Pr.997**.
- The retry function is disabled when a protective function has been initiated by the fault initiation function.
- If a fault occurs after a protective function has been activated, the protective function indication does not change. The fault is not saved in the fault history either.

9.6 I/O phase loss protection selection

The output phase loss protection function, which stops the inverter output if one of the three phases (U, V, W) on the inverter's output side (load side) is lost, can be disabled.

The input phase loss protective function on the inverter input side (R/L1, S/L2, T/L3) can be disabled.

Pr.	Name	Initial value	Setting range	Description
251 H200	Output phase loss protection selection	1	0	Output phase loss protection disabled
			1	Output phase loss protection enabled
872 H201 ^{*1}	Input phase loss protection selection	1	0	Input phase loss protection disabled
			1	Input phase loss protection enabled

*1 Available for the three-phase power input model only.

◆ Output phase loss protection selection (Pr.251)

- When Pr.251 = "0", output phase loss protection (E.LF) becomes invalid.

◆ Input phase loss protection selection (Pr.872)

- When Pr.872 = "1", Input phase loss (E.ILF) protection is activated if one of three phases is continuously lost for one second.

NOTE

- When several motors are connected, output phase loss cannot be detected even if the wiring to one motor loses phase.
- If an input phase loss continues for a long time, the lives of converter section and capacitor of the inverter become shorter.
- If the load is light or during a stop, lost phase cannot be detected because detection is performed based on the fluctuation of bus voltage. Large unbalanced phase-to-phase voltage of the three-phase power supply may also cause input phase loss protection (E.ILF).
- Phase loss cannot be detected during regeneration load operation.

◀ Parameters referred to ▶

Pr.261 Power failure stop selection  [page 318](#)

9.7 Retry function

This function allows the inverter to reset itself and restart at activation of the protective function (fault indication). The retry generating protective functions can also be selected.

When the automatic restart after instantaneous power failure function is selected (**Pr.57 Restart coasting time** ≠ "9999"), the restart operation is also performed after a retry operation as well as after an instantaneous power failure. (For restart operation, refer to [page 307](#) and [page 312](#) for selection.)

Pr.	Name	Initial value	Setting range	Description
65 H300	Retry selection	0	0 to 5	Faults which trigger the retry operation can be selected.
67 H301	Number of retries at fault occurrence	0	0	The retry function disabled.
			1 to 10	Set the number of retries at a fault occurrence. A fault output is not provided during the retry operation.
			101 to 110	Set the number of retries at a fault occurrence. (The setting value minus 100 is the number of retries.) A fault output is provided during the retry operation.
68 H302	Retry waiting time	1 s	0.1 to 600 s	Set the time delay from when an inverter fault occurs until the retry operation starts.
69 H303	Retry count display erase	0	0	Clears the number of restarts succeeded by retries.

◆ Setting the retry function (Pr.67, Pr.68)

- When the inverter protective function is operating (fault indication), the retry function automatically cancels (resets) the protective function after the time set in **Pr.68**. The retry function then restarts the operation from the starting frequency.
- The retry function is enabled when the **Pr.67** setting is other than "0". Set the number of retries at activation of the protective function in **Pr.67**.

Pr.67 setting	Fault output during retry operation	Retry count
0	—	No retry function
1 to 10	Not available	1 to 10 times
101 to 110	Available	1 to 10 times

- When retries fail consecutively the number of times set in **Pr.67**, a retry count excess (E.RET) occurs, resulting in an inverter retries. (Refer to the Retry failure example.)
- Use **Pr.68** to set the waiting time from a protective function activation to a retry in the range of 0.1 to 600 seconds.
- During retry operation, the During retry (Y64) signal is ON. For the Y64 signal, set "64" (positive logic) or "164" (negative logic) in any parameter from **Pr.190 to Pr.196 (Output terminal function selection)** to assign the function.

◆ Retry count check (Pr.69)

- Reading the **Pr.69** value provides the cumulative number of successful restart times made by retries. The cumulative count in **Pr.69** increases by 1 when a retry is successful. Retry is regarded as successful when normal operation continues without a fault for the **Pr.68** setting multiplied by four or longer (3.3 seconds at the shortest). (When retry is successful, the cumulative number of retry failures is cleared.)
- Writing "0" in **Pr.69** clears the cumulative count.

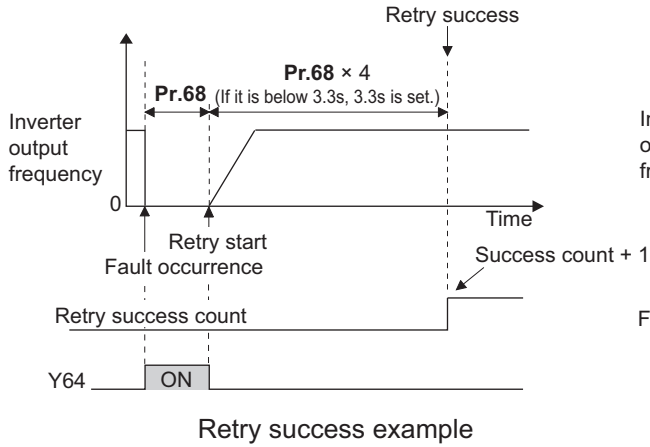

Retry success example

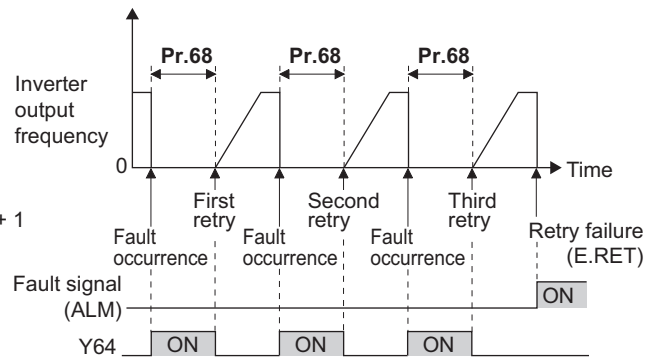

Retry failure example

◆ Selecting retry generating faults (Pr.65)

- Using **Pr.65**, the fault that causes a retry is selectable. The faults not described in the following table do not enable the retry function. (For details on faults, refer to the Instruction Manual (Maintenance).) ● indicates the faults selected for retry.

Retry-triggering fault	Pr.65 setting					
	0	1	2	3	4	5
E.OC1	●	●		●	●	●
E.OC2	●	●		●	●	
E.OC3	●	●		●	●	●
E.OV1	●		●	●	●	
E.OV2	●		●	●	●	
E.OV3	●		●	●	●	
E.THM	●					
E.THT	●					
E.UVT	●				●	
E.GF	●				●	
E.OHT	●					
E.OLT	●				●	

Retry-triggering fault	Pr.65 setting					
	0	1	2	3	4	5
E.PE	●				●	
E.OS	●				●	
E.PTC	●					
E.CDO	●				●	
E.USB	●				●	
E.ILF	●				●	
E.PID	●				●	
E.SOT	●	●		●	●	●
E.LUP	●				●	
E.LDN	●				●	
E.10	●				●	

NOTE

- Use the retry function only when the operation can be resumed after resetting a protective function activation. Making a retry against the protective function, which is activated by an unknown condition, will lead the inverter and motor to be faulty. Identify and remove the cause of the protective function activation before restarting the operation.
- If the retry function operates during PU operations, the operating conditions (forward/reverse rotation) are stored; and operations resume after retry reset.
- Only the fault details for the first fault that occurred during retry are stored in the fault history.
- The reset by the retry function does not clear the accumulated data of the electronic thermal O/L relay, regenerative brake duty, etc. (This is different from power supply reset or reset by RES signal.)
- When the parameter storage device fault (control circuit board) (E.PE) is occurring and reading of the retry-function-related parameters is not possible, retry cannot be operated.
- Changing the terminal assignment using **Pr.190 to Pr.196 (Output terminal function selection)** may affect the other functions. Set parameters after confirming the function of each terminal.

CAUTION

- When the retry function is set enabled, stay away from the motor and machine in the case of an output shutoff. The motor and machine will start suddenly (after the reset time has elapsed) after the shutoff. When the retry function has been selected, apply the CAUTION sticker(s), which are found in the Instruction Manual (Connection), to easily visible places.

Parameters referred to

Pr.57 Restart coasting time  [page 307](#), [page 312](#)

Pr.190 to Pr.196 (Output terminal function selection)  [page 226](#)

9.8 Emergency drive

The inverter can continue driving the motor in case of emergency such as a fire, since protective functions are not activated even if the inverter detects a fault. Using this function may damage the motor or inverter because driving the motor is given the highest priority. Use this function for emergency operation only. The operation can be switched to the commercial power supply operation at the occurrence of a fault which may cause damage of the inverter.

Pr.	Name	Initial value ^{*1}		Setting range	Description
		Gr.1	Gr.2		
523 H320	Emergency drive mode selection	9999		100, 111, 112, 121, 122, 200, 211, 212, 221, 222, 300, 311, 312, 321, 322, 400, 411, 412, 421, 422	Select the operation mode of the emergency drive.
				9999	Emergency drive disabled.
524 H321 ^{*2}	Emergency drive running speed	9999		0 to 590 Hz ^{*3}	Set the running frequency in the fixed frequency mode of the emergency drive (when the fixed frequency mode is selected in Pr.523)
				0% to 100% ^{*3}	Set the PID set point in the PID control mode of the emergency drive (when the PID control mode is selected in Pr.523)
				9999 ^{*3}	Emergency drive disabled.
515 H322	Emergency drive dedicated retry count	1		1 to 200	Set the retry count during emergency drive operation.
				9999 ^{*3}	Without retry count excess (no restriction on the number of retries).
1013 H323	Running speed after recovery from emergency drive undervoltage	60 Hz	50 Hz	0 to 590 Hz	Set the frequency for operation after a reset when undervoltage occurs during emergency drive operation.
514 H324	Emergency drive dedicated retry waiting time	9999		0.1 to 600 s	Set the retry waiting time during emergency drive operation.
				9999	The Pr.68 setting is applied to the operation.
136 A001	MC switchover interlock time	1 s		0 to 100 s	Set the operation interlock time for MC2 and MC3.
139 A004	Automatic switchover frequency from inverter to bypass operation	9999		0 to 60 Hz	Set the frequency at which the inverter-driven operation is switched over to the commercial power supply operation when the condition for the electronic bypass is established during emergency drive operation.
				9999	Electronic bypass during emergency drive is disabled.

*1 Gr.1 and Gr.2 are the parameter initial value groups. (Refer to [page 46](#).)

*2 Set **Pr.523** before setting **Pr.524**.

*3 When **Pr.523** = "100, 200, 300, or 400", the emergency drive is activated regardless of the **Pr.524** setting.

◆ Connection diagram

- The following diagram shows a connection example for emergency drive operation (in the commercial mode).

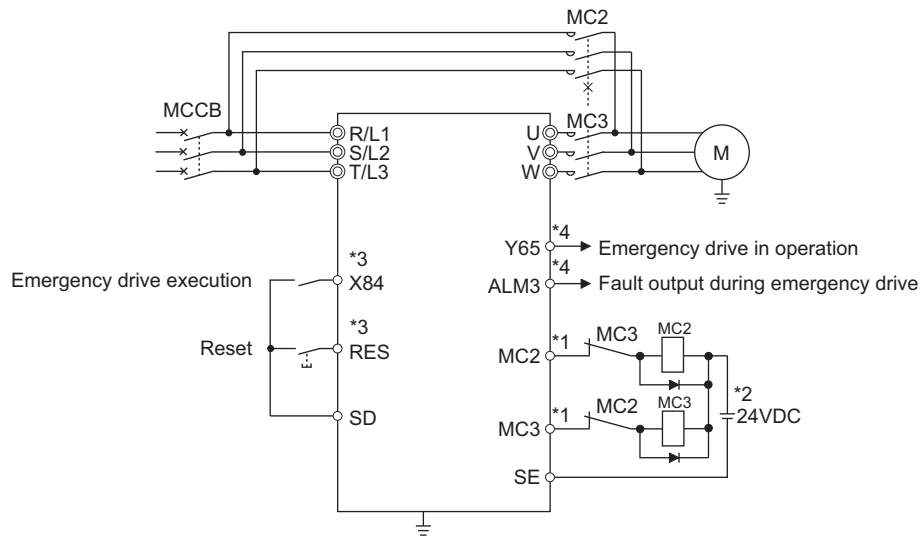

- *1 Be careful of the capacity of the sequence output terminals.
The applied terminals differ by the settings of **Pr.190 to Pr.192 (Output terminal function selection)**.

Output terminal capacity	Output terminal permissible load
Open collector output of inverter (RUN, R+/FU ^{*5})	24 VDC 0.1 A
Inverter relay output (A-C, B-C)	240 VAC 2 A 30 VDC 1 A

- *2 When connecting a DC power supply, insert a protective diode.
When connecting an AC power supply, use relay output terminals of the inverter.
- *3 The applied terminals differ by the settings of **Pr.180 to Pr.182 (Input terminal function selection)**.
- *4 The applied terminals differ by the settings of **Pr.190 to Pr.196 (Output terminal function selection)**.
- *5 When the R+/FU switch (SW5) is set to the upper position (FU) (initial status), the assigned function is enabled. Assignment is not available when the RS-485 terminal is used for RS-485 communication. For details, refer to the Instruction Manual (Connection) and the Instruction Manual (Communication).

NOTE

- Be sure to provide a mechanical interlock for MC2 and MC3.
- The emergency drive function is disabled when the Inverter run enable (X10) signal is assigned.

◆ Emergency drive execution sequence

Point

- When the X84 signal is ON for 3 seconds, the emergency drive is activated.
- The Y65 signal is ON during emergency drive operation.
- "ED" is displayed on the operation panel during emergency drive operation.
- The ALM3 signal is ON when a fault occurs during emergency drive operation.
- For protective functions (faults) valid during emergency drive operation, refer to [page 187](#).

- The following diagram shows the operation of the emergency drive function (in the retry / output shutoff mode or in the fixed frequency mode (**Pr.523** = "211")).

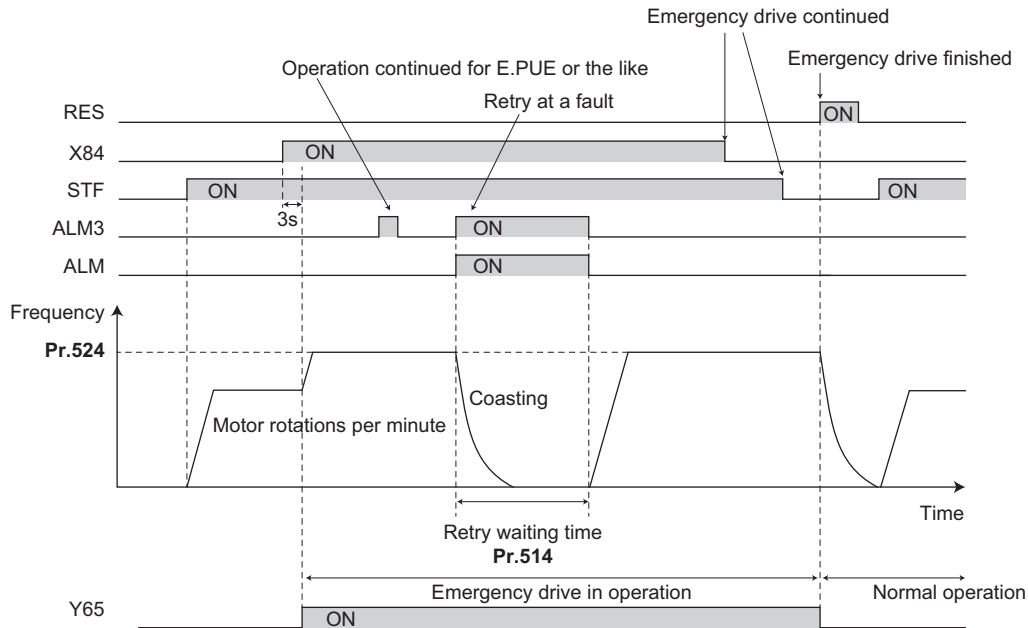

- The following diagram shows the operation of switching over to the commercial power supply operation during emergency drive operation at a fault occurrence (in the commercial mode or in the fixed frequency mode (**Pr.523** = "411")).

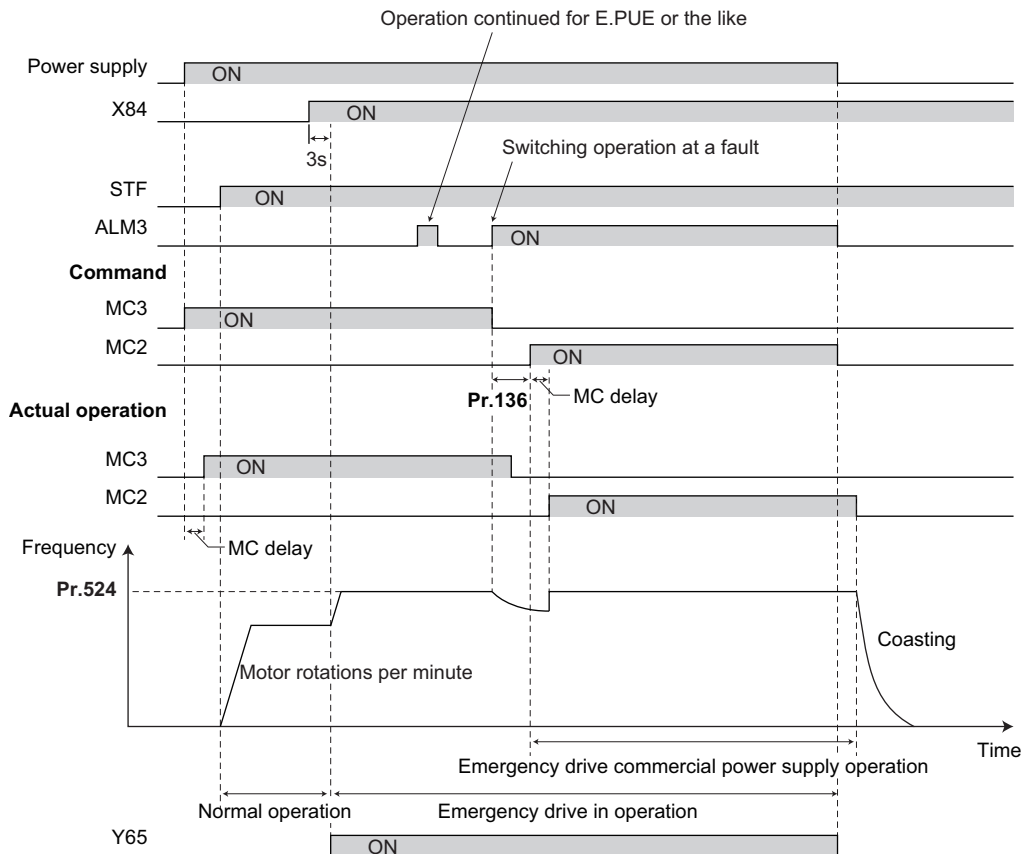

◆ Emergency drive operation selection (Pr.523, Pr.524)

- Use **Pr.523 Emergency drive mode selection** to select the emergency drive operation.
Set a value in the hundreds place to select the operation when a valid protective function is activated (fault) during emergency drive operation. Set values in the ones and tens places to select the operation method.
- For protective functions (faults) valid during emergency drive operation, refer to [page 187](#).

Pr.523 setting	Emergency drive operation mode		Description
1□□	Output shutoff mode		Selecting operation when a fault occurs during emergency drive operation
2□□	Retry / output shutoff mode		
3□□ ^{*1}	Retry / commercial mode		
4□□ ^{*1}	Commercial mode		
□00	Normal operation		Selecting the operation method during emergency drive operation
□11	Fixed frequency mode	Forward rotation	
□12		Reverse rotation	
□21	PID control mode	Forward rotation	
□22		Reverse rotation	
9999	Emergency drive disabled.		

*1 Under PM sensorless vector control, the operation is not switched over to the commercial power supply operation and the output is shut off.

◆ Retry operation during emergency drive operation (Pr.515, Pr.514)

- Set the retry operation during emergency drive operation. Use **Pr.515 Emergency drive dedicated retry count** to set the retry count, and use **Pr.514 Emergency drive dedicated retry waiting time** to set the retry waiting time.
- The ALM signal output conditions depend on the **Pr.67 Number of retries at fault occurrence** setting. The signal is not output when **Pr.67 = "0"**. (Refer to [page 179](#).)
- For the protective functions (faults) for which retry is permitted during emergency drive operation, refer to [page 187](#).

NOTE

- **Pr.65 Retry selection** is disabled during emergency drive operation.

◆ Electronic bypass during emergency drive (Pr.136, Pr.139)

- For selecting the commercial mode (**Pr.523 = "3□□, 4□□"**), setting is required as follows.
Set **Pr.136 MC switchover interlock time** and **Pr.139 Automatic switchover frequency from inverter to bypass operation** and assign the MC2 and MC3 signals to output terminals.
Select V/F control or Advanced magnetic flux vector control. (Under PM sensorless vector control, the operation is not switched over to the commercial power supply operation and the output is shut off.)
- During emergency drive operation, the operation is switched over to the commercial power supply operation when any of the following conditions is satisfied.
A fault for which retry is not permitted occurs while **Pr.523 = "3□□"**.
A fault occurs while **Pr.523 = "4□□"**.
Undervoltage occurs.
- While the motor is driven by the inverter during emergency drive operation, if a condition for electronic bypass is satisfied, the output frequency is accelerated/decelerated to the **Pr.139** setting. When the frequency reaches the set frequency, the operation is switched over to the commercial power supply operation. (The operation is immediately switched over to the commercial power supply operation during output shutoff due to a fault occurrence.)

- If the parameter for electronic bypass is not set while the commercial mode is set (**Pr.523** = "3[], 4[]"), the operation is not switched over to the commercial power supply operation even when a condition for switchover is satisfied, and the output is shut off.
- To assign the MC2 and MC3 signals to output terminals, use any two parameters from **Pr.190 to Pr.192 (Output terminal function selection)** and set "18" (positive logic) for the MC2 signal and set "19" (positive logic) for the MC3 signal.
- Operation of magnetic contactor (MC2, MC3)

Magnetic contactor	Installation location	Operation	
		During commercial power supply operation	During inverter operation
MC2	Between power supply and motor	Shorted	Open
MC3	Between inverter output side and motor	Open	Shorted

- The input signals are as follows.

Signal	Function	Operation	MC operation ^{*2}	
			MC2	MC3
X84	Emergency drive operation	ON: Emergency drive operation	—	—
		OFF: Normal operation ^{*1}	×	○
RES	Operation status reset	ON: Reset	×	Unchanged
		OFF: Normal operation	—	—

*1 The operation is not switched over to the normal operation even when the signal is turned OFF during emergency drive operation.

*2 MC operation is as follows.

Mark	MC operation
○	ON
×	OFF
—	During inverter operation: MC2-OFF, MC3-ON During commercial power supply operation: MC2-ON, MC3-OFF
Unchanged	The status remains the same after turning ON or OFF the signal.

◆ PID control during emergency drive operation

- The **Pr.524** setting is used as a set point for PID control operation during emergency drive operation in the PID control mode. Input the measured values in the method set in **Pr.128**.
- While the PID control mode is selected (**Pr.523** = "[]2[]"), if a reset is performed at the occurrence of undervoltage during emergency drive operation, the operation is performed not under PID control but with the fixed frequency. Use **Pr.1013 Running speed after recovery from emergency drive undervoltage** to set the fixed frequency.

NOTE

- Refer to [page 283](#) for details on PID control.

◆ Protective functions during emergency drive operation

- Protective functions during emergency drive operation are as follows.

Protective functions	Operation during emergency drive	Protective functions	Operation during emergency drive	Protective functions	Operation during emergency drive
E.OC1	Retry	E.LUP	The function is disabled.	E.CDO	Retry
E.OC2	Retry	E.LDN	The function is disabled.	E.IOH	Output shutoff
E.OC3	Retry	E.BE	Retry ^{*2}	E.AIE	The function is disabled.
E.OV1	Retry	E.GF	Retry	E.USB	The function is disabled.
E.OV2	Retry	E.LF	The function is disabled. ^{*1}	E.SAF	Retry ^{*2}
E.OV3	Retry	E.OHT	Retry	E.OS	The function is disabled.
E.THT	Retry	E.PTC	Retry	E.PID	The function is disabled.
E.THM	Retry	E.PE6	The function is disabled.	E.5	Output shutoff
E.FIN	Retry	E.PE	Output shutoff	E.6	Output shutoff
E.UVT	The function is disabled. ^{*1}	E.PUE	The function is disabled.	E.7	Output shutoff
E.ILF	The function is disabled. ^{*1}	E.RET	Output shutoff	E.10	Retry
E.OLT	Retry	E.PE2	Output shutoff	E.13	Retry ^{*2}
E.SOT	Retry	E.CPU	Output shutoff		

*1 If the total number of activations of a certain protective function (E.UVT, E.ILF, or E.LF) reaches the number of retries while the electronic bypass during emergency drive operation is enabled, the operation is switched over to the commercial power supply operation when the output frequency is increased/decreased to the **Pr.139** setting.

*2 If the same protective function is activated continuously while the electronic bypass during emergency drive operation is enabled, retry is performed up to twice and then operation is switched over to the commercial power supply operation.

- Fault output during emergency drive operation is as follows.

Signal	Pr.190 to Pr.196 setting		Description
	Positive logic	Negative logic	
Y65	65	165	The signal is ON during emergency drive operation.
ALM3	66	166	The signal is output when a fault occurs during emergency drive operation. When a fault which does not activate protective functions occurs during emergency drive operation, the signal is ON for three seconds and then turned OFF.

◆ Input signal operation

- During emergency drive operation in the fixed frequency mode or in the PID control mode, input signals unrelated to the emergency drive become invalid with some exceptions.
- The following table shows functions of the signals that do not become invalid during emergency drive operation in the fixed frequency mode or in the PID control mode.

Input signal status	Fixed frequency mode	PID control mode
Valid	OH, TRG, TRC, RES	OH, TRG, TRC, RES
Held	RT, X18, X84	RT, X16, X18, X64, X65, X66, X67, X84
Always-ON	—	X14

◆ Emergency drive status monitor

- Set "68" in **Pr.52, Pr.774 to Pr.776, Pr.992** to monitor the status of the emergency drive on the operation panel.
- Description of the status monitor

Operation panel indication	Description		
	Emergency drive setting	Emergency drive operating status	
0	Emergency drive function setting is not available.	—	
1	Electronic bypass during emergency drive operation is disabled.	During normal operation	
2		Emergency drive in operation	
3		Operating properly	
4		A certain alarm is occurring.*2	
5		A fault is occurring. The operation is being continued by the retry.	
10	Parameter settings for electronic bypass during emergency drive operation are enabled.	During normal operation	
11		Emergency drive in operation	
12			Operating properly
13			A certain alarm is occurring.*2
14			A fault is occurring. The operation is being continued by the retry.
15			A fault is occurring. The continuous operation is not allowed due to output shutoff.
2□ ^{*1}		Electronic bypass is started during emergency drive (during acceleration/ deceleration to the switchover frequency).	
3□ ^{*1}		During electronic bypass during emergency drive (waiting during the interlock time).	
4□ ^{*1}		During commercial power supply operation during emergency drive	

*1 The value in the ones place indicates the previous displayed value (the setting at a fault occurrence).

*2 "A certain alarm" means a protective function disabled during emergency drive shown in the tables on [page 187](#).

NOTE

- When the retry is selected (**Pr.523** = "2□□, 3□□"), it is recommended to use the automatic restart after instantaneous power failure function at the same time.
- During emergency drive operation, parameter setting, Parameter clear, All parameter clear, and Parameter copy are disabled.
- When the emergency drive function is canceled while the X84 signal is ON, "0 or 10" is displayed on the emergency drive status monitor.
- To return to the normal operation during emergency drive operation, turn OFF the start command and the X84 signal, and then do the following. (The operation will not be returned to normal only by turning OFF the X84 signal.)
Reset the inverter, or turn OFF the power.
- The operation is switched over to the commercial power supply operation in case of the following during emergency drive operation while the commercial mode or the retry / commercial mode is selected. Note that the MC2 signal is OFF at an undervoltage even when the operation is switched over to the commercial power supply operation.
At a power failure, at an undervoltage
- The emergency drive function is disabled when **Pr.30** = "2" to enable the automatic restart after instantaneous power failure function when using the multifunction regeneration converter (FR-XC) and high power factor converter (FR-HC2).
- The emergency drive function is disabled under the following conditions.
During auto tuning, when the X10 signal is assigned

CAUTION

- When the emergency drive function is enabled, the operation is continued or the retry operation (automatic reset and restart) is repeated even if a fault occurs, which may damage or burn this product and the motor. Before restarting the normal operation after emergency drive operation, make sure that this product and the motor have no fault. Any damage of the inverter or the motor caused by using the emergency drive function is not covered by the warranty even within the guarantee period.
-

« Parameters referred to »»

Pr.68 Retry waiting time  [page 179](#)

Pr.128 PID action selection  [page 283](#)

Pr.800 Control method selection  [page 72](#)

C42 (Pr.934) to C45 (Pr.935) (PID display bias/gain)  [page 297](#)

9.9 Checking faulty area in the internal storage device

When E.PE6 (Internal storage device fault) occurs, faulty area in the internal storage device can be checked by reading **Pr.890**. When the read value of **Pr.890** is "7" or smaller, an inverter reset after All parameter clear can return the operation to normal. (The parameters that had been changed before All parameter clear must be set again.)

Pr.	Name	Initial value	Setting range	Description
890 H325	Internal storage device status indication	0	(0 to 255)	A detected faulty area can be indicated in the internal storage device. (Read-only)

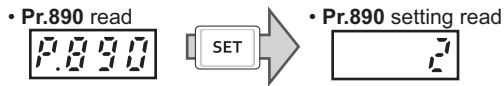

- Use the read value of **Pr.890** to check the faulty area.

The following table shows faulty areas indicated by the read value of **Pr.890**. Some read values indicate that there are multiple faulty areas. (For example, the read value "7" indicates that all the areas described in No. 1 to No. 3 are faulty.)

No.	Read value	Description
1	1, 3, 5, 7	Storage area other than the area for parameter settings is faulty (such as area for the set frequency). (When All parameter clear is performed, the set frequency, remotely-set frequency, and offline auto tuning data are cleared.)
2	2, 3, 6, 7	Storage area for standard parameter settings is faulty.
3	4, 5, 6, 7	Storage area for communication parameter settings is faulty.
4	8 to 255	Area for manufacturer setting

NOTE

- When the read value of **Pr.890** is "8 to 15", refer to the Instruction Manual (Maintenance).

9.10 Limiting the output frequency (maximum/minimum frequency)

Motor speed can be limited. Clamp the upper and lower limits of the output frequency.

Pr.	Name	Initial value	Setting range	Description
1 H400	Maximum frequency	120 Hz	0 to 120 Hz	Set the upper limit of the output frequency.
2 H401	Minimum frequency	0 Hz	0 to 120 Hz	Set the lower limit of the output frequency.
18 H402	High speed maximum frequency	120 Hz	0 to 590 Hz	Set when operating at a frequency higher than 120 Hz.

◆ Setting the maximum frequency (Pr.1, Pr.18)

- Set **Pr.1 Maximum frequency** to the upper limit of the output frequency. If the value of the frequency command given is higher than the setting, the output frequency is clamped at the maximum frequency.
- To operate at a frequency higher than the 120 Hz, adjust the upper output frequency limit with **Pr.18 High speed maximum frequency**. (When setting a frequency in **Pr.18**, the **Pr.1** setting automatically changes to the frequency set in **Pr.18**. Also, when a frequency is set in **Pr.1**, the **Pr.18** setting automatically changes to the frequency set in **Pr.1**.)

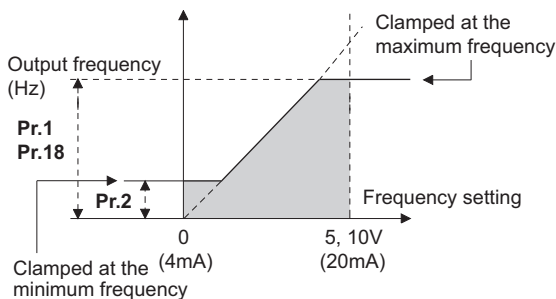

◆ Setting the minimum frequency (Pr.2)

- Set **Pr.2 Minimum frequency** to the lower limit of the output frequency.
- If the set frequency is less than the **Pr.2** setting, the output frequency is clamped at the **Pr.2** setting (does not fall below the **Pr.2** setting).

NOTE

- To operate with a frequency higher than 60 Hz using frequency-setting analog signals, change the **Pr.125 (Pr.126) (frequency setting gain)** setting. Simply changing the **Pr.1 and Pr.18** settings does not enable the operation at a frequency higher than 60 Hz.
- Under PM sensorless vector control, the upper and lower limits are for the commanded frequency. The final output frequency that is decided by each control may exceed the lower or upper limits.
- When **Pr.15 Jog frequency** is less than the **Pr.2** setting, the **Pr.15** setting takes precedence.
- If a jump frequency that exceeds the setting of **Pr.1 (Pr.18)** is set, the maximum frequency setting is the set frequency. If the jump frequency is less than the setting of **Pr.2**, the jump frequency is the set frequency. (The set frequency can be less than the minimum frequency.) When stall prevention is activated to decrease the output frequency, the output frequency may drop below the setting of **Pr.2**.

CAUTION

- Note that when **Pr.2** is set to any value equal to or higher than **Pr.13 Starting frequency**, simply turning ON the start signal runs the motor at the frequency set in **Pr.2** in accordance with the acceleration time setting even if the command frequency is not given.

« Parameters referred to »

Pr.13 Starting frequency  [page 139](#), [page 141](#)

Pr.15 Jog frequency  [page 161](#)

Pr.125 Terminal 2 frequency setting gain frequency, Pr.126 Terminal 4 frequency setting gain frequency  [page 248](#)

9.11 Avoiding machine resonance points (frequency jump)

When it is desired to avoid resonance attributable to the natural frequency of a mechanical system, these parameters allow resonant frequencies to be jumped.

Pr.	Name	Initial value	Setting range	Description
31 H420	Frequency jump 1A	9999	0 to 590 Hz, 9999	1A to 1B, 2A to 2B, 3A to 3B are frequency jumps 9999: Function disabled
32 H421	Frequency jump 1B			
33 H422	Frequency jump 2A			
34 H423	Frequency jump 2B			
35 H424	Frequency jump 3A			
36 H425	Frequency jump 3B			
552 H429	Frequency jump range	9999	0 to 30 Hz 9999	Set the jump range for the frequency jumps (6-point jump). 3-point jump

◆ 3-point frequency jump (Pr.31 to Pr.36)

- Up to three areas may be set, with the jump frequencies set to either the top or bottom point of each area.
- The settings of frequency jumps 1A, 2A, 3A are jump points, and operation is performed at these frequencies in the jump areas.

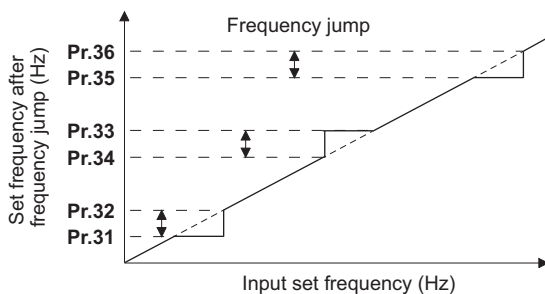

Example 1) To fix the frequency to 30 Hz in the range of 30 Hz to 35 Hz, set 35 Hz in **Pr.34** and 30 Hz in **Pr.33**.

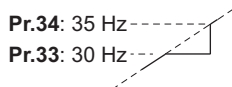

Example 2) To jump the frequency to 35 Hz in the range of 30 Hz to 35 Hz, set 35 Hz in **Pr.33** and 30 Hz in **Pr.34**.

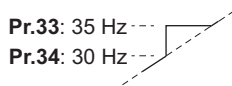

◆ 6-point frequency jump (Pr.552)

- A total of six jump areas can be set by setting the common jump range for the frequencies set in **Pr.31 to Pr.36**.
- When frequency jump ranges overlap, the lower limit of the lower jump range and the upper limit of the upper jump range are used.
- When the set frequency decreases and falls within the jump range, the upper limit of the jump range is the set frequency. When the set frequency increases and falls within the jump range, the lower limit of the jump range is the set frequency.

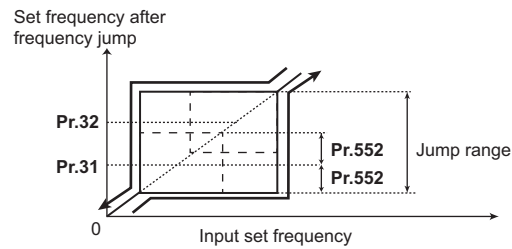
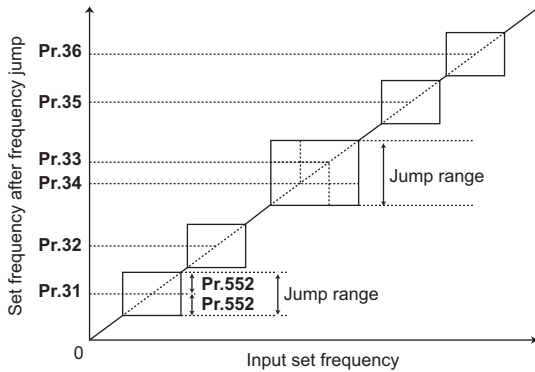

NOTE

- During acceleration/deceleration, the frequency within the set area is valid.
- If the setting ranges of individual groups (1A and 1B, 2A and 2B, 3A and 3B) overlap, Parameter write error (Er1) occurs.
- Setting **Pr.552** = "0" disables frequency jumps.
- If a jump frequency that exceeds the setting of **Pr.1 (Pr.18) Maximum frequency** is set for the 3-point frequency jump, the maximum frequency setting is the set frequency. If the jump frequency is less than the setting of **Pr.2 Minimum frequency**, the jump frequency is the set frequency. (The set frequency can be less than the minimum frequency.)

Example with 6-point frequency jump

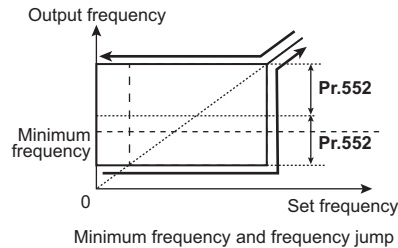
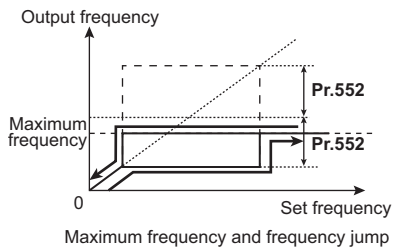

Parameters referred to

Pr.1 Maximum frequency, Pr.2 Minimum frequency, Pr.18 High speed maximum frequency [page 191](#)

9.12 Stall prevention operation



This function monitors the output current and automatically changes the output frequency to prevent the inverter from shutting off due to overcurrent, overvoltage, etc. It can also limit the stall prevention and fast-response current limit operation during acceleration/deceleration and power/regenerative driving.

This function is disabled under PM sensorless vector control.

- Stall prevention:

If the output current exceeds the stall prevention operation level, the output frequency of the inverter is automatically changed to reduce the output current. Also, the second stall prevention function can limit the output frequency range in which the stall prevention function is enabled.

- Fast-response current limit:

If the current exceeds the limit value, the output of the inverter is shut off to prevent an overcurrent.

Pr.	Name	Initial value ^{*1}		Setting range	Description
		Gr.1	Gr.2		
22 H500	Stall prevention operation level	150%		0	Stall prevention operation disabled.
				0.1% to 400% ^{*2}	Set the current limit at which the stall prevention operation starts.
156 H501	Stall prevention operation selection	0		0 to 31, 100, 101	Enable/disable the stall prevention operation and the fast-response current limit operation.
48 H600	Second stall prevention operation level	9999		0	Second stall prevention operation disabled.
				0.1% to 400% ^{*2}	The stall prevention operation level can be changed using the RT signal.
				9999	Same as Pr.22 .
23 H610	Stall prevention operation level compensation factor at double speed	9999		0% to 200%	The stall operation level when running at high speeds above the rated frequency can be reduced.
				9999	Stall prevention operation disabled at double speed.
66 H611	Stall prevention operation reduction starting frequency	60 Hz	50 Hz	0 to 590 Hz	Set the frequency at which the stall operation level reduction starts.
154 H631	Voltage reduction selection during stall prevention operation	1		1	Does not suppress the overvoltage protective function
				11	Suppresses the overvoltage protective function
157 M430	OL signal output timer	0 s		0 to 25 s	Set the OL signal output start time when stall prevention is activated.
				9999	No OL signal output.

*1 Gr.1 and Gr.2 are the parameter initial value groups. (Refer to [page 46](#).)

*2 The upper limit of stall prevention operation is limited internally to the following.
120% (SLD rating), 200% (ND rating)

◆ Setting of stall prevention operation level (Pr.22)

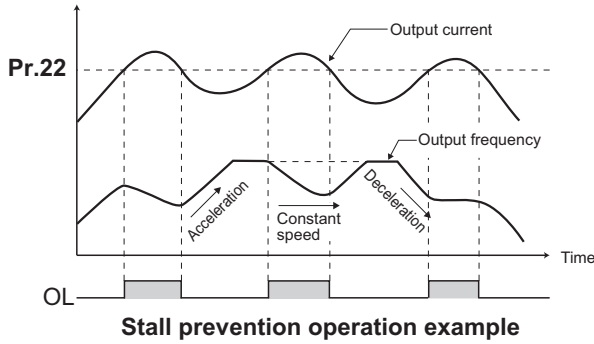

- For **Pr.22 Stall prevention operation level**, set the ratio of the output current to the inverter's rated current at which the stall prevention operation is activated. Normally, use this parameter in the initial setting.
- Stall prevention operation stops acceleration (makes deceleration) during acceleration, makes deceleration during constant speed, and stops deceleration during deceleration.
- When the stall prevention operation is performed, the Overload warning (OL) signal is output.

NOTE

- A continuous overloaded condition may activate a protective function such as motor overload trip (electronic thermal O/L relay function) (E.THM).
- When **Pr.156** has been set to activate the fast response current limit (initial value), the **Pr.22** setting should not be equal to or higher than 170%. Such setting prevents torque generation.

◆ Disabling the stall prevention operation and fast-response current limit according to operating conditions (Pr.156)

- Referring to the following table, enable/disable the stall prevention operation and the fast-response current limit operation, and also set the operation at OL signal output.

Pr.156 setting	Fast-response current limit ○: enabled ●: disabled	Stall prevention operation selection ○: enabled ●: disabled			Operation when the OL signal is output ○: continued ●: stopped ^{*1}
		Acceleration	Constant speed	Deceleration	
0 (initial value)	○	○	○	○	○
1	●	○	○	○	○
2	○	●	○	○	○
3	●	●	○	○	○
4	○	○	●	○	○
5	●	○	●	○	○
6	○	●	●	○	○
7	●	●	●	○	○
8	○	○	○	●	○
9	●	○	○	●	○
10	○	●	○	●	○
11	●	●	○	●	○
12	○	○	●	●	○
13	●	○	●	●	○
14	○	●	●	●	○
15	●	●	●	●	○ ^{*2}
16	○	○	○	○	●
17	●	○	○	○	●
18	○	●	○	○	●
19	●	●	○	○	●
20	○	○	●	○	●
21	●	○	●	○	●
22	○	●	●	○	●
23	●	●	●	○	●
24	○	○	○	●	●
25	●	○	○	●	●
26	○	●	○	●	●
27	●	●	○	●	●
28	○	○	●	●	●

Pr.156 setting	Fast-response current limit ○: enabled ●: disabled	Stall prevention operation selection ○: enabled ●: disabled			Operation when the OL signal is output ○: continued ●: stopped*1
		Acceleration	Constant speed	Deceleration	
29	●	○	●	●	●
30	○	●	●	●	●
31	●	●	●	●	●*2
100*3	Power driving	○	○	○	○
	Regenerative driving	●	●	●	○*2
101*3	Power driving	●	○	○	○
	Regenerative driving	●	●	●	○*2

- *1 When "operation stop at OL signal output" is selected, the fault output "E.OLT" (stop due to stall prevention) is displayed, and operation stops.
- *2 The OL signal and E.OLT due to fast-response current limit or stall prevention are not output because these functions are disabled. However, output of the OL signal and E.OLT due to the regeneration avoidance operation can be made. (For the regeneration avoidance function, refer to page 345.)
- *3 Setting values "100, 101" can be individually set for power driving and regenerative driving. The setting value "101" disables the fast-response current limit during power driving.

NOTE

- When the load is heavy or the acceleration/deceleration time is short, stall prevention operates and acceleration/deceleration may not be performed according to the time set. Set **Pr.156** and stall prevention operation level to the optimum values.
- For lift applications, make settings to disable the fast-response current limit. Otherwise, the torque may be insufficient, causing the load to drop.

◆ Adjusting the stall prevention operation signal and output timing (OL signal, Pr.157)

- If the output current exceeds the stall prevention operation level and stall prevention is activated, or the fast-response current limit is enabled, Overload warning (OL) signal turns ON for 100 ms or more. The output signal turns OFF when the output current falls to the stall prevention operation level or less.
- Pr.157 OL signal output timer** can be used to set whether to output the OL signal immediately, or whether to output it after a certain time period has elapsed.
- This function also operates during regeneration avoidance operation ("OLV" (overvoltage stall)).
- For the OL signal, set "3" (positive logic) or "103" (negative logic) in any parameter from **Pr.190 to Pr.196 (Output terminal function selection)** to assign the function to an output terminal.

Pr.157 setting	Description
0 (initial value)	Output immediately.
0.1 to 25	Output after the set time (s).
9999	Not output.

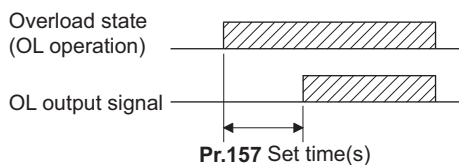

NOTE

- If the stall prevention operation has lowered the output frequency to 1 Hz and kept the level for three seconds, the stall prevention stop (E.OLT) is activated to shut off the inverter output.
- Changing the terminal assignment using **Pr.190 to Pr.196 (Output terminal function selection)** may affect the other functions. Set parameters after confirming the function of each terminal.

◆ Setting for stall prevention operation in the high-frequency range (Pr.22, Pr.23, Pr.66)

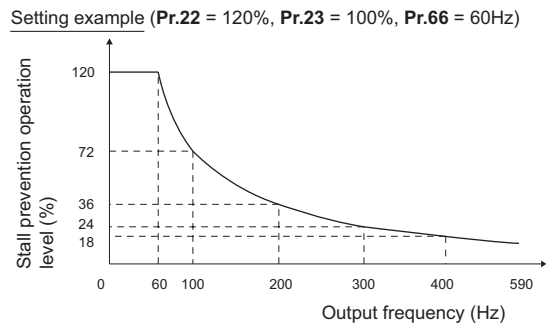
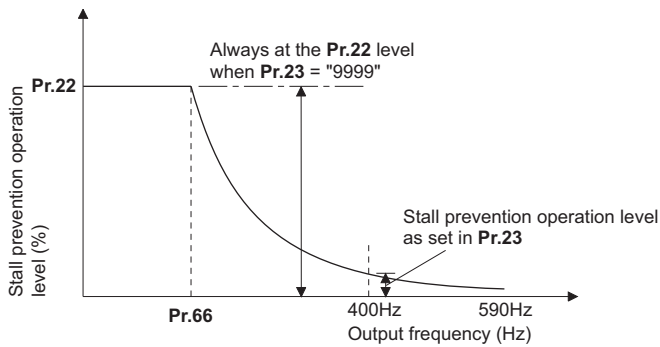

- When operating at high speeds above the rated motor frequency, acceleration may not be made as the motor current does not increase. Also, when operating in the high-frequency range, the current flowing to the locked motor becomes less than the rated output current of the inverter. Even if the motor is stopped, the protective function does not operate (OL). In a case like this, the stall prevention level can be reduced in the high-frequency range to improve the motor's operating characteristics. This is useful when operating up to the high speed range, such as when using a centrifuge. Normally, set **Pr.66 Stall prevention operation reduction starting frequency** to 60 Hz, and **Pr.23 Stall prevention operation level compensation factor at double speed** to 100%.

- Calculation formula for stall prevention operation level

$$\text{Stall prevention operation level (\%)} = A + B \times \left[\frac{\text{Pr.22} - A}{\text{Pr.22} - B} \right] \times \left[\frac{\text{Pr.23} - 100}{100} \right]$$

in the high-frequency range

$$\text{Where, } A = \frac{\text{Pr.66 (Hz)} \times \text{Pr.22 (\%)}}{\text{Output frequency (Hz)}}, B = \frac{\text{Pr.66 (Hz)} \times \text{Pr.22 (\%)}}{400 \text{ Hz}}$$

- When Pr.23 = "9999 (initial value)", the stall prevention operation level is constant at the Pr.22 level up to 590 Hz.

◆ Setting two stall prevention operation levels (Pr.48)

- **Pr.48 Second stall prevention operation level** is enabled when the RT signal is ON.
- To input the RT signal, set "3" in any parameter from **Pr.178 to Pr.182** and **Pr.185 to Pr.189 (Input terminal function selection)** to assign the function.

NOTE

- Changing the terminal assignment using **Pr.178 to Pr.182** and **Pr.185 to Pr.189 (Input terminal function selection)** may affect the other functions. Set parameters after confirming the function of each terminal.
- The RT signal is the Second function selection signal which also enables other second functions. (Refer to [page 257](#).)

◆ Further prevention of a trip (Pr.154)

- Set **Pr.154** = "11" when the overvoltage protective function (E.OV[]) is activated during stall prevention operation in an application with large load inertia. Note that turning OFF the start signal (STF/STR) or varying the frequency command during stall prevention operation may delay the acceleration/deceleration start.

CAUTION

- Do not set the stall prevention operation current too low.
Doing so will reduce the generated torque.
 - Be sure to perform the test operation.
Stall prevention operation during acceleration may extend the acceleration time.
Stall prevention operation during constant-speed operation may cause sudden speed changes.
Stall prevention operation during deceleration may extend the deceleration time.
-

« Parameters referred to »

Pr.22 Torque limit level  [page 87](#)

Pr.178 to Pr.182 and Pr.185 to Pr.189 (Input terminal function selection)  [page 252](#)

Pr.190 to Pr.196 (Output terminal function selection)  [page 226](#)

9.13 Load characteristics fault detection

This function is used to monitor whether the load is operating in normal condition by storing the speed/torque relationship in the inverter to detect mechanical faults or for maintenance. When the load operating condition deviates from the normal range, the protective function is activated or the warning is output to protect the inverter or the motor.

Pr.	Name	Initial value ^{*1}		Setting range	Description
		Gr.1	Gr.2		
1480 H520	Load characteristics measurement mode	0		0	Load characteristics measurement mode does not start. (Measurement of load characteristics complete without fault.)
				1	Load characteristics measurement mode is started.
				(2 to 5, 81 to 85)	The load characteristics measurement status is displayed. (Read-only)
1481 H521	Load characteristics load reference 1	9999		0% to 400%	Used to set the reference value of normal load characteristics. 8888: The present load status is written as reference status. 9999: The load reference is invalid.
1482 H522	Load characteristics load reference 2	9999			
1483 H523	Load characteristics load reference 3	9999			
1484 H524	Load characteristics load reference 4	9999			
1485 H525	Load characteristics load reference 5	9999			
1486 H526	Load characteristics maximum frequency	60 Hz	50 Hz	0 to 590 Hz	Used to set the upper frequency limit of the load characteristics fault detection range.
1487 H527	Load characteristics minimum frequency	6 Hz		0 to 590 Hz	Used to set the lower frequency limit of the load characteristics fault detection range.
1488 H531	Upper limit warning detection width	20%		0% to 400%	Used to set the detection range of when the upper limit load fault warning is output.
				9999	Function disabled
1489 H532	Lower limit warning detection width	20%		0% to 400%	Used to set the detection range of when the lower limit load fault warning is output.
				9999	Function disabled
1490 H533	Upper limit fault detection width	9999		0% to 400%	Used to set the detection range of when output is shut-off when the upper limit load fault occurs.
				9999	Function disabled
1491 H534	Lower limit fault detection width	9999		0% to 400%	Used to set the detection range of when output is shut-off when the lower limit load fault occurs.
				9999	Function disabled
1492 H535	Load status detection signal delay time / load reference measurement waiting time	1 s		0 to 60 s	Used to set the waiting time after the load fault is detected until warning output or output shutoff. In the load characteristics measurement mode, set the waiting time after the load measurement frequency is reached until the load reference is set.

*1 Gr.1 and Gr.2 are the parameter initial value groups. (Refer to [page 46.](#))

◆ Load characteristics reference setting (Pr.1481 to Pr.1487)

- Use **Pr.1481 to Pr.1485** to set the reference value of load characteristics.
- Use **Pr.1486 Load characteristics maximum frequency** and **Pr.1487 Load characteristics minimum frequency** to set the output frequency range for load fault detection.

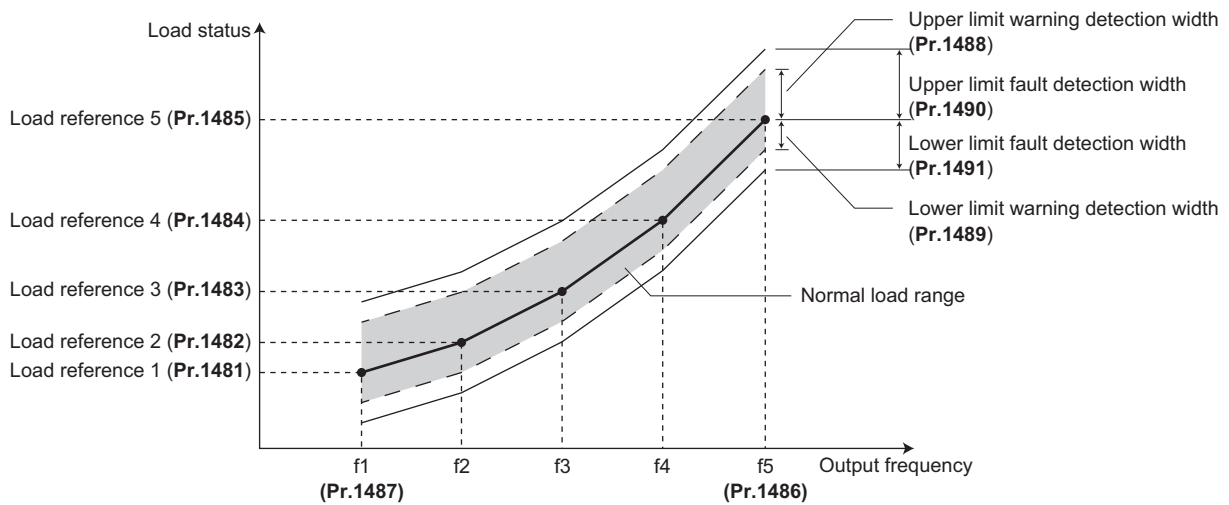

◆ Automatic measurement of the load characteristics reference (Load characteristics measurement mode) (Pr.1480)

Point

- Perform measurement under actual environment with the motor connected.
 - Set **Pr.1487 Load characteristics minimum frequency** to a value higher than the **Pr.13 Starting frequency** setting.
- Setting **Pr.1480 Load characteristics measurement mode** = "1" enables automatic measurement of the load characteristics reference. (Load characteristics measurement mode)
 - Use **Pr.1486 and Pr.1487** to set the frequency band for the measurement, and set **Pr.1480** = "1". After setting, when the inverter is started, the measurement starts. (When the value set in **Pr.1486** is equal to or smaller than the value set in **Pr.1487**, the measurement does not start.)
 - The automatically measured load characteristics reference is written in **Pr.1481 to Pr.1485**.
 - After the measurement is started, read **Pr.1480** to display the status of the measurement. If "8" appears in the tens place, the measurement has not properly completed.

Read value of Pr.1480		Status
Tens place	Ones place	
—	1	During measurement from the starting point to Point 1
—	2	During measurement from Point 1 to Point 2
—	3	During measurement from Point 2 to Point 3
—	4	During measurement from Point 3 to Point 4
—	5	During measurement from Point 4 to Point 5
—	0	Normal completion
8	1 to 5	Termination of measurement by an activation of a protective function, inverter reset, turning ON of MRS signal, turning OFF of the start command, or timeout. (The value in the ones place represents the above-mentioned measurement point.)

- While measuring automatically, the During load characteristics measurement (Y213) signal is output. For the Y213 signal, set "213" (positive logic) or "313" (negative logic) in any parameter from **Pr.190 to Pr.196 (Output terminal function selection)** to assign the function.
- Setting "8888" in **Pr.1481 to Pr.1485** enables fine adjustment of load characteristics. When setting **Pr.1481 to Pr.1485** = "8888" during operation, the load status at that point is set in the parameter (only when the set frequency is within ± 2 Hz of the frequency of the measurement point, and the SU signal is ON).

Example of starting measurement from the stop state

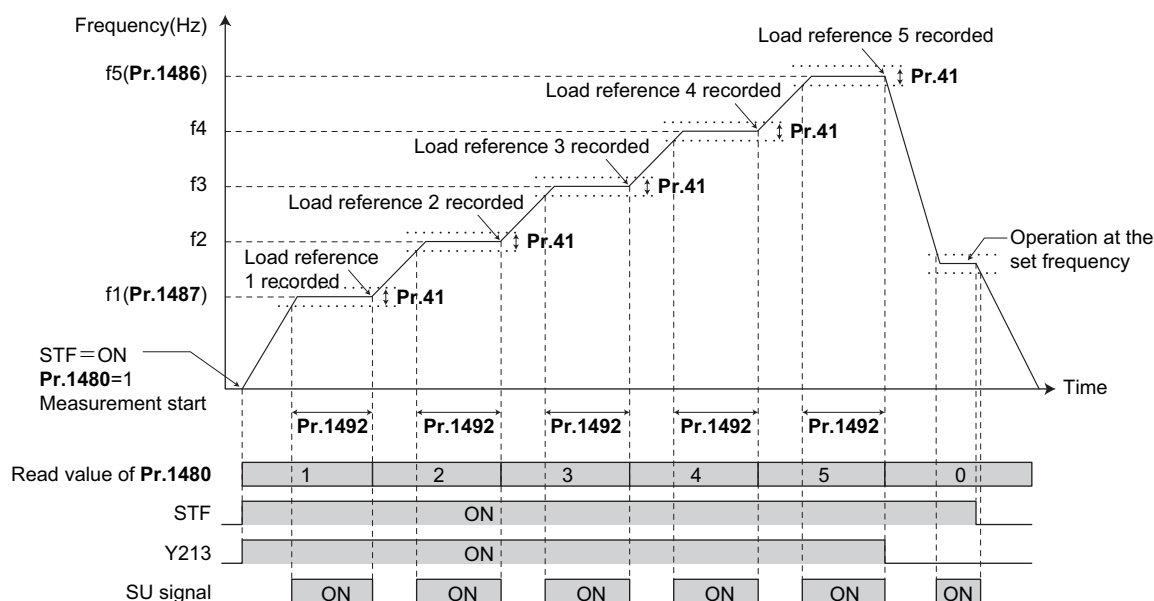

NOTE

- Even if the load measurement is not properly completed, the load characteristics fault is detected based on the load characteristics found by the already-completed portion of the measurement.
- During the load characteristics measurement, the load characteristics fault detection is not performed.
- During the load characteristics measurement, linear acceleration/deceleration is performed even if the S-pattern acceleration/deceleration is set.
- Changing the terminal assignment using **Pr.190 to Pr.196 (Output terminal function selection)** may affect the other functions. Set parameters after confirming the function of each terminal.

◆ Setting the load characteristics reference manually (Pr.1481 to Pr.1485)

- Set **Pr.1480 Load characteristics measurement mode** = "0 (initial value)".
- Set **Pr.1486 and Pr.1487** to specify the frequency band for the measurement, and calculate the frequency as the load characteristics reference (f_2 to f_4) using the following table.
- Start the inverter operation, and set **Pr.1481** = "8888" during operation at the frequency of the load characteristics reference 1 (f_1). The load status at that point is set in **Pr.1481** (only when the set frequency is within ± 2 Hz of the frequency of the measurement point, and the SU signal is ON).
- Set load references in **Pr.1482 to Pr.1485** in the same way as **Pr.1481**.

Reference	Frequency	Load reference
Load characteristics reference 1	f_1 : load characteristics minimum frequency (Pr.1487)	Pr.1481
Load characteristics reference 2	$f_2 = (f_5 - f_1)/4 + f_1$	Pr.1482
Load characteristics reference 3	$f_3 = (f_5 - f_1)/2 + f_1$	Pr.1483
Load characteristics reference 4	$f_4 = (f_5 - f_1) \times 3/4 + f_1$	Pr.1484
Load characteristics reference 5	f_5 : load characteristics maximum frequency (Pr.1486)	Pr.1485

NOTE

- When inputting values directly in **Pr.1481 to Pr.1485** under V/F control, input the load meter monitored values at the frequency of each load characteristics reference.
- When inputting values directly in **Pr.1481 to Pr.1485** under Advanced magnetic flux vector control or PM sensorless vector control, input the motor torque value monitored at the frequency of each load characteristics reference.

◆ Setting example

- The load characteristics are calculated from the parameter setting and the output frequency.
- A setting example is as follows. The reference value is linearly interpolated from the parameter settings. For example, the reference when the output frequency is 30 Hz is 26%, which is linearly interpolated from values of the reference 2 and the reference 3.

Reference	Frequency	Load reference
Load characteristics reference 1	f1: load characteristics minimum frequency (Pr.1487) = 10 Hz	Pr.1481 = 15%
Load characteristics reference 2	f2 = (f5 - f1)/4 + f1 = 22.5 Hz	Pr.1482 = 20%
Load characteristics reference 3	f3 = (f5 - f1)/2 + f1 = 35 Hz	Pr.1483 = 30%
Load characteristics reference 4	f4 = (f5 - f1) × 3/4 + f1 = 47.5 Hz	Pr.1484 = 60%
Load characteristics reference 5	f5: load characteristics maximum frequency (Pr.1486) = 60 Hz	Pr.1485 = 100%

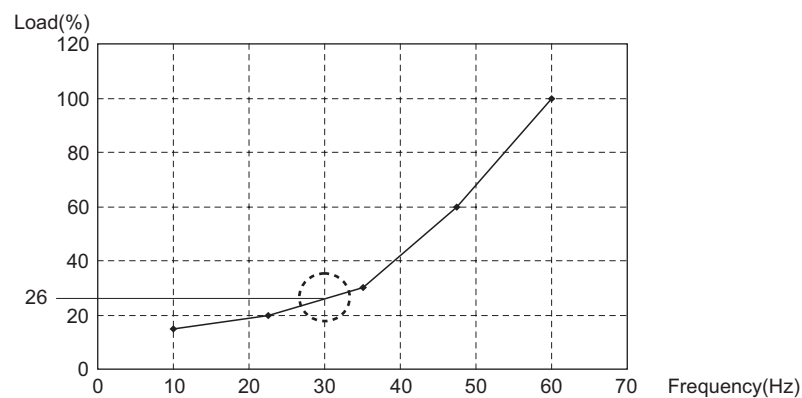

NOTE

- When the load reference is not set for five points, the load characteristics value is determined by linear interpolation of the set load reference values only. If there is only one load reference setting, the set load reference is used as the load reference all through the range.

◆ Load fault detection setting (Pr.1488 to Pr.1491)

- When the load is deviated from the detection width set in **Pr.1488 Upper limit warning detection width**, the Upper limit warning detection (LUP) signal is output. When the load is deviated from the detection width set in **Pr.1489 Lower limit warning detection width**, the Lower limit warning detection (LDN) signal is output. At the same time, the Load fault warning (LDF) appears on the operation panel.
- For the LUP signal output, set "211" (positive logic) or "311" (negative logic) in any parameter from **Pr.190 to Pr.196 (Output terminal function selection)**. For the LDN signal, set "212" (positive logic) or "312" (negative logic).
- When the load is deviated from the detection width set in **Pr.1490 Upper limit fault detection width**, the protective function (E.LUP) is activated and the inverter output is shut off. When the load is deviated from the detection width set in **Pr.1491 Lower limit fault detection width**, the protective function (E.LDN) is activated and the inverter output is shut off.
- To prevent the repetitive on/off operation of the signal due to load fluctuation near the detection range, **Pr.1492 Load status detection signal delay time / load reference measurement waiting time** can be used to set the delay time. Even when a fault is detected out of the detection range once, the warning is not output if the characteristics value returns to the normal range from a fault state within the output delay time.

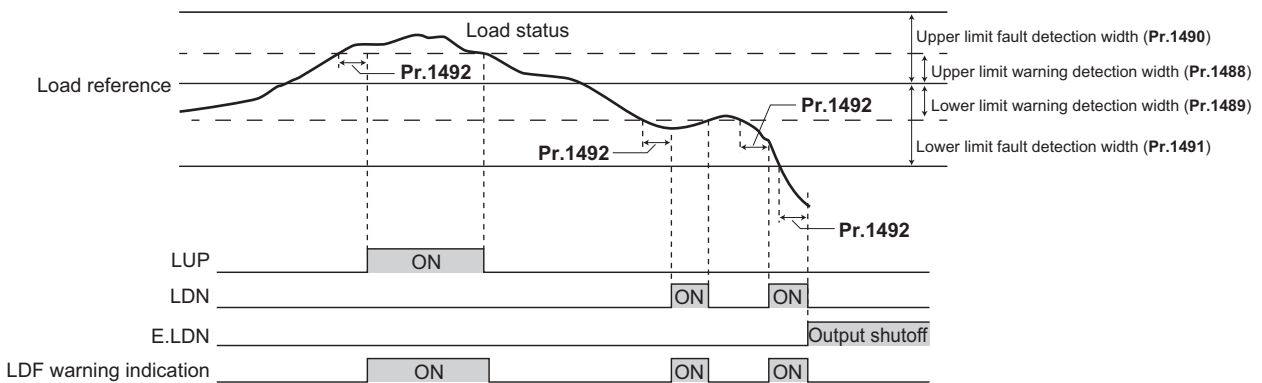

NOTE

- Changing the terminal assignment using **Pr.190 to Pr.196 (Output terminal function selection)** may affect the other functions. Set parameters after confirming the function of each terminal.

Parameters referred to

Pr.41 Up-to-frequency sensitivity [page 234](#)

Pr.190 to Pr.196 (Output terminal function selection) [page 226](#)

9.14 Motor overspeeding detection



The Overspeed occurrence (E.OS) is activated when the output frequency exceeds the overspeed detection level. This function prevents the motor from accidentally speeding over the specified value, due to an error in parameter setting, etc.

Pr.	Name	Initial value	Setting range	Description
374 H800	Overspeed detection level	9999	0 to 400 Hz	If the output frequency exceeds the value set in Pr.374, Overspeed occurrence (E.OS) occurs, and the inverter output is shut off.
			9999	E.OS occurs when the frequency exceeds the value calculated by adding 10 Hz to the maximum motor frequency ^{*1} .

*1 The maximum motor frequency is set in Pr.702 Maximum motor frequency. When Pr.702 = "9999 (initial value)", the value set in Pr.84 Rated motor frequency is used as the maximum motor frequency.

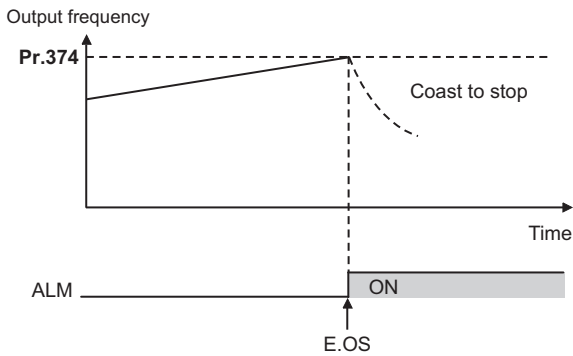

10 (M) Item and Output Signal for Monitoring

Purpose	Parameter to set			Refer to page
To display the motor speed (the number of rotations per minute) To switch the unit of measure to set the operation speed from frequency to motor speed	Speed indication and its setting change to rotations per minute	P.M000, P.M001, P.M003	Pr.37, Pr.53, Pr.505	206
To change the item monitored on the operation panel and parameter unit	Operation panel monitor item selection Clearing the cumulative value during monitoring	P.M020 to P.M023, P.M030, P.M031, P.M050 to P.M052, P.M100 to P.M104	Pr.52, Pr.170, Pr.171, Pr.268, Pr.563, Pr.564, Pr.774 to Pr.776, Pr.891, Pr.992, Pr.1106 to Pr.1108	208
To change the monitor item whose data is output via terminal AM	Terminal AM function selection	P.M040 to P.M042, P.M301	Pr.55, Pr.56, Pr.158, Pr.866	216
To adjust the output via terminal AM	Terminal AM calibration	P.M320, P.M390	C1 (Pr.901), Pr.1200	218
To check the effects of energy saving	Energy saving monitoring	P.M023, P.M100, P.M200 to P.M207, P.M301	Pr.52, Pr.158, Pr.891 to Pr.899	219
To assign functions to the output terminals	Output terminal function assignment	P.M400, P.M404, P.M405, P.M431, P.M451 to P.M454	Pr.190 to Pr.196, Pr.289	226
To detect the output frequency	Up-to-frequency sensitivity Output frequency detection Low speed detection	P.M440 to P.M443, P.M446	Pr.41 to Pr.43, Pr.865, Pr.870	234
To detect the output current	Output current detection Zero current detection	P.M433, P.M460 to P.M464	Pr.150 to Pr.153, Pr.166, Pr.167	237
To use the remote output function	Remote output	P.M500, P.M501	Pr.495, Pr.496	239
To detect the specified output power	Pulse train output of output power	P.M520	Pr.799	241
To detect the control circuit temperature	Control circuit temperature monitoring	P.M060	Pr.663	242

10.1 Speed indication and its setting change to rotations per minute

The frequency monitored or set on the operation panel can be changed to the motor speed or the machine speed.

Pr.	Name	Initial value ^{*1}		Setting range	Description
		Gr.1	Gr.2		
37 M000	Speed display	1800		0.01 to 9998 ^{*2}	Set a number for the speed of machine operated at the speed (frequency) set in Pr.505 .
53 M003	Frequency / rotation speed unit switchover	0		0	Frequency displayed
				1	Rotation speed displayed
				4	Machine speed displayed
505 M001	Speed setting reference	60 Hz	50 Hz	1 to 590 Hz ^{*2}	Set the reference speed (frequency) for Pr.37 .

*1 Gr.1 and Gr.2 are the parameter initial value groups. (Refer to [page 46](#).)

*2 The setting ranges of **Pr.1 (Pr.18)**, **Pr.37**, and **Pr.505** are limited so that the following formula is satisfied.
 $Pr.1 (Pr.18) \times Pr.37 / Pr.505 < 8388.607$

The setting range of **Pr.1 (Pr.18)** is not limited when the machine speed display is not selected. To display the machine speed, set values which satisfy the formula.

◆ Displayed unit switchover (Pr.37, Pr.53, and Pr.505)

- The rotation speed or machine speed can be displayed for monitoring or used for parameter setting instead of the frequency by using **Pr.53**.
- To display the machine speed, set **Pr.37** to the value which corresponds to the speed of machine operated at the frequency set in **Pr.505**.

For example, when **Pr.505** is set to 60 Hz and **Pr.37** is set to "1000", the operation panel indicates "1000" as the monitor value of machine speed while the output frequency is 60 Hz. "500" is displayed while the output frequency is 30 Hz.

- The operation panel indicates the upper 4 digits when the rotation speed or machine speed is displayed. For example, when the internal value "1770.950" is monitored, the operation panel indicates "1770".

Pr.53 setting	Output frequency indication	Set frequency indication Dancer main speed setting indication	Running speed indication	Frequency setting	Parameter setting
0 (initial value)	0.01 Hz	0.01 Hz	1 r/min ^{*1}	0.01 Hz	0.01 Hz
1	1 r/min ^{*1}	1 r/min ^{*1}	1 r/min ^{*1}	1 r/min ^{*1}	1 r/min ^{*1}
4	0.001 (machine speed ^{*1})	0.001 (machine speed ^{*1})	1 (machine speed ^{*1})	0.001 (machine speed ^{*1})	0.01 Hz

*1 Motor speed r/min conversion formula: frequency × 120 / number of motor poles (**Pr.81**)

Machine speed conversion formula: **Pr.37** × Frequency / **Pr.505**

The item set in **Pr.505** is consistently a frequency (Hz).

When **Pr.81** = "9999", the number of motor poles is regarded as 4.

NOTE

- The inverter's output frequency is displayed as synchronous speed under V/F control. The displayed value is "actual motor speed" + "motor slip". When Advanced magnetic flux vector control or PM sensorless vector control is selected, the actual motor speed (estimated value by motor slip calculation) is used.
- To change the main monitor of the operation panel (operation panel main display), refer to **Pr.52**.
- Since the panel display of the operation panel or enclosure surface operation panel (FR-PA07) is in 4 digits, the monitor value of more than "9999" is displayed as "----". Display the frequency on the operation panel when a value equal to or more than 10000 r/min needs to be monitored or set.
- The displayed machine speed is the value converted from the frequency. Therefore, the setting value and read value may fluctuate due to rounding during the conversion.
- When using the machine speed display for the parameter unit (FR-PU07), do not change the speed with the up/down key if a set speed above 65535 is displayed. The set speed may become an undetermined value.
- For details on the displayed unit switchover when a communication protocol is used, refer to the Instruction Manual (Communication).

⚠ CAUTION

- Make sure to set the running speed and the number of motor poles.
- Otherwise, the motor might run at extremely high speed, damaging the machine.

Parameters referred to

Pr.1 Maximum frequency  page 191

Pr.52 Operation panel main monitor selection  page 208

Pr.81 Number of motor poles  page 72

Pr.800 Control method selection  page 72

10.2 Monitor item selection on operation panel or via communication

The monitor item to be displayed on the operation panel or the parameter unit can be selected.

Pr.	Name	Initial value	Setting range	Description
52 M100	Operation panel main monitor selection	0 (output frequency)	0, 5 to 14, 17, 18, 20, 23 to 25, 32, 33, 37, 38, 44, 50 to 55, 61, 62, 64, 67, 68, 91, 97, 98, 100	Select the monitor item to be displayed on the operation panel or parameter unit. Refer to page 209 for the monitor item selection.
774 M101	Operation panel monitor selection 1	9999	1 to 3, 5 to 14, 17, 18, 20, 23 to 25, 32, 33, 37, 38, 44, 50 to 55, 61, 62, 64, 67, 68, 91, 97, 98, 100, 9999	Each of the initial monitor items displayed on the operation panel or parameter unit in the monitor mode (output frequency, output current, and output voltage) can be switched to a user-designated item. 9999: Follows the Pr.52 setting.
775 M102	Operation panel monitor selection 2			
776 M103	Operation panel monitor selection 3			
992 M104	Operation panel setting dial push monitor selection	0 (set frequency)	0 to 3, 5 to 14, 17, 18, 20, 23 to 25, 32, 33, 37, 38, 44, 50 to 55, 61, 62, 64, 67, 68, 91, 97, 98, 100	Select the monitor item displayed on the operation panel at the time when the setting dial is pressed.
170 M020	Watt-hour meter clear	9999	0	Set "0" to clear the watt-hour meter.
			10	Set "10" to monitor the cumulative power in the range of 0 to 9999 kWh via communication.
			9999	Set "9999" to monitor the cumulative power in the range of 0 to 65535 kWh via communication.
563 M021	Energization time carrying-over times	0	(0 to 65535)	The number of times that the cumulative energization time exceeded 65535 hours is displayed (read-only).
268 M022	Monitor decimal digits selection	9999	0	Value is displayed in 1 increments (an integer).
			1	Value is displayed in 0.1 increments.
			9999	No function
891 M023	Cumulative power monitor digit shifted times	9999	0 to 4	Set the number of digits to move the decimal point of the cumulative energy monitored value to the left. The readout peaks out at the upper limit of readout.
			9999	The function of moving the decimal point is not available. The readout is reset to 0 when it exceeds the upper limit.
171 M030	Operation hour meter clear	9999	0	Set "0" to clear the operation hour meter.
			9999	The read value is always "9999". Nothing changes when "9999" is set.
564 M031	Operating time carrying-over times	0	(0 to 65535)	The number of times that the operating time reaches 65535 hours is displayed. Read-only.
1106 M050	Torque monitor filter	9999	0 to 5 s	The filter time constant is selectable for monitoring of the torque. A larger setting results in slower response.
			9999	0.3 s filter
1107 M051	Running speed monitor filter	9999	0 to 5 s	The filter time constant is selectable for monitoring of the running speed. A larger setting results in slower response.
			9999	0.08 s filter
1108 M052	Excitation current monitor filter	9999	0 to 5 s	The filter time constant is selectable for monitoring of the motor excitation current. A larger setting results in slower response.
			9999	0.3 s filter

◆ Monitor item list (Pr.52, Pr.774 to Pr.776, Pr.992)

- Use **Pr.52, Pr.774 to Pr.776, or Pr.992** to select the monitor item to be displayed on the operation panel or the parameter unit.
- Refer to the following table to find the setting value for each monitoring. The value in the Pr. setting column is set in each of the parameters for monitoring (**Pr.52, Pr.774 to Pr.776, and Pr.992**) to determine the monitored item. The value in the Communication column is the monitor code for communication. (The items marked with "—" cannot be selected.)

Monitor item	Increment and unit	Pr. setting	Communication		Description
			Monitor code 1 ^{*1}	Monitor code 2 ^{*2}	
Output frequency (speed) ^{*12}	0.01 Hz ^{*11}	1/0/100	H01	40201	The inverter output frequency is displayed.
Output current ^{*7*8*12}	0.01 A	2/0/100	H02	40202	The inverter output current effective value is displayed.
Output voltage ^{*7*12}	0.1 V	3/0/100	H03	40203	The inverter output voltage is displayed.
Fault indication	—	0/100	—	—	Each of the last 10 faults is displayed individually.
Set frequency / motor speed setting	0.01 Hz ^{*11}	5 ^{*3}	H05	40205	The set frequency is displayed.
Operation speed	1 r/min ^{*11}	6 ^{*3}	H06	40206	The motor speed (number of rotations per minute) is displayed.
Motor torque	0.1%	7 ^{*3}	H07	40207	The motor torque is displayed as a percentage (0% under V/F control), considering the rated torque as 100%.
Converter output voltage ^{*7}	0.1 V	8 ^{*3}	H08	40208	The DC bus voltage value is displayed.
Regenerative brake duty	0.1%	9 ^{*3}	H09	40209	The brake duty is displayed as a percentage, considering Pr.70 setting value as 100%. (When Pr.30 = "0", Pr.70 is disabled.)
Electronic thermal O/L relay load factor	0.1%	10 ^{*3}	H0A	40210	The motor thermal load factor or inverter thermal load factor, whichever is larger, is displayed, considering the thermal operation level as 100%.
Output current peak value ^{*7}	0.01 A	11 ^{*3}	H0B	40211	The peak value of output current, which is constantly stored, is displayed. (It is reset with every startup of the inverter.)
Converter output voltage peak value ^{*7}	0.1 V	12 ^{*3}	H0C	40212	The DC bus voltage peak value, which is constantly stored, is displayed. (It is reset with every startup of the inverter.)
Input power	0.01 kW	13 ^{*3}	H0D	40213	The power at the inverter input side is displayed.
Output power ^{*8}	0.01 kW	14 ^{*3}	H0E	40214	The power at the inverter output side is displayed.
Load meter	0.1%	17	H11	40217	Torque current is displayed as a percentage, considering Pr.56 setting value as 100%. (0% is displayed under the control mode other than V/F control.)
Motor excitation current ^{*7}	0.01 A	18	H12	40218	The motor excitation current is displayed.
Cumulative energization time ^{*4}	1 h	20	H14	40220	The cumulative energization time since the inverter shipment is displayed. The number of times an integrated value has reached the maximum value of 65535 hours can be checked in Pr.563 .
Actual operation time ^{*4*5}	1 h	23	H17	40223	The cumulative operation time is displayed. The number of times an integrated value has reached the maximum value of 65535 hours can be checked in Pr.564 . Use Pr.171 to reset it. (Refer to page 214 .)
Motor load factor	0.1%	24	H18	40224	The output current value is displayed as a percentage, considering the inverter rated current value as 100%. Readout (%) = present output current value / inverter rated current value × 100
Cumulative energy ^{*7}	0.01 kWh ^{*6}	25	H19	40225	The cumulative energy based on the monitored output power is displayed. Use Pr.170 to reset it. (Refer to page 213 .)
Torque command	0.1%	32	H20	40232	The torque command value adjusted with Vector control is displayed.
Torque current command	0.1%	33	H21	40233	The command value of the current for torque is displayed.
Heat sink temperature	1°C	37	H25	40237	The heat sink temperature is displayed.
Trace status	1	38	H26	40238	The trace status is displayed. (Refer to page 320 .)

Monitor item	Increment and unit	Pr. setting	Communication		Description
			Monitor code 1 ^{*1}	Monitor code 2 ^{*2}	
Station number (RS-485 communication)	1	44	H2C	40244	The station number of the inverter enabling RS-485 communication is displayed.
Energy saving effect	Increment and unit vary depending on the parameter settings.	50	H32	40250	The energy saving effect monitoring is enabled. The item to monitor is selectable from among the saved power, the average power saving, the power cost savings, and CO ₂ emission reduction. Some of them can be displayed as a percentage according to the parameter settings. (Refer to page 219 .)
Cumulative energy saving		51	H33	40251	
PID set point	0.1%	52	H34	40252	The set point, measured value, and deviation during PID control operation is displayed. (Refer to page 292 .)
PID measured value	0.1%	53	H35	40253	
PID deviation	0.1%	54	H36	40254	
Input terminal status	—	55 ^{*13}	H0F ^{*9}	40215 ^{*9}	The ON/OFF state of the input terminals on the inverter is displayed. (Refer to page 213 for details of indication on the operation panel.)
Output terminal status	—		H10 ^{*10}	40216 ^{*10}	The ON/OFF state of the output terminals on the inverter is displayed. (Refer to page 213 for details of indication on the operation panel.)
Motor thermal load factor	0.1%	61	H3D	40261	The accumulated heat value of the motor thermal O/L relay is displayed. The Motor overload trip (electronic thermal O/L relay function) (E.THM) occurs at 100%.
Inverter thermal load factor	0.1%	62	H3E	40262	The accumulated heat value of the inverter thermal O/L relay is displayed. The Inverter overload trip (electronic thermal O/L relay function) (E.THT) occurs at 100%.
PTC thermistor resistance	0.01 kΩ	64	H40	40264	The PTC thermistor resistance is displayed when Pr.561 PTC thermistor protection level ≠ "9999". (The output voltage is displayed when Pr.561 = "9999".)
PID measured value 2	0.1%	67	H43	40267	The PID measured value is displayed while the PID control is enabled (Pr.128 ≠ "0"), even if PID control operating conditions are not satisfied. (Refer to page 292 .)
Emergency drive status	1	68	H44	40268	Emergency drive status is displayed. (Refer to page 182 .)
32-bit cumulative energy (lower 16 bits)	1 kWh	—	H4D	40277	The upper or lower 16 bits of the 32-bit cumulative energy is displayed on each indication. Monitoring via communication is available.
32-bit cumulative energy (upper 16 bits)	1 kWh	—	H4E	40278	
32-bit cumulative energy (lower 16 bits)	0.01 kWh	—	H4F	40279	
32-bit cumulative energy (upper 16 bits)	0.01 kWh	—	H50	40280	
PID manipulated amount	0.1%	91	H5B	40291	The PID control manipulated amount is displayed. (Refer to page 292 .)
Dancer main set speed	0.01 Hz ^{*11}	97	H61	40297	The set speed for main speed during the dancer control operation is displayed.
Control circuit temperature	1°C	98	H62	40298	The temperature of the control circuit board is displayed. (Refer to page 242 .)

- *1 The monitor code is used for the Mitsubishi inverter protocol.
- *2 The monitor code is used for the MODBUS RTU.
- *3 To monitor the item on the LCD operation panel (FR-LU08) or the parameter unit (FR-PU07) in the monitor mode, use **Pr.774 to Pr.776** or the monitor function of the FR-LU08 or the FR-PU07 for setting.
- *4 The cumulative energization time and actual operation time are accumulated from 0 to 65535 hours, then cleared, and accumulated again from 0.
- *5 The actual operation time does not increase if the cumulative running time before power OFF is less than an hour.
- *6 On the parameter unit (FR-PU07), the unit "kW" is displayed.
- *7 Since the panel display of the operation panel or enclosure surface operation panel (FR-PA07) is in 4 digits, the monitor value of more than "9999" is displayed as "----".
- *8 The inverter regards the output current which is less than the specified current level (5% of the rated inverter current) as 0 A. Therefore, each readout of an output current and output power may show "0" if a too small-capacity motor is used as contrasted with the inverter capacity and the output current falls below the specified value.
- *9 The details of bits for the input terminal status are as follows. (1: ON state, 0: OFF state of a terminal on the inverter. "-" denotes an indefinite (null) value.)

b15														b0			
-	-	-	-	-	-	-	-	-	-	-	RH	RM	RL	-	-	STR	STF

- *10 The details of bits for the output terminal status are as follows. (1: ON state, 0: OFF state of a terminal on the inverter. "-" denotes an indefinite (null) value.)

b15														b0			
-	-	-	-	-	-	-	-	-	So(SO)	-	ABC	FU	-	-	-	-	RUN

- *11 The increment varies depending on the **Pr.53** setting. (Refer to [page 206](#).)
- *12 The monitored values are retained even if an inverter fault occurs. Resetting clears the retained values.
- *13 Parameter setting is not available for setting the item as the main monitor item on the LCD operation panel (FR-LU08) or the parameter unit (FR-PU07). Use the monitor function of the FR-LU08 or the FR-PU07 for setting.

◆ Monitor display for operation panel (Pr.52, Pr.774 to Pr.776)

- When **Pr.52** = "0" (initial value), the monitoring of output frequency, output current, output voltage, and fault display can be selected in sequence by pressing the SET key.
- Among the items set in **Pr.52**, the load meter, motor excitation current, and motor load factor are displayed in the second screen (initially set to monitor the output current). Other items are displayed in the third screen (initially set to monitor the output voltage).
- The first screen (initially set to monitor the output frequency) is displayed at power-ON in the initial setting. To change the screen displayed at power-ON, display the screen you want to display at power-ON, and hold down the SET key for one second. To monitor the output frequency again, display the screen of output frequency, and hold down the SET key for one second.

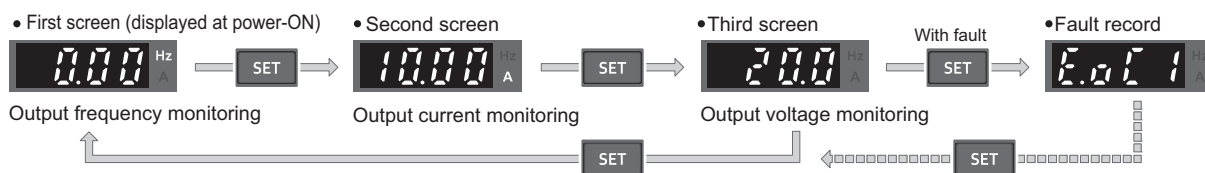

The following is the screen flow diagram when **Pr.52** = "20" (cumulative energization time).

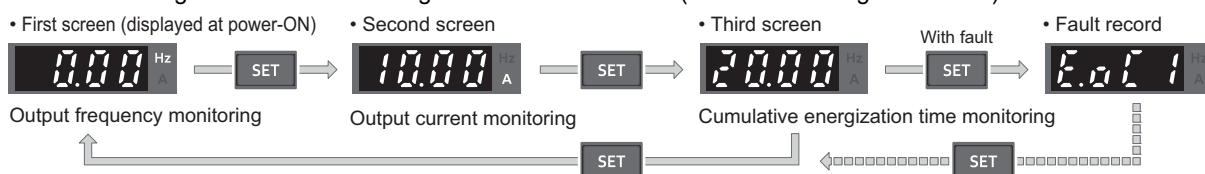

- The monitor item to be displayed is set using **Pr.774** for the first screen, **Pr.775** for the second screen, and **Pr.776** for the third screen. When **Pr.774 to Pr.776** = "9999" (initial value), the **Pr.52** setting value is used.

NOTE

- On the operation panel, the Hz LED is lit while displaying the output frequency, the Hz LED blinks when displaying the set frequency.
- When the operation panel is used, the displayed units are Hz and A only, and the others are not displayed.

◆ Displaying the set frequency during stop (Pr.52, Pr.774 to Pr.776)

- When **Pr.52** = "100", the set frequency is displayed during stop, and output frequency is displayed during running. (The Hz LED blinks during stop and is lit during operation.)

Pr.52 setting	Status	Output frequency	Output current	Output voltage	Fault monitor
0	During running/ stop	Output frequency	Output current	Output voltage	Fault monitor
100	During stop	Set frequency ^{*1}			
	During running	Output frequency			

*1 Displays the frequency that is output when the start command is ON. The value considers the maximum/minimum frequency and frequency jumps. It is different from the frequency setting displayed when **Pr.52** = "5".

- When **Pr.774 to Pr.776** = "100", the set frequency is displayed during stop, and output frequency is displayed during running. (The Hz LED blinks during stop and is lit during operation.)

Pr.774 to Pr.776 setting	Status	Output frequency	Output current	Output voltage
9999	During running/ stop	Output frequency	Output current	Output voltage
100	During stop	Set frequency ^{*1}		
	During running	Output frequency		

*1 Displays the frequency that is output when the start command is ON. The value considers the maximum/minimum frequency and frequency jumps. It is different from the frequency setting displayed when **Pr.774 to Pr.776** = "5".

NOTE

- During an error, the output frequency at error occurrence appears.
- During output shutoff by the MRS signal, the values displayed are the same as during a stop.
- During offline auto tuning, the tuning state monitor takes priority.

◆ Operation panel setting dial push display (Pr.992)

- Use **Pr.992** to select the monitor that appears when the setting dial on the operation panel is pushed.
- When **Pr.992** = "0 (initial value)", keep pressing the setting dial when in PU operation mode or External/PU combined operation mode 1 (**Pr.79 Operation mode selection** = "3") to show the presently set frequency.
- When **Pr.992** = "100", the set frequency is displayed during stop, and output frequency is displayed during running.

Pr.992 setting	Status	Monitor displayed by the setting dial push
0	During running/stop	Set frequency
100	During stop	Set frequency*1
	During running	Output frequency

*1 Displays the frequency that is output when the start command is ON. The value considers the maximum/minimum frequency and frequency jumps. It is different from the frequency setting displayed when **Pr.992** = "5".

◆ Monitoring I/O terminals on the operation panel (Pr.52, Pr.774 to Pr.776, Pr.992)

- When **Pr.52 (Pr.774 to Pr.776, Pr.992)** = "55", the I/O terminal state can be monitored on the operation panel.
- When a terminal is ON, the corresponding LED segment is ON. The center LED segments are always ON.
- On the I/O terminal monitor, the upper LEDs indicate the input terminal status, and the lower LEDs indicate the output terminal status.

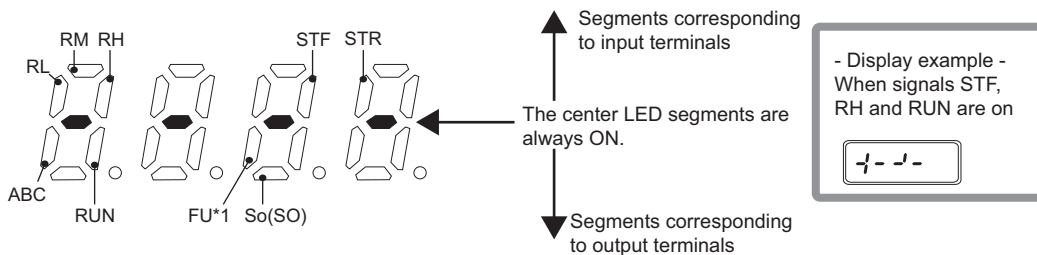

*1 The status of terminal FU is displayed regardless of the R+/FU switch (SW5) setting.

◆ Monitoring and resetting cumulative power (Pr.170, Pr.891)

- When the cumulative power is monitored (**Pr.52** = "25"), the output power monitor value is added up and is updated in 100 ms increments.
- The values are stored in EEPROM every 10 minutes. The values are also stored in EEPROM at power OFF or inverter reset.
- Increments and ranges of monitoring on the PU or via communication are as follows (when **Pr.891** = "0 or 9999").

PU			Via communication		
Range		Increment	Range		Increment
Operation panel*1	Parameter unit*2		Pr.170 = "10"	Pr.170 = "9999"	
0 to 99.99 kWh	0 to 999.99 kWh	0.01 kWh	0 to 9999 kWh	0 to 65535 kWh (initial value)	1 kWh
100.0 to 999.9 kWh	1000.0 to 9999.9 kWh	0.1 kWh			
1000 to 9999 kWh	10000 to 99999 kWh	1 kWh			

*1 Power is measured in the range of 0 to 99999.99 kWh, and displayed in 4 digits. After the watt-hour meter (cumulative power counter) reaches "99.99" (999.99 kWh), the meter displays values in 0.1 increments such as "100.0" (1000.0 kWh). Use **Pr.891** to shift the decimal point position when the monitored value becomes equal to or higher than 10000 kWh.

*2 Power is measured in the range of 0 to 99999.99 kWh, and displayed in 5 digits. After the watt-hour meter (cumulative power counter) reaches "999.99" (999.99 kWh), the meter displays values in 0.1 increments such as "1000.0" (1000.0 kWh). Use **Pr.891** to shift the decimal point position when the monitored value becomes equal to or higher than 100000 kWh.

- The decimal point position on the watt-hour meter can be shifted to left. The number of digits to be shifted is equal to the setting of **Pr.891 Cumulative power monitor digit shifted times**. For example, when **Pr.891 = "2"**, the monitored value 1278.56 kWh is displayed as 12.78 (in 100 kWh increments) on the operation panel, or displayed as 13 on a display used for monitoring via communication.
- When **Pr.891 = "0 to 4"** and the cumulative value exceeds the upper limit, the decimal point position must be shifted. When **Pr.891 = "9999"**, the meter returns to 0 and the counting starts again.
- The cumulative power can be monitored as 32-bit data via communication by setting **Pr.52 = "77 to 80"**. The maximum monitored value is 42949672 kWh in 1 kWh increments or 42949672.94 kWh in 0.01 kWh increments. **Pr.891** setting is invalid while 32-bit cumulative power is monitored. (For details on communication for 32-bit cumulative power monitor, refer to the Instruction Manual (Communication))
- Writing "0" in **Pr.170** clears the cumulative power monitor.

NOTE

- When **Pr.170** is read just after "0" has been written in **Pr.170**, the setting "9999" or "10" is displayed.

◆ Monitoring cumulative energization time (Pr.563)

- When the cumulative energization time is selected as a monitor item (**Pr.52 = "20"**), the counter of cumulative energization time since the inverter shipment is displayed.
- One hour is displayed as "0.001", and the value is counted up to "65.53".
- The EEPROM is updated every minute until the cumulative energization time reaches one hour, and then the EEPROM is updated every 10 minutes. The EEPROM is also updated at power OFF.
- When the cumulative energization time counter reaches 65535, it starts from 0 again. The number of times the cumulative energization time counter reaches 65535 can be checked with **Pr.563**.

NOTE

- The cumulative energization time does not increase if the power is turned OFF after less than an hour.

◆ Actual operation time monitoring (Pr.171, Pr.564)

- The operation time is added up every minute, and the displayed value of the actual operation time monitor (**Pr.52 = "23"**) increases by 0.001 every hour. (Time is not added up during a stop.)
- One hour is displayed as "0.001", and the value is counted up to "65.53".
- The values are stored in EEPROM every 10 minutes. The EEPROM is also updated at power OFF.
- When the cumulative energization time counter reaches 65535, it starts from 0 again. The number of times the actual operation time counter reaches 65535 can be checked with **Pr.564**.
- Writing "0" in **Pr.171** clears the actual operation time monitor.

NOTE

- The displayed value of the actual operation time monitor does not increase if the cumulative running time before power OFF is less than an hour.
- Once "0" is set in **Pr.171**, the setting of **Pr.171** is always turned to "9999" afterwards. Setting "9999" does not clear the actual operation time meter.

◆ Hiding the decimal places for the monitors (Pr.268)

- The numerical figures after a decimal point displayed on the operation panel may fluctuate during analog input, etc. The decimal places can be hidden by selecting the decimal digits with **Pr.268**.

Pr.268 setting	Description
9999 (initial value)	No function
0	For the first or second decimal places (0.1 increments or 0.01 increments) of the monitor, numbers in the first decimal place and smaller are rounded to display an integral value (1 increments). The monitor value equal to or smaller than 0.99 is displayed as 0.
1	When monitoring with the second decimal place (0.01 increments), the 0.01 decimal place is dropped and the monitor displays the first decimal place (0.1 increments). When monitoring with 1 increments, the display will not change.

NOTE

- The number of readout digits of the cumulative energization time (**Pr.52** = "20"), actual operation time (**Pr.52** = "23"), cumulative energy (**Pr.52** = "25"), and cumulative energy saving (**Pr.52** = "51") does not change.

◆ Monitor filter (Pr.1106 to Pr.1108)

- The response level (filter time constant) of the following monitor indicators can be adjusted. Increase the setting when a monitor indicator is unstable, for example.

Pr.	Monitor number	Monitor indicator name
1106	7	Motor torque
	17	Load meter
	32	Torque command
	33	Torque current command
1107	6	Motor speed
1108	18	Motor excitation current

Parameters referred to

Pr.53 Frequency / rotation speed unit switchover  page 206

Pr.55 Frequency monitoring reference, **Pr.56** Current monitoring reference, **Pr.866** Torque monitoring reference

 page 216

10.3 Monitor display selection for terminal AM

The signal (monitor item) to be output to terminal AM can be selected.

Pr.	Name	Initial value ^{*1}		Setting range	Description
		Gr.1	Gr.2		
158 M301	AM terminal function selection	1 (output frequency)		1 to 3, 5 to 14, 17, 18, 21, 24, 32, 33, 37, 50, 52, 53, 61, 62, 67, 97, 98	Select the item monitored via terminal AM.
55 M040	Frequency monitoring reference	60 Hz	50 Hz	0 to 590 Hz	Set the full-scale value when the frequency monitor value is output via terminal AM.
56 M041	Current monitoring reference	Inverter rated current		0 to 500 A	Set the full-scale value when the current monitor value is output via terminal AM.
866 M042	Torque monitoring reference	150%		0% to 400%	Set the full-scale value when the torque monitor value is output via terminal AM.

*1 Gr.1 and Gr.2 are the parameter initial value groups. (Refer to [page 46.](#))

◆ Monitor description list (Pr.158)

- Set **Pr.158 AM terminal function selection** for monitoring via terminal AM (analog voltage output).
- Refer to the following table and select the item to be monitored. (Refer to [page 209](#) for the list of monitor items.)

Monitor item	Increment and unit	Pr.158 (AM) setting	Terminal AM full-scale value	Remarks
Output frequency	0.01 Hz ^{*2}	1	Pr.55 or the value converted with the Pr.37 or Pr.81 value from Pr.55 .	
Output current ^{*1}	0.01 A	2	Pr.56	
Output voltage	0.1 V	3	100/200 V class: 400 V 400 V class: 800 V	
Frequency setting value	0.01 Hz ^{*2}	5	Pr.55 or the value converted with the Pr.37 or Pr.81 value from Pr.55 .	
Motor speed	1 r/min ^{*2}	6	Pr.55 or the value converted with the Pr.37 or Pr.81 value from Pr.55 .	
Motor torque	0.1%	7	Pr.866	
Converter output voltage ^{*1}	0.1 V	8	100/200 V class: 400 V 400 V class: 800 V	
Regenerative brake duty	0.1%	9	Brake duty decided by Pr.30, Pr.70 .	
Electronic thermal O/L relay load factor	0.1%	10	Electronic thermal O/L relay (100%)	
Output current peak value	0.01 A	11	Pr.56	
Converter output voltage peak value	0.1 V	12	100/200 V class: 400 V 400 V class: 800 V	
Input power	0.01 kW	13	Applicable motor capacity × 2 ^{*3}	
Output power ^{*1}	0.01 kW	14	Applicable motor capacity × 2 ^{*3}	
Load meter	0.1%	17	Pr.866	
Motor excitation current	0.01 A	18	Pr.56	
Reference voltage output	—	21	—	Output is 10 V.
Motor load factor	0.1%	24	200%	
Torque command	0.1%	32	Pr.866	
Torque current command	0.1%	33	Pr.866	
Heat sink temperature	1°C	37	125°C	
Energy saving effect	Increment and unit vary depending on the parameter settings.	50	Applicable motor capacity ^{*3}	For the information on the energy saving effect monitoring, refer to page 219 .

Monitor item	Increment and unit	Pr.158 (AM) setting	Terminal AM full-scale value	Remarks
PID set point	0.1%	52	100%	Refer to page 292 for the PID control.
PID measured value	0.1%	53	100%	
Motor thermal load factor	0.1%	61	Motor thermal activation level (100%)	
Inverter thermal load factor	0.1%	62	Inverter thermal activation level (100%)	
PID measured value 2	0.1%	67	100%	Refer to page 292 for the PID control.
Dancer main speed setting	0.01 Hz ^{*2}	97	Pr.55 or the value converted with the Pr.37 or Pr.81 value from Pr.55 .	For details on dancer control, refer to page 300 .
Control circuit temperature	1°C	98	100°C	

*1 The inverter regards the output current which is less than the specified current level (5% of the rated inverter current) as 0 A. Therefore, each readout of an output current and output power may show "0" if a too small-capacity motor is used as contrasted with the inverter capacity and the output current falls below the specified value.

*2 The increment varies depending on the **Pr.53** setting. (Refer to [page 206](#).)

*3 For the applicable motor capacity, refer to the inverter rated specifications in the Instruction Manual (Connection).

◆ Frequency monitor reference (Pr.55)

- Set the full-scale value when the frequency monitor value is output via terminal AM.
- Enter the full-scale value of the meter corresponding to a voltage of 10 VDC output via terminal AM. Enter the frequency value (for example, 60 Hz or 120 Hz) at full scale of the meter (10 VDC voltmeter) installed between terminals AM and 5. Output voltage is proportional to the frequency. (The maximum output voltage is 10 VDC.)

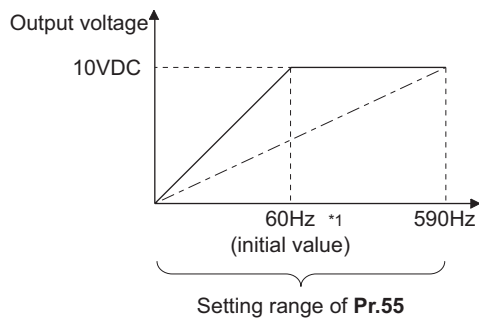

*1 Differs depending on the parameter initial value group. (60/50 Hz)

◆ Current monitor reference (Pr.56)

- Set the full-scale value when the current monitor value is output via terminal AM.
- Enter the full-scale value of the current meter corresponding to a voltage of 10 VDC output via terminal AM. Enter the current value at full scale of the meter (10 VDC voltmeter) installed between terminals AM and 5. Output voltage is proportional to the output current monitored. (The maximum output voltage is 10 VDC.)

◆ Torque monitor reference (Pr.866)

- Set the full-scale value when the torque monitor value is output via terminal AM.
- Enter the full-scale value of the torque meter corresponding to a voltage of 10 VDC output via terminal AM. Enter the torque value at full scale of the meter (10 VDC voltmeter) installed between terminals AM and 5. Output voltage is proportional to the torque monitored. (The maximum output voltage is 10 VDC.)

10.4 Adjustment of terminal AM

By using the operation panel or the parameter unit, you can adjust (calibrate) terminal AM to full-scale deflection.

Pr.	Name	Initial value	Setting range	Description
C1 (901) M320^{*1}	AM terminal calibration	—	—	Calibrates the scale of the analog meter connected to terminal AM.
1200 M390	AM output offset calibration	4499	4000 to 5000	Calibrates the scale of the meter when the analog output is 0.

*1 On the LCD operation panel or the parameter unit used as the command source, the parameter number in parentheses appears instead of that starting with the letter C.

◆ Terminal AM calibration (C1 (Pr.901))

- Terminal AM is initially set to provide a 10 VDC output in the full-scale state of the corresponding monitor item. The calibration parameter **C1 (Pr.901) AM terminal calibration** allows the output voltage ratio (gains) to be adjusted according to the meter scale. Note that the maximum output voltage is 10 VDC.

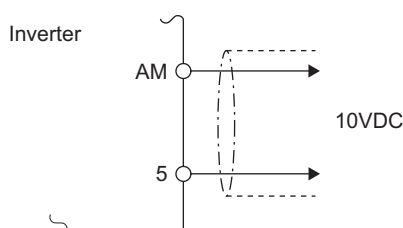

- Calibrate the output via terminal AM in the following procedure.
 - Connect a 0-10 VDC indicator (frequency meter) across terminal AM and terminal 5 on the inverter. (Note the polarity. Terminal AM is positive.)
 - Set a monitor item in **Pr.158 AM terminal function selection**. (Refer to [page 216](#).)
When the output frequency or inverter output current is selected on the monitor, set the output frequency or current value at which the output signal is 10 V, using **Pr.55** or **Pr.56** beforehand.
 - If the meter needle does not point to maximum even at maximum output, calibrate it with **C1 (Pr.901)**.

NOTE

- When outputting an item such as the output current, which cannot reach a 100% value easily by operation, set **Pr.158** to "21" (reference voltage output) and calibrate. A voltage of 10 VDC is output via terminal AM.

◆ Calibration when 0 V is output via terminal AM (Pr.1200)

- When 0 is output via terminal AM, use **Pr.1200 AM output offset calibration** to calibrate the meter. If the meter needle does not point to 0 while 0 is output via terminal AM, set a value in **Pr.1200** so that the needle points to 0.
- Set a larger value in **Pr.1200** when the needle points a minus output voltage while the 0 is output via terminal AM. Set a smaller value in **Pr.1200** when the needle points a plus output voltage while the 0 is output via terminal AM.

Parameters referred to

Pr.55 Frequency monitoring reference [page 216](#)

Pr.56 Current monitoring reference [page 216](#)

Pr.158 AM terminal function selection [page 216](#)

10.5 Energy saving monitoring

From the power consumption estimated value during commercial power supply operation, the energy saving effect by use of the inverter can be monitored and output.

Pr.	Name	Initial value	Setting range	Description
52 M100	Operation panel main monitor selection	0 (output frequency)	Refer to page 208 .	50: Energy saving effect 51: Cumulative saved energy
774 M101	Operation panel monitor selection 1	9999		
775 M102	Operation panel monitor selection 2			
776 M103	Operation panel monitor selection 3			
992 M104	Operation panel setting dial push monitor selection	0 (set frequency)		
158 M301	AM terminal function selection	1 (output frequency)	Refer to page 216 .	50: Energy saving effect
891 M023	Cumulative power monitor digit shifted times	9999	0 to 4	Set the number of times to move the digit of cumulative energy monitored value. The readout peaks out at the upper limit of readout.
			9999	The function of moving the decimal point is not available. The readout is reset to 0 when it exceeds the upper limit.
892 M200	Load factor	100%	30% to 150%	Set the load factor for the commercial power supply operation. The setting is used for calculation of the estimated power consumption during commercial power supply operation by being multiplied by the power consumption rate (page 224).
893 M201	Energy saving monitor reference (motor capacity)	Applicable motor capacity	0.1 to 18.5 kW	Set the motor capacity (pump capacity). Setting this parameter is required for calculating the rate of saved power, the rate of average energy saving, and the commercial power.
894 M202	Control selection during commercial power-supply operation	0	0	Discharge damper control (fan)
			1	Inlet damper control (fan)
			2	Valve control (pump)
			3	Commercial power supply drive (fixed value)
895 M203	Power saving rate reference value	9999	0	Consider the commercial power as 100%.
			1	Consider the power set in Pr.893 as 100%
			9999	No function
896 M204	Power unit cost / CO ₂ emission coefficient	9999	0 to 500	Set the power unit cost / CO ₂ emission coefficient.
			9999	No function
897 M205	Energy saving monitor average time	9999	0	The time period for averaging is 30 minutes.
			1 to 1000 h	Set the number of hours for averaging.
			9999	No function
898 M206	Energy saving cumulative monitor clear	9999	0	Clear the cumulative monitor value
			1	Hold the cumulative monitor value
			10	Continue accumulation (upper limit communication data is 9999)
			9999	Continue accumulation (upper limit communication data is 65535)
899 M207	Operation time rate (estimated value)	9999	0% to 100%	Setting this parameter is required for calculating the annual energy saving. Set an annual operating rate (considering a 24-hours-a-day and 365-days-a-year operation as 100%).
			9999	No function

◆ Energy saving monitoring list

- The items in the energy saving effect monitoring (items which can be monitored when "50" is set in **Pr.52, Pr.158, Pr.774 to Pr.776, and Pr.992**) are listed below.

(The items which can be monitored via terminal AM (**Pr.158** setting) are limited to [1 Power saving] and [3 Average power saving].)

	Energy saving monitor item	Description and formula	Unit and increment	Parameter setting			
				Pr.895	Pr.896	Pr.897	Pr.899
1	Power saving	Difference between the estimated value of the required power during commercial power supply operation and the input power calculated with the inverter. [Power required for commercial power supply operation] - [Input power]	0.01 kW	9999	—	9999	—
2	Power saving rate	Rate of the power saving expressed as a percentage with respect to the power for the commercial power supply operation. $\frac{[1 \text{ Power saving}]}{\text{Power during commercial power supply operation}} \times 100$	0.1%	0			
		Rate of the power saving expressed as a percentage with respect to the Pr.893 setting. $\frac{[1 \text{ Power saving}]}{\text{Pr.893}} \times 100$		1			
3	Average power saving	Average hourly energy saving during a monitoring time (set in Pr.897). $\frac{\sum ([1 \text{ Power saving}] \times \Delta t)}{\text{Pr.897}}$	0.01 kWh	9999	9999	0 to 1000 h	
4	Average power saving rate	Rate of average hourly power saving expressed as a percentage with respect to the power for the commercial power supply operation. $\frac{\sum ([2 \text{ Power saving rate}] \times \Delta t)}{\text{Pr.897}} \times 100$	0.1%	0			
		Rate of average hourly power saving expressed as a percentage with respect to the Pr.893 setting. $\frac{[3 \text{ Average power saving}]}{\text{Pr.893}} \times 100$		1			
5	Average power cost savings / average CO ₂ emission reduction	Monetary value or CO ₂ emission reduction converted from the average power saving rate. [3 Average power saving] × Pr.896 setting	0.01/0.1	—	0 to 500		

- The items in the cumulative energy saving monitoring (items which can be monitored when "51" is set in **Pr.52, Pr.774 to Pr.776, and Pr.992**) are listed below.

(The digit of the cumulative energy saving monitored value can be moved to the right according to the setting of **Pr.891 Cumulative power monitor digit shifted times.**)

	Energy saving monitor item	Description and formula	Unit and increment	Parameter setting			
				Pr.895	Pr.896	Pr.897	Pr.899
6	Energy saving amount	Saved power multiplied by the number of operating hours. $\Sigma ([1 \text{ Power saving}] \times \Delta t)$	0.01 kWh ^{*1*2}	—	9999	—	9999
7	Energy cost savings / CO ₂ emission reduction	Monetary value or CO ₂ emission reduction converted from the energy saving amount. [6 Energy saving amount] × Pr.896 setting	0.01 ^{*1}	—	0 to 500		
8	Annual energy saving amount	Estimated annual energy saving. $\frac{[6 \text{ Power saving amount}]}{\text{Operation time during power saving accumulation}} \times 24 \times 365 \times \frac{\text{Pr.899}}{100}$	0.01 kWh ^{*1*2}	—	9999		0% to 100%
9	Annual energy cost savings / annual CO ₂ emission reduction	Monetary value or CO ₂ emission reduction converted from the annual energy saving amount. [8 Annual energy saving amount] × Pr.896 setting	0.01 ^{*1}	—	0 to 500		

*1 For monitoring via communication, the increments are 1 in no units. For example, a value "10.00 kWh" is converted into "10" for communication data.

*2 On the LCD operation panel or the parameter unit, a readout is displayed in units of kilowatt-hours (kW).

NOTE

- The operation panel have a 4-digit display. This means, for example, that a monitored value up to "99.99" is displayed in 0.01 increments and a monitor value of 100 or more is displayed in 0.1 increments as "100.0". The maximum monitored value displayed is "9999".
- The parameter unit have a 5-digit display. This means, for example, that a monitored value up to 999.99 is displayed in 0.01 increments and a monitor value of 1000 or more is displayed in 0.1 increments as "1000.0". The maximum monitored value displayed is "99999".
- The maximum monitored value via communication is 65535 when **Pr.898 Energy saving cumulative monitor clear = "9999"**. The maximum monitored value on monitoring in 0.01 increments is "655.35", and that on monitoring in 0.1 increments is "6553.5".

◆ Power saving real-time monitoring ([1 Power saving], [2 Power saving rate])

- During [1 Power saving] monitoring, an energy saving effect (power difference) of using the inverter as compared to the commercial power supply operation is calculated and displayed on the main monitor.
- In the following cases, the monitored value of [1 Power saving] is "0".
The result of calculating the saved power is negative value.
DC injection brake works.
The motor is not connected with the inverter (monitored value of output current is 0 A).
- On [2 Power saving rate] monitoring, the rate of the saved power considering the consumed power (estimate) during the power supply operation as 100% is displayed when Pr.895 Power saving rate reference value is set to "0". When Pr.895 is set to "1", the rate of the saved power with respect to the setting of Pr.893 Energy saving monitor reference (motor capacity) that is referenced as 100% is displayed.

◆ Average power saving monitoring ([3 Average power saving], [4 Average power saving rate], [5 Average power cost savings / average CO₂ emission reduction])

- The average power saving monitors are displayed by setting a value other than 9999 in Pr.897 Energy saving monitor average time.
- On [3 Average power saving] monitoring, the average hourly energy saving every preset time period is displayed.
- When the setting of Pr.897 is changed, when the inverter is powered ON, or when the inverter is reset, the averaging is restarted. The Energy saving average value updated timing (Y92) signal is inverted every time the averaging is restarted.

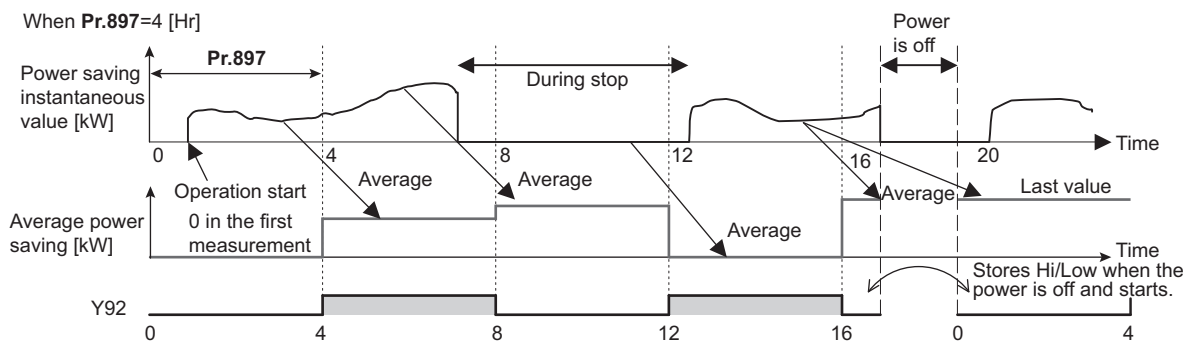

- On [4 Average power saving rate] monitoring, the average hourly monitored value of [2 Power saving rate] is displayed when Pr.895 Power saving rate reference value is set to "0 or 1".
- On [5 Average power cost savings / average CO₂ emission reduction] monitoring, a momentary value or CO₂ emission reduction of the average hourly energy saving ([3 Average power saving] × Pr.896 setting) is displayed when the unit price (power cost per kilowatt hour) or CO₂ emission amount (CO₂ emission coefficient) is set in Pr.896 Power unit cost / CO₂ emission coefficient.
- If the national average CO₂ emission coefficient for general power transmission and distribution business operators is 0.000434 (t-CO₂/kWh), set Pr.896 to 0.43, which is obtained by calculating 0.000434×10^3 . At this time, the average CO₂ emission reduction amount is displayed in units of kg-CO₂.
- The unit of the CO₂ emission coefficient may differ depending on the country where the inverter is used (such as t, lb, and g). Make adjustments according to the setting range of Pr.896.

◆ **Cumulative energy saving monitoring ([6 Energy saving amount], [7 Energy cost savings / CO₂ emission reduction], [8 Annual energy saving amount], [9 Annual energy cost savings / annual CO₂ emission reduction])**

- The decimal point position of the cumulative energy saving monitored value can be shifted to left. The number of digits to be shifted is equal to the setting of **Pr.891 Cumulative power monitor digit shifted times**. For example, when **Pr.891 = "2"**, the monitored value 1278.56 kWh is displayed as 12.78 (in 100 kWh increments) on the operation panel, or displayed as 13 on a display used for monitoring via communication. When **Pr.891 = "0 to 4"** and the cumulative value exceeds the upper limit, the decimal point position must be shifted. When **Pr.891 = "9999"**, the meter returns to 0 and the counting starts again. The readout of other items in the cumulative energy saving monitoring peaks out at the upper limit of readout.
- With the monitored value of **[6 Energy saving amount]**, a cumulative energy saving during a desired time period can be measured. Follow this procedure.

- 1.** Set "10" or "9999" in **Pr.898 Energy saving cumulative monitor clear**.
- 2.** Change the setting of **Pr.898** to "0" when you want to start measuring the energy saving. The cumulative value is cleared and the cumulative energy saving meter restarts.
- 3.** Change the setting of **Pr.898** to "1" when you want to stop measuring the energy saving. The meter stops and the cumulative value is fixed.

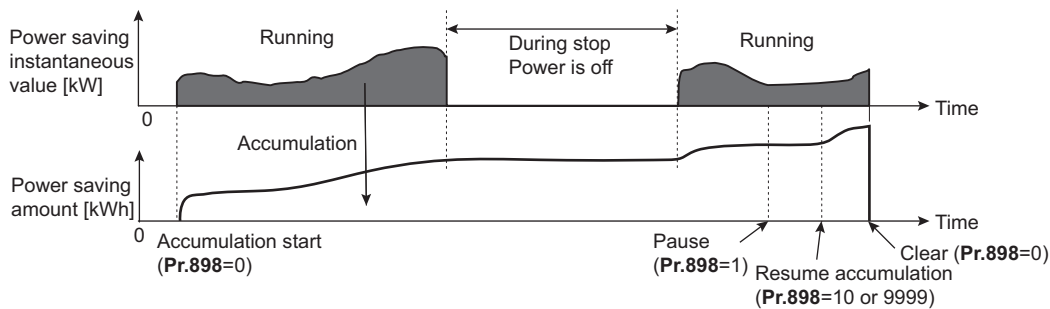

NOTE

- The cumulative value of energy saving is refreshed every hour. This means that the last cumulative value is displayed at a restart of the inverter and the cumulative meter restarts if the time elapsed between turning OFF and re-turning ON of the inverter is shorter than an hour. (In some cases, the cumulative energy value may decrease.)

◆ Estimated input power for the commercial power supply operation (Pr.892, Pr.893, Pr.894)

- Select the pattern of the commercial power supply operation from among four patterns (discharge damper control (fan), suction damper control (fan), valve control (pump) and commercial power drive), and set it in **Pr.894 Control selection during commercial power-supply operation**.
- Set the motor capacity (pump capacity) in **Pr.893 Energy saving monitor reference (motor capacity)**.
- Refer to the following graph to find the rate of power consumption (%) during commercial power supply operation based on the selected pattern and the rate of motor rotations per minute with respect to the rated speed (the result of dividing the present output frequency by **Pr.3 Base frequency** setting).

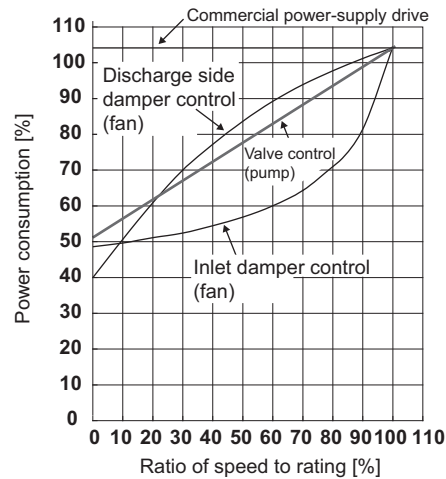

- The estimated input power (kW) for the commercial power supply operation is calculated from the motor capacity set in **Pr.893**, the setting of **Pr.892 Load factor**, and the rate of power consumption using the following formula.

$$\text{Estimated consumed power during commercial power supply operation (kW)} = \text{Pr.893 (kW)} \times \frac{\text{Consumed power (\%)}}{100} \times \frac{\text{Pr.892 (\%)}}{100}$$

NOTE

- If the output frequency rises to the setting of **Pr.3 Base frequency** or higher, it stays at a constant value because the rotations per minute cannot rise higher than the power supply frequency during commercial power supply operation.

◆ Annual energy saving and its monetary value, and annual CO₂ emission reduction (Pr.896, Pr.899)

- When the operation time rate (ratio of the time period in year when the inverter drives the motor) [%] is set in **Pr.899**, the annual energy saving effect can be estimated.
- When the inverter is operated in specific patterns, the estimate annual energy saving can be calculated by measuring the energy saving in a certain period.
- Refer to the following procedure to set the operation time rate.

1. Estimate the average operation time per day (h/day).
2. Calculate the operation days per year (days/year) using the following formula: Average operation days per month × 12 (months).
3. Calculate the annual operation time (h/year) from values determined in Step 1 and Step 2, using the following formula.

$$\text{Annual operation time (h/year)} = \text{average time (h/day)} \times \text{number of operation days (days/year)}$$

4. Calculate the operation time rate using the following formula, and set it in **Pr.899**.

$$\text{Operation time rate (\%)} = \frac{\text{Annual operation time (h/year)}}{24 \text{ (h/day)} \times 365 \text{ (days/year)}} \times 100(\%)$$

NOTE

- Setting example for operation time rate: In the case where the average operation time per day is about 21 hours and the average operation days per month is 16 days.

$$\text{Annual operation time} = 21 \text{ (h/day)} \times 16 \text{ (days/month)} \times 12 \text{ months} = \underline{4032 \text{ (h/year)}}$$

$$\text{Operation time rate (\%)} = \frac{4032 \text{ (h/year)}}{24 \text{ (h/day)} \times 365 \text{ (days/year)}} \times 100(\%) = \underline{46.03\%}$$

Therefore, set 46.03% in **Pr.899**.

- Calculate the annual energy saving from **Pr.899 Operation time rate (estimated value)** and the average power saving monitor value.

$$\text{Annual power saving amount (kWh/year)} = \text{With Pr.898 = 10 or 9999, average power saving (kW) during cumulative period} \times 24\text{h} \times 365 \text{ days} \times \frac{\text{Pr.899}}{100}$$

- When the power cost or CO₂ emission amount per hour is set in **Pr.896 Power unit cost / CO₂ emission coefficient**, the annual energy cost savings or annual CO₂ emission reduction can be monitored.

The annual energy cost savings or annual CO₂ emission reduction is determined by calculation using the following formula.

$$\text{Annual power cost saving or annual CO}_2 \text{ emission reduction} = \text{annual power saving amount (kWh/year)} \times \text{Pr.896}$$

- If the national average CO₂ emission coefficient for general power transmission and distribution business operators is 0.000434 (t-CO₂/kWh), set **Pr.896** to 0.43, which is obtained by calculating 0.000434×10^3 . At this time, the annual CO₂ emission reduction amount is displayed in units of kg-CO₂/year.
- The unit of the CO₂ emission coefficient may differ depending on the country where the inverter is used (such as t, lb, and g). Make adjustments according to the setting range of **Pr.896**.

NOTE

- During regenerative driving, substitute the output power during the commercial power supply operation for the saved power (therefore, input power = 0).

Parameters referred to

Pr.3 Base frequency  page 329

Pr.52 Operation panel main monitor selection  page 208

Pr.158 AM terminal function selection  page 216

10.6 Output terminal function selection

Use the following parameters to change the functions of the open collector output terminals and relay output terminals.

Pr.	Name		Initial value	Signal name	Setting range
190 M400	RUN terminal function selection	For open collector output terminal	0	RUN (Inverter running)	0, 1, 3, 4, 7, 8, 11 to 16, 18, 19, 25, 26, 33, 34, 40, 41, 44 to 48, 57, 64 to 66, 70, 79 to 81, 90 to 93, 95, 96, 98, 99, 100, 101, 103, 104, 107, 108, 111 to 116, 125, 126, 133, 134, 140, 141, 144 to 148, 157, 164 to 166, 170, 179 to 181, 190 to 193, 195, 196, 198, 199, 206, 207, 211 to 213, 306, 307, 311 to 313, 9999
191 M404	FU terminal function selection		4	FU (Output frequency detection)	
192 M405	ABC terminal function selection	For relay output terminal	99	ALM (Fault)	0, 1, 3, 4, 7, 8, 11 to 16, 18, 19, 25, 26, 33, 34, 40, 41, 44 to 48, 57, 64 to 66, 70, 79 to 81, 90, 91, 95, 96, 98, 99, 100, 101, 103, 104, 107, 108, 111 to 116, 125, 126, 133, 134, 140, 141, 144 to 148, 157, 164 to 166, 170, 179 to 181, 190, 191, 195, 196, 198, 199, 206, 207, 211 to 213, 306, 307, 311 to 313, 9999
193 M451	NET Y1 output selection	Virtual output terminal for communication operation	9999	No function	0, 1, 3, 4, 7, 8, 11 to 16, 18, 19, 25, 26, 33, 34, 40, 41, 44 to 48, 57, 64 to 66, 70, 79 to 81, 90 to 93, 95, 98, 99, 100, 101, 103, 104, 107, 108, 111 to 116, 125, 126, 133, 134, 140, 141, 144 to 148, 157, 164 to 166, 170, 179 to 181, 190 to 193, 195, 198, 199, 206, 207, 211 to 213, 306, 307, 311 to 313, 9999
194 M452	NET Y2 output selection				
195 M453	NET Y3 output selection				
196 M454	NET Y4 output selection				

Pr.	Name	Initial value	Setting range	Description
289 M431	Inverter output terminal filter	9999	5 to 50 ms	Set the time delay for the output terminal response.
			9999	No filtering of the output terminal.

◆ Output terminal function assignment

- Signals can be output from the inverter by using physical terminals or via communication,
- Use parameters to assign functions to output terminals. Check the terminal available for each parameter.

Pr.	Terminal name	External output terminal (physical terminal)	Output via communication*1
190	RUN	○	○
191	R+/FU	○*2	○
192	A,B,C	○	○
193	NET Y1	—	○
194	NET Y2	—	○
195	NET Y3	—	○
196	NET Y4	—	○

○: Assignment/output available, —: Assignment/output unavailable (no function)

*1 The communication protocol affects which terminal can be used. For details, refer to the Instruction Manual (Communication).

*2 When the R+/FU switch (SW5) is set to the upper position (FU) (initial status), the assigned function is enabled. Assignment is not available when the RS-485 terminal is used for RS-485 communication. For details, refer to the Instruction Manual (Connection) and the Instruction Manual (Communication).

◆ Output signal list

- A function listed below can be set to each output terminal.
- Refer to the following table and set the parameters. (0 to 99, 200 to 299: Positive logic, 100 to 199, 300 to 399: Negative logic)

Setting		Signal name	Function	Operation	Related parameter	Refer to page
Positive logic	Negative logic					
0	100	RUN	Inverter running	Output during operation when the inverter output frequency reaches Pr.13 Starting frequency or higher.	—	230
1	101	SU	Up to frequency ^{*1}	Output when the output frequency reaches the set frequency.	Pr.41	234
3	103	OL	Overload warning	Output while the stall prevention function works.	Pr.22, Pr.23, Pr.66, Pr.154	195
4	104	FU	Output frequency detection	Output when the output frequency reaches the frequency set in Pr.42 (Pr.43 during reverse rotation) or higher.	Pr.42, Pr.43	234
7	107	RBP	Regenerative brake prealarm	Output when the regenerative brake duty reaches 85% of the setting of Pr.70 .	Pr.70	340
8	108	THP	Electronic thermal O/L relay pre-alarm	Output when the cumulative electronic thermal O/L relay value reaches 85% of the trip level. (The electronic thermal O/L relay function (E.THT/E.THM) is activated when the value reaches 100%.)	Pr.9	166
11	111	RY	Inverter operation ready	Output when the reset process is completed after powering ON the inverter or when the inverter is ready to start operation with the start signal ON or during operation.	—	230
12	112	Y12	Output current detection	Output when the output current is higher than the Pr.150 setting for the time set in Pr.151 or longer.	Pr.150, Pr.151	237
13	113	Y13	Zero current detection	Output when the output current is lower than the Pr.152 setting for the time set in Pr.153 or longer.	Pr.152, Pr.153	237
14	114	FDN	PID lower limit	Output when the input value is lower than the lower limit set for the PID control operation.	Pr.127 to Pr.134, Pr.575 to Pr.577	283
15	115	FUP	PID upper limit	Output when the input value is higher than the upper limit set for the PID control operation.		
16	116	RL	PID forward/reverse rotation output	Output during forward rotation operation in the PID control operation.		
18	—	MC2	Electronic bypass MC2	Used to enable the electronic bypass during emergency drive operation.	Pr.136, Pr.139	182
19	—	MC3	Electronic bypass MC3			
25	125	FAN	Fan fault output	Output when a fan fault occurs.	Pr.244	174
26	126	FIN	Heat sink overheat pre-alarm	Output when the heat sink temperature rises to 85% of temperature at which the protective function of the Heat sink overheat is activated.	—	Instruction Manual (Maintenance)
33	133	RY2	Operation ready 2	Output while pre-excitation is enabled or during normal operation under PM sensorless vector control.	—	230
34	134	LS	Low speed detection	Output when the output frequency drops to the Pr.865 setting or lower.	Pr.865	234
40	140	Y40	Trace status	Output during trace operation.	Pr.1020, Pr.1022 to Pr.1047	320
41	141	FB	Speed detection	Output when the actual motor rotations per minute (estimate) reaches the setting of Pr.42 .	Pr.42	234

Setting		Signal name	Function	Operation	Related parameter	Refer to page
Positive logic	Negative logic					
44	144	RUN2	Inverter running 2	Output while the Forward rotation command signal or Reverse rotation command signal is ON. Output during deceleration even while the Forward rotation command signal or Reverse rotation command signal is OFF. (The signal is not output while pre-excitation is enabled (the LX signal is ON).)	—	230
45	145	RUN3	Inverter running and start command ON	Output while the inverter is running or while the start command signal is ON.	—	230
46	146	Y46	During deceleration at occurrence of power failure	Output when the power-failure deceleration function is activated. (The signal output is retained until the function stops.)	Pr.261	318
47	147	PID	During PID control activated	Output during the PID control operation.	Pr.127 to Pr.134, Pr.575 to Pr.577	283
48	148	Y48	PID deviation limit	Output when the absolute deviation value exceeds the limit value.	Pr.127 to Pr.134, Pr.553, Pr.554	283
57	157	PM	During PM sensorless vector control	Output while the operation is performed under PM sensorless vector control.	Pr.71, Pr.80, Pr.998	77
64	164	Y64	During retry	Output during retry operation.	Pr.65 to Pr.69	179
65	165	Y65	Emergency drive in operation	Output during emergency drive operation.	Pr.514, Pr.515, Pr.523, Pr.524, Pr.1013	182
66	166	ALM3	Fault output during emergency drive	Output when a fault occurs during emergency drive operation.		
70	170	SLEEP	PID output interruption	Output while PID output suspension function is activated.	Pr.127 to Pr.134, Pr.575 to Pr.577	283
79	179	Y79	Pulse train output of output power	Output in pulses every time the cumulative value of energy output from the inverter reaches the Pr.799 setting.	Pr.799	241
80	180	SAFE	Safety monitor output	Output while the safety stop function is activated.	—	Instruction Manual (Functional Safety)
81	181	SAFE2	Safety monitor output 2	Output when no internal safety circuit failure exists.		
90	190	Y90	Life alarm	Output when the life check function detects the part approaching the end of its life.	Pr.255 to Pr.259, Pr.506, Pr.507, Pr.509	122
91	191	Y91	Fault output 3 (power-OFF signal)	Output when the Fault occurs due to an inverter circuit fault or connection fault.	—	233
92	192	Y92	Energy saving average value updated timing	Switches between ON and OFF every time the average energy saving is updated during the energy saving monitoring. This signal cannot be assigned to any of the relay output terminal (Pr.192).	Pr.52, Pr.158, Pr.891 to Pr.899	219
93	193	Y93	Current average monitor	Output in pulses for transmission of the average current value and the maintenance timer value. This signal cannot be assigned to any of the relay output terminal (Pr.192).	Pr.555 to Pr.557	127
95	195	Y95	Maintenance timer	Output when the value of Pr.503 reaches the Pr.504 setting or higher.	Pr.503, Pr.504	126
96	196	REM	Remote output	Output via a terminal by setting a proper number in a relative parameter. The value cannot be set in Pr.193 to Pr.196.	Pr.495, Pr.496	239
98	198	LF	Alarm	Output when an Alarm fault (fan fault or a communication error) occurs.	Pr.121, Pr.244	Instruction Manual (Communication), page 174

Setting		Signal name	Function	Operation	Related parameter	Refer to page
Positive logic	Negative logic					
99	199	ALM	Fault	Output when the inverter's protective function is activated to stop the power output (when the Fault occurs). The signal output stops when the inverter reset starts.	—	232
206	306	Y206	Cooling fan operation command	Output when the cooling fan operation is commanded.	Pr.244	174
207	307	Y207	Control circuit temperature	Output when the temperature of the control circuit board reaches the detection level or higher.	Pr.663	242
211	311	LUP	Upper limit warning detection	Output when the load fault upper limit warning is detected.	Pr.1480 to Pr.1492	200
212	312	LDN	Lower limit warning detection	Output when the load fault lower limit warning is detected.		
213	313	Y213	During load characteristics measurement	Output during measurement of the load characteristics.		
9999		—	No function	—	—	—

*1 Note that changing the frequency setting with an analog signal or the setting dial on the operation panel may cause the turning ON and OFF of Up to frequency (SU) signal depending on its changing speed and the timing of the speed change determined by the acceleration/deceleration time setting. (The signal state changing does not occur when the acceleration/deceleration time is set to 0 second.)

NOTE

- One function can be assigned to more than one terminal.
- The function works during the terminal conducts when the parameter setting is any of "0 to 99, 200 to 299", and the function works during the terminal does not conduct when the setting is "100 to 199, 300 to 399".
- Changing the terminal assignment using **Pr.190 to Pr.196 (Output terminal function selection)** may affect the other functions. Set parameters after confirming the function of each terminal.
- Do not assign the signal to terminals A, B, and C which frequently changes its state between ON and OFF. Doing so may shorten the life of the relay contact.

◆ Adjusting the output terminal response level (Pr.289)

- The responsivity of the output terminals can be delayed in a range between 5 to 50 ms. (The following is the operation example of the RUN signal.)

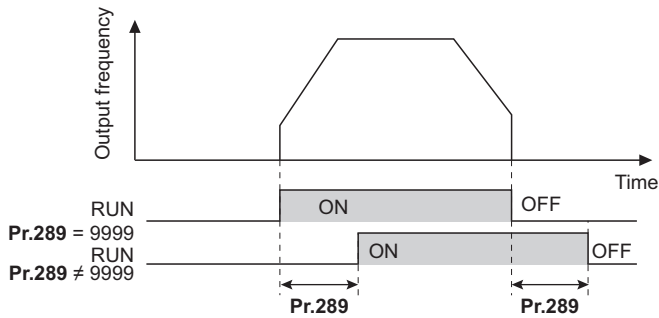

NOTE

- When **Pr.157 OL signal output timer** is set for the Overload warning (OL) signal output, the OL signal is output after the time period calculated by adding the **Pr.289** setting to the **Pr.157** setting elapsed.

◆ Inverter operation ready signals (RY, RY2 signals) and inverter running signals (RUN, RUN2, RUN3 signals)

■ Operation under V/F control and Advanced magnetic flux vector control

- When the inverter is ready for operation, the Inverter operation ready (RY) signal turns ON (and stays ON during operation).
- When the inverter output frequency reaches the setting of **Pr.13 Starting frequency** or higher, the inverter running signals (RUN, RUN2 signals) turn ON. The signal is OFF during an inverter stop, during the DC injection brake operation, or during tuning at start-up.
- The Inverter running and start command ON (RUN3) signal is ON while the inverter is running or while the start command signal is ON. (When the start command signal is ON, the RUN3 signal is ON even while the inverter's protective function is activated or while the MRS signal is ON.) The RUN3 signal is ON even during the DC injection brake operation, and the signal is OFF when the inverter stops.

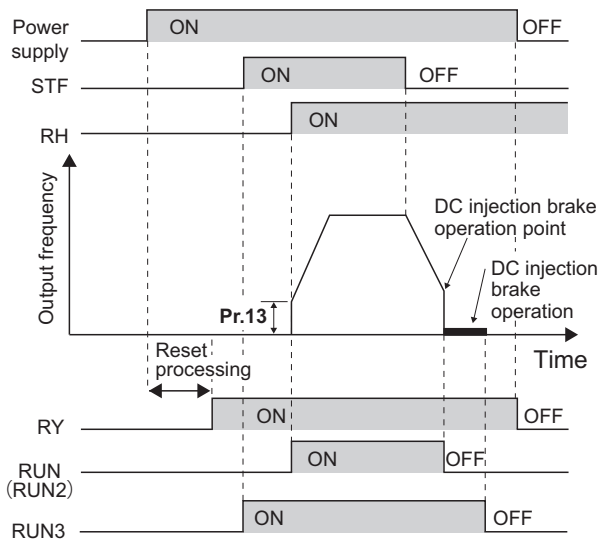

- The ON/OFF state of each signal according to the inverter operating status is shown in the matrix below.

Output signal	Start signal OFF (inverter stopped)	Start signal ON (inverter stopped)	Start signal ON (inverter running)	During DC injection brake operation	Inverter output shutoff ²		Automatic restart after instantaneous power failure		
							During coasting		Inverter running after restart
					Start signal ON	Start signal OFF	Start signal ON	Start signal OFF	
RY ^{*3}	ON	ON	ON	ON	OFF		ON ^{*1}		ON
RY2	OFF	OFF	OFF	OFF	OFF		OFF		OFF
RUN	OFF	OFF	ON	OFF	OFF		OFF		ON
RUN2	OFF	OFF	ON	OFF	OFF		OFF		ON
RUN3	OFF	ON	ON	ON	ON	OFF	ON	OFF	ON

*1 The signal is OFF during power failure or undervoltage.

*2 This means the state during a fault occurrence or while the MRS signal is ON, etc.

*3 The signal is OFF while power is not supplied to the main circuit.

■ Operation under PM sensorless vector control

- When the inverter is ready for operation, the Inverter operation ready (RY) signal turns ON (and stays ON during operation).
- When the inverter output frequency reaches the setting of **Pr.13 Starting frequency** or higher, the Inverter running (RUN) signal turns ON. The signal is OFF during an inverter stop, during the DC injection brake operation, during tuning at start-up, or during pre-excitation.
- The Inverter running 2 (RUN2) signal is ON while the inverter is running or while the start command signal is ON. (When the inverter's protective function is activated or the MRS signal is ON, the RUN2 signal turns OFF.)
- The Inverter running and start command ON (RUN3) signal is ON while the inverter is running or while the start command signal is ON.
- The Operation ready 2 (RY2) signal turns ON when the pre-excitation starts. The signal is ON during pre-excitation even while the inverter is stopped. The signal is OFF during the inverter output shutoff.

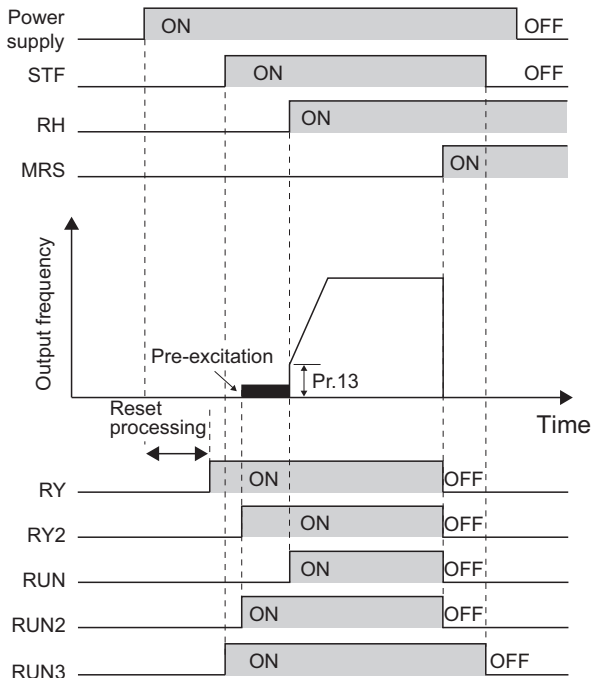

NOTE

- When pre-excitation works with the Pre-excitation (LX) signal ON, the RY2 signal turns ON after 100 ms from the time the LX signal turns ON.

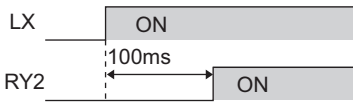

- The ON/OFF state of each signal according to the inverter operating status is shown in the matrix below.

Output signal	Start signal OFF (inverter stopped)	Start signal ON (inverter stopped)	Start signal ON (during pre-excitation) ^{*1}	Start signal ON (inverter running)	LX signal ON (during pre-excitation)	During DC injection brake operation		Inverter output shutoff ^{*4}		Automatic restart after instantaneous power failure		
						Start signal ON	Start signal OFF	Start signal ON	Start signal OFF	During coasting		Inverter running after restart
										Start signal ON	Start signal OFF	
RY ^{*5}	ON	ON	ON	ON	ON	ON		OFF		ON ^{*2}		ON
RY2	OFF	OFF	ON	ON	ON ^{*3}	ON		OFF		OFF		ON
RUN	OFF	OFF	OFF	ON	OFF	OFF		OFF		OFF		ON
RUN2	OFF	OFF	ON	ON	OFF	ON	OFF	OFF		OFF		ON
RUN3	OFF	ON	ON	ON	ON	ON		ON	OFF	ON	OFF	ON

- ^{*1} This means the state that the start command is ON, the frequency command is 0 Hz, and the LX signal is ON.
- ^{*2} The signal is OFF during power failure or undervoltage.
- ^{*3} The signal turns ON after 100 ms from the time the LX signal turns ON.
- ^{*4} This means the state during a fault occurrence or while the MRS signal is ON, etc.
- ^{*5} The signal is OFF while power is not supplied to the main circuit.

- To use the RY, RY2, RUN, RUN2, or RUN3 signal, set the corresponding number in the following table in any parameter from Pr.190 to Pr.196 (Output terminal function selection) to assign the function.

Output signal	Pr.190 to Pr.196 settings	
	Positive logic	Negative logic
RY	11	111
RY2	33	133
RUN	0	100
RUN2	44	144
RUN3	45	145

NOTE

- The RUN signal (positive logic) is initially assigned to the terminal RUN.

◆ Fault output (ALM) signal

- The fault signal (ALM signal) is output when an inverter protective function is activated.
- The ALM signal is assigned to the terminals A, B, and C in the initial status.

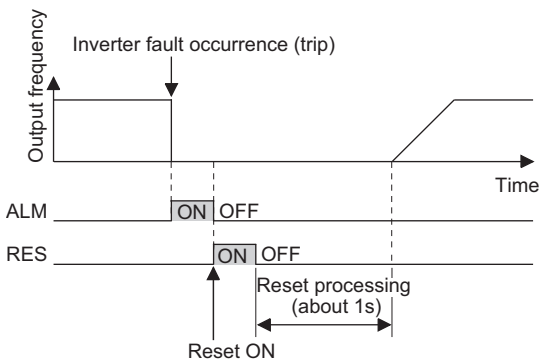

NOTE

- For details of the inverter faults, refer to the Instruction Manual (Maintenance).

◆ Input power shutoff like magnetic contactor (Y91 signal)

- The Fault output 3 (Y91) signal is output when a fault originating in the inverter circuit or a connection fault occurs.
- To use the Y91 signal, set "91" (positive logic) or "191" (negative logic) in any parameter from **Pr.190 to Pr.196 (Output terminal function selection)** to assign the function to an output terminal.
- The following is the list of faults that output the Y91 signal. (For details on faults, refer to the Instruction Manual (Maintenance).)

Fault type
Inrush current limit circuit fault (E.IOH)
CPU fault (E.CPU)
CPU fault (E.6)
CPU fault (E.7)
Parameter storage device fault (control circuit board) (E.PE)
Parameter storage device fault (main circuit board) (E.PE2)
Internal storage device fault (E.PE6)
Output side earth (ground) fault overcurrent (E.GF)
Output phase loss (E.LF)
Brake transistor alarm detection (E.BE)
Internal circuit fault (E.13)

Parameters referred to

Pr.13 Starting frequency  [page 139](#), [page 141](#)

10.7 Output frequency detection

If the inverter output frequency which reaches a specific value is detected, the relative signal is output.

Pr.	Name	Initial value*1		Setting range	Description
		Gr.1	Gr.2		
41 M441	Up-to-frequency sensitivity	10%		0% to 100%	Set the level where the SU signal turns ON.
42 M442	Output frequency detection	6 Hz		0 to 590 Hz	Set the frequency at which the FU (or FB) signal turns ON.
43 M443	Output frequency detection for reverse rotation	9999		0 to 590 Hz	Set the frequency at which the FU (or FB) signal turns ON only while the motor rotates in reverse direction.
				9999	The frequency same as the Pr.42 setting is set.
865 M446	Low speed detection	1.5 Hz		0 to 590 Hz	Set the frequency at which the LS signal turns ON.
870 M440	Speed detection hysteresis	0 Hz		0 to 15 Hz	Set the hysteresis width for the detected frequency.

*1 Gr.1 and Gr.2 are the parameter initial value groups. (Refer to page 46.)

◆ Setting the notification zone of the output frequency reaching the set point (SU signal, Pr.41)

- The Up to frequency (SU) signal is output when the output frequency reaches the set frequency.
- Set the value in the range of 1% to 100% in **Pr.41** to determine tolerance for the set frequency (considered as 100% point).
- It may be useful to use this signal to start operating related equipment after checking that the set frequency has been reached.
- To use the SU signal, set "1" (positive logic) or "101" (negative logic) in any parameter from **Pr.190 to Pr.196 (Output terminal function selection)** to assign the function to an output terminal.

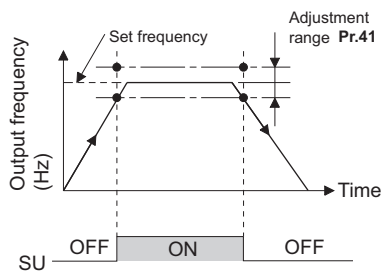

◆ Output frequency detection (FU (FB) signal, Pr.42, Pr.43)

- The Output frequency detection (FU) signal and the Speed detection (FB) signal are output when the output frequency reaches or exceeds the **Pr.42** setting.
- The FU signal is useful for applying or releasing electromagnetic brake, etc.
- The FU signal is output when the output frequency (frequency command) reaches the set frequency. The FB signal is output when the detected actual speed of the motor reaches the set frequency. The FU signal and the FB signal are output at the same manner under V/F control or Advanced magnetic flux vector control.
- The frequency detection dedicated to motor rotation in reverse direction is enabled by setting the frequency in **Pr.43**. This setting is useful when the timing of the electromagnetic braking during forward rotation operation (for example, during lifting up in the lifts operation) is different from that during reverse rotation operation (lifting down).
- When **Pr.43** ≠ "9999", the **Pr.42** setting is for the forward rotation operation and the **Pr.43** setting is for the reverse rotation operation.

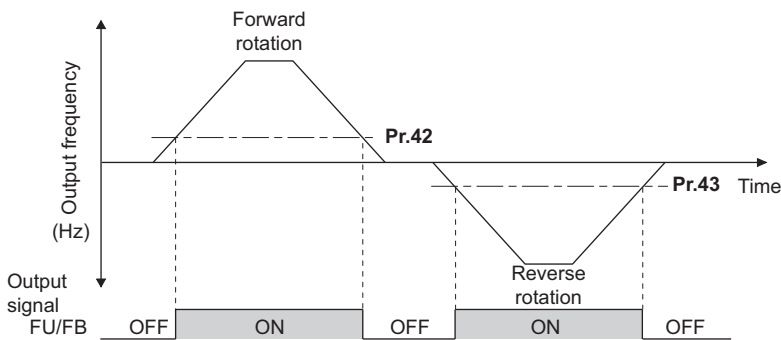

- To use each signal, set the corresponding number selected from the following table in any parameter from **Pr.190 to Pr.196 (Output terminal function selection)** to assign the function.

Output signal	Pr.190 to Pr.196 settings		Related parameter
	Positive logic	Negative logic	
FU	4	104	42, 43
FB	41	141	

◆ Low speed detection (LS signal, Pr.865)

- When the output frequency drops to the setting of **Pr.865 Low speed detection** or lower, the Low speed detection (LS) signal is output.
- The fault "E.OLT" displays and the inverter output shuts off if the torque limit operation causes the frequency to drop to the frequency set in **Pr.865** and the output torque to surpass the value set in **Pr.874 OLT level setting** for three seconds or longer in the speed control mode under PM sensorless vector control.
- For the LS signal, set "34" (positive logic) or "134" (negative logic) in any parameter from **Pr.190 to Pr.196 (Output terminal function selection)** to assign the function to an output terminal.

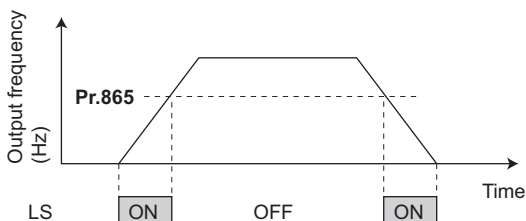

◆ Speed detection hysteresis (Pr.870)

This function prevents chattering of the speed detection signals. When an output frequency fluctuates, the following signals may chatter (turns ON and OFF repeatedly).

- Up to frequency (SU) signal
- Speed detection (FB) signal
- Low speed detection (LS) signal

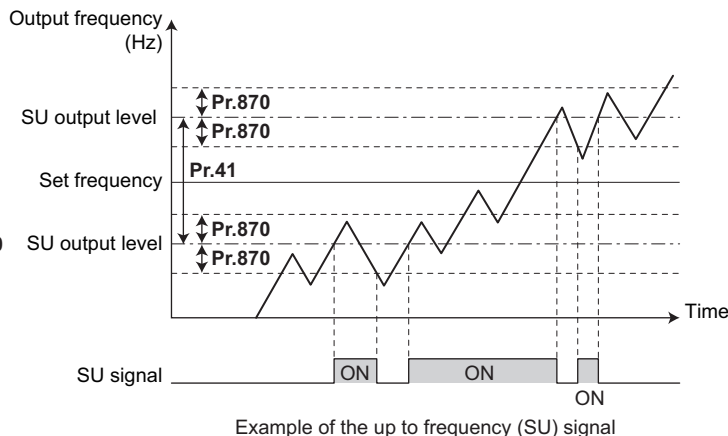
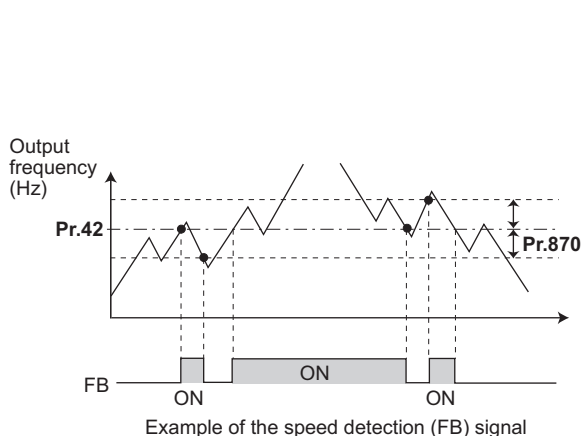

NOTE

- All signals are OFF during the DC injection brake operation and during tuning at start-up.
- The reference frequency in comparison with the set frequency differs depending on the control method.

Control method or function	Reference frequency	
	FU	FB, SU, LS
V/F control	Output frequency	Output frequency
Advanced magnetic flux vector control	Output frequency before the slip compensation	Output frequency before the slip compensation
PM sensorless vector control	Frequency command value	Estimated frequency (actual motor speed)

- Setting a higher value in **Pr.870** causes a lower responsivity of the signals for frequency detection (SU, FB, and LS signals).
- The logic (ON/OFF switching) of the LS signal is the reverse of that of the FB signal.
- Changing the terminal assignment using **Pr.190 to Pr.196 (Output terminal function selection)** may affect the other functions. Set parameters after confirming the function of each terminal.

Parameters referred to

Pr.190 to Pr.196 (Output terminal function selection) [page 226](#)

Pr.874 OLT level setting [page 87](#)

10.8 Output current detection function

If the inverter output current which reaches a specific value is detected during operation, the relative signal is output via an output terminal.

Pr.	Name	Initial value	Setting range	Description
150 M460	Output current detection level	150%	0% to 400%	Set the level to detect the output current. The inverter rated current is regarded as 100%.
151 M461	Output current detection signal delay time	0 s	0 to 10 s	Set the time from when the output current exceeds the Pr.150 setting until the Output current detection (Y12) signal is output.
152 M462	Zero current detection level	5%	0% to 400%	Set the level to detect the zero current. The inverter rated current is regarded as 100%.
153 M463	Zero current detection time	0.5 s	0 to 10 s	Set the time from when the output current falls below the Pr.152 setting until the Zero current detection (Y13) signal is output.
166 M433	Output current detection signal retention time	0.1 s	0 to 10 s	Set the retention time period during which the Y12 signal is ON.
				9999
167 M464	Output current detection operation selection	0	0, 1, 10, 11	Select the inverter operation at the time when the Y12 signal and the Y13 signal turn ON.

◆ Output current detection (Y12 signal, Pr.150, Pr.151, Pr.166, Pr.167)

- The output current detection function is useful for overtorque detection.
- If the inverter output during inverter running remains higher than the **Pr.150** setting for the time set in **Pr.151** or longer, the Output current detection (Y12) signal is output.
- When the Y12 signal turns ON, the ON state is retained for the time set in **Pr.166**.
- When **Pr.166** = "9999", the ON state is retained until the next start-up of the inverter.
- Setting **Pr.167** = "1" while the Y12 signal is ON does not cause the fault E.CDO. The **Pr.167** setting becomes valid after the Y12 signal is turned OFF.
- For the Y12 signal, set "12" (positive logic) or "112" (negative logic) in any parameter from **Pr.190 to Pr.196 (Output terminal function selection)** to assign the function to an output terminal.
- Use **Pr.167** to select the inverter operation at the time when Y12 signal turns ON, whether the inverter output stops or the inverter operation continues.

Pr.167 setting	When the Y12 signal turns ON	When the Y13 signal turns ON
0 (initial value)	Operation continues.	Operation continues.
1	Operation stops by fault (E.CDO).	Operation continues.
10	Operation continues.	Operation stops by fault (E.CDO).
11	Operation stops by fault (E.CDO).	Operation stops by fault (E.CDO).

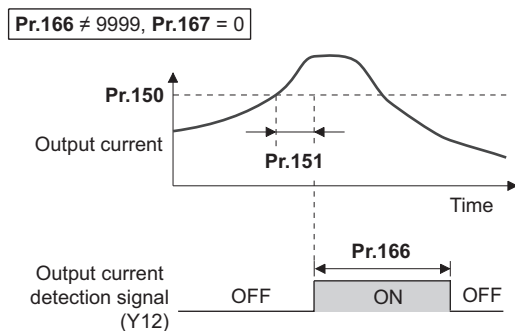

◆ Zero current detection (Y13 signal, Pr.152, Pr.153)

- If the inverter output during inverter running remains lower than the **Pr.152** setting for the time set in **Pr.153** or longer, the Zero current detection (Y13) signal is output.
- Once the Zero current detection (Y13) signal turns ON, the signal is retained ON for at least 0.1 second.
- If the inverter output current decreases, slippage due to gravity may occur, especially in a lift application, because the motor torque decreases. To prevent this, the Y13 signal can be output from the inverter to apply the mechanical brake when the output current falls below the **Pr.152** setting.
- For the Y13 signal, set "13" (positive logic) or "113" (negative logic) in any parameter from **Pr.190 to Pr.196 (Output terminal function selection)** to assign the function to an output terminal.
- Use **Pr.167** to select the inverter operation at the time when Y13 signal turns ON, whether the inverter output stops or the inverter operation continues.

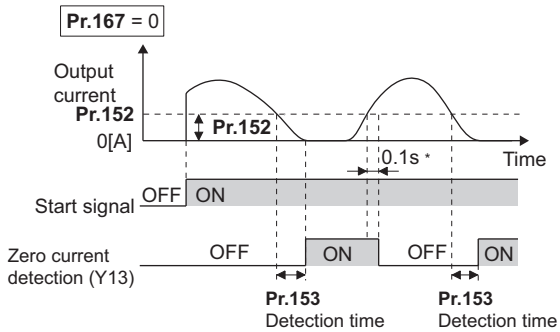

* When the output is restored to the **Pr.152** level, the Y13 signal is turned OFF after 0.1 s.

NOTE

- This function is enabled during offline auto tuning.
- The response time of the Y12 and Y13 signals is approximately 0.1 second. However, the response time varies according to the load condition.
- When **Pr.152** = "0", the zero current detection function is disabled.
- Changing the terminal assignment using **Pr.190 to Pr.196 (Output terminal function selection)** may affect the other functions. Set parameters after confirming the function of each terminal.

CAUTION

- The setting of the zero current detection level should not be too low, and the setting of the zero current detection time should not be too long. Doing so may cause the signal for the zero current detection not to be output when the output current is very low and the motor torque is not generated.
- A safety backup such as an emergency brake must be provided to prevent machines or equipment in hazardous conditions even if the Zero current detection signal is used.

Parameters referred to

Offline auto tuning [page 266, page 274](#)

Pr.190 to Pr.196 (Output terminal function selection) [page 226](#)

10.9 Remote output function

The signal can be turned ON or OFF via the output terminal on the inverter as if the terminal is the remote output terminal for a programmable controller.

Pr.	Name	Initial value	Setting range	Description	
495 M500	Remote output selection	0	0	Remote output data is cleared when the inverter power is turned OFF.	Remote output data is cleared during an inverter reset.
			1	Remote output data is retained even after the inverter power is turned OFF.	
			10	Remote output data is cleared when the inverter power is turned OFF.	Remote output data is retained during an inverter reset.
			11	Remote output data is retained even after the inverter power is turned OFF.	
496 M501	Remote output data 1	0	0 to 4095	Set a decimal number to enter a binary number in every bit corresponding to each of the output terminals of the inverter or communication.	

◆ Remote output setting (REM signal, Pr.496)

- The signal assigned to each of the output terminal can be turned ON or OFF according to the setting of **Pr.496**. The signal assigned to each of the remote output terminal can be turned ON or OFF through communication.
- For the Remote output (REM) signal, set "96" (positive logic) or "196" (negative logic) in any parameter from **Pr.190 to Pr.192 (Output terminal function selection)** to assign the function to an output terminal.
- Refer to the following figure to check correspondences between the bit and the actual terminal. When "1" is set in the bit corresponding to the terminal to which the REM signal assigned by setting a number in **Pr.496**, the signal turns ON (or OFF in negative logic setting). Also, setting "0" allows the signal to turn OFF (or ON in negative logic setting).
- For example, when **Pr.190 RUN terminal function selection** = "96" (positive logic) and "1" (H01) is set in **Pr.496**, the signal assigned to terminal RUN turns ON.

Pr.496

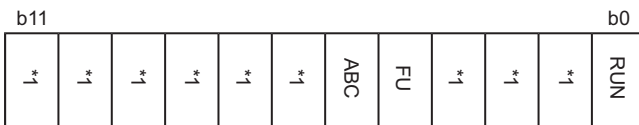

◆ Remote output data retention (REM signal, Pr.495)

- When the inverter power is reset (or a power failure occurs) while **Pr.495** = "0 (initial value) or 10", the REM signal setting is cleared. (The ON/OFF state of the signal assigned to each terminal is determined by the settings in **Pr.190 to Pr.192**.) The setting in **Pr.496** is reset to "0".
- When **Pr.495** = "1 or 11", the remote output data is stored in EEPROM before the inverter power is turned OFF. This means that the signal output setting after power restoration is the same as that before the power was turned OFF. However, when **Pr.495** = "1", the data during an inverter reset (terminal reset or reset request via communication) is not saved.
- When **Pr.495** = "10 or 11", the remote output data in the signal before the reset is stored even during an inverter reset.

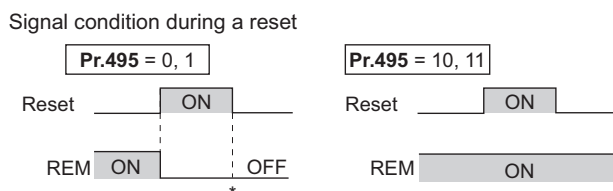
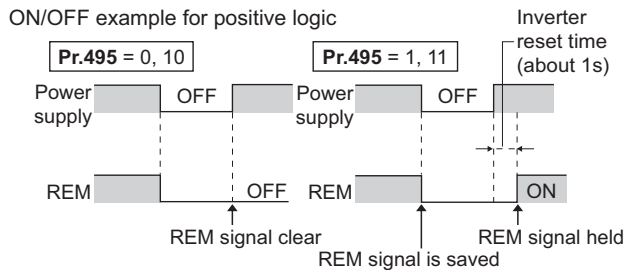

* When **Pr.495** = "1", the signal condition saved in EEPROM (condition of the last power OFF) is applied.

NOTE

- The output terminal to which the REM signal is not assigned by using **Pr.190 to Pr.192** does not turn ON or OFF when "1 or 0" is set in bit corresponding to each of the terminals by using **Pr.496**. (ON/OFF command affects only the terminal to which the signal is assigned.)
- If the power supply is turned OFF during an inverter reset, the remote output data is not stored even when **Pr.495** = "1 or 11".

Parameters referred to

Pr.190 to Pr.196 (Output terminal function selection) [page 226](#)

10.10 Pulse train output of output power

Every time when the output energy amount, which is accumulated from the time at power ON, after an inverter reset, or after the **Pr.799 Pulse increment setting for output power** is changed, reaches the specified value (or its integral multiples), the Y79 signal is output in pulses.

Pr.	Name	Initial value	Setting range	Description
799 M520	Pulse increment setting for output power	1 kWh	0.1 kWh, 1 kWh, 10 kWh, 100 kWh, 1000 kWh	The signal is output in pulses every time when the output energy increments by the set amount of energy (kWh).

◆ Pulse increment setting for output power (Y79 signal, Pr.799)

- The Y79 pulse output signal is output every time when the inverter output energy exceeds the **Pr.799 Pulse increment setting for output power** after power-ON or inverter reset.
- The inverter does not clear and continues to count the amount of the output energy when the automatic restart after instantaneous power failure (the one that will not cause an inverter reset) occurs or the retry function is activated.
- If a power failure occurs, the cumulative value is reset to 0 kWh and restart cumulating.
- To use the Y79 signal, set "79" (positive logic) or "179" (negative logic) in any parameter from **Pr.190 to Pr.196 (Output terminal function selection)** to assign the function.

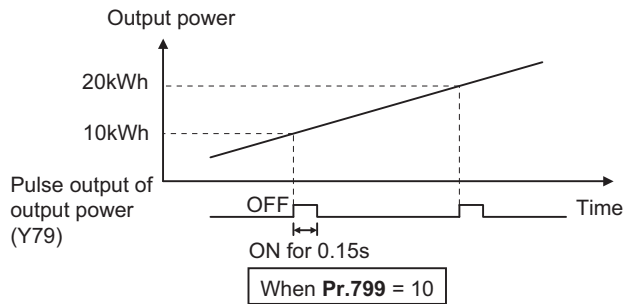

NOTE

- Because the accumulated data in the inverter is cleared when control power is lost by power failure or at an inverter reset, the value on the monitor cannot be used to charge electricity bill.
- Changing the terminal assignment using **Pr.190 to Pr.196 (Output terminal function selection)** may affect the other functions. Set parameters after confirming the function of each terminal. (Refer to [page 226](#).)
- In an application where the pulse outputs are frequently turned ON/OFF, do not assign a signal to terminals A, B, and C. Doing so may shorten the life of the relay contact.

Parameters referred to

Pr.190 to Pr.196 (Output terminal function selection) [page 226](#)

10.11 Detection of control circuit temperature

The temperature of the control circuit board can be monitored, and a signal can be output according to a predetermined temperature setting.

Pr.	Name	Initial value	Setting range	Description
663 M060	Control circuit temperature signal output level	0°C	0°C to 100°C	Set the temperature where the Y207 signal turns ON.

◆ Control circuit temperature monitoring

- The temperature of the control circuit board can be monitored within the range of 0°C to 100°C on the operation panel or via terminal AM. Refer to [page 208](#) for information on how to select the monitor item.
- The monitor value is a rough approximation of the change in the surrounding air temperature of the inverter. Use this parameter to grasp the operating environment of the inverter.

◆ Control circuit temperature detection (Pr.663, Y207 signal)

- The Y207 signal can be output when the control circuit temperature reaches the **Pr.663** setting or higher.
- For the Y207 signal, set "207" (positive logic) or "307" (negative logic) in any parameter from **Pr.190 to Pr.196 (Output terminal function selection)** to assign the function to an output terminal.

NOTE

- The Y207 signal is turned OFF when the control circuit temperature becomes 5°C or more lower than the **Pr.663** setting.
- Changing the terminal assignment using **Pr.190 to Pr.196 (Output terminal function selection)** may affect the other functions. Set parameters after confirming the function of each terminal.

Parameters referred to

Pr.158 AM terminal function selection [page 216](#)

Pr.190 to Pr.196 (Output terminal function selection) [page 226](#)

11 (T) Multi-Function Input Terminal Parameters

Purpose	Parameter to set			Refer to page
To inverse the rotation direction with the voltage/current analog input selection (terminals 2 and 4)	Analog input selection	P.T000, P.T001	Pr.73, Pr.267	243
To eliminate noise on analog inputs	Analog input filter	P.T002	Pr.74	247
To adjust analog input frequency/voltage (current) (calibration)	Frequency setting voltage (current) bias and gain	P.T200 to P.T203, P.T400 to P.T403, P.M043	Pr.125, Pr.126, Pr.241, C2 to C7 (Pr.902 to Pr.905)	248
To assign functions to input terminals	Input terminal function selection	P.T700 to P.T704, P.T740, P.T751 to P.T755	Pr.178 to Pr.182, Pr.185 to Pr.189, Pr.699	252
To change the input specification (NO/NC contact) of input signals	Output stop signal (MRS) / Inverter run enable signal (X10) input selection	P.T720	Pr.17	255
To assign start and forward/reverse commands to different signals	Start signal (STF/STR) operation selection	P.G106	Pr.250	258

11.1 Analog input selection

The functions to switch the analog input terminal specifications and forward/reverse rotation by the input signal polarity are selectable.

Pr.	Name	Initial value	Setting range	Description	
73 T000	Analog input selection	1	0, 1, 10, 11	SW1: V (initial status)	The terminal 2 input specification (0 to 5 V, 0 to 10 V, 0 to 20 mA) is selectable. Also the reversible operation setting is selectable.
			6, 16	SW1: I	
267 T001	Terminal 4 input selection	0	0	SW2: I (initial status)	Terminal 4 input, 4 to 20 mA
			1	SW2: V	Terminal 4 input, 0 to 5 V
			2		Terminal 4 input, 0 to 10 V

◆ Analog input specification selection

- For terminals 2 and 4 used for analog input, the voltage input (0 to 5 V, 0 to 10 V) and current input (0 to 20 mA) are selectable. To change the input specification, change the setting of **Pr.73 (Pr.267)** and the voltage/current input switch (SW1 or SW2).

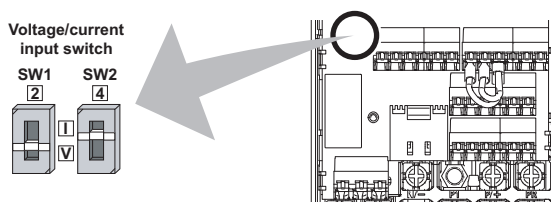

Switch state	Input specification	Input terminal	Rated specification
SW1	I	Terminal 2	For voltage input, the input resistance is $10 \pm 1 \text{ k}\Omega$ and the maximum permissible voltage is 20 VDC. For current input, the input resistance is $245 \pm 5 \Omega$ and the maximum permissible current is 30 mA.
	V		
SW2	I	Terminal 4	
	V		

- Change the setting of the voltage/current input switch to change the rated specification of terminal 2 or 4.

- Set **Pr.73 (Pr.267)** and the voltage/current input switch according to the analog signal input. The incorrect settings shown in the following table cause a failure. The inverter does not operate properly with other incorrect settings.

Setting causing a failure		Operation
Switch setting	Terminal input	
I (current input)	Voltage input	Causes an analog signal output circuit failure in an external device (due to increased loads on the signal output circuit of the external device).
V (voltage input)	Current input	Causes an input circuit failure in the inverter (due to an increased output power in the analog signal output circuit of an external device).

Set **Pr.73** and the voltage/current input switch (SW1) according to the following table.

Pr.73 setting	Terminal 2 input	SW1	Reversible operation
0	0 to 10 V	V	Disabled
1 (initial value)	0 to 5 V	V	
6	0 to 20 mA	I	
10	0 to 10 V	V	Enabled
11	0 to 5 V	V	
16	0 to 20 mA	I	

- When the Terminal 4 input selection (AU) signal is turned ON, terminal 4 is used to set the main speed. In this case, terminal 2 is not used to set the main speed.

Set **Pr.267** and the voltage/current input switch (SW2) according to the following table.

Pr.267 setting	Terminal 4 input	SW2	Reversible operation
0 (initial value)	4 to 20 mA	I	Determined by Pr.73 setting
1	0 to 5 V	V	
2	0 to 10 V	V	

NOTE

- To enable terminal 4, turn ON the AU signal.
- Set the parameters and the switch settings so that they agree. Incorrect setting may cause a fault, failure, or malfunction.
- Use **Pr.125 (Pr.126) (frequency setting gain)** to change the maximum output frequency at the input of the maximum output frequency command voltage (current). At this time, the command voltage (current) need not be input. Also, the acceleration/deceleration time, which is a slope up/down to the acceleration/deceleration reference frequency, is not affected by the change in **Pr.73** setting.
- Always calibrate the input after changing the voltage/current input signal with **Pr.73 (Pr.267)** and the voltage/current input switch.
- When **Pr.561 PTC thermistor protection level** ≠ "9999", terminal 2 is not used for the analog frequency command.

◆ Running with analog input voltage

- For the frequency setting signal, input 0 to 5 VDC (or 0 to 10 VDC) between terminals 2 and 5. The 5 V (10 V) input is the maximum output frequency.
- The power supply 5 V (10 V) can be input by either using the internal power supply or preparing an external power supply. The internal power supply is 5 VDC output via terminal 10.

Terminal	Inverter internal power source voltage	Frequency setting resolution	Pr.73 (terminal 2 input voltage)
10	5 VDC	0.030/60 Hz	0 to 5 VDC input

- To supply the 10 VDC input to terminal 2, set "0 or 10" in **Pr.73**. (The initial value is 0 to 5 V.)
- Set "1 (0 to 5 VDC)" or "2 (0 to 10 VDC)" in **Pr.267** and set the voltage/current input switch to "V" in order to input voltage through terminal 4. Turning ON the AU signal activates the terminal 4 input.

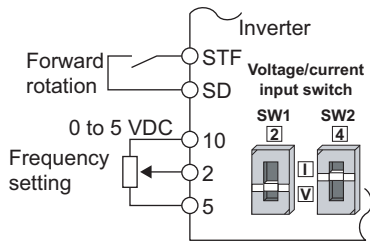

Connection diagram using terminal 2 (0 to 5 VDC)

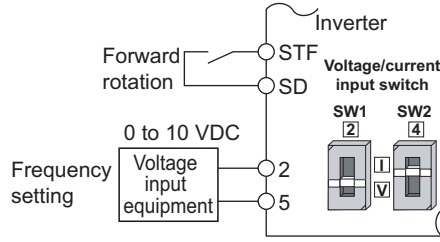

Connection diagram using terminal 2 (0 to 10 VDC)

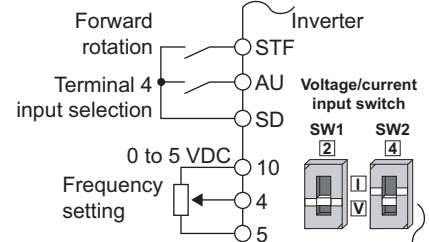

Connection diagram using terminal 4 (0 to 5 VDC)

NOTE

- The wiring length of terminal 10, 2, and 5 should be 30 m at maximum.

◆ Running with analog input current

- For constant pressure or temperature control with fans, pumps, or other devices, automatic operation is available by setting the regulator output signal 4 to 20 mADC to between terminals 4 and 5.
- To use terminal 4, the AU signal needs to be turned ON.

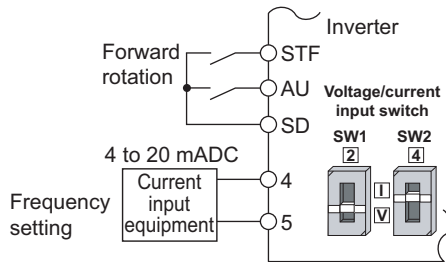

Connection diagram using terminal 4 (4 to 20 mADC)

- Set "6 or 16" in **Pr.73** and set the voltage/current input switch to "I" in order to input current through terminal 2. In this case, the AU signal does not need to be turned ON.

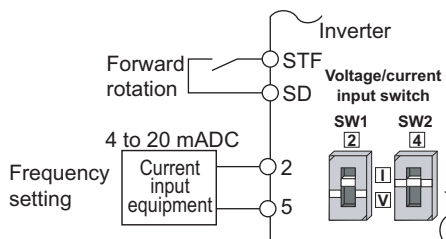

Connection diagram using terminal 2 (4 to 20 mADC)

◆ Performing forward/reverse rotation with the analog input (reversible operation)

- The reversible operation by terminal 2 (terminal 4) is enabled by setting "10, 11, or 16" in **Pr.73** and adjusting **Pr.125 (Pr.126) Terminal 2 frequency setting gain frequency (Terminal 4 frequency setting gain frequency), C2 (Pr.902) Terminal 2 frequency setting bias frequency to C7 (Pr.905) Terminal 4 frequency setting gain**.
- The following shows the reversible operation by terminal 2 (0 to 5 V) input.
 - 1) Set "11" in **Pr.73** to enable the reversible operation.
 - 2) Set the frequency at 2.5 V analog input in **C2 (Pr.902)** and the frequency at maximum analog input in **Pr.125**.
 - 3) Set 1/2 of the **C4 (Pr.903)** setting value (unit: %) in **C3 (Pr.902)**.
 - 4) Reverse operation is performed when 0 to 2.5 VDC is input, and forward rotation when 2.5 to 5 VDC.

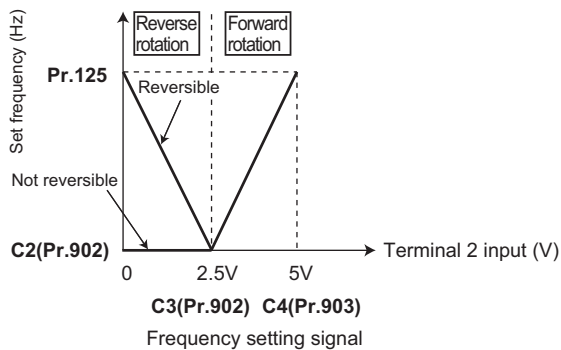

Example of reversible operation

NOTE

- Note that the reverse rotation operation is performed when analog input stops (only the start signal is input) while the reversible operation is set.
- When the reversible operation is enabled, the reversible operation by terminal 4 is performed in the initial setting (reverse operation is performed when 0 to 4 mA is input, and forward operation when 4 to 20 mA).

Parameters referred to

Pr.125 Terminal 2 frequency setting gain frequency, Pr.126 Terminal 4 frequency setting gain frequency [page 248](#)
Pr.561 PTC thermistor protection level [page 166](#)

11.2 Response level of analog input and noise elimination

The response level and stability of frequency command using the analog input signal (terminal 2 or 4) can be adjusted.

Pr.	Name	Initial value	Setting range	Description
74 T002	Input filter time constant	1	0 to 8	Set the primary delay filter time constant to the analog input command. If the setting is too large, response becomes slow.

◆ Analog input time constant (Pr.74)

- Use this parameter to eliminate noise on the frequency setting circuit.
- Increase the filter time constant if the operation is unstable due to noise or other factors.

If the setting is too large, response becomes slow.

Pr.74 setting	Time constant
0	Average of values for two travels
1	10 ms
2	20 ms
3	40 ms
4	80 ms
5	160 ms
6	320 ms
7	640 ms
8	1280 ms

NOTE

- The analog input filter is invalid (no filter) during PID control operation.

11.3 Frequency setting voltage (current) bias and gain

The magnitude (slope) of the output frequency can be set as desired in relation to the frequency setting signal (0 to 5 VDC, 0 to 10 VDC, or 4 to 20 mA). Use **Pr.73 Analog input selection (Pr.267 Terminal 4 input selection)** and the voltage/current input switch to switch among input of 0 to 5 VDC, 0 to 10 VDC, and 0 to 20 mA. (Refer to [page 243](#).)

Pr.	Name	Initial value ^{*2}		Setting range	Description	
		Gr.1	Gr.2			
C2 (902) T200 ^{*1}	Terminal 2 frequency setting bias frequency	0 Hz		0 to 590 Hz	Set the bias frequency for the terminal 2 input.	
C3 (902) T201 ^{*1}	Terminal 2 frequency setting bias	0%		0% to 300%	Set the converted % of the bias voltage (current) for the terminal 2 input.	
125 (903) T202 T022 ^{*1}	Terminal 2 frequency setting gain frequency	60 Hz	50 Hz	0 to 590 Hz	Set the gain (maximum) frequency for the terminal 2 input.	
C4 (903) T203 ^{*1}	Terminal 2 frequency setting gain	100%		0% to 300%	Set the converted % of the gain voltage (current) for the terminal 2 input.	
C5 (904) T400 ^{*1}	Terminal 4 frequency setting bias frequency	0 Hz		0 to 590 Hz	Set the bias frequency for the terminal 4 input.	
C6 (904) T401 ^{*1}	Terminal 4 frequency setting bias	20%		0% to 300%	Set the converted % of the bias current (voltage) for the terminal 4 input.	
126 (905) T402 T042 ^{*1}	Terminal 4 frequency setting gain frequency	60 Hz	50 Hz	0 to 590 Hz	Set the gain (maximum) frequency for the terminal 4 input.	
C7 (905) T403 ^{*1}	Terminal 4 frequency setting gain	100%		0% to 300%	Set the converted % of the gain current (voltage) for the terminal 4 input.	
241 M043	Analog input display unit switchover	0		0	% display	Select the unit for analog input display.
				1	V/mA display	

*1 On the LCD operation panel or the parameter unit used as the command source, the parameter number in parentheses appears.

*2 Gr.1 and Gr.2 are the parameter initial value groups. (Refer to [page 46](#).)

◆ Changing the frequency for the maximum analog input (Pr.125, Pr.126)

- Use **Pr.125 (Pr.126)** to change the frequency setting (gain) for the maximum analog input voltage (current). (C2 (Pr.902) to C7 (Pr.905) settings need not be changed.)

◆ Analog input bias/gain calibration (C2 (Pr.902) to C7 (Pr.905))

- The "bias" and "gain" functions serve to adjust the relationship between a setting input signal and the output frequency. A setting input signal is such as a 0 to 5 VDC, 0 to 10 VDC, or 4 to 20 mA signal externally input to set the output frequency.
- Set the bias frequency of the terminal 2 input using **C2 (Pr.902)**. (It is initially set to the frequency at 0 V.)
- Use **Pr.125** to set the output frequency to the frequency command voltage (current) set by **Pr.73 Analog input selection**.
- Set the bias frequency of the terminal 4 input using **C5 (Pr.904)**. (It is initially set to the frequency at 4 mA.)
- Use **Pr.126** to set the output frequency to the 20 mA input of the frequency command current (4 to 20 mA).

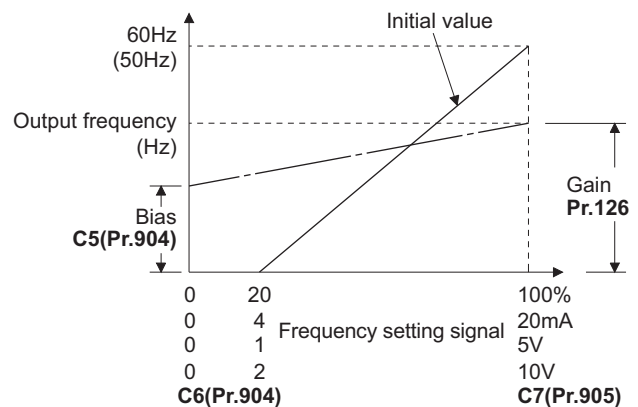
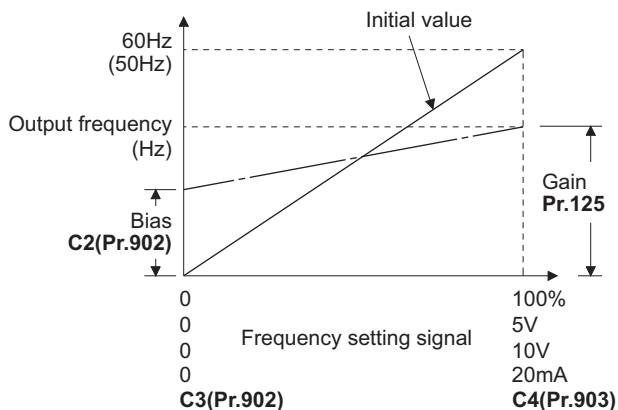

- There are three methods to adjust the bias/gain frequency setting voltage (current).
Adjustment by applying voltage (current) between terminals 2 and 5 (4 and 5) to set the voltage (current) at the bias/gain frequency. [page 249](#)
- Adjustment by selecting the voltage (current) at the bias/gain frequency without applying voltage (current) between terminals 2 and 5 (4 and 5). [page 250](#)
- Adjustment by changing the frequency without adjusting the voltage (current). [page 251](#)

NOTE

- Always calibrate the input after changing the voltage/current input signal with **Pr.73 (Pr.267)** and the voltage/current input switch.

◆ Display unit changing for analog input (Pr.241)

- The analog input display unit (%V/mA) can be changed for analog input bias/gain calibration.
- Depending on the terminal input specification setting of **Pr.73 (Pr.267)** and the voltage/current input switch, the unit of the displayed value of **C3 (Pr.902)**, **C4 (Pr.903)**, **C6 (Pr.904)** and **C7 (Pr.905)** changes as shown below:

Analog command (via terminal 2 or 4) (depending on the settings of Pr.73 (Pr.267) and the voltage/current input switch)	Pr.241 = "0 (initial value)"	Pr.241 = "1"
0 to 5 V input	0% to 100% (0.1%)	0 to 5 V (0.01 V)
0 to 10 V input	0% to 100% (0.1%)	0 to 10 V (0.01 V)
0 to 20 mA input	0% to 100% (0.1%)	0 to 20 mA (0.01 mA)

◆ Frequency setting voltage (current) bias/gain adjustment method

■ Adjustment by applying voltage (current) between terminals 2 and 5 (4 and 5) to set the voltage (current) at the bias/gain frequency (Example of adjustment at the gain frequency)

Operating procedure

1. Turning ON the power of the inverter
The operation panel is in the monitor mode.
 2. Changing the operation mode
Press the HAND/AUTO key to choose the PU operation mode. The HAND LED turns ON.
 3. Selecting the parameter setting mode
Press the MODE key to choose the parameter setting mode. (The parameter number read previously appears.)
 4. Calibration parameter selection
Turn the setting dial until "C..." appears. Press the SET key to display "C---".
 5. Selecting a parameter
Turn the setting dial until "C4" (**C4 (Pr.903) Terminal 2 frequency setting gain**) appears for terminal 2, or "C7" (**C7 (Pr.905) Terminal 4 frequency setting gain**) for terminal 4.
 6. Analog voltage (current) display
Press the SET key to display the analog voltage (current) value (%) currently applied to terminal 2 (terminal 4).
Do not touch the setting dial until calibration is completed.
 7. Voltage (current) application
Apply 5 V (20 mA). (Turn the external potentiometer connected between terminals 2 and 5 (terminals 4 and 5) to a desired position.)
 8. Setting completed
Press the SET key to confirm the setting. The analog voltage (current) value (%) blinks when it is applied.
- Turn the setting dial to read another parameter.
 - Press the SET key to return to the "C---" display.
 - Press the SET key twice to show the next parameter.

■ Adjustment by selecting the voltage (current) at the bias/gain frequency without applying voltage (current) between terminals 2 and 5 (4 and 5) (Example of adjustment at the gain frequency)

Operating procedure

- 1.** Turning ON the power of the inverter
The operation panel is in the monitor mode.
- 2.** Changing the operation mode
Press the HAND/AUTO key to choose the PU operation mode. The HAND LED turns ON.
- 3.** Selecting the parameter setting mode
Press the MODE key to choose the parameter setting mode. (The parameter number read previously appears.)
- 4.** Calibration parameter selection
Turn the setting dial until "C..." appears. Press the SET key to display "C----".
- 5.** Selecting a parameter
Turn the setting dial until "C4" (**C4 (Pr.903) Terminal 2 frequency setting gain**) appears for terminal 2, or "C7" (**C7 (Pr.905) Terminal 4 frequency setting gain**) for terminal 4.
- 6.** Analog voltage (current) display
Press the SET key to display the analog voltage (current) value (%) currently applied to terminal 2 (terminal 4).
- 7.** Analog voltage (current) adjustment
After the setting dial is turned, the gain voltage (current) value (%) currently set to the parameter appears.
Turn the setting dial until the gain voltage (current) to be adjusted appears.
- 8.** Setting completed
Press the SET key to confirm the setting. The analog voltage (current) value (%) blinks when it is applied.
 - Turn the setting dial to read another parameter.
 - Press the SET key to return to the "C----" display.
 - Press the SET key twice to show the next parameter.

NOTE

- The present frequency setting bias/gain setting can be checked by pressing the setting dial after step 6. The setting cannot be checked after step 7.

■ Adjustment by changing the frequency without adjusting the voltage (current) (Example of changing the gain frequency from 60 Hz to 50 Hz)

Operating procedure

- 1.** Selecting the parameter
Turn the setting dial until "P.125" (**Pr.125**) appears for terminal 2, or "P.126" (**Pr.126**) for terminal 4.
Press the SET key to show the present set value. (60.00 Hz)
- 2.** Changing the maximum frequency
Turn the setting dial to change the value to "50.00". (50.00 Hz)
Press the SET key to confirm the setting. "50.00" blinks.
- 3.** Selecting the mode and the monitor item
Press the MODE key three times to select the monitor mode and to monitor a frequency.
- 4.** Start
Turn ON the start switch (STF/STR signal), and turn the frequency setting potentiometer clockwise slowly to full.
(Refer to steps 2 and 3 in [page 27](#).)
The motor is operated at 50 Hz.

NOTE

- If the frequency meter (display meter) connected to terminal AM does not indicate exactly 60 Hz, set the calibration parameter **C1 (Pr.901)**. (Refer to [page 218](#).)
- If the voltage (current) values at the gain and bias frequencies are too close to each other, an error "Er3" may be indicated.
- Changing **C4 (Pr.903)** or **C7 (Pr.905)** (gain adjustment) will not change **Pr.20**.
- To set the value to 120 Hz or higher, the **Pr.18 High speed maximum frequency** needs to be 120 Hz or higher. (Refer to [page 191](#).)
- Use the calibration parameter **C2 (Pr.902)** or **C5 (Pr.904)** to set the bias frequency. (Refer to [page 248](#).)
- For operation outline of the parameter unit (FR-PU07), refer to the FR-PU07 Instruction Manual.

⚠ CAUTION

- Be cautious when setting any value other than "0" as the bias frequency at 0 V (0 mA). Even if a speed command is not given, simply turning ON the start signal will start the motor at the preset frequency.

« Parameters referred to »

Pr.1 Maximum frequency, Pr.18 High speed maximum frequency  [page 191](#)

Pr.20 Acceleration/deceleration reference frequency  [page 130](#)

Pr.73 Analog input selection, Pr.267 Terminal 4 input selection  [page 243](#)

Pr.79 Operation mode selection  [page 142](#)

11.4 Input terminal function selection

Use the following parameters to change the input terminal functions.

Pr.	Name	Initial value	Initial signal	Setting range
178 T700	STF terminal function selection	60	STF (Forward rotation command)	0 to 5, 7, 8, 10, 12, 14, 16, 18, 23 to 25, 27, 30, 37, 46, 47, 60, 62, 64 to 67, 72, 84, 9999
179 T701	STR terminal function selection	61	STR (Reverse rotation command)	
180 T702	RL terminal function selection	0	RL (Low-speed operation command)	
181 T703	RM terminal function selection	1	RM (Middle-speed operation command)	
182 T704	RH terminal function selection	2	RH (High-speed operation command)	
185 T751	NET X1 input selection	9999	No function	
186 T752	NET X2 input selection	9999	No function	
187 T753	NET X3 input selection	9999	No function	
188 T754	NET X4 input selection	9999	No function	
189 T755	NET X5 input selection	9999	No function	

Pr.	Name	Initial value	Setting range	Description
699 T740	Input terminal filter	9999	5 to 50 ms	Set the time delay for the input terminal response.
			9999	No filter for the input terminal

◆ Input terminal function assignment

- Signals can be input to the inverter by using physical terminals or via communication.
- Use parameters to assign functions to input terminals. Check the terminal available for each parameter.

Pr.	Terminal name	External input terminal (physical terminal)	Input via communication ^{*1}
178	STF	○	Forward rotation command only
179	STR	○	Reverse rotation command only
180	RL	○	○
181	RM	○	○
182	RH	○	○
185	NET X1	—	○
186	NET X2	—	○
187	NET X3	—	○
188	NET X4	—	○
189	NET X5	—	○

○: Assignment/input available, —: Assignment/input unavailable (no function)

*1 The communication protocol affects which terminals can be used. For details, refer to the Instruction Manual (Communication).

◆ Input signal list

- Refer to the following table and set the parameters.

Setting	Signal name	Function		Related parameter	Refer to page
0	RL	Pr.59 = "0 (initial value)"	Low-speed operation command	Pr.4 to Pr.6, Pr.24 to Pr.27, Pr.232 to Pr.239	163
		Pr.59 ≠ "0" ^{*1}	Remote setting (setting clear)	Pr.59	135
1	RM	Pr.59 = "0 (initial value)"	Middle-speed operation command	Pr.4 to Pr.6, Pr.24 to Pr.27, Pr.232 to Pr.239	163
		Pr.59 ≠ "0" ^{*1}	Remote setting (deceleration)	Pr.59	135
2	RH	Pr.59 = "0 (initial value)"	High-speed operation command	Pr.4 to Pr.6, Pr.24 to Pr.27, Pr.232 to Pr.239	163
		Pr.59 ≠ "0" ^{*1}	Remote setting (acceleration)	Pr.59	135
3	RT	Second function selection		Pr.44 to Pr.48, Pr.51, Pr.450, etc.	257
4	AU	Terminal 4 input selection		Pr.267	243
5	JOG	Jog operation selection		Pr.15, Pr.16	161
7	OH	External thermal relay input ^{*2}		Pr.9	166
8	REX	15-speed selection (Combination with multi-speeds of RL, RM, and RH)		Pr.4 to Pr.6, Pr.24 to Pr.27, Pr.232 to Pr.239	163
10	X10	Inverter run enable (FR-XC/FR-HC2 connection)		Pr.17, Pr.30, Pr.70	340
12	X12	PU operation external interlock		Pr.79	142
14	X14	PID control valid		Pr.127 to Pr.134, Pr.575 to Pr.577	283
16	X16	PU/External operation switchover (External operation with X16-ON)		Pr.79, Pr.340	142
18	X18	V/F switchover (V/F control with X18-ON)		Pr.80, Pr.81, Pr.800	72
23	LX	Pre-excitation		Pr.10 to Pr.12, Pr.795	335
24	MRS	Output stop		Pr.17	255
25	STOP	Start self-holding selection		Pr.250	258
27	TL	Torque limit selection		Pr.815	87
30	JOG2	Jog operation selection 2		Pr.15, Pr.16	161
37	X37	Traverse function selection		Pr.592 to Pr.597	281
46	TRG	Trace trigger input		Pr.1020 to Pr.1047	320
47	TRC	Trace sampling start/end		Pr.1020 to Pr.1047	320
60	STF	Forward rotation command (assignable to terminal STF (Pr.178) only)		Pr.250	258
61	STR	Reverse rotation command (assignable to terminal STR (Pr.179) only)		Pr.250	258
62	RES	Inverter reset		Pr.75	97
64	X64	PID forward/reverse action switchover		Pr.127 to Pr.134, Pr.575 to Pr.577	283
65	X65	PU/NET operation switchover (PU operation with X65-ON)		Pr.79, Pr.340	142
66	X66	External/NET operation switchover (NET operation with X66-ON)		Pr.79, Pr.340	142
67	X67	Command source switchover (command by Pr.338 or Pr.339 enabled with X67-ON)		Pr.338, Pr.339	153
72	X72	PID P control switchover		Pr.127 to Pr.134, Pr.575 to Pr.577	283
84	X84	Emergency drive execution command		Pr.514, Pr.515, Pr.523, Pr.524, Pr.1013	182
9999	—	No function		—	—

*1 When **Pr.59 Remote function selection** ≠ "0", functions of the RL, RM, and RH signals are changed as shown in the table.

*2 The OH signal is activated when the relay contact is open.

NOTE

- The same function can be assigned to two or more terminals. In this case, the logic of terminal input is OR.
- The priority of the frequency command given by the external signals is as follows: JOG operation (JOG/JOG2 signal) > multi-speed operation (RL/RM/RH/REX signal) > PID control (X14 signal) > terminal 4 analog input (AU signal) > pulse train input > terminal 2 analog input.
- When the Inverter run enable (X10) signal is not assigned, or when the PU operation external interlock (X12) signal is not assigned while **Pr.79 Operation mode selection** = "7", the MRS signal performs the same function.
- The same terminals are used to assign the multi-speed (7-speed) setting and the remote setting. The multi-speed setting and the remote setting cannot be assigned separately.
- When **Pr.291 Pulse train input selection** = "1" (pulse train input), terminal RM is used as a pulse train input terminal, independently of the setting of **Pr.181 RM terminal function selection**. (Refer to [page 159](#).)
- When the terminal assignment is changed using **Pr.178 to Pr.182** and **Pr.185 to Pr.189 (Input terminal function selection)**, wiring may be mistaken due to different terminal name and signal contents, or may affect other functions. Set parameters after confirming the function of each terminal.

◆ Adjusting the response of input terminals (Pr.699)

- Response of the input terminals (physical terminals) can be delayed in a range between 5 to 50 ms. (The following is the operation example of the STF signal.)

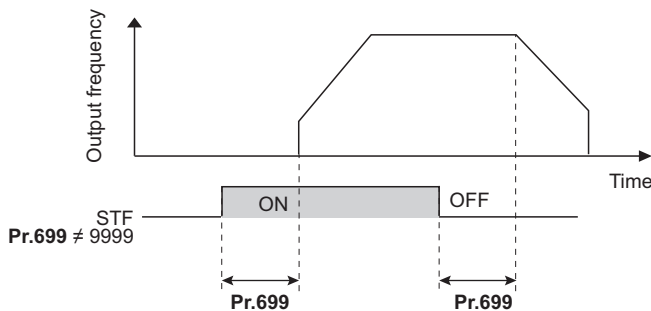

NOTE

- The **Pr.699** setting is invalid (no filter) for the following signals.
 - Input signals which are already in the ON state when the power is turned ON
 - Inverter run enable (X10) signal or Output stop (MRS) signal (when output is shut off)

11.5 Inverter output shutoff

The inverter output can be shut off with the MRS signal. The logic of the MRS signal can also be selected.

Pr.	Name	Initial value	Setting range	Description	
				MRS signal input	X10 signal input ^{*1}
17 T720	MRS/X10 terminal input selection	0	0	Normally open input	Normally open input
			1		Normally closed input (NC contact input specification)
			2	Normally closed input (NC contact input specification)	Normally open input
			3		Normally closed input (NC contact input specification)
			4	External terminal: Normally closed input (NC contact input specification) Communication: Normally open input	Normally open input
5	Normally closed input (NC contact input specification)				

*1 Refer to page 340 for details on the X10 signal.

◆ Output shutoff signal (MRS signal)

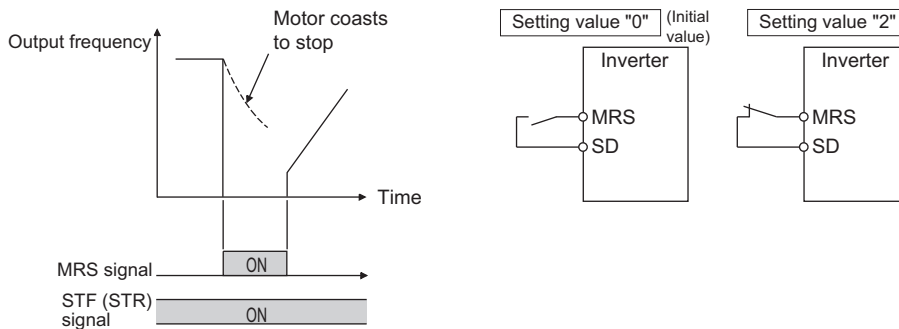

- When the Output stop (MRS) signal is turned ON while operating the inverter, the inverter output is instantaneously shut off.
- To input the MRS signal, set "24" in any parameter from **Pr.178 to Pr.182 and Pr.185 to Pr.189 (Input terminal function selection)** to assign the function.
- The response time of the MRS signal is within 2 ms
- The MRS signal is used in the following cases.

Application	Description
To stop the motor using a mechanical brake (e.g. electromagnetic brake)	The inverter output is shut off when the mechanical brake operates.
To provide interlock to disable the motor operation by the inverter	With the MRS signal ON, the motor cannot be driven by the inverter even if the start signal is input to the inverter.
To coast the motor to a stop	When the start signal is turned OFF, the inverter decelerates the motor to a stop in the preset deceleration time, but when the MRS signal is turned ON, the motor coasts to a stop.

◆ MRS signal logic inversion (Pr.17 = "2")

- When **Pr.17 = "2 or 3"**, the input specification of the MRS signal is changed to normally closed (NC contact). The inverter will shut off the output when the MRS signal is turned OFF (when the contact is opened).

◆ Assigning a different action for each MRS signal input via communication and external terminal (Pr.17 = "4 or 5")

- When Pr.17 = "4 or 5", the MRS signal input from an external terminal is normally closed (NC contact), and the MRS signal input from communication is normally open (NO contact). This function is useful to perform operation via communication while keeping the ON state of the MRS signal input from the external terminal.

External MRS	Communication MRS	Pr.17 setting		
		0, 1	2, 3	4, 5
OFF	OFF	Operation enabled	Output shutoff	Output shutoff
OFF	ON	Output shutoff	Output shutoff	Output shutoff
ON	OFF	Output shutoff	Output shutoff	Operation enabled
ON	ON	Output shutoff	Operation enabled	Output shutoff

◆ Operation when PU operation interlock enabled (Pr.79 = "7")

- When the X12 signal is not assigned to any input terminal while the PU operation interlock is enabled (Pr.79 = "7"), the MRS signal is used as the X12 signal. The logic for the MRS signal used as the X12 signal is changed by the Pr.17 setting.
- The operation when the PU operation interlock is enabled (Pr.79 = "7") is as follows.

Pr.17 setting	MRS signal	X12 signal	MRS function	X12 function
0, 1	Assigned	Not assigned	PU operation interlock (NO contact)	—
	Not assigned	Assigned	—	PU operation interlock (NO contact)
	Assigned	Assigned	Output shutoff (NO contact)	—
2 to 5	Assigned	Not assigned	PU operation interlock (NC contact)	—
	Not assigned	Assigned	—	PU operation interlock (NO contact)
	Assigned	Assigned	Output shutoff (NC contact)	—

NOTE

- When using an external terminal to input the MRS signal, the MRS signal shuts off the output in any of the operation modes.
- The MRS signal is valid regardless of whether it is input through the external terminal or via network, but when the MRS signal is used as the Inverter run enable (X10) signal, input the signal through the external terminal.
- When the terminal assignment is changed using Pr.178 to Pr.182 and Pr.185 to Pr.189 (Input terminal function selection), wiring may be mistaken due to different terminal name and signal contents, or may affect other functions. Set parameters after confirming the function of each terminal.

Parameters referred to

Pr.79 Operation mode selection [page 142](#)

Pr.178 to Pr.182 and Pr.185 to Pr.189 (Input terminal function selection) [page 252](#)

11.6 Selecting the condition to activate the Second function selection (RT) signal

The second function can be selected using the RT signal.

- Turning ON the Second function selection (RT) signal enables the second functions. To input the RT signal, set "3" in any parameter from **Pr.178 to Pr.182** and **Pr.185 to Pr.189 (Input terminal function selection)** to assign the function.
- The following are the examples of the applications of the second functions.
 - Switching between regular use and emergency use
 - Switching between heavy load and light load
 - Changing the acceleration/deceleration time by break point acceleration/deceleration
 - Switching characteristics of main motor and sub motor

Connection diagram example for the second function

Example of the second acceleration/deceleration time

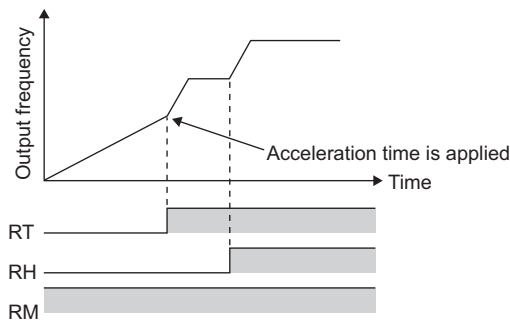
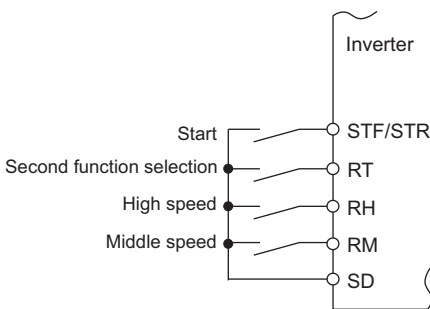

- When the RT signal is ON, second functions are selected. The following table shows the functions which can be changed to the second function.

Function	First function parameter number	Second function parameter number	Refer to page
Torque boost	Pr.0	Pr.46 ^{*2}	327
Base frequency	Pr.3	Pr.47 ^{*2}	329
Acceleration time	Pr.7	Pr.44	130
Deceleration time	Pr.8	Pr.44, Pr.45	130
Electronic thermal O/L relay	Pr.9	Pr.51 ^{*2}	166
Free thermal	Pr.600 to Pr.604	Pr.692 to Pr.696 ^{*2}	
Motor permissible load level	Pr.607	Pr.608 ^{*2}	
Stall prevention	Pr.22	Pr.48 ^{*2}	195
Applied motor (thermal characteristics only) ^{*1}	Pr.71	Pr.450 ^{*2}	261

*1 The motor to be used is selected by the **Pr.71** setting regardless of ON/OFF state of the RT signal (when **Pr.450** ≠ "9999").

*2 Disabled under PM sensorless vector control.

NOTE

- Changing the terminal assignment using **Pr.178 to Pr.182** and **Pr.185 to Pr.189 (Input terminal function selection)** may affect the other functions. Set parameters after confirming the function of each terminal.

Parameters referred to

Pr.178 to Pr.182 and Pr.185 to Pr.189 (Input terminal function selection) page 252

11.7 Start signal operation selection

Operation of the start signal (STF/STR) can be selected.

The stopping method (deceleration stop or coasting) at turn-OFF of the start signal can also be selected. (For the stop operation selection, refer to [page 338](#).)

Pr.	Name	Initial value	Setting range	Description	
				Start signal (STF/STR)	Stop operation ^{*1}
250 G106	Stop selection	9999	0 to 100 s	STF signal: Forward rotation start STR signal: Reverse rotation start	The motor coasts to a stop after a lapse of the setting time when the start signal is turned OFF.
			1000 to 1100 s ^{*2}	STF signal: Start signal STR signal: Forward/reverse rotation signal	The motor coasts to a stop after a lapse of the (Pr.250 - 1000) seconds when the start signal is turned OFF.
			9999	STF signal: Forward rotation start STR signal: Reverse rotation start	The motor is decelerated to a stop when the start signal is turned OFF.
			8888 ^{*2}	STF signal: Start signal STR signal: Forward/reverse rotation signal	

*1 For the stop operation selection, refer to [page 338](#).

*2 The start signal operation selection is available in External operation mode or when the start command source is External in the Network operation mode.

◆ 2-wire type (STF signal, STR signal)

- The following figure shows the 2-wire type connection.
- As an initial setting, the forward/reverse rotation signals (STF/STR) act as both start and stop signals. Either one turned ON will be enabled, and the operation will follow that signal. The motor will decelerate to a stop when both are turned OFF (or both are turned ON) during the operation.
- The frequency can be set by inputting 0 to 10 VDC between the speed setting input terminals 2 and 5, or with **Pr.4 to Pr.6 Multi-speed setting (high speed, middle speed, and low speed)**. (For the multi-speed operation, refer to [page 163](#).)
- By setting **Pr.250 = "1000 to 1100, 8888"**, the STF signal input becomes the start command and the STR signal input becomes the forward/reverse command.

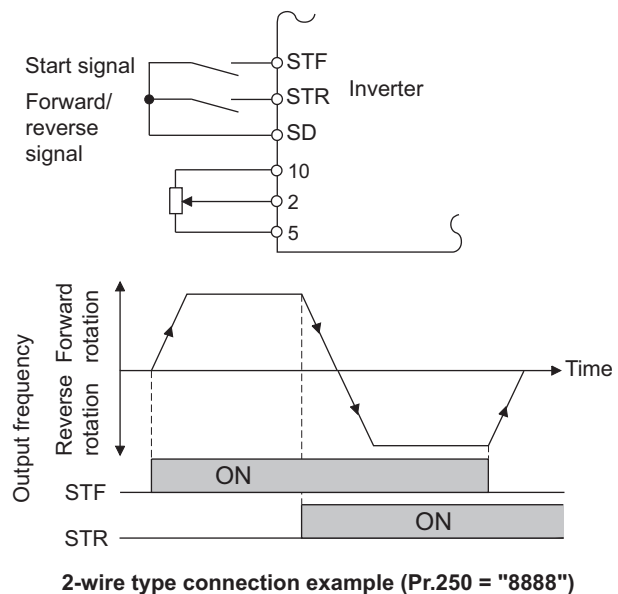
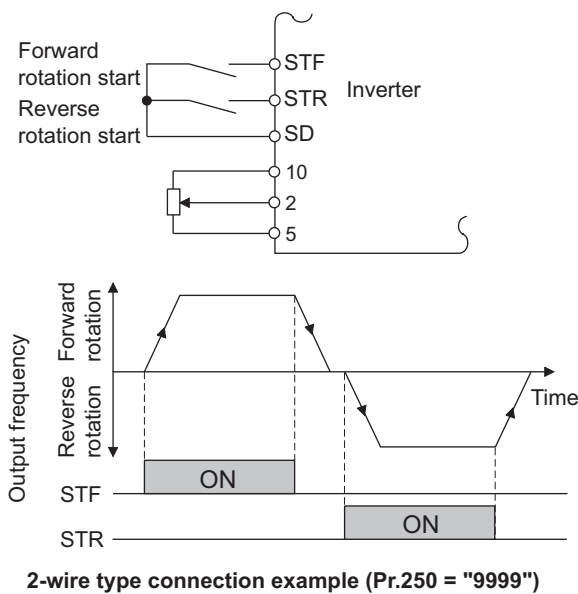

NOTE

- By setting **Pr.250** = "0 to 100, 1000 to 1100", the motor will coast to a stop when the start command is turned OFF. (Refer to [page 338](#).)
- The STF and STR signals are assigned to **Pr.178 STF terminal function selection** and **Pr.179 STR terminal function selection** in the initial status. The STF signal can be assigned to only **Pr.178**, and the STR signal can be assigned to only **Pr.179**.

◆ 3-wire type (STF signal, STR signal, STOP signal)

- The following figure shows the 3-wire type connection.
- The self-holding function is enabled when the STOP signal is turned ON. In such case, the forward/reverse signal is simply used as a start signal. (The STOP signal can be input via an external terminal only.)
- For the STOP signal, set "25" in any parameter from **Pr.178 to Pr.182 (Input terminal function selection)** to assign the function.
- Even if a start signal (STF or STR) is turned ON and then OFF, the start command remains valid and the motor operation continues. To change the rotation direction, turn the STR (STF) signal ON once and then OFF.
- In order to decelerate the motor to a stop, turn OFF the STOP signal once.

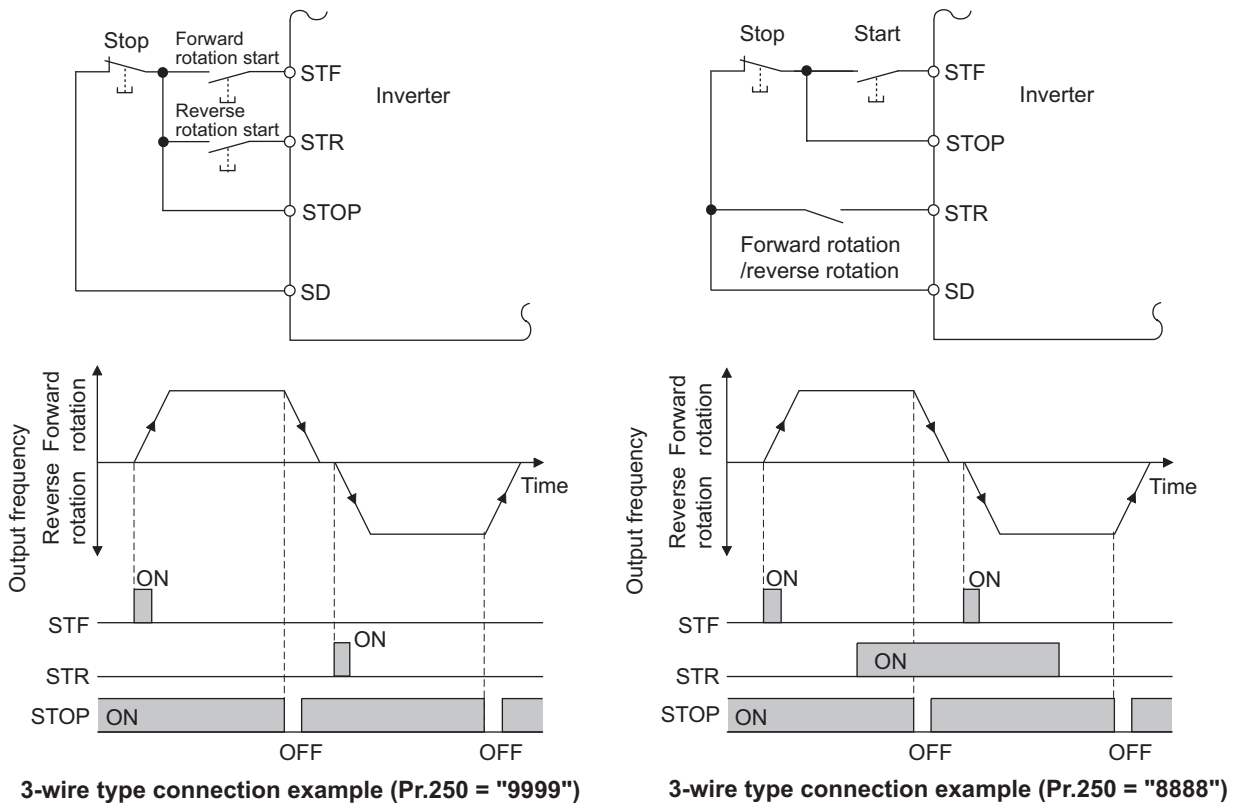

NOTE

- When the JOG operation is enabled by turning ON the JOG signal, the STOP signal will be disabled.
- Even when the output is stopped by turning ON the MRS signal, the self-holding function is not canceled.

◆ Start signal operation

STF	STR	Pr.250 setting and inverter condition	
		0 to 100 s, 9999	1000 to 1100 s, 8888
OFF	OFF	Stop	Stop
OFF	ON	Reverse rotation	
ON	OFF	Forward rotation	Forward rotation
ON	ON	Stop	Reverse rotation

« Parameters referred to »

Pr.4 to Pr.6 Multi-speed setting  [page 163](#)

Pr.178 to Pr.182 and Pr.185 to Pr.189 (Input terminal function selection)  [page 252](#)

12 (C) Motor Constant Parameters

Purpose	Parameter to set			Refer to page
To select the motor to be used	Applied motor	P.C100, P.C200	Pr.71, Pr.450	261
To maximize the performance of the induction motor	Offline auto tuning	P.C100 to P.C105, P.C110, P.C120 to P.C126, P.A711	Pr.9, Pr.71, Pr.80 to Pr.84, Pr.90 to Pr.94, Pr.96, Pr.298, Pr.859	266
To maximize the performance of the PM motor	PM motor offline auto tuning	P.C100 to P.C108, P.C110, P.C120, P.C122, P.C123, P.C126, P.C130 to P.C133, P.C135, P.C150, P.C182, P.C185	Pr.9, Pr.71, Pr.80, Pr.81, Pr.83, Pr.84, Pr.90, Pr.92, Pr.93, Pr.96, Pr.702, Pr.706, Pr.707, Pr.711, Pr.712, Pr.717, Pr.721, Pr.724, Pr.725, Pr.859, Pr.1002, Pr.1412	274

12.1 Applied motor

By setting the applied motor type, the thermal characteristic appropriate for the motor can be selected.

When using a constant-torque or PM motor, the electronic thermal O/L relay function is set according to the motor.

When the Advanced magnetic flux vector control or PM sensorless vector control is selected, the motor constant necessary for control (for SF-PR, SF-JR, SF-HR, SF-JRCA, SF-HRCA, or EM-A) is also selected at the same time.

Pr.	Name	Initial value	Setting range	Description
71 C100	Applied motor	0	0, 3, 5, 6, 10, 13, 15, 16, 20, 23, 40, 43, 50, 53, 70, 73, 1140, 8090, 8093, 9090, 9093	By selecting a motor, the thermal characteristic and motor constant of each motor are set.
450 C200	Second applied motor	9999	0, 10	Set this parameter when using the second motor (the same specifications as Pr.71).
			9999	The function is disabled.

◆ Setting the applied motor

- Refer to the following list and set the parameters according to the applied motor.

Pr.71	Pr.450	Motor	Motor constant value range when performing offline auto tuning (increment)	Electronic thermal O/L relay function			
				Standard	Constant-torque	PM	
0 (Pr.71 initial value)		Standard motor (such as SF-JR)	Pr.82, Pr.859 • 0 to 500 A, 9999 (0.01 A) Pr.90, Pr.91 • 0 to 50 Ω, 9999 (0.001 Ω) Pr.92, Pr.93 (Induction motor) • 0 to 6000 mH, 9999 (0.1 mH) Pr.92, Pr.93 (PM motor) • 0 to 650 mH, 9999 (0.01 mH) Pr.94 • 0% to 100%, 9999 (0.1%) Pr.706 • 0 to 5000 mV (rad/s), 9999 (0.1 mV (rad/s))	○			
10		Constant-torque motor (such as SF-JRCA)			○		
20	—	Mitsubishi Electric standard efficiency motor (SF-JR 4P 1.5 kW or lower)			○		
40	—	Mitsubishi Electric high-efficiency motor SF-HR			○		
50	—	Mitsubishi Electric constant-torque motor SF-HRCA			○		
70	—	Mitsubishi Electric high-performance energy-saving motor SF-PR			○		
1140 *1	—	Mitsubishi Electric PM motor EM-A				○	
8090	—	IPM motor			○		
9090	—	PM motor			○		
3	—	Standard motor (such as SF-JR)		Pr.82, Pr.859, Pr.90 to Pr.94, Pr.706 • Internal data value 0 to 65534, 9999 (1)	○		
13	—	Constant-torque motor (such as SF-JRCA)			○		
23	—	Mitsubishi Electric standard efficiency motor (SF-JR 4P 1.5 kW or lower)			○		
43	—	Mitsubishi Electric high-efficiency motor SF-HR			○		
53	—	Mitsubishi Electric constant-torque motor SF-HRCA			○		
73	—	Mitsubishi Electric high-performance energy-saving motor SF-PR			○		
8093	—	IPM motor			○		
9093	—	PM motor			○		
5	—	Standard motor	Wye connection		○		
15	—	Constant-torque motor				○	
6	—	Standard motor	Delta connection	○			
16	—	Constant-torque motor			○		
—	9999 (initial value)	No second applied motor					

*1 The value is valid in any of the following conditions. Under other conditions, "SE" (Incorrect parameter setting) is displayed when the start command is turned ON.

The FR-D820-11K-450 or lower is used and **Pr.80** ≤ 7.5 kW.

The FR-D840-11K-230 or lower is used and **Pr.80** = 0.4 to 7.5 kW.

FR-D820S-2.2K-100 or lower is used and **Pr.80** ≤ 2.2 kW.

FR-D810W-0.75K-042 or lower is used and **Pr.80** ≤ 0.75 kW.

NOTE

- Regardless of the **Pr.71** setting, offline auto tuning can be performed according to **Pr.96 Auto tuning setting/status**. (Refer to [page 266](#) for offline auto tuning.)

◆ Changing motor thermal characteristics (RT signal, Pr.450)

- To change the motor thermal characteristics, use **Pr.450 Second applied motor**.
- The setting value "9999 (initial value)" disables the second motor.
- **Pr.450** is enabled when the RT signal is ON. To input the RT signal, set "3" in any parameter from **Pr.178 to Pr.182 and Pr.185 to Pr.189 (Input terminal function selection)** to assign the function.
- The motor to be used is selected by the **Pr.71** setting regardless of ON/OFF state of the RT signal

NOTE

- The RT signal is the Second function selection signal. The RT signal also enables other second functions. (Refer to [page 257](#).)
- Changing the terminal assignment using **Pr.178 to Pr.182 and Pr.185 to Pr.189 (Input terminal function selection)** may affect the other functions. Set parameters after confirming the function of each terminal.
- The second motor setting is disabled under PM sensorless vector control. (Operation when **Pr.450** = "9999" is performed.)

◆ Automatic change of torque boost for the SF-PR motor

- When the SF-PR motor is selected (**Pr.71** = "70 or 73"), the **Pr.0 Torque boost** setting is automatically changed to enable output of the 6 Hz 150% torque under V/F control by setting **Pr.81 Number of motor poles** according to the number of the SF-PR motor poles.

NOTE

- When selecting the automatic change of torque boost for the SF-PR motor, set **Pr.14 Load pattern selection** = "0 (initial value)".
- When the **Pr.0** setting is changed from its initial value, the automatic change is not performed.

◆ Automatic change of Pr.0 Torque boost and Pr.12 DC injection brake operation voltage

- When initial values are set in Pr.0 and Pr.12, the Pr.0 and Pr.12 settings are automatically changed to the values in the following table by changing the Pr.71 setting.

Inverter		Pr.0 value (%) after automatic change											
FR-D820-[]	FR-D840-[]	Standard motor ^{*1}		Constant-torque motor ^{*2}		SF-PR ^{*3}							
		SLD	ND	SLD	ND	Pr.81 ≠ "2, 4, 6"		Pr.81 = "2"		Pr.81 = "4"		Pr.81 = "6"	
						SLD	ND	SLD	ND	SLD	ND	SLD	ND
0.1K-008	—	6	6	6	6	5.5	4	8.6	4	8.6	4	8.6	4
0.2K-014	—	6	6	6	6	5	5.5	8	8.6	6.5	8.6	7.5	8.6
0.4K-025	0.4K-012	6	6	6	6	4	5	7.4	8	6	6.5	6.4	7.5
0.75K-042	0.75K-022	4	6	4	6	3	4	5.8	7.4	5	6	3.7	6.4
1.5K-070	1.5K-037	4	4	4	4	2.5	3	6	5.8	4.5	5	3.3	3.7
2.2K-100	2.2K-050	4	4	4	4	2.5	2.5	6.4	6	4.5	4.5	4.2	3.3
3.7K-165	3.7K-081	3	4	2	4	2	2.5	4.5	6.4	3.7	4.5	3.3	4.2
5.5K-238	5.5K-120	3	3	2	2	2	2	4.4	4.5	4.5	3.7	3.8	3.3
7.5K-318	7.5K-163	2	3	2	2	1.5	2	3.5	4.4	3.3	4.5	3.5	3.8
11K-450	11K-230	2	2	2	2	1.5	1.5	4.5	3.5	3	3.3	3.5	3.5
15K-580	15K-295	2	2	2	2	1.5	1.5	4	4.5	3.2	3	3	3.5

Inverter		Pr.0 value (%) after automatic change											
FR-D820S-[]	FR-D810W-[]	Standard motor ^{*1}		Constant-torque motor ^{*2}		SF-PR ^{*3}							
		ND	ND	ND	ND	Pr.81 ≠ "2, 4, 6"		Pr.81 = "2"		Pr.81 = "4"		Pr.81 = "6"	
						ND	ND	ND	ND	ND	ND	ND	ND
0.1K-008	0.1K-008	6		6		4		4		4		4	
0.2K-014	0.2K-014	6		6		5.5		8.6		8.6		8.6	
0.4K-025	0.4K-025	6		6		5		8		6.5		7.5	
0.75K-042	0.75K-042	6		6		4		7.4		6		6.4	
1.5K-070	—	4		4		3		5.8		5		3.7	
2.2K-100	—	4		4		2.5		6		4.5		3.3	

Inverter		Pr.12 value (%) after automatic change					
FR-D820-[]	FR-D840-[]	Standard motor ^{*1}		Constant-torque motor ^{*2}		SF-PR ^{*3}	
		SLD	ND	SLD	ND	SLD	ND
0.1K-008	—	6	6	6	6	5.5	4
0.2K-014	—	4	6	4	6	5	5.5
0.4K-025	0.4K-012	4	4	4	4	4	5
0.75K-042	0.75K-022	4	4	4	4	2.5	4
1.5K-070	1.5K-037	4	4	4	4	2.5	2.5
2.2K-100	2.2K-050	4	4	4	4	2.5	2.5
3.7K-165	3.7K-081	4	4	2	4	2	2.5
5.5K-238	5.5K-120	4	4	2	2	2	2
7.5K-318	7.5K-163	2	4	2	2	1.5	2
11K-450	11K-230	2	2	2	2	1.5	1.5
15K-580	15K-295	2	2	2	2	1.5	1.5

Inverter		Pr.12 value (%) after automatic change					
FR-D820S-[]	FR-D810W-[]	Standard motor ^{*1}		Constant-torque motor ^{*2}		SF-PR ^{*3}	
		ND		ND		ND	
0.1K-008	0.1K-008	6		6		4	
0.2K-014	0.2K-014	6		6		5.5	
0.4K-025	0.4K-025	4		4		5	
0.75K-042	0.75K-042	4		4		4	
1.5K-070	—	4		4		2.5	
2.2K-100	—	4		4		2.5	

*1 Pr.71 = "0, 3, 5, 6, 20, 23, 40, or 43" (standard motor)

*2 Pr.71 = "10, 13, 15, 16, 50, or 53" (constant-torque motor)

*3 Pr.71 = "70 or 73" (SF-PR)

NOTE

- When the **Pr.0** and **Pr.12** settings are changed from their initial values, the automatic change is not performed.
- When the SF-PR motor is selected (**Pr.71** = "70 or 73"), the output current may become large due to a small load by setting **Pr.81 Number of motor poles** according to the number of the SF-PR motor poles.
- When the SF-PR motor is used, the output current tends to increase compared with the case where the SF-JR or SF-HR motor is used. Depending on the load conditions, the output current may increase even though the torque boost value has been automatically changed. When the protective function such as the electronic thermal O/L relay (E.THT, E.THM) or stall prevention (OL, E.OLT) is activated, adjust **Pr.0 Torque boost** according to the load.

CAUTION

- Make sure to set this parameter correctly according to the motor used. Incorrect setting may cause the motor and the inverter to overheat and burn.

Parameters referred to

Pr.0 Torque boost  [page 327](#)

Pr.12 DC injection brake operation voltage  [page 335](#)

Pr.14 Load pattern selection  [page 331](#)

Pr.96 Auto tuning setting/status  [page 266](#)

Pr.178 to Pr.182 and Pr.185 to Pr.189 (Input terminal function selection)  [page 252](#)

12.2 Offline auto tuning

Magnetic flux

The offline auto tuning enables the optimal operation of a motor.

- Under Advanced magnetic flux vector control, automatic measurement of motor constants enables optimal operation of motors even when motor constants vary, when a motor of another company is used, or when the wiring distance is long.

For the offline auto tuning for a PM motor, refer to [page 274](#).

Pr.	Name	Initial value	Setting range	Description
71 C100	Applied motor	0	0, 3, 5, 6, 10, 13, 15, 16, 20, 23, 40, 43, 50, 53, 70, 73, 1140, 8090, 8093, 9090, 9093	By selecting a motor, the thermal characteristic and motor constant of each motor are set.
80 C101	Motor capacity	9999	0.1 to 18.5 kW 9999	Set the applied motor capacity. No motor capacity setting
81 C102	Number of motor poles	9999	2, 4, 6, 8, 10, 12 9999	Set the number of motor poles. No number of motor poles setting
9 C103	Electronic thermal O/L relay	Inverter rated current ^{*1}	0 to 500 A	Set the rated motor current.
83 C104	Rated motor voltage	200/400 V ^{*2}	0 to 1000 V	Set the rated motor voltage (V).
84 C105	Rated motor frequency	9999	10 to 400 Hz 9999	Set the rated motor frequency (Hz). The setting value of Pr.3 Base frequency is used.
96 C110	Auto tuning setting/status	0	0 1 11	No offline auto tuning Offline auto tuning is performed without the motor rotating. Offline auto tuning is performed without the motor rotating (under V/F control). (Refer to page 314 .)
90 C120	Motor constant (R1)	9999	0 to 50 Ω, 9999 ^{*3}	Tuning data (The value measured by offline auto tuning is automatically set.) 9999: The constant value of Mitsubishi Electric motor (SF-PR, SF-JR, SF-HR, SF-JRCA, or SF-HRCA) is used.
91 C121	Motor constant (R2)	9999	0 to 50 Ω, 9999 ^{*3}	
92 C122	Motor constant (L1)/d-axis inductance (Ld)	9999	0 to 6000 mH, 9999 ^{*3}	
93 C123	Motor constant (L2)/q-axis inductance (Lq)	9999	0 to 6000 mH, 9999 ^{*3}	
94 C124	Motor constant (X)	9999	0% to 100%, 9999 ^{*3}	
82 C125	Motor excitation current	9999	0 to 500 A, 9999 ^{*3}	
859 C126	Torque current/ Rated PM motor current	9999	0 to 500 A, 9999 ^{*3}	
298 A711	Frequency search gain	9999	0 to 32767 9999	The offline auto tuning automatically sets the gain required for the frequency search. The constant value of Mitsubishi Electric motor (SF-PR, SF-JR, SF-HR, SF-JRCA, or SF-HRCA) is used.

*1 The initial value for the FR-D820-0.75K-042 or lower, the FR-D840-0.75K-022 or lower, FR-D820S-0.75K-042 or lower, the FR-D810W-0.75K-042 or lower is set to the 85% of the inverter rated current.

*2 The initial value differs according to the voltage class (100/200 V, 400 V).

*3 The setting range and unit change according to the **Pr.71** setting.

- The setting is valid under Advanced magnetic flux vector control.
- By using the offline auto tuning function, the optimum operation characteristics are obtained for a motor other than Mitsubishi Electric standard efficiency motors (SF-JR 0.2 kW or higher), high-efficiency motors (SF-HR 0.2 kW or higher), Mitsubishi Electric constant-torque motors (SF-JRCA 4P, SF-HRCA 0.2 kW to 7.5 kW), or Mitsubishi Electric high-performance energy-saving motor (SF-PR), such as an induction motor of other manufacturers or SF-JRC, or with a long wiring length (exceeding 15 m as a reference).
- Tuning is enabled even when a load is connected to the motor.
- Reading/writing of the motor constants tuned by offline auto tuning are enabled.
- The offline auto tuning status can be monitored on the operation panel or the parameter unit.

◆ Before performing offline auto tuning

Check the following points before performing offline auto tuning:

- Check that a value other than "9999" is set in **Pr.80** and **Pr.81**, and Advanced magnetic flux vector control is selected (with **Pr.800**). (Refer to [page 72](#).)
- Check that a motor is connected. (Check that the motor is not rotated by an external force during tuning.)
- Select a motor with the rated current equal to or less than the inverter rated current.
If a motor with substantially low rated current compared with the inverter rated current is used, speed accuracy may deteriorate due to torque ripples, etc. Set the rated motor current to about 40% or higher of the inverter rated current. (For details on the inverter rated current, refer to the inverter rated specifications in the Instruction Manual (Connection).)
- Tuning is not available for a high-slip motor, high-speed motor, or special motor.
- The maximum frequency is 400 Hz.
- Tuning is enabled even when a load is connected to the motor. The motor may run slightly. Fix the motor securely with a mechanical brake, or before tuning, make sure that it is safe even if the motor rotates. (Caution is required especially in vertical lift applications.) Note that even if the motor runs slightly, tuning performance is unaffected.
- Offline auto tuning is not performed correctly when the surge voltage suppression filter (FR-ASF-H/FR-BMF-H) is inserted between the inverter and motor. Be sure to remove it before performing tuning.

◆ Settings

- To perform tuning, set the following parameters about the motor.

Pr.	Name	Initial value	Description
80	Motor capacity	9999 (V/F control)	Set the motor capacity (kW).
81	Number of motor poles	9999 (V/F control)	Set the number of motor poles (2 to 12).
800	Control method selection	40	Set "20" (Advanced magnetic flux vector control).
9	Electronic thermal O/L relay	Inverter rated current	Set the rated motor current (A).
83	Rated motor voltage	200/400 V ^{*1}	Set the rated motor voltage (V) printed on the motor's rating plate.
84	Rated motor frequency	9999	Set the rated motor frequency (Hz). When the setting is "9999", the Pr.3 Base frequency setting is used.
71	Applied motor	0 (standard motor)	Set this parameter according to the motor. ^{*2} Three types of motor constant setting ranges, units and tuning data can be stored according to settings.
96	Auto tuning setting/status	0	Set "1". 1: Tuning is performed without the motor rotating. (Excitation noise occurs at this point.)

*1 The initial value differs according to the voltage class (100/200 V, 400 V).

*2 Set **Pr.71 Applied motor** according to the motor to be used and the motor constant setting range. According to the **Pr.71** setting, the range of the motor constant parameter setting values and units can be changed. (For other setting values of **Pr.71**, refer to [page 261](#).)

Motor		Pr.71 setting		
		Motor constant parameter mH, %, and A unit setting	Motor constant parameter internal data setting	Motor constant parameter Ω, mΩ, and A unit setting
Mitsubishi Electric high-performance energy-saving motor	SF-PR	70	73	—
Mitsubishi Electric standard efficiency motor Mitsubishi Electric high-efficiency motor	SF-JR	0 (initial value)	3	—
	SF-JR 4P 1.5 kW or lower	20	23	—
	SF-HR	40	43	—
	Others	0 (initial value)	3	—
Mitsubishi Electric constant-torque motor	SF-JRCA 4P	10	13	—
	SF-HRCA	50	53	—
	Others (SF-JRC, etc.)	10	13	—
Other manufacturer's standard motor	—	0 (initial value)	3	5 (wye connection motor) 6 (delta connection motor)
Other manufacturer's constant-torque motor	—	10	13	15 (wye connection motor) 16 (delta connection motor)

NOTE

- When **Pr.11 DC injection brake operation time** = "0" or **Pr.12 DC injection brake operation voltage** = "0", offline auto tuning is performed at the initial setting of **Pr.11** or **Pr.12**.
- If "wye connection" or "delta connection" is incorrectly selected in **Pr.71**, Advanced magnetic flux vector control is not performed properly.

◆ Performing tuning

Point



- Before performing tuning, check the monitor display of the operation panel or parameter unit if the inverter is in the state ready for tuning. The motor starts by turning ON the start command while tuning is unavailable.

- In the PU operation mode, press the RUN key on the operation panel or the FWD/REV key on the parameter unit. In the External operation, turn ON the start command (STF signal or STR signal). Tuning starts.

NOTE

- Satisfy the required inverter start conditions to start offline auto tuning. For example, stop the input of the MRS signal.
- To force tuning to end, use the MRS or RES signal or the STOP/RESET key on the PU. (Turning OFF the start signal (STF signal or STR signal) also ends tuning.)
- During offline auto tuning, only the following I/O signals are valid (initial value).
Input terminals <effective signals>: MRS, RES, STF, STR, S1, and S2
Output terminals: RUN, AM, ABC, and So (SO)
- When the rotation speed and the output frequency are selected for terminal AM, the progress status of offline auto tuning is output in 15 steps from AM.
- Do not perform ON/OFF switching of the Second function selection (RT) signal during offline auto tuning. Auto tuning will not be performed properly.
- Since the Inverter running (RUN) signal turns ON when tuning is started, pay close attention especially when a sequence which releases a mechanical brake by the RUN signal has been designed.
- When executing offline auto tuning, input the operation command after switching ON the main circuit power (R/L1, S/L2, T/L3) of the inverter.
- While **Pr.79 Operation mode selection** = "7", turn ON the PU operation external interlock (X12) signal for tuning in the PU operation mode.

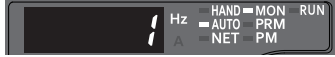
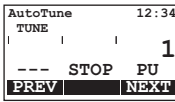
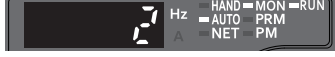
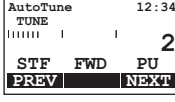
- The tuning status (**Pr.96** setting value) is displayed on the operation panel.

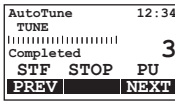
Tuning status	Operation panel indication	LCD operation panel (FR-LU08) display
(1) Setting		
(2) During tuning		
(3) Normal completion		

- Note: Offline auto tuning time (with the initial setting)

Offline auto tuning setting	Time
Pr.96 = "1"	About 25 to 100 s. (The time depends on the inverter capacity and motor type.)

- When offline auto tuning ends, press the STOP/RESET key on the PU during PU operation. In the External operation mode, turn OFF the start signal (STF signal or STR signal). This operation resets the offline auto tuning, and the monitor display of the operation panel returns to normal. (Without this operation, next operation cannot be started.)

NOTE

- The motor constants measured once during offline auto tuning are stored as parameters and their data are held until offline auto tuning is performed again. However, the tuning data is cleared when performing All parameter clear.
- Changing **Pr.71** after tuning completion will change the motor constant. For example, if "3" is set in **Pr.71** after tuning is performed with **Pr.71** = "0", the tuning data becomes invalid. To use the tuned data, set "0" again in **Pr.71**.

- If offline auto tuning has ended in error (refer to the following table), motor constants are not set. Perform an inverter reset and restart tuning.

Error display	Error cause	Countermeasures
8	Forced end	Set "1" in Pr.96 and retry.
9	Inverter protective function operation	Make the setting again.
91	The current limit (stall prevention) function is activated.	Set the acceleration/deceleration time longer. Set Pr.156 Stall prevention operation selection = "1".
92	The converter output voltage fell to 75% of the rated voltage.	Check for the power supply voltage fluctuation. Check the Pr.83 Rated motor voltage setting.
93	Calculation error. The motor is not connected.	Check the Pr.83 and Pr.84 settings. Check the motor wiring and make the setting again.

- When tuning is ended forcibly by pressing the STOP/RESET key or turning OFF the start signal (STF or STR) during tuning, offline tuning does not end properly. (The motor constants have not been set.)
Perform an inverter reset and perform tuning again.
- When the rated power supply of the motor is 200/220 V (400/440 V) 60 Hz, set the rated motor current multiplied by 1.1 in **Pr.9 Electronic thermal O/L relay** after tuning is complete.
- For a motor with a PTC thermistor, thermal protector, or some other thermal detector, set "0" (motor overheat protection by inverter invalid) in **Pr.9** to protect the motor from overheating.

NOTE

- An instantaneous power failure occurring during tuning will result in a tuning error. After power is restored, the inverter starts normal operation. Therefore, when the STF (STR) signal is ON, the motor starts forward (reverse) rotation.
- Any fault occurring during tuning is handled as in the normal operation. However, if the retry function is set, no retry is performed.
- The set frequency monitor displayed during the offline auto tuning is 0 Hz.

CAUTION

- Note that the motor may start running suddenly.
- For performing offline auto tuning with the motor rotating in vertical lift applications, etc., caution is required to avoid falling due to insufficient torque.

◆ Changing the motor constants

- The motor constants can be set directly when the motor constants are known in advance, or by using the data measured during offline auto tuning.
- According to the **Pr.71** setting, the range of the motor constant parameter setting values and units can be changed. The changed settings are stored in the EEPROM as the motor constant parameters.

◆ Changing the motor constants (when setting the Pr.92 and Pr.93 motor constants in units of mH)

- Set **Pr.71** as follows.

Motor		Pr.71 setting
Mitsubishi Electric high-performance energy-saving motor	SF-PR	70
Mitsubishi Electric standard efficiency motor	SF-JR	0 (initial value)
Mitsubishi Electric high-efficiency motor	SF-JR 4P 1.5 kW or lower	20
	SF-HR	40
Mitsubishi Electric constant-torque motor	SF-JRCA 4P	10
	SF-HRCA	50

- Use the following formula to find the **Pr.94** setting value and set a desired value as the motor constant parameter.

$$\text{The setting value of Pr.94} = \left(1 - \frac{M^2}{L1 \times L2} \right) \times 100(\%)$$

Equivalent circuit diagram of the motor

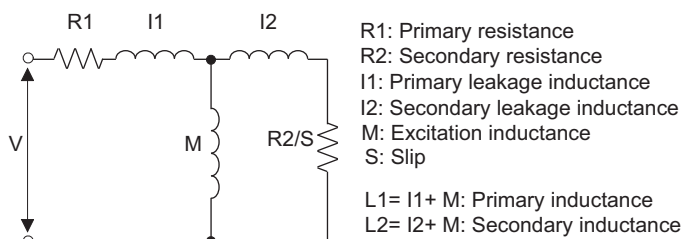

Pr.	Name	Setting range	Setting increments	Initial value
82	Motor excitation current (no load current)	0 to 500 A, 9999	0.01 A	9999
90	Motor constant (R1)	0 to 50 Ω, 9999	0.001 Ω	
91	Motor constant (R2)	0 to 50 Ω, 9999	0.001 Ω	
92	Motor constant (L1)/d-axis inductance (Ld)	0 to 6000 mH, 9999	0.1 mH	
93	Motor constant (L2)/q-axis inductance (Lq)	0 to 6000 mH, 9999	0.1 mH	
94	Motor constant (X)	0% to 100%, 9999	0.1%	
859	Torque current/Rated PM motor current	0 to 500 A, 9999	0.01 A	
298	Frequency search gain	0 to 32767, 9999	1	

NOTE

- If "9999" is set in the motor constant parameters, tuning data will be invalid and the constant values for Mitsubishi Electric motors (SF-PR, SF-JR, SF-HR, SF-JRCA, SF-HRCA, and so on) are used.

◆ Changing the motor constants (when setting motor constants in the internal data of the inverter)

- Set **Pr.71** as follows.

Motor		Pr.71 setting
Mitsubishi Electric high-performance energy-saving motor	SF-PR	73
Mitsubishi Electric standard efficiency motor Mitsubishi Electric high-efficiency motor	SF-JR	3
	SF-JR 4P 1.5 kW or lower	23
	SF-HR	43
	Others	3
Mitsubishi Electric constant-torque motor	SF-JRCA 4P	13
	SF-HRCA	53
	Others (SF-JRC, etc.)	13
Other manufacturer's standard motor	—	3
Other manufacturer's constant-torque motor	—	13

- Set desired values as the motor constant parameters.

Pr.	Name	Setting range	Setting increments	Initial value
82	Motor excitation current	0 to **, 9999	1	9999
90	Motor constant (R1)			
91	Motor constant (R2)			
92	Motor constant (L1)/d-axis inductance (Ld)			
93	Motor constant (L2)/q-axis inductance (Lq)			
94	Motor constant (X)			
859	Torque current/Rated PM motor current			
298	Frequency search gain	0 to 32767, 9999	1	

NOTE

- As the motor constants measured in the offline auto tuning have been converted into internal data (***), refer to the following setting example when making setting. (The value displayed has been converted into a value for internal use. Therefore, simple addition of a value to the displayed value does not bring the desired effect.)
Setting example: To slightly increase the **Pr.90** value (5%)
When "2516" is displayed for **Pr.90**, set 2642 ($2516 \times 1.05 = 2641.8$) in **Pr.90**.
- If "9999" is set in the motor constant parameters, tuning data will be invalid and the constant values for Mitsubishi Electric motors (SF-PR, SF-JR, SF-HR, SF-JRCA, SF-HRCA, and so on) are used.

◆ Changing the motor constants (when setting the Pr.92, Pr.93, and Pr.94 motor constants in units of Ω)

- Set Pr.71 as follows.

Applied motor	Pr.71 setting	
	Wye connection motor	Delta connection motor
Standard motor	5	6
Constant-torque motor	15	16

- Set desired values as the motor constant parameters.

I_q = torque current, I_{100} = rated current, I_0 = no load current

$$I_q = \sqrt{I_{100}^2 - I_0^2}$$

Pr.	Name	Setting range	Setting increments	Initial value
82	Motor excitation current (no load current)	0 to 500 A, 9999	0.01 A	9999
90	Motor constant (r1)	0 to 50 Ω , 9999	0.001 Ω	
91	Motor constant (r2)	0 to 50 Ω , 9999	0.001 Ω	
92	Motor constant (x1)	0 to 50 Ω , 9999	0.001 Ω	
93	Motor constant (x2)	0 to 50 Ω , 9999	0.001 Ω	
94	Motor constant (xm)	0 to 500 Ω , 9999	0.01 Ω	
859	Torque current/Rated PM motor current	0 to 500 A, 9999	0.01 A	
298	Frequency search gain	0 to 32767, 9999	1	

NOTE

- If "wye connection" or "delta connection" is incorrectly selected in **Pr.71**, Advanced magnetic flux vector control is not performed properly.
- If "9999" is set in the motor constant parameters, tuning data will be invalid and the constant values for Mitsubishi Electric motors (SF-PR, SF-JR, SF-HR, SF-JRCA, SF-HRCA, and so on) are used.

Parameters referred to

Pr.1 Maximum frequency [page 191](#)

Pr.9 Electronic thermal O/L relay [page 166](#)

Pr.71 Applied motor [page 261](#)

Pr.156 Stall prevention operation selection [page 195](#)

Pr.800 Control method selection [page 72](#)

12.3 Offline auto tuning for a PM motor

PM

The offline auto tuning enables the optimal operation of a PM motor.

- Automatic measurement of the motor constant required for PM sensorless vector control operation enables optimal operation of motors even when the motor constant varies or when the wiring distance is long.
- Tuning may be disabled depending on the motor characteristics.

For the offline auto tuning under Advanced magnetic flux vector control, refer to [page 266](#).

Pr.	Name	Initial value	Setting range	Description
71 C100	Applied motor	0	0, 3, 5, 6, 10, 13, 15, 16, 20, 23, 40, 43, 50, 53, 70, 73, 1140 ^{*5} , 8090, 8093, 9090, 9093	By selecting a motor, the thermal characteristic and motor constant of each motor are set.
80 C101	Motor capacity	9999	0.1 to 18.5 kW 9999	Set the applied motor capacity. No motor capacity setting
81 C102	Number of motor poles	9999	2, 4, 6, 8, 10, 12 9999	Set the number of motor poles. No number of motor poles setting
9 C103	Electronic thermal O/L relay	Inverter rated current ^{*1}	0 to 500 A	Set the rated motor current.
83 C104	Rated motor voltage	200/ 400 V ^{*2}	0 to 1000 V	Set the rated motor voltage (V).
84 C105	Rated motor frequency	9999	10 to 400 Hz 9999	Set the rated motor frequency (Hz). Inverter internal data is used.
702 C106	Maximum motor frequency	9999	0 to 400 Hz 9999	Set the permissible speed (frequency) of the motor. The Pr.84 setting is used.
707 C107	Motor inertia (integer)	9999	10 to 999, 9999	Set the motor inertia. 9999: Inverter internal data is used.
724 C108	Motor inertia (exponent)	9999	0 to 7, 9999	
96 C110	Auto tuning setting/status	0	0 1 ^{*4} 11	No offline auto tuning Offline auto tuning is performed without the motor rotating (when driving a motor other than the EM-A). Offline auto tuning is performed without the motor rotating.
90 C120	Motor constant (R1)	9999	0 to 50 Ω, 9999 ^{*3}	Tuning data (The value measured by offline auto tuning is automatically set.)
92 C122	Motor constant (L1)/d-axis inductance (Ld)	9999	0 to 500 mH, 9999 ^{*3}	9999: Inverter internal data is used.
93 C123	Motor constant (L2)/q-axis inductance (Lq)	9999	0 to 500 mH, 9999 ^{*3}	
859 C126	Torque current/Rated PM motor current	9999	0 to 500 A, 9999 ^{*3}	
706 C130	Motor induced voltage constant (phi f)	9999	0 to 5000 mV (rad/s) ^{*3} 9999	Set this parameter according to the PM motor specifications. The value calculated from the parameter setting for motor constant is used.
1412 C135	Motor induced voltage constant (phi f) exponent	9999	0 to 2 9999	Set the exponent n when the induced voltage constant phi f (Pr.706) is multiplied by 10 ⁿ . No exponent setting
711 C131	Motor Ld decay ratio	9999	0% to 100%, 9999	Tuning data (The value measured by offline auto tuning is automatically set.)
712 C132	Motor Lq decay ratio	9999	0% to 100%, 9999	9999: Inverter internal data is used.
717 C182	Starting resistance tuning compensation coefficient	9999	0% to 200%, 9999	
721 C185	Starting magnetic pole position detection pulse width	9999	0 to 6000 μs, 9999	

Pr.	Name	Initial value	Setting range	Description
725 C133	Motor protection current level	9999	100% to 500%	Set the maximum current (OCT) level of the motor.
			9999	When the EM-A is selected: EM-A constant is used. When a PM motor other than the EM-A is selected: 200% is used.
1002 C150	Lq tuning target current adjustment coefficient	9999	50% to 150%	Adjust the target current during tuning.
			9999	100%

*1 The initial value for the FR-D820-0.75K-042 or lower, the FR-D840-0.75K-022 or lower, FR-D820S-0.75K-042 or lower, the FR-D810W-0.75K-042 or lower is set to the 85% of the inverter rated current.

*2 The initial value differs according to the voltage class (100/200 V, 400 V).

*3 The setting range and unit change according to the **Pr.71** setting.

*4 When the EM-A motor is used, the offline auto tuning cannot be performed.

*5 The value is valid in any of the following conditions. Under other conditions, "SE" (Incorrect parameter setting) is displayed when the start command is turned ON.

The FR-D820-11K-450 or lower is used and **Pr.80** ≤ 7.5 kW.

The FR-D840-11K-230 or lower is used and **Pr.80** = 0.4 to 7.5 kW

FR-D820S-2.2K-100 or lower is used and **Pr.80** ≤ 2.2 kW.

FR-D810W-0.75K-042 or lower is used and **Pr.80** ≤ 0.75 kW.

Point

- The settings are valid under PM sensorless vector control.
- The offline auto tuning enables the operation with IPM motors and PM motors. (When a PM motor other than the EM-A is used, always perform offline auto tuning.)
- Tuning is not available for S-PM geared motors (GV-S series).
- Even when the EM-A motor is used, if motor wiring is changed after offline auto tuning, perform tuning again.
- Tuning is enabled even when a load is connected to the motor.
- Reading/writing of the motor constants tuned by offline auto tuning are enabled.
- The offline auto tuning status can be monitored on the operation panel or the parameter unit.

◆ Before performing offline auto tuning

Check the following points before performing offline auto tuning:

- Check that PM sensorless vector control is selected. (Refer to [page 72](#).)
- Check that a motor is connected. (Check that the motor is not rotated by an external force during tuning.)
- Select a motor with the rated current equal to or less than the inverter rated current.

If a motor with substantially low rated current compared with the inverter rated current is used, speed accuracy may deteriorate due to torque ripples, etc. Set the rated motor current to about 40% or higher of the inverter rated current. (For details on the inverter rated current, refer to the inverter rated specifications in the Instruction Manual (Connection).)

- The maximum frequency under PM sensorless vector control is 400 Hz.
- Tuning is enabled even when a load is connected to the motor. The motor may run slightly. Fix the motor securely with a mechanical brake, or before tuning, make sure that it is safe even if the motor rotates. (Caution is required especially in vertical lift applications.) Note that even if the motor runs slightly, tuning performance is unaffected.

◆ Settings

- To perform tuning, set the following parameters about the motor.

Pr.	Name	Initial value	Description
80	Motor capacity	9999 (V/F control)	Set the motor capacity (kW).
81	Number of motor poles	9999 (V/F control)	Set the number of motor poles (2 to 12).
800	Control method selection	40	Set "10" (PM sensorless vector control).
9	Electronic thermal O/L relay	Inverter rated current	Set the rated motor current (A).
83	Rated motor voltage	200/400 V ^{*1}	Set the rated motor voltage (V) printed on the motor's rating plate.
84	Rated motor frequency	9999	Set the rated motor frequency (Hz). When "9999" is set, the inverter internal data is used.
71	Applied motor	0 (standard motor)	Set this parameter according to the motor. ^{*2}
96	Auto tuning setting/status	0	Set "1" or "11". 1 ^{*3} : Tuning is performed without the motor rotating (for a motor other than EM-A). 11: Tuning is performed without the motor rotating.

*1 The initial value differs according to the voltage class (100/200 V, 400 V).

*2 Set **Pr.71 Applied motor** according to the motor to be used. According to the **Pr.71** setting, the range of the motor constant parameter setting values and units can be changed. (For other setting values of **Pr.71**, refer to [page 261](#).)

Motor	Pr.71 setting	
	Motor constant parameter Ω, mH, and A unit setting	Motor constant parameter internal data setting
EM-A	1140	—
IPM motor	8090	8093
PM motor	9090	9093

*3 When the EM-A motor is used, the offline auto tuning cannot be performed.

- For tuning accuracy improvement, set the following parameters when the motor constants are known in advance.

Pr.	Name	Setting for a PM motor other than EM-A	Setting for EM-A
702	Maximum motor frequency	The maximum motor frequency (Hz)	9999 (initial value)
707	Motor inertia (integer)	Motor inertia ^{*1}	9999 (initial value)
724	Motor inertia (exponent)	$J_m = \text{Pr.707} \times 10^{(-\text{Pr.724})} \text{ (kg} \cdot \text{m}^2)$	
725	Motor protection current level	Maximum current level of the motor (%)	9999 (initial value)

*1 The setting is valid only when a value other than "9999" is set in both **Pr.707** and **Pr.724**.

◆ Performing tuning

Point

- Before performing tuning, check the monitor display of the operation panel or parameter unit if the inverter is in the state ready for tuning. The motor starts by turning ON the start command while tuning is unavailable.
- In the PU operation mode, press the RUN key on the operation panel or the FWD/REV key on the parameter unit. In the External operation, turn ON the start command (STF signal or STR signal). Tuning starts.

NOTE

- Satisfy the required inverter start conditions to start offline auto tuning. For example, stop the input of the MRS signal.
- To force tuning to end, use the MRS or RES signal or the STOP/RESET key on the PU. (Turning OFF the start signal (STF signal or STR signal) also ends tuning.)
- During offline auto tuning, only the following I/O signals are valid (initial value).
Input terminals <effective signals>: MRS, RES, STF, STR, S1, and S2
Output terminals: RUN, AM, ABC, and So (SO)
- When the rotation speed and the output frequency are selected for terminal AM, the progress status of offline auto tuning is output in 15 steps from AM.
- A motor with 14 or more poles cannot be tuned.
- Since the Inverter running (RUN) signal turns ON when tuning is started, pay close attention especially when a sequence which releases a mechanical brake by the RUN signal has been designed.
- When executing offline auto tuning, input the operation command after switching ON the main circuit power (R/L1, S/L2, T/L3) of the inverter.
- While **Pr.79 Operation mode selection** = "7", turn ON the PU operation external interlock (X12) signal for tuning in the PU operation mode.
- When offline auto tuning (**Pr.96 Auto tuning setting/status** ≠ "0") is performed during pre-excitation operation, pre-excitation is disabled.

- The tuning status (**Pr.96** setting value) is displayed on the operation panel.

Tuning status	Operation panel indication	
	Pr.96 = "1"	Pr.96 = "11"
(1) Setting		
(2) During tuning		
(3) Normal completion		

Tuning status	LCD operation panel (FR-LU08) display	
	Pr.96 = "1"	Pr.96 = "11"
(1) Setting		
(2) During tuning		
(3) Normal completion		

- Note: Offline auto tuning time (with the initial setting)

Offline auto tuning setting	Time
Pr.96 = "1"	Approx. 20 s
Pr.96 = "11"	Approx. 10 s

- When offline auto tuning ends, press the STOP/RESET key on the PU during PU operation. In the External operation mode, turn OFF the start signal (STF signal or STR signal). This operation resets the offline auto tuning, and the monitor display of the operation panel returns to normal. (Without this operation, next operation cannot be started.)

NOTE

- The motor constants measured once during offline auto tuning are stored as parameters and their data are held until offline auto tuning is performed again. However, the tuning data is cleared when performing All parameter clear.
- Changing **Pr.71** after tuning completion will change the motor constant. For example, if "8093" is set in **Pr.71** after tuning is performed with **Pr.71** = "8090", the tuning data becomes invalid. To use the tuned data, set "8090" again in **Pr.71**.

- If offline auto tuning has ended in error (refer to the following table), motor constants are not set. Perform an inverter reset and restart tuning.

Error display	Error cause	Countermeasures
8	Forced end	Set "1 or 11" in Pr.96 and retry.
9	Inverter protective function operation	Make the setting again.
92	The converter output voltage fell to 75% of the rated voltage.	Check for the power supply voltage fluctuation. Check the Pr.83 Rated motor voltage setting.
93	Calculation error. The motor is not connected.	Check the motor wiring and parameter settings, and make the setting again.

- When tuning is ended forcibly by pressing the STOP/RESET key or turning OFF the start signal (STF or STR) during tuning, offline tuning does not end properly. (The motor constants have not been set.)
Perform an inverter reset and perform tuning again.

NOTE

- An instantaneous power failure occurring during tuning will result in a tuning error.
After power is restored, the inverter starts normal operation. Therefore, when the STF (STR) signal is ON, the motor starts forward (reverse) rotation.
- Any fault occurring during tuning is handled as in the normal operation. However, if the retry function is set, no retry is performed even when a protective function that performs a retry is activated.
- The set frequency monitor displayed during the offline auto tuning is 0 Hz.

CAUTION

- Note that the motor may start running suddenly.

◆ Parameters updated by tuning results after tuning

Pr.	Name	Pr.96 setting		Description
		1	11	
90	Motor constant (R1)	○	○	Resistance per phase
92	Motor constant (L1)/d-axis inductance (Ld)	○	—	d-axis inductance
93	Motor constant (L2)/q-axis inductance (Lq)	○	—	q-axis inductance
711	Motor Ld decay ratio	○	—	d-axis inductance decay ratio
712	Motor Lq decay ratio	○	—	q-axis inductance decay ratio
717	Starting resistance tuning compensation coefficient	○	○	
721	Starting magnetic pole position detection pulse width	○	—	
859	Torque current/Rated PM motor current	○	—	
96	Auto tuning setting/status	○	○	

◆ Tuning adjustment (Pr.1002)

- The overcurrent protective function may be activated during Lq tuning for an easily magnetically saturated motor (motor with a large Lq decay ratio). In such case, adjust the target flowing current used for tuning with **Pr.1002 Lq tuning target current adjustment coefficient**.

◆ Changing the motor constants

- The motor constants can be set directly when the motor constants are known in advance, or by using the data measured during offline auto tuning.
- According to the **Pr.71** setting, the range of the motor constant parameter setting values and units can be changed. The changed settings are stored in the EEPROM as the motor constant parameters.

◆ Changing the motor constants (when setting motor constants in units of Ω , mH, or A)

- Set **Pr.71** as follows.

Motor	Pr.71 setting
EM-A	1140
IPM motor	8090
PM motor	9090

- Set desired values as the motor constant parameters.

Pr.	Name	Setting range	Setting increments	Initial value
90	Motor constant (R1)	0 to 50 Ω , 9999	0.001 Ω	9999
92	Motor constant (L1)/d-axis inductance (Ld)	0 to 500 mH, 9999	0.01 mH	
93	Motor constant (L2)/q-axis inductance (Lq)	0 to 500 mH, 9999	0.01 mH	
706	Motor induced voltage constant (phi f)	0 to 5000 mV (rad/s), 9999	0.1 mV (rad/s)	
859	Torque current/Rated PM motor current	0 to 500 A, 9999	0.01 A	
1412	Motor induced voltage constant (phi f) exponent	0 to 2, 9999	1	

NOTE

- If "9999" is set in the motor constant parameters, tuning data will be invalid and the inverter internal constant is used.
- To change a motor induced voltage constant of PM motors, the setting in **Pr.706 Motor induced voltage constant (phi f)** must be changed. If the constant after the change exceeds the setting range of **Pr.706** (0 to 5000 mV (rad/s)), set **Pr.1412 Motor induced voltage constant (phi f) exponent**. Set a value in the exponent n in the formula, **Pr.706** \times 10^n [mV (rad/s)], to set the induced voltage constant (phi f).
- When **Pr.71** = "8093 or 9093", or **Pr.1412** = "9999", the motor induced voltage constant is as set in **Pr.706**. (No exponent setting)

◆ Changing the motor constants (when setting a motor constants in the internal data of the inverter)

- Set **Pr.71** as follows.

Motor	Pr.71 setting
IPM motor	8093
PM motor	9093

- Set desired values as the motor constant parameters.

Pr.	Name	Setting range	Setting increments	Initial value
90	Motor constant (R1)	0 to ***, 9999	1	9999
92	Motor constant (L1)/d-axis inductance (Ld)			
93	Motor constant (L2)/q-axis inductance (Lq)			
706	Motor induced voltage constant (phi f)			
859	Torque current/Rated PM motor current			
1412	Motor induced voltage constant (phi f) exponent			

NOTE

- As the motor constants measured in the offline auto tuning have been converted into internal data (****), refer to the following setting example when making setting. (The value displayed has been converted into a value for internal use. Therefore, simple addition of a value to the displayed value does not bring the desired effect.)
Setting example: To slightly increase the **Pr.90** value (5%)
When "2516" is displayed for **Pr.90**, set 2642 ($2516 \times 1.05 = 2641.8$) in **Pr.90**.
- If "9999" is set in the motor constant parameters, tuning data will be invalid and the inverter internal constant is used.
- To change a motor induced voltage constant of PM motors, the setting in **Pr.706 Motor induced voltage constant (phi f)** must be changed. If the constant after the change exceeds the setting range of **Pr.706** (0 to 5000 mV (rad/s)), set **Pr.1412 Motor induced voltage constant (phi f) exponent**. Set a value in the exponent n in the formula, **Pr.706** $\times 10^n$ [mV (rad/s)], to set the induced voltage constant (phi f).
- When **Pr.71** = "8093 or 9093", or **Pr.1412** = "9999", the motor induced voltage constant is as set in **Pr.706**. (No exponent setting)

Parameters referred to

Pr.9 Electronic thermal O/L relay  [page 166](#)

Pr.71 Applied motor  [page 261](#)

13 (A) Application Parameters

Purpose	Parameter to set			Refer to page
To strengthen or weaken the frequency at a constant cycle	Traverse operation	P.A300 to P.A305	Pr.592 to Pr.597	281
To perform process control, such as for the pump flow volume and air volume	PID control	P.A601 to P.A604, P.A607, P.A610 to P.A615, P.A621 to P.A625	Pr.127 to Pr.134, Pr.553, Pr.554, Pr.575 to Pr.577, Pr.609, Pr.610, Pr.1015	283
	PID display adjustment	P.A630 to P.A633	C42 to C45 (Pr.934, Pr.935)	297
To control the dance roll for winding/unwinding	Dancer control	P.A601, P.A602, P.A610, P.A611, P.A613 to P.A615, P.A624, P.A625, P.F020, P.F021	Pr.44, Pr.45, Pr.128 to Pr.134, Pr.609, Pr.610	300
To restart without stopping the motor at instantaneous power failure	Automatic restart after instantaneous power failure / flying start function for induction motors	P.A700 to P.A703, P.A710, P.F003	Pr.57, Pr.58, Pr.162, Pr.165, Pr.299, Pr.611	307
	Frequency search accuracy improvement (V/F control, offline auto tuning)	P.A700, P.A711, P.C110, P.C120	Pr.90, Pr.96, Pr.162, Pr.298	314
	Automatic restart after instantaneous power failure / flying start function for PM motors	P.A700, P.A702, P.F003	Pr.57, Pr.162, Pr.611	312
To decelerate the motor to a stop at power failure	Power failure time deceleration-to-stop function	P.A730	Pr.261	318
To store the operating status of the inverter in the RAM in the inverter	Trace function	P.A900, P.A902 to P.A906, P.A910 to P.A920, P.A930 to P.A939	Pr.1020, Pr.1022 to Pr.1047	320

13.1 Traverse function

The traverse operation, which oscillates the frequency at a constant cycle, is available.

Pr.	Name	Initial value	Setting range	Description
592 A300	Traverse function selection	0	0	Traverse function invalid
			1	Traverse function valid only in External operation mode
			2	Traverse function valid regardless of the operation mode
593 A301	Maximum amplitude amount	10%	0% to 25%	Level of amplitude during traverse operation
594 A302	Amplitude compensation amount during deceleration	10%	0% to 50%	Compensation amount during amplitude inversion (from acceleration to deceleration)
595 A303	Amplitude compensation amount during acceleration	10%	0% to 50%	Compensation amount during amplitude inversion (from deceleration to acceleration)
596 A304	Amplitude acceleration time	5 s	0.1 to 3600 s	Time period of acceleration during traverse operation
597 A305	Amplitude deceleration time	5 s	0.1 to 3600 s	Time period of deceleration during traverse operation

- **Setting Pr.592 Traverse function selection** = "1 or 2" enables the traverse function.
- Assigning the Traverse function selection (X37) signal to the input terminal enables the traverse function only when the X37 signal is ON. (When the X37 signal is not assigned, the traverse function is always available. When the Network operation mode is selected, the traverse function is always available regardless of ON/OFF state of the X37 signal.) To input the X37 signal, set "37" in any parameter from **Pr.178 to Pr.182 and Pr.185 to Pr.189 (Input terminal function selection)** to assign the function.

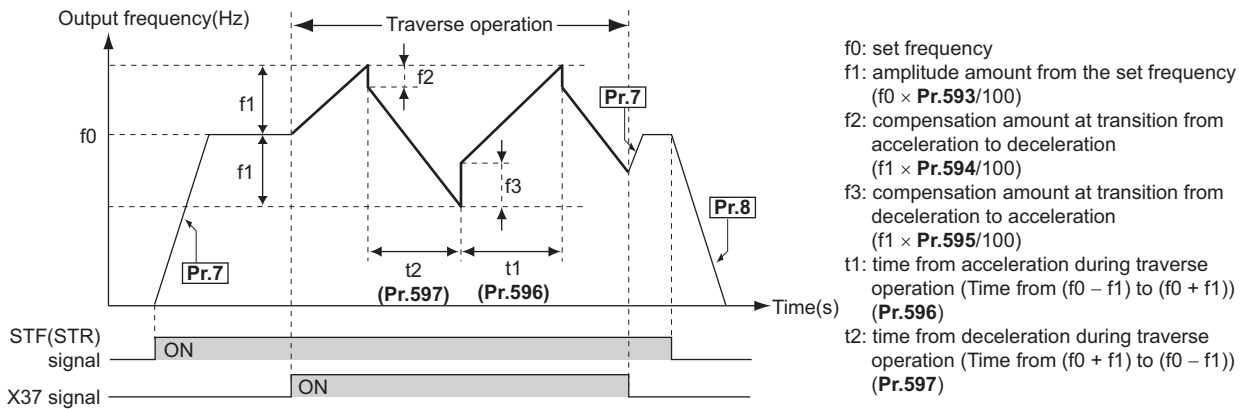

- The motor accelerates to the set frequency f_0 according to the normal **Pr.7 Acceleration time** at turn ON of the start command (STF or STR).
- When the output frequency reaches f_0 and the X37 signal turns ON, the inverter begins traverse operation and accelerates to $f_0 + f_1$. The acceleration time at this time is according to the **Pr.596** setting. (If the X37 signal turns ON before the output frequency reaches f_0 , traverse operation begins after the output frequency reaches f_0 .)
- After the inverter accelerates the motor to $f_0 + f_1$, this is compensated with f_2 ($f_1 \times \text{Pr.594}$), and the motor decelerates to $f_0 - f_1$. The deceleration time at this time is according to the **Pr.597** setting.
- After the inverter decelerates the motor to $f_0 - f_1$, this is compensated with f_3 ($f_1 \times \text{Pr.595}$), and the motor accelerates again to $f_0 + f_1$.
- When the X37 signal turns OFF during traverse operation, the inverter accelerates/decelerates the motor to f_0 according to the normal acceleration/deceleration time (**Pr.7, Pr.8**). If the start command (STF or STR) is turned OFF during traverse operation, the inverter decelerates the motor to a stop according to the normal deceleration time (**Pr.8**).

NOTE

- If the set frequency (f_0) and traverse operation parameters (**Pr.593 to Pr.597**) are changed during traverse operation, this is applied in operations after the output frequency reaches f_0 before the change was made.
- If the output frequency exceeds the setting of **Pr.1 Maximum frequency** or **Pr.2 Minimum frequency** during traverse operation, the output frequency is clamped at the maximum/minimum frequency when the set pattern exceeds the maximum/minimum frequency. (The output frequency is not clamped at minimum frequency during JOG operation.)
- When the traverse function and S-pattern acceleration/deceleration (**Pr.29 \neq "0"**) are selected, S-pattern acceleration/deceleration operation occurs only in the range operated at the normal acceleration/deceleration time (**Pr.7, Pr.8**). Acceleration/deceleration during traverse operation is performed linearly.
- If stall prevention activates during traverse operation, traverse operation stops and normal operation begins. When stall prevention operation is completed, the inverter accelerates/decelerates the motor to f_0 at the normal acceleration/deceleration time (**Pr.7, Pr.8**). After the output frequency reaches f_0 , the traverse operation begins again.
- If the value of the amplitude inversion compensation amount (**Pr.594, Pr.595**) is too large, an overvoltage trip or stall prevention occurs, and pattern operation cannot be performed as set.
- Changing the terminal assignment using **Pr.178 to Pr.182 and Pr.185 to Pr.189 (Input terminal function selection)** may affect the other functions. Set parameters after confirming the function of each terminal.

Parameters referred to

Pr.29 Acceleration/deceleration pattern selection [page 133](#)

Pr.178 to Pr.182 and Pr.185 to Pr.189 (Input terminal function selection) [page 252](#)

13.2 PID control

Process control such as flow rate, air volume or pressure is possible on the inverter.

A feedback system can be configured and PID control can be performed with the set point and feed back values set by analog input signals (terminals 2 and 4) or using parameter values given via communication.

Pr.	Name	Initial value	Setting range	Description
127 A612	PID control automatic switchover frequency	9999	0 to 590 Hz	Set the value at which control is automatically switched to PID control.
			9999	No PID control automatic switchover function
128 A610	PID action selection	0	0, 20, 21, 1000, 1001, 1010, 1011, 2000, 2001, 2010, 2011	Select how to input the deviation value, measured value and set point, and forward and reverse action.
			40 to 43	Refer to page 300 .
129 A613	PID proportional band	100%	0.1% to 1000%	If a narrow proportional band is set (small parameter setting value), the manipulated amount changes considerably by slight changes in the measured value. As a result, response improves as the proportional band becomes narrower, though stability worsens as shown by the occurrence of hunting. Gain $K_p=1/\text{proportional band}$
			9999	No proportional control
130 A614	PID integral time	1 s	0.1 to 3600 s	With deviation step input, this is the time (Ti) used for obtaining the same manipulated amount as proportional band (P) by only integral (I) action. Arrival to the set point becomes quicker the shorter an integral time is set, though hunting is more likely to occur.
			9999	No integral control
131 A601	PID upper limit	9999	0% to 100%	Set the upper limit. The FUP signal is output when the feedback value exceeds this setting. The maximum input (20 mA/5 V/10 V) of the measured value is equivalent to 100%.
			9999	No function
132 A602	PID lower limit	9999	0% to 100%	Set the lower limit. The FDN signal is output when the measured value falls below the setting range. The maximum input (20 mA/5 V/10 V) of the measured value is equivalent to 100%.
			9999	No function
133 A611	PID action set point	9999	0% to 100%	Set the set point during PID control.
			9999	Set point set by Pr.128 .
134 A615	PID differential time	9999	0.01 to 10 s	With deviation ramp input, this is the time (Td) used for obtaining the manipulated amount only by proportional action (P). Response to changes in deviation increase greatly as the differential time increases.
			9999	No differential control
553 A603	PID deviation limit	9999	0% to 100%	The Y48 signal is output when the absolute value of the deviation exceeds the deviation limit value.
			9999	No function
554 A604	PID signal operation selection	0	0 to 3, 10 to 13	The action when the upper or lower limit for a measured value input is detected or when a limit for the deviation is detected can be selected. The operation for PID output suspension function can be selected.
			9999	No output interruption function
575 A621	Output interruption detection time	1 s	0 to 3600 s	When the output frequency after PID calculation stays less than the Pr.576 setting for the time set in Pr.575 or more, the inverter operation is suspended.
			9999	No output interruption function
576 A622	Output interruption detection level	0 Hz	0 to 590 Hz	Set the frequency at which output interruption is performed.
577 A623	Output interruption cancel level	1000%	900% to 1100%	Level at which the PID output suspension function is released. Set " Pr.577 - 1000%".
609 A624	PID set point/deviation input selection	2	2	The set point or deviation value is input through terminal 2.
			3	The set point or deviation value is input through terminal 4.
610 A625	PID measured value input selection	3	2	The measured value is input through terminal 2.
			3	The measured value is input through terminal 4.

Pr.	Name	Initial value	Setting range	Description
1015 A607	Integral stop selection at limited frequency	10	0	The integral stops when the manipulated amount is limited. The range is ±100% for the manipulated amount. The integral is cleared during output interruption.
			1	The integral does not stop when the manipulated amount is limited. The range is ±100% for the manipulated amount. The integral is cleared during output interruption.
			2	The integral stops when the manipulated amount is limited. The range is 0% to 100% for the manipulated amount. The integral is cleared during output interruption.
			10	The integral stops when the manipulated amount is limited. The range is ±100% for the manipulated amount. The integral stops during output interruption.
			11	The integral does not stop when the manipulated amount is limited. The range is ±100% for the manipulated amount. The integral stops during output interruption.
			12	The integral stops when the manipulated amount is limited. The range is 0% to 100% for the manipulated amount. The integral stops during output interruption.

◆ Basic configuration of PID control

■ Pr.128 = "1010, 1011, 2010, 2011" (deviation input)

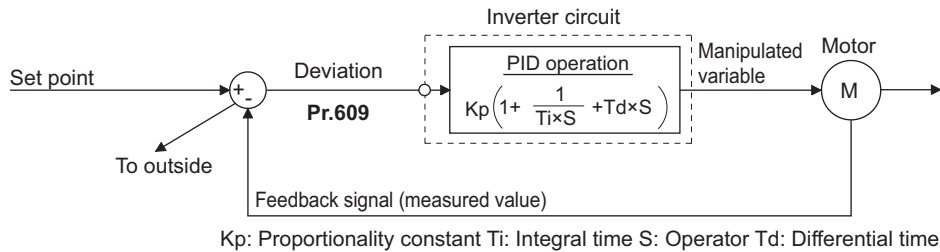

■ Pr.128 = "20, 21" (measured value input)

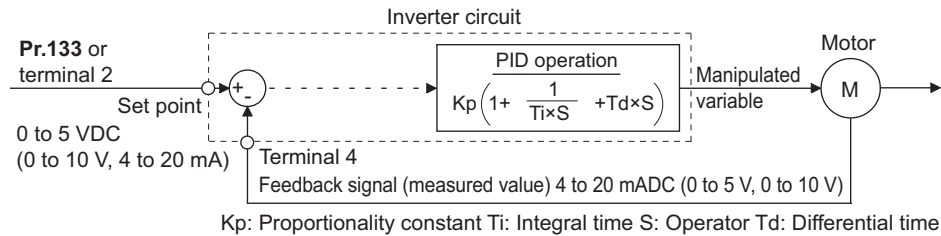

◆ PID action outline

■ PI action

PI action is a combination of proportional action (P) and integral action (I), and applies a manipulated amount according to the size of the deviation and transition or changes over time.

[Example of action when the measured value changes in a stepped manner]

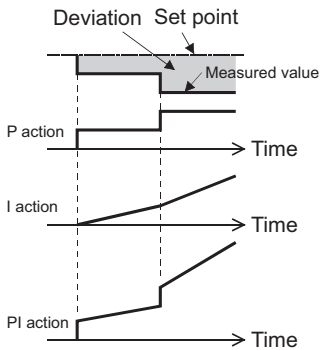

(Note) PI action is the result of P and I actions being added together.

■ PD action

PD action is a combination of proportional action (P) and differential action (D), and applies a manipulated amount according to the speed of the deviation to improve excessive characteristics.

[Example of action when the measured value changes proportionately]

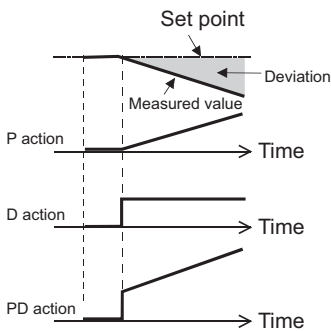

(Note) PD action is the result of P and D actions being added together.

■ PID action

PID action is a combination of PI and PD action, which enables control that incorporates the respective strengths of these actions.

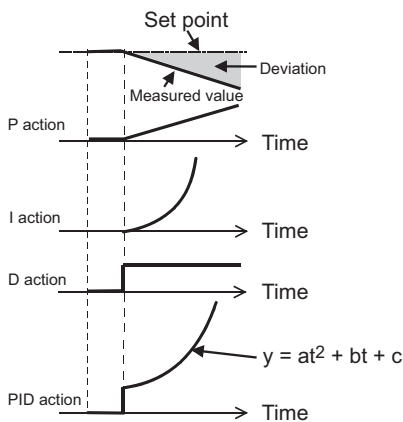

(Note) PID action is the result of all P, I, and D actions being added together.

Reverse action

When deviation $X = (\text{set point} - \text{measured value})$ is a plus value, the manipulated amount (output frequency) is increased, and when the deviation is a minus value, the manipulated amount is decreased.

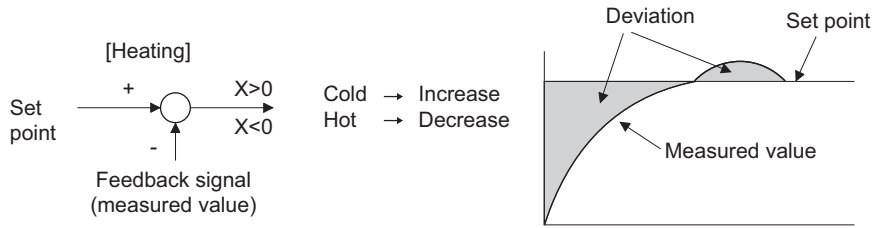

Forward action

When deviation $X = (\text{set point} - \text{measured value})$ is a minus value, the manipulated amount (output frequency) is increased, and when the deviation is a plus value, the manipulated amount is decreased.

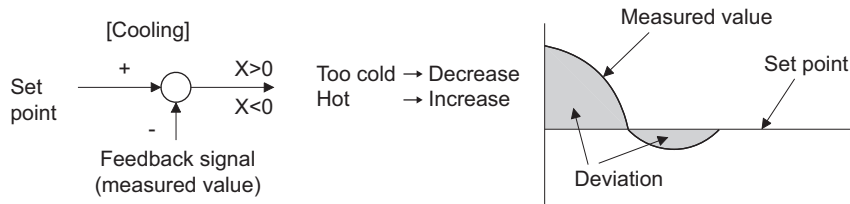

Relationship between deviation and manipulated amount (output frequency)

PID action setting	Deviation	
	Plus	Minus
Reverse action	↗	↘
Forward action	↘	↗

Connection diagram

- Sink logic
- Pr.128 = "20"
- Pr.182 = "14"
- Pr.190 = "15"
- Pr.191 = "14"
- Pr.192 = "16"

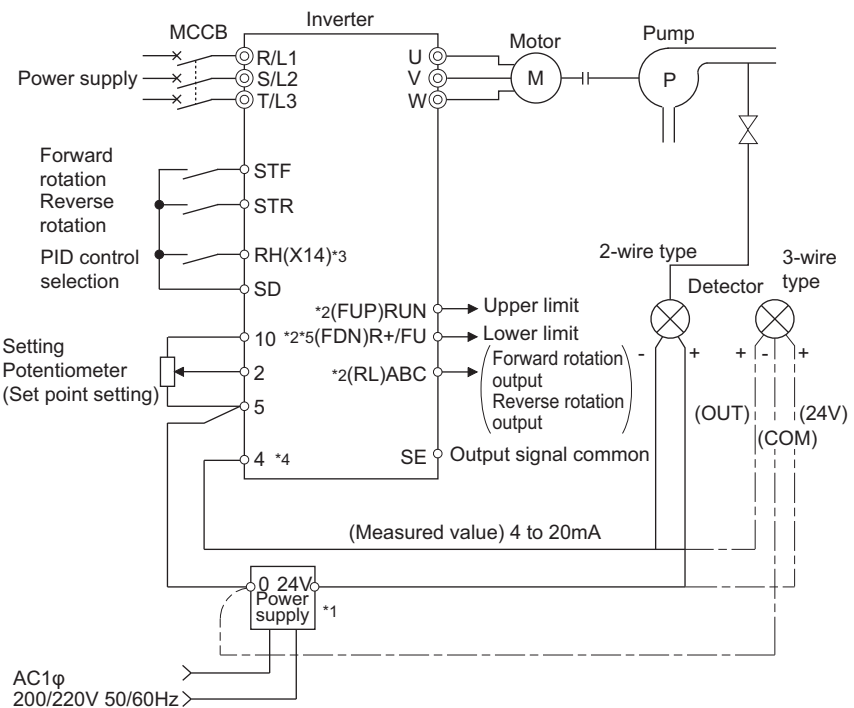

- *1 Prepare a power supply matched to the power supply specifications of the detector.
- *2 The applied output terminals differ by the settings of Pr.190 to Pr.196 (Output terminal function selection).
- *3 The applied input terminals differ by the settings of Pr.178 to Pr.182 and Pr.185 to Pr.189 (Input terminal function selection). Assigning the PID control valid (X14) signal to an input terminal enables PID control to be performed only when the X14 signal is turned ON.
- *4 The AU signal need not be input.
- *5 When the R+/FU switch (SW5) is set to the upper position (FU) (initial status), the assigned function is enabled. Assignment is not available when the RS-485 terminal is used for RS-485 communication. For details, refer to the Instruction Manual (Connection) and the Instruction Manual (Communication).

◆ Selection of deviation value, measured value and set point input method, and PID action method (Pr.128, Pr.609, Pr.610)

- Using **Pr.128**, select the input method for the PID set point, measured value detected by the meter, and externally calculated deviation. Also, select forward or reverse action.
- Switch the power voltage/current specifications of terminals 2 and 4 by **Pr.73 Analog input selection** or **Pr.267 Terminal 4 input selection** to match the specification of the input device. After changing the **Pr.73** or **Pr.267** setting, check the voltage/current input switch. Incorrect setting may cause a fault, failure or malfunction. (Refer to [page 243](#) for the setting.)

Pr.128 setting	Pr.609 Pr.610	PID action	Set point input	Measured value input	Deviation input
0	Invalid	PID invalid	—	—	—
20		Reverse action	Terminal 2 or Pr.133 ^{*1}	Terminal 4	—
21		Forward action			
40 to 43	Enabled	Dancer control	For details on dancer control, refer to page 300 .		
1000	Enabled	Reverse action	According to Pr.609 ^{*1}	According to Pr.610	—
1001		Forward action			
1010		Reverse action	—	—	According to Pr.609 .
1011		Forward action	According to Pr.609 ^{*1}	According to Pr.610	—
2000		Reverse action (without frequency reflected)			
2001		Forward action (without frequency reflected)			
2010		Reverse action (without frequency reflected)	—	—	According to Pr.609
2011		Forward action (without frequency reflected)			

*1 When **Pr.133** ≠ "9999", the **Pr.133** setting is valid.

- The set point/deviation input method can also be flexibly selected by **Pr.609 PID set point/deviation input selection** and the measured value input method can be selected by **Pr.610 PID measured value input selection**. Selection by **Pr.609** and **Pr.610** is valid when **Pr.128** = "1000 to 2011".

Pr.609 and Pr.610 settings	Input method
2	Terminal 2 ^{*2}
3	Terminal 4 ^{*2}

*2 When the same input method has been selected for the set point and measured value at **Pr.609** and **Pr.610**, set point input is invalid. (Inverter runs at set point 0%)

NOTE

- When terminals 2 and 4 are selected for deviation input, perform bias calibration using **C3 (Pr.902)** and **C6 (Pr.904)** to prevent a minus voltage from being entered as the deviation input signal. Input of a minus voltage might damage devices and the inverter.

- The following shows the relationship between the input values of the analog input terminals and set point, measured value and deviation. (Calibration parameter initial values)

Input terminal	Input specification ^{*3}	Relationship with analog input			Calibration parameter
		Set point	Result	Deviation	
Terminal 2	0 to 5 V	0 V = 0% 5 V = 100%	0 V = 0% 5 V = 100%	0 V = 0% 5 V = 100%	Pr.125, C2 to C4 (Pr.902, Pr.903)
	0 to 10 V	0 V = 0% 10 V = 100%	0 V = 0% 10 V = 100%	0 V = 0% 10 V = 100%	
	0 to 20 mA	0 mA = 0% 20 mA = 100%	0 mA = 0% 20 mA = 100%	0 mA = 0% 20 mA = 100%	
Terminal 4	0 to 5 V	0 to 1 V = 0% 5 V = 100%	0 to 1 V = 0% 5 V = 100%	0 V = -20% 1 V = 0% 5 V = 100%	Pr.126, C5 to C7 (Pr.904, Pr.905)
	0 to 10 V	0 to 2 V = 0% 10 V = 100%	0 to 2 V = 0% 10 V = 100%	0 V = -20% 2 V = 0% 10 V = 100%	
	0 to 20 mA	0 to 4 mA = 0% 20 mA = 100%	0 to 4 mA = 0% 20 mA = 100%	0 mA = -20% 4 mA = 0% 20 mA = 100%	

*3 Can be changed by **Pr.73 Analog input selection** and **Pr.267 Terminal 4 input selection** and the voltage/current input switch. (Refer to [page 243.](#))

NOTE

- Always calibrate the input after changing the voltage/current input specification with **Pr.73** and **Pr.267**, and the voltage/current input switch.

◆ Input/output signals

- Assigning the PID control valid (X14) signal to the input terminal by **Pr.178 to Pr.182 and Pr.185 to Pr.189 (Input terminal function selection)** enables PID control to be performed only when the X14 signal is turned ON. When the X14 signal is OFF, regular inverter running is performed without PID action. (When the X14 signal is not assigned, PID control is enabled only by setting **Pr.128** ≠ "0".)
- Input signal

Signal	Function	Pr.178 to Pr.182, Pr.185 to Pr.189 setting	Description
X14	PID control valid	14	When this signal is assigned to the input terminal, PID control is enabled when this signal is ON.
X64	PID forward/reverse action switchover	64	Used to switch between forward and reverse action.
X72	PID P control switchover	72	Only proportional term is valid when this signal is turned ON. (Integral and differential values are reset.)

- Output signal

Signal	Function	Pr.190 to Pr.196 settings		Description
		Positive logic	Negative logic	
FUP	PID upper limit	15	115	Output when the measured value signal exceeds Pr.131 PID upper limit .
FDN	PID lower limit	14	114	Output when the measured value signal falls below Pr.132 PID lower limit .
RL	PID forward/ reverse rotation output	16	116	"Hi" is output when the output display of the operation panel is forward rotation (the RUN LED is ON) and "Low" is output when the display is reverse rotation (the RUN LED blinks) and stop (the RUN LED is OFF). "Hi" is output when the output display of the parameter unit is forward rotation (FWD) and "Low" is output when the display is reverse rotation (REV) and stop (STOP).
PID	During PID control activated	47	147	Turns ON during PID control. When the PID calculation result is reflected to the output frequency (Pr.128 < "2000"), the PID signal turns OFF at turn OFF of the start signal. When the result is not reflected to the output frequency (Pr.128 ≥ "2000"), the PID signal turns ON during PID calculation regardless of the start signal status.
Y48	PID deviation limit	48	148	Output when the absolute deviation value exceeds the limit value set in Pr.553 PID deviation limit .
SLEEP	PID output interruption	70	170	Set Pr.575 Output interruption detection time ≠ "9999". This signal turns ON when the PID output suspension function is activated.

NOTE

- Changing the terminal functions with **Pr.178 to Pr.182, Pr.185 to Pr.189, and Pr.190 to Pr.196** may affect other functions. Set parameters after confirming the function of each terminal.

◆ PID automatic switchover control (Pr.127)

- The system can be started up more quickly by starting up without PID control activated.
- When **Pr.127 PID control automatic switchover frequency** is set, the startup is made without PID control until the output frequency reaches the **Pr.127** setting. Once the PID control starts, the PID control is continued even if the output frequency drops to **Pr.127** setting or lower.

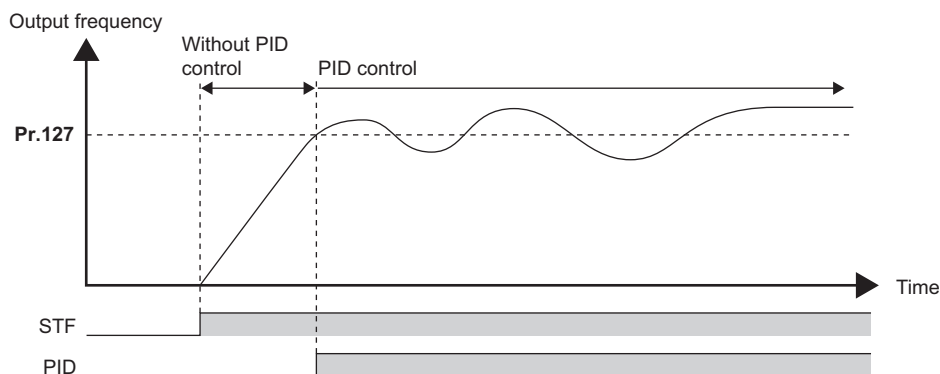

◆ Operation selection and sleep function stop selection when a value error is detected (FUP signal, FDN signal, Y48 signal, Pr.554)

- Using **Pr.554 PID signal operation selection**, set the action when the measured value input exceeds the upper limit (**Pr.131 PID upper limit**) or lower limit (**Pr.132 PID lower limit**), or when the deviation input exceeds the permissible value (**Pr.553 PID deviation limit**).
- Choose whether to output the signals (FUP, FDN, Y48) only or to activate the protective function to output the inverter shutoff.
- The stop action when the inverter output is shut off by the sleep function can be selected.

Pr.554 setting	Inverter operation		
	At FUP/FDN signal output ^{*1}	At Y48 signal output ^{*1}	At sleep operation start
0 (initial value)	Signal output only	Signal output only	Coasts to stop
1	Signal output + output shutoff (E.PID)	Signal output + output shutoff (E.PID)	
2	Signal output only		
3	Signal output + output shutoff (E.PID)	Signal output only	Deceleration stop
10	Signal output only		
11	Signal output + output shutoff (E.PID)		
12	Signal output only	Signal output + output shutoff (E.PID)	
13	Signal output + output shutoff (E.PID)		

*1 When each of **Pr.131**, **Pr.132** and **Pr.553** settings corresponding to each of the FUP, FDN and Y48 signals is "9999" (no function), signal output and protective function are not available.

◆ PID output suspension function (sleep function) (SLEEP signal, Pr.575 to Pr.577)

- When a status where the output frequency after PID calculation is less than **Pr.576 Output interruption detection level** has continued for the time set in **Pr.575 Output interruption detection time** or longer, inverter running is suspended. This allows the amount of energy consumed in the inefficient low-speed range to be reduced.
- When the deviation (set point - measured value) reaches the PID output shutoff release level (**Pr.577** setting value -1000%) while the PID output suspension function is activated, the PID output suspension function is released, and PID control operation is automatically restarted.
- Whether to allow motor to coast to a stop or perform a deceleration stop when sleep operation is started can be selected using **Pr.554**.
- While the PID output suspension function is activated, the PID output interruption (SLEEP) signal is output. During this time, the Inverter running (RUN) signal turns OFF and the During PID control activated (PID) signal turns ON.
- For the SLEEP signal output, set "70" (positive logic) or "170" (negative logic) in any parameter from **Pr.190 to Pr.196 (Output terminal function selection)** to assign the function.

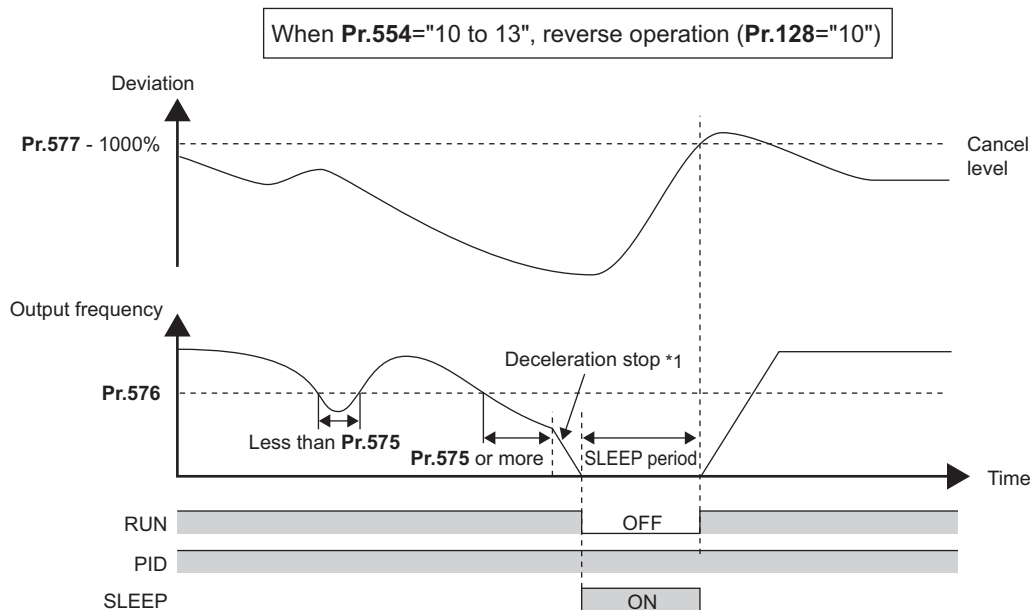
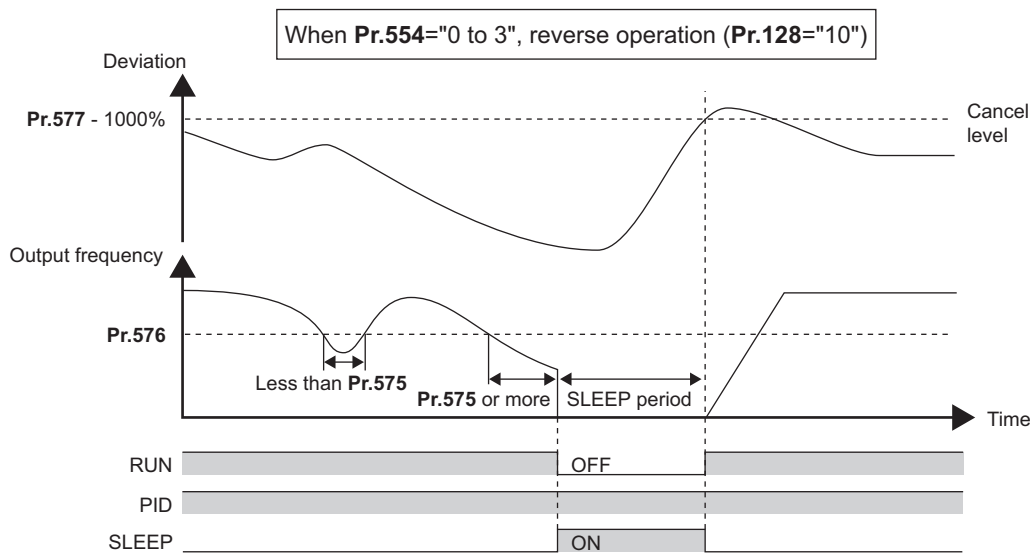

*1 When the PID output shutoff release level is reached during a deceleration stop, output shutoff is released, operation is re-accelerated and PID control is continued. During deceleration, **Pr.576 Output interruption detection level** is invalid.

◆ Integral stop selection when the frequency is limited (Pr.1015)

- The operation for the integral term can be selected when the frequency or the manipulated amount is limited during PID control.
- The manipulation range can be selected.
- The operation during output interruption can be selected for the integral term using the PID output suspension (SLEEP) function.

Pr.1015 setting	Operation at limited frequency	Range of manipulation	Operation during PID output interruption
0	Integral stop	-100% to +100%	Integral clear
1	Integral does not stop.*1		
2	Integral stop	0% to 100%	Integral stop
10 (initial value)	Integral stop	-100% to +100%	
11	Integral does not stop.*1		
12	Integral stop	0% to 100%	

*1 When the frequency reaches the upper limit, or when the PID manipulated amount reaches 100%, the integral stops and the integral term is retained. When the frequency decreases, the integral does not stop until the manipulated amount reaches -100%, regardless of the output frequency.

NOTE

- While the integral stop is selected, the integral stop is enabled when any of the following conditions is met.

Integral stop conditions
<ul style="list-style-type: none"> • The frequency reaches the upper or lower limit. • The manipulated amount reaches plus or minus 100% (Pr.1015 = "0 or 10"). • The manipulated amount reaches 0% or 100% (Pr.1015 = "2 or 12").

◆ PID monitor function

- This function displays the PID control set point, measured value and deviation on the operation panel, and can output these from terminal AM.
- An integral value indicating a negative % can be displayed on the deviation / manipulated amount monitor. 0% is displayed as 1000. (These values cannot be output on the deviation / manipulated amount monitor from terminal AM.)
- Set the following values to **Pr.52 Operation panel main monitor selection**, **Pr.774 to Pr.776 (Operation panel monitor selection)**, **Pr.992 Operation panel setting dial push monitor selection**, and **Pr.158 AM terminal function selection** for each monitor.

Parameter setting	Monitor description	Minimum increment	Monitor range		Remarks
			Terminal AM	Operation panel	
52	PID set point	0.1%	0% to 100%*1		"0" is displayed at all times when PID control is based in deviation input.
53	PID measured value				
67	PID measured value 2	0.1%	0% to 100%*1		Displays PID measured value even if the PID control operating conditions are not satisfied while the PID control is enabled. "0" is displayed at all times when PID control is based in deviation input.
54	PID deviation	0.1%	Setting not available	900% to 1100%	The indicated values are from "900%" to "1100%" on the operation panel. (0% is offset and displayed as "1000%.")
91	PID manipulated amount	0.1%	Setting not available	900% to 1100%	

*1 When C42 (Pr.934) and C44 (Pr.935) are set, the minimum increment changes from unit % to no unit, and the monitor range can be changed. (Refer to page 297.)

◆ Adjustment procedure

- 1.** Enable PID control
When **Pr.128** ≠ "0", PID control is enabled.
Set the set point, measured value and deviation input methods at **Pr.128, Pr.609 and Pr.610**.
- 2.** Setting the parameter
Adjust the PID control parameters of **Pr.127, Pr.129 to Pr.134, Pr.553, Pr.554, Pr.575 to Pr.577**.
- 3.** Terminal setting
Set the I/O terminals for PID control. (**Pr.178 to Pr.182 and Pr.185 to Pr.189 (Input terminal function selection), Pr.190 to Pr.196 (Output terminal function selection)**)
- 4.** Turing ON the X14 signal assigned to the input terminal
When the X14 signal is assigned to the input terminal, PID control is enabled by the X14 signal turning ON.
- 5.** Operation

◆ Calibration example

(Adjust room temperature to 25°C by PID control using a detector that outputs 4 mA at 0°C and 20 mA at 50°C.)

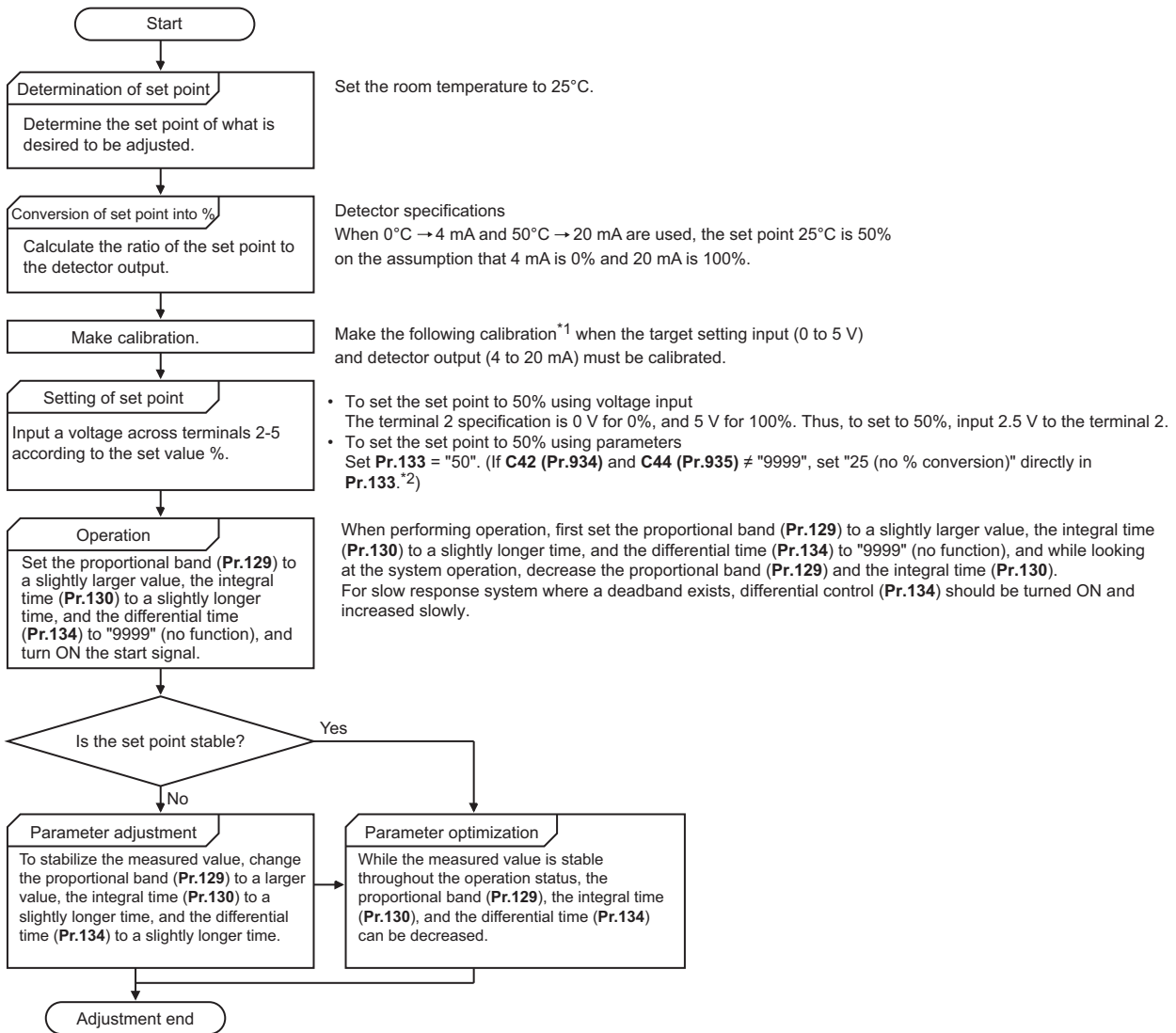

*1 When calibration is required

Calibrate detector output and set point input by Pr.125, C2 (Pr.902) to C4 (Pr.903) (terminal 2) or Pr.126, C5 (Pr.904) to C7 (Pr.905) (terminal 4). (Refer to page 248.)

When both C42 (Pr.934) and C44 (Pr.935) ≠ "9999", calibrate the detector output and set point input by C42 (Pr.934) and C44 (Pr.935). (Refer to page 297.)

Make calibration in the PU operation mode during an inverter stop.

*2 This means 25°C in the calibration example.

- Calibrating set point input

(Example: To enter the set point on terminal 2)

1. Apply the input (for example, 0 V) of set point setting 0% across terminals 2 and 5.
2. Using **C2 (Pr.902)**, enter the frequency (for example, 0 Hz) to be output by the inverter when the deviation is 0%.
3. Using **C3 (Pr.902)**, set the voltage value at 0%.
4. Apply the input (for example, 5 V) of set point setting 100% across terminals 2 and 5.
5. Using **Pr.125**, enter the frequency (for example, 60 Hz) to be output by the inverter when the deviation is 100%.
6. Using **C4 (Pr.903)**, set the voltage value at 100%.

NOTE

- When the set point is set by using **Pr.133**, the setting frequency of **C2 (Pr.902)** is equivalent to 0% and the setting frequency of **Pr.125** is equivalent to 100%.

- Measured value input calibration

1. Apply the input (for example, 4 mA) of measured value 0% across terminals 4 and 5.
2. Perform calibration by **C6 (Pr.904)**.
3. Apply the input (for example, 20 mA) of measured value 100% across terminals 4 and 5.
4. Perform calibration by **C7 (Pr.905)**.

NOTE

- Set the frequencies set in **C5 (Pr.904)** and **Pr.126** to each of the same values set in **C2 (Pr.902)** and **Pr.125**.
- The display unit for analog input can be changed from "%" to "V" or "mA". (Refer to [page 248](#).)

- The following figure shows the results of having performed the calibration above.

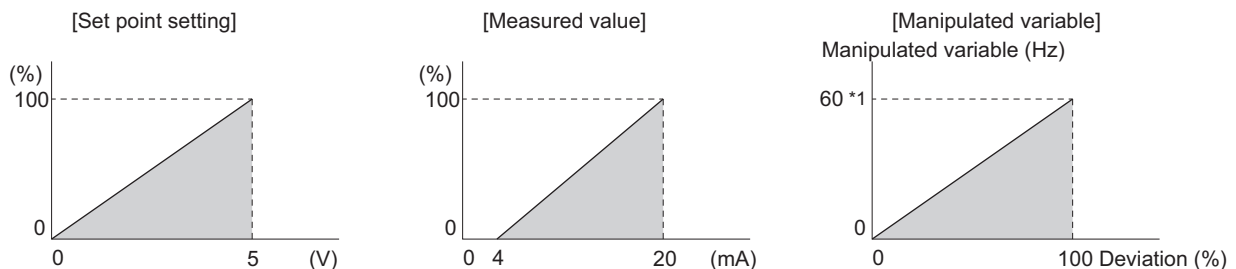

*1 The upper limit of the manipulated amount is the **Pr.125** setting value.

NOTE

- The priority of the frequency command given by the external signals is as follows: JOG operation (JOG/JOG2 signal) > multi-speed operation (RL/RM/RH/REX signal) > PID control (X14 signal) > terminal 4 analog input (AU signal) > pulse train input > terminal 2 analog input.
- Even if the X14 signal is ON, PID control is stopped and multi-speed or JOG operation is performed when the multi-speed operation (RH, RM, RL, or REX) signal or JOG signal (JOG operation) is input.
- PID control is invalid under the following settings.

Pr.79 Operation mode selection = "6" (Switchover mode)

- Changing the terminal functions with **Pr.178 to Pr.182**, **Pr.185 to Pr.189**, and **Pr.190 to Pr.196** may affect other functions. Set parameters after confirming the function of each terminal.
- During PID operation, the remote operation function is invalid.
- When control is switched to PID control during normal operation, the frequency during that operation is not carried over, and the value resulting from PID calculation referenced to 0 Hz becomes the command frequency.

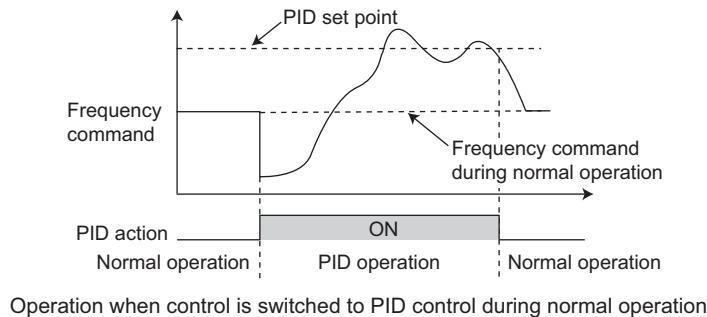
**Parameters referred to**

- Pr.59 Remote function selection** [page 135](#)
- Pr.73 Analog input selection** [page 243](#)
- Pr.79 Operation mode selection** [page 142](#)
- Pr.178 to Pr.182 and Pr.185 to Pr.189 (Input terminal function selection)** [page 252](#)
- Pr.190 to Pr.196 (Output terminal function selection)** [page 226](#)
- C2 (Pr.902) to C7 (Pr.905) Frequency setting voltage (current) bias/gain** [page 248](#)

13.3 Calibration of PID display

When the LCD operation panel (FR-LU08) or the parameter unit (FR-PU07) is used, the display unit of parameters and monitor items related to PID control can be changed to various units.

Pr.	Name	Initial value	Setting range	Description
759 A600	PID unit selection	0	0 to 43	Change the unit of the PID control-related values that is displayed on the LCD operation panel (FR-LU08) or the parameter unit (FR-PU07).
			9999	Without display unit switching
C42 (934) A630 ^{*1}	PID display bias coefficient	9999	0 to 500	Set the coefficient of the bias side (minimum) of measured value input.
			9999	Displayed in %.
C43 (934) A631 ^{*1}	PID display bias analog value	20%	0% to 300%	Set the converted % of the bias side (minimum) current/voltage of measured value input.
C44 (935) A632 ^{*1}	PID display gain coefficient	9999	0 to 500	Set the coefficient of the gain side (maximum) of measured value input.
			9999	Displayed in %.
C45 (935) A633 ^{*1}	PID display gain analog value	100%	0% to 300%	Set the converted % of the gain side (maximum) current/voltage of measured value input.

*1 On the LCD operation panel or the parameter unit used as the command source, the parameter number in parentheses appears instead of that starting with the letter C.

◆ Calibration of PID display bias and gain (C42 (Pr.934) to C45 (Pr.935))

- When both **C42 (Pr.934)** and **C44 (Pr.935)** ≠ "9999", the bias and gain values for the set point, measured value and deviation in PID control can be calibrated.
- "Bias"/"gain" function can adjust the relation between PID displayed coefficient and measured value input signal that is externally input. Examples of these measured value input signals are 0 to 5 VDC, 0 to 10 VDC, or 4 to 20 mA DC. (The terminals used for measured value input can be selected at **Pr.128**, **Pr.609**, **Pr.610**.)
- Set the value that is displayed when the PID measured value (control amount) is 0% to **C42 (Pr.934)** and the value that is displayed when the PID measured value (control amount) is 100% to **C44 (Pr.935)**.
- When both **C42 (Pr.934)** and **C44 (Pr.935)** ≠ "9999" and **Pr.133** is set as the set point, the setting of **C42 (Pr.934)** is treated as 0%, and **C44 (Pr.935)** as 100%.

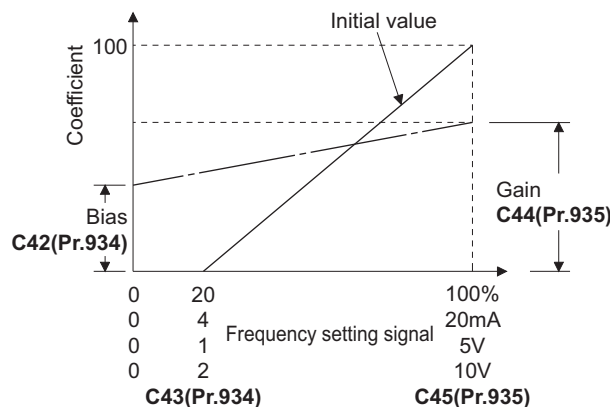

- There are three methods to adjust the PID display bias/gain.
 - Method to adjust any point by application of a current (voltage) to the measured value input terminal
 - Method to adjust any point without application of a current (voltage) to the measured value input terminal
 - Method to adjust only the display coefficient without adjustment of current (voltage)

(Refer to [page 248](#) for details, and make the necessary adjustments by considering **C7 (Pr.905)** as **C45 (Pr.935)** and **Pr.126** as **C44 (Pr.935)**.)

NOTE

- Always calibrate the input after changing the voltage/current input specification with **Pr.73** and **Pr.267**, and the voltage/current input switch.

- Take caution when the following condition is satisfied because the inverter recognizes the deviation value as a negative (positive) value even though a positive (negative) deviation is given: **C42** (PID bias coefficient) > **C44** (PID gain coefficient). To perform a reverse action, set **Pr.128 PID action selection** to forward action. Alternatively, to perform a forward action, set **Pr.128** to reverse action. In this case, the PID output shutoff release level is (1000 - **Pr.577**).

Pr.934 < Pr.935 (normal setting)		Pr.934 ≥ Pr.935	
Reverse action	Reverse action setting to Pr.128	Reverse action	Forward action setting to Pr.128
Forward action	Forward action setting to Pr.128	Forward action	Reverse action setting to Pr.128
PID output shutoff release level	Pr.577 - 1000	PID output shutoff release level	1000 - Pr.577

(Example) Set the following: **C42 (Pr.934)** = "500", **C43 (Pr.934)** = 20% (4 mA is applied), **C44 (Pr.935)** = "100", and **C45 (Pr.935)** = 100% (20 mA is applied).

When the set point = 400 and the measured value = 360, the deviation is +40 (>0), but the inverter recognizes the deviation as -10% (<0). Because of this, operation amount does not increase in the reverse operation setting.

The operation amount increases when the forward operation is set.

To perform PID output shutoff release at deviation of +40 or higher, set **Pr.577** = "960".

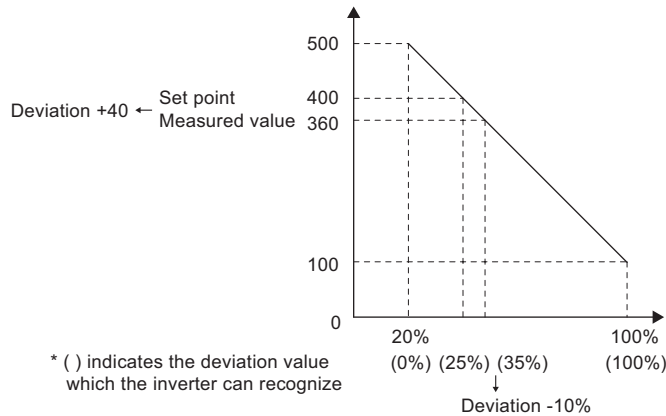

- The display of the following parameters is changed according to the **C42 (Pr.934)** and **C44 (Pr.935)** settings.

Pr.	Name
131	PID upper limit
132	PID lower limit
133	PID action set point
553	PID deviation limit
577	Output interruption cancel level

◆ Changing the PID display coefficient of the LCD operation panel (FR-LU08) or the parameter unit (FR-PU07) (Pr.759)

- Use **Pr.759 PID unit selection** to change the unit of the displayed value on the FR-LU08 or the FR-PU07.

For the coefficient set in **C42 (Pr.934) to C44 (Pr.935)**, the units can be changed as follows.

Pr.759 setting	Unit indication	Unit name
9999	%	%
0	—	(No indication)
1	K	Kelvin
2	C	Degree Celsius
3	F	Degree Fahrenheit
4	PSI	Pound-force per Square Inch
5	MPa	Mega Pascal
6	kPa	Kilo Pascal
7	Pa	Pascal
8	bar	Bar
9	mbr	Millibar
10	GPH	Gallon per Hour
11	GPM	Gallon per Minute
12	GPS	Gallon per Second
13	L/H	Liter per Hour
14	L/M	Liter per Minute
15	L/S	Liter per Second
16	CFH	Cubic Feet per Hour
17	CFM	Cubic Feet per Minute
18	CFS	Cubic Feet per Second
19	CMH	Cubic Meter per Hour
20	CMM	Cubic Meter per Minute

Pr.759 setting	Unit indication	Unit name
21	CMS	Cubic Meter per Second
22	ftM	Feet per Minute
23	ftS	Feet per Second
24	m/M	Meter per Minute
25	m/S	Meter per Second
26	lbH	Pound per Hour
27	lbM	Pound per Minute
28	lbS	Pound per Second
29	iWC	Inch of Water Column
30	iWG	Inch of Water Gauge
31	fWG	Feet of Water Gauge
32	mWG	Meter of Water Gauge
33	iHg	Inches of Mercury
34	mHg	Millimeters of Mercury
35	kgH	Kilogram per Hour
36	kgM	Kilogram per Minute
37	kgS	Kilogram per Second
38	ppm	Pulse per Minute
39	pps	Pulse per Second
40	kW	Kilowatt
41	hp	Horse Power
42	Hz	Hertz
43	rpm	Revolution per Minute

13.4 Dancer control

PID control is performed using detected dancer roll position as feedback data. The dancer roll is controlled to be at a designated position.

Pr.	Name	Initial value	Setting range	Description		
44 F020	Second acceleration/ deceleration time	5 s ^{*1}	0 to 3600 s	Set the acceleration/deceleration time during dancer control. In dancer control, this parameter becomes the acceleration/deceleration time of the main speed. This setting does not operate as the second acceleration/deceleration time.		
		10 s ^{*2}				
		15 s ^{*3}				
45 F021	Second deceleration time	9999	0 to 3600 s	Set the deceleration time during dancer control. In dancer control, this parameter becomes the deceleration time of the main speed. This setting does not operate as the second deceleration time.		
			9999	Pr.44 is the deceleration time.		
128 A610	PID action selection	0	0	No PID action		
			40	PID reverse action	Additive method: Fixed	For dancer control
			41	PID forward action	Additive method: Fixed	
			42	PID reverse action	Additive method: Ratio	
			43	PID forward action	Additive method: Ratio	
			Others	Refer to page 283 .		
129 A613	PID proportional band	100%	0.1% to 1000%	If a narrow proportional band is set (small parameter setting value), the manipulated amount changes considerably by slight changes in the measured value. As a result, response improves as the proportional band becomes narrower, though stability worsens as shown by the occurrence of hunting. Gain $K_p=1/\text{proportional band}$		
			9999	No proportional control		
130 A614	PID integral time	1 s	0.1 to 3600 s	With deviation step input, this is the time (Ti) used for obtaining the same manipulated amount as proportional band (P) by only integral (I) action. Arrival to the set point becomes quicker the shorter an integral time is set, though hunting is more likely to occur.		
			9999	No integral control		
131 A601	PID upper limit	9999	0% to 100%	Set the upper limit. The FUP signal is output when the feedback value exceeds this setting. The maximum input (20 mA/5 V/10 V) of the measured value (terminal 4) is equivalent to 100%.		
			9999	No function		
132 A602	PID lower limit	9999	0% to 100%	Set the lower limit. The FDN signal is output when the measured value (terminal 4) falls below the setting range. The maximum input (20 mA/5 V/10 V) of the measured value is equivalent to 100%.		
			9999	No function		
133 A611	PID action set point	9999	0% to 100%	Set the set point during PID control.		
			9999	Input of set point by terminal selected by Pr.609		
134 A615	PID differential time	9999	0.01 to 10 s	With deviation ramp input, this is the time (Td) used for obtaining the manipulated amount only by proportional action (P). Response to changes in deviation increase greatly as the differential time increases.		
			9999	No differential control		
609 A624	PID set point/deviation input selection	2	2	The set point is input through terminal 2.		
			3	The set point is input through terminal 4.		
610 A625	PID measured value input selection	3	2	The measured value is input through terminal 2.		
			3	The measured value is input through terminal 4.		

*1 Initial value for the FR-D820-3.7K-165 or lower, the FR-D840-3.7K-081 or lower, the FR-D820S-2.2K-100 or lower, and the FR-D810W-0.75K-042 or lower.

*2 Initial value for the FR-D820-5.5K-238, FR-D820-7.5K-318, FR-D840-5.5K-120, and FR-D840-7.5K-163.

*3 Initial value for the FR-D820-11K-450 or higher and the FR-D840-11K-230 or higher.

◆ Block diagram of dancer control

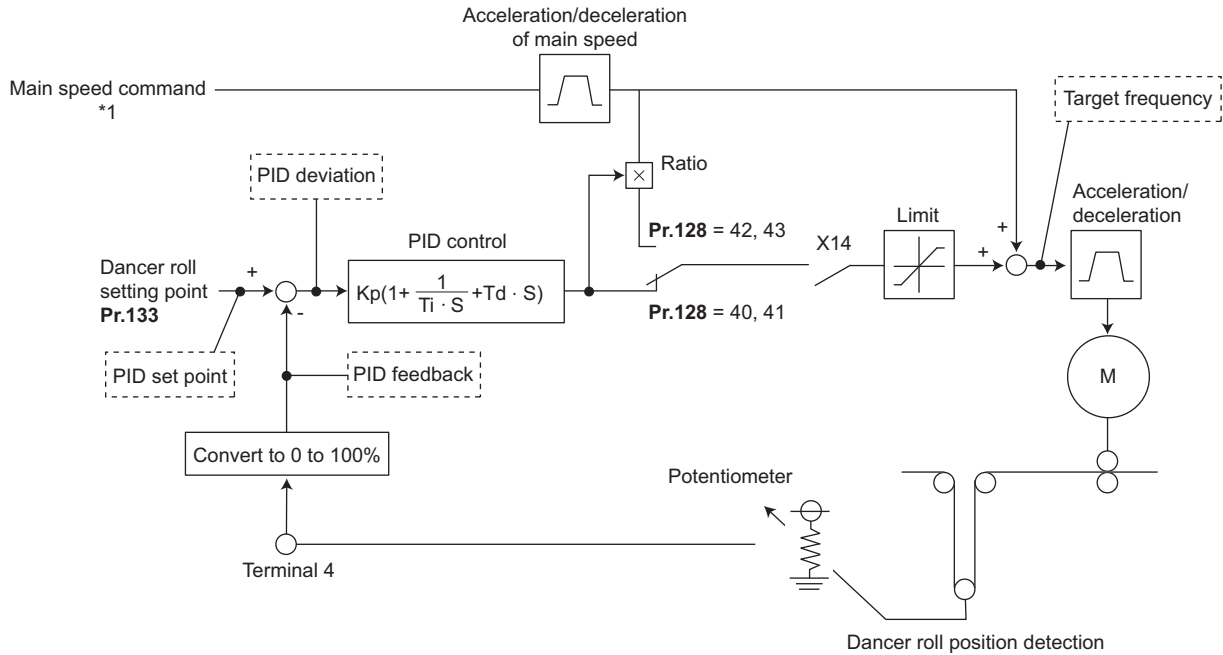

*1 The main speed can be selected in all operation modes, External (analog voltage input, multi-speed), PU (digital frequency setting) and Communication.

◆ Outline of dancer control

- Dancer control is performed by setting "40 to 43" in **Pr.128 PID action selection**. The main speed command is the speed command for each operation mode (External, PU, and communication). PID control is performed by the dancer roll position detection signal, and the control result is added to the main speed command. For the main speed acceleration/deceleration time, set the acceleration time to **Pr.44 Second acceleration/deceleration time** and the deceleration time to **Pr.45 Second deceleration time**.

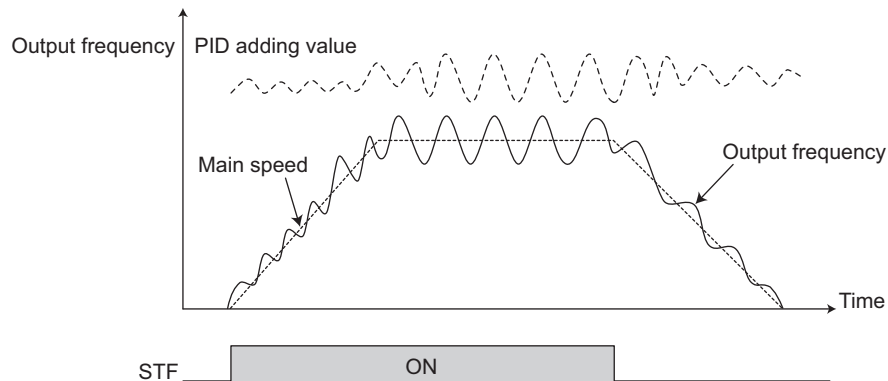

NOTE

- Normally, set **Pr.7 Acceleration time** and **Pr.8 Deceleration time** to 0 s. When the **Pr.7** and **Pr.8** settings are large, dancer control response becomes slow during acceleration/deceleration.
- If an automatic restart after instantaneous power failure is activated during dancer control, E.OC[] or E.OV[] is likely to occur. In such case, disable the automatic restart after instantaneous power failure function (**Pr.57** = "9999").

◆ Connection diagram

- Sink logic
- **Pr.128** = "41"
- **Pr.182** = "14"
- **Pr.190** = "14"
- **Pr.191** = "15"
- **Pr.133** = Set point

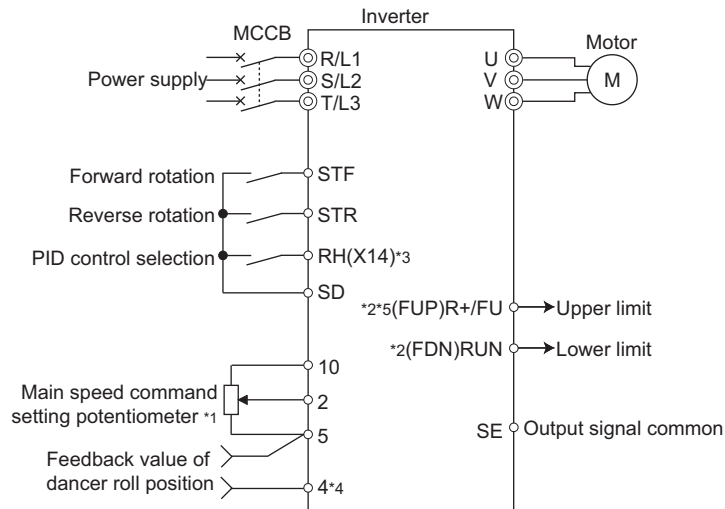

- *1 The main speed command differs according to each operation mode (External, PU, communication).
 *2 The applied output terminals differ by the settings of **Pr.190 to Pr.196 (Output terminal function selection)**.
 *3 The applied input terminals differ by the settings of **Pr.178 to Pr.182 and Pr.185 to Pr.189 (Input terminal function selection)**.
 *4 The AU signal need not be input.
 *5 When the R+/FU switch (SW5) is set to the upper position (FU) (initial status), the assigned function is enabled. Assignment is not available when the RS-485 terminal is used for RS-485 communication. For details, refer to the Instruction Manual (Connection) and the Instruction Manual (Communication).

◆ Dancer control operation selection (Pr.128)

Pr.128 setting	PID action	Additive method	Set point input	Measured value input
0	PID invalid	—	—	—
40	Reverse action	Fixed	Set by Pr.133 or input by terminal selected by Pr.609 ^{*1}	Input by terminal selected by Pr.610
41	Forward action			
42	Reverse action	Ratio		
43	Forward action			
Others	Refer to page 283 .			

*1 When **Pr.133** ≠ "9999", the **Pr.133** setting is valid.

- To enable dancer control, set "40 to 43" in **Pr.128 PID action selection**.
- Dancer control is enabled only when the PID control valid (X14) signal turns ON when "14" is set in any parameter from **Pr.178 to Pr.182 and Pr.185 to Pr.189 (Input terminal function selection)** and X14 signal is assigned. When the X14 signal is not assigned, dancer control is enabled only by the **Pr.128** setting.
- Input the main speed command (External, PU, Communication). Dancer control is also supported by the main speed command in all operation modes.
- Input the set point between the terminals 2 and 5 (the setting can be selected using **Pr.133** or **Pr.609**) and input the measured value signal (dancer roll position detection signal) between the inverter terminals 4 and 5 (the setting can be selected using **Pr.610**).
- The action of **Pr.129 PID proportional band**, **Pr.130 PID integral time**, **Pr.131 PID upper limit**, **Pr.132 PID lower limit** and **Pr.134 PID differential time** is the same as PID control action. In the relationship between the control amount (%) and frequency in PID control, 0% is equivalent to the frequencies set in **C2 (Pr.902)** and 100% is equivalent to the frequencies set in **Pr.125**.

NOTE

- When **Pr.128** is set to "0" or the X14 signal is OFF, regular inverter running not dancer control is performed.
- Dancer control is enabled by turning ON/OFF the bits of terminals assigned the X14 signal by RS-485 communication or over the network.
- When dancer control is selected, set the PID output suspension function (**Pr.575 Output interruption detection time** = "9999").
- When **Pr.561 PTC thermistor protection level** ≠ "9999", terminal 2 cannot be used for the main speed command. Terminal 2 becomes the PTC thermistor input terminal.

◆ Selection of set point/measured value input method (Pr.609, Pr.610)

- Select the set point input method by **Pr.609 PID set point/deviation input selection** and the measured value input method by **Pr.610 PID measured value input selection**. Switch the power voltage/current specifications of terminals 2 and 4 by **Pr.73 Analog input selection** or **Pr.267 Terminal 4 input selection** to match the specification of the input device.
- When **Pr.133 PID action set point** ≠ "9999", **Pr.133** is the set point. When the set point is set at **Pr.133**, the setting frequency of **C2 (Pr.902)** is equivalent to 0% and the setting frequency of **Pr.125** is equivalent to 100%.

Pr.609 and Pr.610 settings	Input method
2	Terminal 2 ^{*1}
3	Terminal 4 ^{*1}

*1 When the same input method has been selected for the set point and measured value at **Pr.609** and **Pr.610**, set point input is invalid. (Inverter runs at set point 0%)

NOTE

- After changing the **Pr.73** or **Pr.267** setting, check the voltage/current input switch. Incorrect setting may cause a fault, failure or malfunction. (Refer to [page 243](#) for the setting.)
- When terminals 2 and 4 are selected for deviation input, perform bias calibration using **C3 (Pr.902)** and **C6 (Pr.904)** to prevent a minus voltage from being entered as the deviation input signal. Input of a minus voltage might damage devices and the inverter.

- The following shows the relationship between the input values of the analog input terminals, and the set point and measured value.

Input terminal	Input specification ^{*2}	Relationship with analog input		Calibration parameter
		Set point	Result	
Terminal 2	0 to 5 V	0 V = 0% 5 V = 100%	0 V = 0% 5 V = 100%	Pr.125, C2 to C4 (Pr.902, Pr.903)
	0 to 10 V	0 V = 0% 10 V = 100%	0 V = 0% 10 V = 100%	
	0 to 20 mA	0 mA = 0% 20 mA = 100%	0 mA = 0% 20 mA = 100%	
Terminal 4	0 to 5 V	0 to 1 V = 0% 5 V = 100%	0 to 1 V = 0% 5 V = 100%	Pr.126, C5 to C7 (Pr.904, Pr.905)
	0 to 10 V	0 to 2 V = 0% 10 V = 100%	0 to 2 V = 0% 10 V = 100%	
	0 to 20 mA	0 to 4 mA = 0% 20 mA = 100%	0 to 4 mA = 0% 20 mA = 100%	

*2 Can be changed by **Pr.73** and **Pr.267** and the voltage/current input switch. (Refer to [page 243](#).)

◆ Selection of additive method for PID calculation result

- When ratio is selected as the additive method (**Pr.128** = "42, 43"), PID calculation result × (ratio of main speed) is added to the main speed. The ratio is determined by the **Pr.125 Terminal 2 frequency setting gain frequency and C2 (Pr.902) Terminal 2 frequency setting bias frequency** settings. In the initial status, 0 to 60 Hz is set for 0% to 100%. Thus, 60 Hz main speed is regarded as 100%, and the 30 Hz main speed is regarded as 50%.

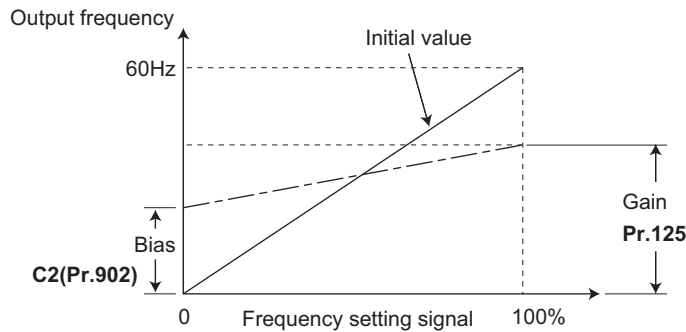

NOTE

- Even if **C4 (Pr.903)** is set to other than 100%, the frequency setting signal is treated as 100%.
- Even if **C3 (Pr.902)** is set to other than 0%, the frequency setting signal is treated as 0%.
- If **C2 (Pr.902)** is set to other than 0 Hz, the frequency setting signal is 0% at the **C2 (Pr.902)** frequency setting or below.

◆ Input/output signals

- The following signals can be used by assigning functions to **Pr.178 to Pr.182 and Pr.185 to Pr.189 (Input terminal function selection)** and **Pr.190 to Pr.196 (Output terminal function selection)**.
- Input signal

Signal	Function	Pr.178 to Pr.182, Pr.185 to Pr.189 setting	Description
X14	PID control valid	14	When this signal is assigned to the input terminal, PID control is enabled when this signal is ON.
X72	PID P control switchover	72	Only proportional term is valid when this signal is turned ON. (Integral and differential values are reset.)

- Output signal

Signal	Function	Pr.190 to Pr.196 settings		Description
		Positive logic	Negative logic	
FUP	PID upper limit	15	115	Output when the measured value signal exceeds Pr.131 PID upper limit .
FDN	PID lower limit	14	114	Output when the measured value signal falls below Pr.132 PID lower limit .
RL	PID forward/ reverse rotation output	16	116	"Hi" is output when the output display of the operation panel is forward rotation (the RUN LED is ON) and "Low" is output when the display is reverse rotation (the RUN LED blinks) and stop (the RUN LED is OFF). "Hi" is output when the output display of the parameter unit is forward rotation (FWD) and "Low" is output when the display is reverse rotation (REV) and stop (STOP).
PID	During PID control activated	47	147	Turns ON during PID control.

NOTE

- Changing the terminal functions with **Pr.178 to Pr.182, Pr.185 to Pr.189, and Pr.190 to Pr.196** may affect other functions. Set parameters after confirming the function of each terminal.

◆ PID monitor function

- This function displays the PID control set point and measured value on the operation panel, and can output these from terminal AM.
- Set the following values to **Pr.52 Operation panel main monitor selection**, **Pr.774 to Pr.776 (Operation panel monitor selection)**, **Pr.992 Operation panel setting dial push monitor selection**, and **Pr.158 AM terminal function selection** for each monitor.

Parameter setting	Monitor description	Minimum increment	Monitor range		Remarks
			Terminal AM	Operation panel	
97	Dancer main set speed	0.01 Hz	0 to 590 Hz		When outputting through terminal AM, the full scale value can be adjusted by Pr.55 Frequency monitoring reference .

NOTE

- Refer to [page 292](#) for details on other PID control monitors.

◆ Priority of main speed commands

- The priority of the frequency command given by the external signals is as follows: JOG operation (JOG/JOG2 signal) > multi-speed operation (RL/RM/RH/REX signal) > PID control (X14 signal) > terminal 4 analog input (AU signal) > pulse train input > terminal 2 analog input.
- The following is the frequency commands listed in descending order of priority when "3" is set in **Pr.79 Operation mode selection**: Multi-speed setting function (RL/RM/RH/REX signal) > PID control (X14 signal) > terminal 4 analog input (AU signal) > set frequency (digital input from the PU).
- Even if the remote operation function is selected by **Pr.59 Remote function selection** ≠ "0", compensation of the remote setting frequency against the main speed is ignored. (The value is "0".)
- If the same terminal as an external input terminal having a speed command source (external terminal where a main speed is input) is specified as the measured value input or set point input, the main speed is treated as "0".
- Setting **Pr.73** ≥ 10 enables the polarity reversible operation when the PID manipulated amount is added to the main speed command. (Polarity reversible operation of the main speed command without addition is not possible.)

◆ Adjustment procedure for dancer roll position detection signal

- When the input of terminal 4 is voltage input, 0 V is the lower limit position and 5 V (10 V) is the upper limit position (initial values). When it is current input, 4 mA is the lower limit position and 20 mA is the upper limit position (initial values). When the potentiometer has an output of 0 to 7 V, **C7 (Pr.905)** must be calibrated at 7 V.

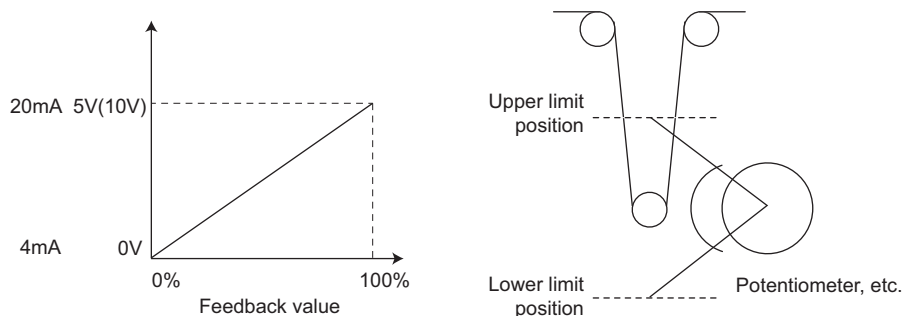

(Example) To execute control at the dancer center position using a 0 to 7 V potentiometer

1. Switch the voltage/current input switch (switch 4) to "V", set "2" in **Pr.267**, and set terminal 4 input to voltage input.
2. Input 0 V across terminals 4 and 5, and calibrate **C6 (Pr.904)**. (The % display that is indicated at analog calibration is not related to the % of the feedback value.)
3. Input 7 V across terminals 4 and 5, and calibrate **C7 (Pr.905)**. (The % display that is indicated at analog calibration is not related to the % of the feedback value.)
4. Set **Pr.133** to "50%".

NOTE

- After changing the **Pr.267** setting, check the voltage/current input switch. Incorrect setting may cause a fault, failure or malfunction. (Refer to [page 243](#) for the setting.)
- If the Multi-speed operation (RH, RM, RL, or REX) signal, or JOG signal is input during regular PID control, PID control is interrupted. However, at dancer control, these signals are treated as main speed commands, so PID control is continued.
- During dancer control, **Pr.44 and Pr.45** (Second acceleration/deceleration time) is the parameter for setting the acceleration/deceleration time for the main speed command. This function does not work as a second function.
- When the switchover mode is set by setting "6" to **Pr.79**, dancer control (PID control) is invalid.
- The acceleration/deceleration action of the main speed command is the same as that when the frequency is increased or decreased by analog input. The SU signal sometimes stays ON even if operation is turned ON/OFF by the start signal. The set frequency monitor is the value "main speed command + PID control" which is constantly changing.
- With the main speed setting frequency setting, acceleration/deceleration is performed for the acceleration/deceleration time set in **Pr.44 and Pr.45**, and with the output frequency setting, acceleration/deceleration is performed for the acceleration/deceleration time set in **Pr.7 and Pr.8**. For this reason, with the output frequency, when the time set in **Pr.7 and Pr.8** is longer than the time set in **Pr.44 and Pr.45**, acceleration/deceleration is performed for the acceleration/deceleration time set in **Pr.7 and Pr.8**.
- The limit of the integral term is the smaller of 100% and the value after conversion of the straight line after interpolation of **Pr.1 Maximum frequency** by **C2 (Pr.902) and Pr.125** to the PID manipulated amount.
However, note that the lower limit frequency limits the output frequency, but does not restrict the action of the integral item.

Parameters referred to

Pr.57 Restart coasting time [page 307](#)

Pr.59 Remote function selection [page 135](#)

Pr.73 Analog input selection [page 243](#)

Pr.79 Operation mode selection [page 142](#)

Pr.178 to Pr.182 and Pr.185 to Pr.189 (Input terminal function selection) [page 252](#)

Pr.190 to Pr.196 (Output terminal function selection) [page 226](#)

Pr.561 PTC thermistor protection level [page 166](#)

C2 (Pr.902) to C7 (Pr.905) Frequency setting voltage (current) bias/gain [page 248](#)

13.5 Automatic restart after instantaneous power failure / flying start with an induction motor



The inverter can be restarted without stopping the motor operation in the following situations:

- When an instantaneous power failure occurs during inverter running
- When the motor is coasting at start

Pr.	Name	Initial value	Setting range	Description
162 A700	Automatic restart after instantaneous power failure selection	0	0	Frequency search only performed at the first start
			1	Reduced voltage start only at the first start (no frequency search)
			10	Frequency search at every start
			11	Reduced voltage start at every start (no frequency search)
299 A701	Rotation direction detection selection at restarting	0	0	Rotation direction detection disabled
			1	Rotation direction detection enabled
			9999	When Pr.78 Reverse rotation prevention selection = "0", rotation direction detection enabled. When Pr.78 Reverse rotation prevention selection = "1 or 2", rotation direction detection disabled.
57 A702	Restart coasting time	9999	0	Coasting time differs according to the inverter capacity.*1
			0.1 to 30 s	Set the time delay for the inverter to perform a restart after restoring power due to an instantaneous power failure.
			9999	No restart
58 A703	Restart cushion time	1 s	0 to 60 s	Set the voltage cushion time for restart.
165 A710	Stall prevention operation level for restart	150%	0% to 400%	Set the stall prevention level at restart operation on the assumption that the inverter rated current is 100%.
611 F003	Acceleration time at a restart	9999	0 to 3600 s	Set the acceleration time to reach Pr.20 Acceleration/deceleration reference frequency at restart.
			9999	Standard acceleration time (for example, Pr.7) is applied as the acceleration time at restart.

*1 The coasting time when **Pr.57** = "0" is as follows. (When **Pr.162** and **Pr.570** are set to the initial value.)
 1 s for the FR-D820-1.5K-070 or lower, the FR-D840-1.5K-037 or lower, the FR-D820S-1.5K-070 or lower, and the FR-D810W-0.75K-042 or lower
 2 s for the FR-D820-2.2K-100 to FR-D820-7.5K-318, FR-D840-2.2K-050 to FR-D840-7.5K-163, and FR-D820S-2.2K-100
 3 s for the FR-D820-11K-450 or higher and the FR-D840-11K-230 or higher

Point

- To operate the inverter with the automatic restart after instantaneous power failure function enabled, check the following points.
- Set **Pr.57 Restart coasting time** = "0".

◆ Setting for the automatic restart after instantaneous power failure operation (Pr.162)

- The **Pr.162** settings and the instantaneous power failure automatic restart operation under each operation mode are as shown in the following table.

Pr.162 setting	Restart timing	Instantaneous power failure automatic restart operation
0 (initial value)	At first start	Frequency search
1		Reduced voltage start
10	At every start	Frequency search
11		Reduced voltage start

NOTE

- The wiring distance must be 100 m or less when the frequency search is performed.
- The frequency search is available at a frequency from 6 to 120 Hz for the 100/200 V class, and from 15 to 120 Hz for the 400 V class. (The motor capacity must be the same or one rank lower than the inverter capacity.)

◆ Restart operation with frequency search (Pr.162 = "0 or 10", Pr.299)

- When **Pr.162** = "0 (initial value) or 10", the motor speed is detected at a power restoration so that the motor can re-start smoothly.
- The encoder also detects the rotation direction so that the inverter can re-start smoothly even during the reverse rotation.
- Whether or not to detect the rotation direction can be selected by **Pr.299 Rotation direction detection selection at restarting**. If the motor capacity is different from the inverter capacity, set **Pr.299** = "0" (no rotation direction detection).
- When the rotation direction is detected, the following operation is performed according to **Pr.78 Reverse rotation prevention selection** setting.

Pr.299 setting	Pr.78 setting		
	0	1	2
9999	○	×	×
0 (initial value)	×	×	×
1	○	○	○

○: With rotation direction detection ×: Without rotation direction detection

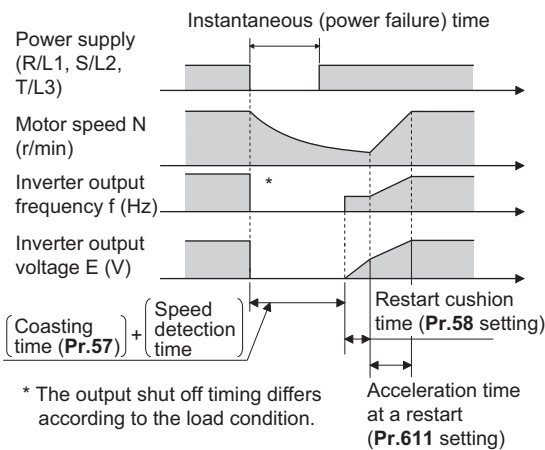

NOTE

- The rotation speed detection time (frequency search) changes according to the rotation speed of the motor (maximum 1 second).
- When the inverter capacity is two ranks or more higher than the motor capacity, the overcurrent protective function (E.OC[]) is sometimes activated and prevents the inverter from restarting.
- If two or more motors are connected to one inverter, this function operates abnormally. (The inverter does not restart successfully.)
- Because a DC injection brake is applied instantaneously at speed detection during a restart, the speed might drop if the moment of inertia (J) of the load is small.
- If reverse operation is detected when "1" (reverse rotation disabled) is set to **Pr.78**, operation decelerates by reverse rotation and then changes to forward rotation when the start command is forward rotation. The inverter does not restart when the start command is reverse rotation.
- When the automatic restart after instantaneous power failure is performed while the motor rotates at low speed (lower than 10 Hz), the motor rotates in the same direction as that before instantaneous power failure without detecting the rotation direction (even when **Pr.299** = "1").

◆ Restart operation without frequency search (Pr.162 = "1 or 11")

- When **Pr.162** = "1 or 11", reduced voltage start is used for the restart operation. In this method, the voltage is raised gradually while keeping the output frequency level at the level before an instantaneous power failure, regardless of the motor's coasting speed.

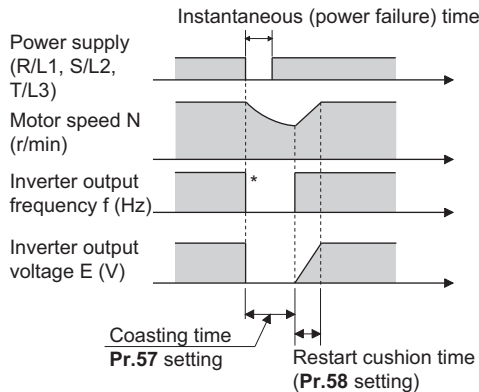

* The output shut off timing differs according to the load condition.

NOTE

- This restart method uses the output frequency that was active before the instantaneous power failure stored in memory. If the instantaneous power failure time is 0.2 second or more, the output frequency can no longer be stored and held in memory, so the restart is performed from **Pr.13 Starting frequency** (initial value: 0.5 Hz).

◆ Restart at every start (Pr.162 = "10 or 11")

- When "10 or 11" is set in **Pr.162**, a restart operation is performed at each start and automatic restart after instantaneous power failure (after the time period set in **Pr.57** elapsed). When "0 (initial value) or 1" is set in **Pr.162**, a restart operation is performed at the first start after a power-ON, and from the second power-ON onwards, a start from the starting frequency is performed.

◆ Automatic restart operation of the MRS (X10) signal

- The restart operation after restoration from output shutoff by the MRS (X10) signal is as shown in the following table according to the **Pr.30** setting.

Pr.30 setting	Operation after restoration from output shutoff by the MRS (X10) signal
2	Restart operation (starting from the coasting speed)
Other than the above	Starting from Pr.13 Starting frequency .

NOTE

- When output is shut off using safety stop function (terminals S1 and S2), the inverter restarts in the same way as when output is shut off by the MRS (X10) signal.
- Operation is selectable as shown in the table above when **Pr.162 Automatic restart after instantaneous power failure selection** = "0 or 1". When **Pr.162** = "10 or 11" (automatic restart operation at each start), a restart operation is performed regardless of the setting of **Pr.30 Regenerative function selection**.
- Set "24" in any parameter from **Pr.178 to Pr.182 and Pr.185 to Pr.189 (Input terminal function selection)** to assign the Output stop (MRS) signal to the input terminal, and "10" to assign the Inverter run enable (X10) signal.

◆ Adjustment of restart coasting time (Pr.57)

- Restart coasting time is the time period from the occurrence of instantaneous power failure until the operation is restarted after power is restored.

With frequency search, the motor speed is detected and operation is restarted after the coasting time.

- To enable restart operation, set "0" in **Pr.57 Restart coasting time**. If "0" is set to **Pr.57**, the coasting time is automatically set to the following number of seconds. Generally, this setting does not interfere with inverter operation.

Voltage class	Inverter		Coasting time (s)
	ND	SLD	
100 V	FR-D810W-0.75K-042 or lower	—	1
200 V	FR-D820-1.5K-070 or lower FR-D820S-1.5K-070 or lower	FR-D820-0.75K-042 or lower	1
	FR-D820-2.2K-100 to FR-D820-7.5K-318 FR-D820S-2.2K-100	FR-D820-1.5K-070 to FR-D820-5.5K-238	2
	FR-D820-11K-450 or higher	FR-D820-7.5K-318 or higher	3
400 V	FR-D840-1.5K-037 or lower	FR-D840-0.75K-022 or lower	1
	FR-D840-2.2K-050 to FR-D840-7.5K-163	FR-D840-1.5K-037 to FR-D840-5.5K-120	2
	FR-D840-11K-230 or higher	FR-D840-7.5K-163 or higher	3

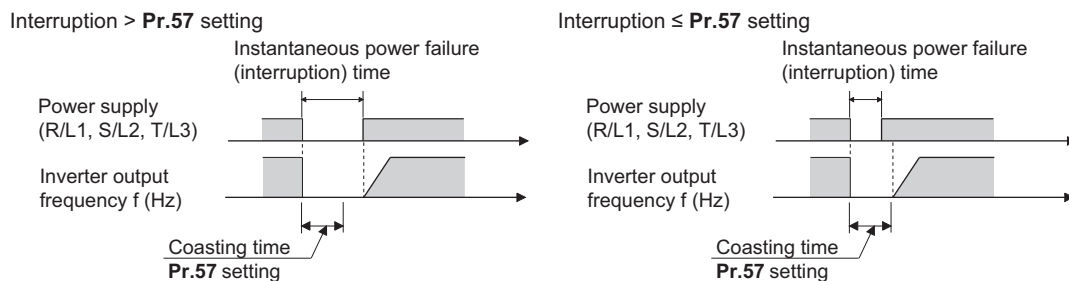

- Inverter operation is sometimes hindered by the size of the moment of inertia (J) of the load, output frequency, or the residual magnetic flux in the motor. Adjust this coasting time within the range 0.1 to 30 seconds to match the load specification.

◆ Restart cushion time (Pr.58)

- The cushion time is the time taken to raise the voltage to the level required for the specified speed after the motor speed detection (output frequency before the instantaneous power failure when **Pr.162** = "1 or 11").
- Normally, the motor runs at the initial value as it is. However, adjust to suit the moment of inertia (J) of the load or the size of the torque.

◆ Adjustment of restart operation (Pr.165, Pr.611)

- The stall prevention operation level at a restart operation can be set in **Pr.165**.
- Using **Pr.611**, the acceleration time to reach **Pr.20 Acceleration/deceleration reference frequency** after a restart operation can be set. This can be set individually from the normal acceleration time.

NOTE

- Changing the terminal assignment using **Pr.178 to Pr.182** and **Pr.185 to Pr.189 (Input terminal function selection)** may affect the other functions. Set parameters after confirming the function of each terminal.
- The SU and FU signals are not output during the restart. These signals are output after the restart cushion time passes.
- Restart operation is also performed after the inverter reset is released or after the retry by the retry function occurs.

CAUTION

- When the automatic restart after instantaneous power failure function is selected, the motor suddenly starts (after reset time passes) when an instantaneous power failure occurs. Stay away from the motor and machinery. When the automatic restart after instantaneous power failure function has been selected, apply the CAUTION sticker(s), which are found in the Instruction Manual (Connection), to easily visible places.

« Parameters referred to »

Pr.7 Acceleration time  [page 130](#)

Pr.13 Starting frequency  [page 139](#), [page 141](#)

Pr.65, Pr.67 to Pr.69 Retry function  [page 179](#)

Pr.78 Reverse rotation prevention selection  [page 158](#)

Pr.178 to Pr.182 and Pr.185 to Pr.189 (Input terminal function selection)  [page 252](#)

13.6 Automatic restart after instantaneous power failure / flying start with a PM motor

PM

The inverter can be restarted without stopping the motor operation.

When the automatic restart after instantaneous power failure function is selected, the motor driving is resumed in the following situations:

- When power comes back ON during inverter driving after an instantaneous power failure
- When the motor is coasting at start

Pr.	Name	Initial value	Setting range	Description
57 A702	Restart coasting time	9999	0	No delay
			0.1 to 30 s	Set the delay time for the inverter to perform a restart after restoring power due to an instantaneous power failure.
			9999	No restart
162 A700	Automatic restart after instantaneous power failure selection	0	0, 1	Frequency search only performed at the first start
			10, 11	Frequency search at every start
611 F003	Acceleration time at a restart	9999	0 to 3600 s	Set the acceleration time to reach Pr.20 Acceleration/deceleration reference frequency at restart.
			9999	Standard acceleration time (for example, Pr.7) is applied as the acceleration time at restart.

◆ Selection of restart operation (Pr.162)

- At a power restoration, the encoder detects the motor speed by a frequency search so that the inverter can re-start smoothly.
- The encoder also detects the rotation direction so that the inverter can re-start smoothly even during the reverse rotation.
- When "10 (or 11)" is set in **Pr.162**, a restart operation is performed at each start and automatic restart after instantaneous power failure. When "0 (or 1)" is set in **Pr.162**, a restart operation is performed at the first start after a power-ON, and from the second power-ON onwards, a start from the starting frequency is performed.

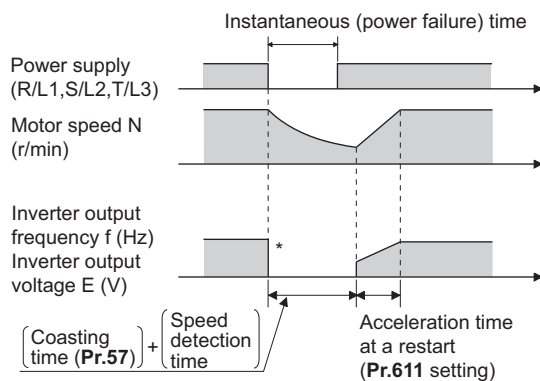

NOTE

- The wiring length should be 30 m at maximum.
- When the EM-A motor is used, the frequency search is available at a frequency from 15% of the rated motor frequency to the maximum motor frequency.
- Because a DC injection brake is applied instantaneously at speed detection during a restart, the speed might drop if the moment of inertia (J) of the load is small.
- Restart operation with reduced voltage is not available for PM sensorless vector control.
- A protective function may be activated for some motor models or at certain running speeds, disabling restarting.

◆ Restart coasting time (Pr.57)

- Coasting time is the time from the motor speed detection to the restart operation start.
- To enable restart operation, set "0" (no coasting time) in **Pr.57 Restart coasting time**. Generally, this setting does not interfere with inverter operation.
- Inverter operation is sometimes hindered by the size of the moment of inertia (J) of the load or the output frequency. Adjust this coasting time within the range 0.1 to 30 seconds to match the load specification.

◆ Adjustment of restart operation (Pr.611)

- Using **Pr.611**, the acceleration time to reach **Pr.20 Acceleration/deceleration reference frequency** after a restart operation can be set. This can be set individually from the normal acceleration time.

NOTE

- A PM motor is a motor with interior permanent magnets. Regressive voltage is generated when the motor coasts at an instantaneous power failure or at a flying start. The inverter's DC bus voltage rises if the motor coasts fast or makes a flying start in this condition.
When using the automatic restart after instantaneous power failure function (**Pr.57** ≠ "9999"), it is recommended to also use the regenerative avoidance function (**Pr.882 Regeneration avoidance operation selection** = "1") to make startups stable. If the overvoltage protective function (E.OV[]) still occurs with the regeneration avoidance function, also use the retry function (**Pr.67**).
- When a built-in brake or a regeneration unit is used, the frequency search may not be available while the motor speed is equal to or higher than the motor rated speed plus 10%. The restart operation cannot be performed until the motor speed drops to a frequency where the frequency search is available.

⚠ CAUTION

- A PM motor is a motor with interior permanent magnets. High voltage is generated at motor terminals while the motor is running. Do not touch motor terminals and other parts until the motor stops to prevent an electric shock.
- When the automatic restart after instantaneous power failure function is selected, the motor suddenly starts (after reset time passes) when an instantaneous power failure occurs.
Stay away from the motor and machinery.
When the automatic restart after instantaneous power failure function has been selected, apply the CAUTION sticker(s), which are found in the Instruction Manual (Connection), to easily visible places.

Parameters referred to

Pr.13 Starting frequency  [page 139](#), [page 141](#)

Pr.65, Pr.67 to Pr.69 Retry function  [page 179](#)

Pr.78 Reverse rotation prevention selection  [page 158](#)

Pr.882 Regeneration avoidance operation selection  [page 345](#)

13.7 Offline auto tuning for a frequency search



Under V/F control, the accuracy of the "frequency search", which is used to detect the motor speed for the automatic restart after instantaneous power failure and flying start, can be improved.

Pr.	Name	Initial value	Setting range	Description
162 A700	Automatic restart after instantaneous power failure selection	0	0	Frequency search only performed at the first start
			1	Reduced voltage start only at the first start (no frequency search)
			10	Frequency search at every start
			11	Reduced voltage start at every start (no frequency search)
298 A711	Frequency search gain	9999	0 to 32767	The offline auto tuning automatically sets the gain required for the frequency search.
			9999	The constant value of Mitsubishi Electric motor (SF-PR, SF-JR, SF-HR, SF-JRCA, or SF-HRCA) is used.
96 C110	Auto tuning setting/status	0	0	No offline auto tuning
			1	Offline auto tuning is performed under Advanced magnetic flux vector control or PM sensorless vector control. (Refer to page 266 and page 274 .)
			11	Offline auto tuning is performed without the motor rotating (under V/F control).
90 C120	Motor constant (R1)	9999	0 to 50 Ω, 9999	Tuning data (The value measured by offline auto tuning is automatically set.) 9999: The constant value of Mitsubishi Electric motor (SF-PR, SF-JR, SF-HR, SF-JRCA, or SF-HRCA) is used.

◆ Offline auto tuning for a frequency search

- When the frequency search is selected by setting **Pr.162 Automatic restart after instantaneous power failure selection** = "0 or 10", perform offline auto tuning.

◆ Before performing offline auto tuning

Check the following points before performing offline auto tuning:

- V/F control is selected.
- Check that a motor is connected. (Check that the motor is not rotated by an external force during tuning.)
- The rated motor current should be equal to or less than the inverter rated current.
If a motor with substantially low rated current compared with the inverter rated current is used, speed accuracy may deteriorate due to torque ripples, etc. Set the rated motor current to about 40% or higher of the inverter rated current. (For details on the inverter rated current, refer to the inverter rated specifications in the Instruction Manual (Connection).)
- The target motor is other than a high-slip motor, a high-speed motor, or a special motor.
- The motor may rotate slightly even if the offline auto tuning without the motor rotating (**Pr.96 Auto tuning setting/status** = "11") is selected. Fix the motor securely with a mechanical brake, or before tuning, make sure that it is safe even if the motor rotates. (Caution is required especially in vertical lift applications.) Note that even if the motor runs slightly, tuning performance is unaffected.
- Offline auto tuning is not performed correctly when the surge voltage suppression filter (FR-ASF-H/FR-BMF-H) is inserted between the inverter and motor. Be sure to remove them before performing tuning.

◆ Setting

1. Set "11" in **Pr.96 Auto tuning setting/status**.
2. Set the rated motor current (initial value is the inverter rated current) in **Pr.9 Electronic thermal O/L relay**. (Refer to [page 166](#).)
3. Set **Pr.71 Applied motor** according to the motor to be used.

Motor		Pr.71 setting
Mitsubishi Electric standard efficiency motor Mitsubishi Electric high-efficiency motor	SF-JR	0 (3)
	SF-JR 4P 1.5 kW or lower	20 (23)
	SF-HR	40 (43)
	Others	0 (3)
Mitsubishi Electric constant-torque motor	SF-JRCA 4P	10 (13)
	SF-HRCA	50 (53)
	Others (SF-JRC, etc.)	10 (13)
Mitsubishi Electric high-performance energy-saving motor	SF-PR	70 (73)
Other manufacturer's standard motor	—	0 (3)
Other manufacturer's constant-torque motor	—	10 (13)

◆ Performing tuning





Point

- Before performing tuning, check the monitor display of the operation panel or parameter unit if the inverter is in the state ready for tuning. The motor starts by turning ON the start command while tuning is unavailable.
- In the PU operation mode, press the RUN key on the operation panel or the FWD/REV key on the parameter unit. In the External operation, turn ON the start command (STF signal or STR signal). Tuning starts. (At this time, excitation noise occurs.)

NOTE

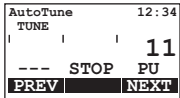
- It takes about 10 seconds for tuning to complete. (The time depends on the inverter capacity and motor type.)
- Satisfy the required inverter start conditions to start offline auto tuning. For example, stop the input of the MRS signal.
- To force tuning to end, use the MRS or RES signal or the STOP/RESET key on the PU. (Turning OFF the start signal (STF signal or STR signal) also ends tuning.)
- During offline auto tuning, only the following I/O signals are valid (initial value).
Input terminals <effective signals>: MRS, RES, STF, STR, S1, and S2
Output terminals: RUN, AM, ABC, and SO
- When the rotation speed and the output frequency are selected for terminal AM, the progress status of offline auto tuning is output in 15 steps from AM.
- Do not perform ON/OFF switching of the Second function selection (RT) signal during offline auto tuning. Auto tuning will not be performed properly.
- Since the RUN signal turns ON when tuning is started, pay close attention especially when a sequence which releases a mechanical brake by the RUN signal has been designed.
- When executing offline auto tuning, input the operation command after switching ON the main circuit power (R/L1, S/L2, T/L3) of the inverter.
- While **Pr.79 Operation mode selection** = "7", turn ON the PU operation external interlock (X12) signal for tuning in the PU operation mode.

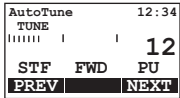
- The tuning status (**Pr.96** setting value) is displayed on the operation panel.

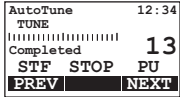
Status	Operation panel indication	LCD operation panel (FR-LU08) display
Setting		
Tuning in progress		
Normal end		

- When offline auto tuning ends, press the STOP/RESET key on the PU during PU operation. For External operation, turn OFF the start signal (STF signal or STR signal). This operation resets the offline auto tuning, and the monitor display of the operation panel returns to normal. (Without this operation, next operation cannot be started.)
- At tuning completion, the tuning results are set in the following parameters:

Pr.	Name
90	Motor constant (R1)
298	Frequency search gain
96	Auto tuning setting/status

NOTE

- The motor constants measured once during offline auto tuning are stored as parameters and their data are held until offline auto tuning is performed again. However, the tuning data is cleared when performing All parameter clear.

- If offline auto tuning has ended in error, motor constants are not set.
Perform an inverter reset and perform tuning again.





Error display	Error cause	Countermeasures
8	Forced end	Set "11" in Pr.96 and retry.
9	Inverter protective function operation	Make the setting again.
91	The current limit (stall prevention) function is activated.	Set the acceleration/deceleration time longer. Set Pr.156 Stall prevention operation selection = "1".
92	The converter output voltage fell to 75% of the rated voltage.	Check for the power supply voltage fluctuation.
93	Calculation error. The motor is not connected.	Check the motor wiring and make the setting again.

- When tuning is ended forcibly by pressing the STOP/RESET key or turning OFF the start signal (STF or STR) during tuning, offline tuning does not end properly. (The motor constants have not been set.)
Perform an inverter reset and perform tuning again.
- When the rated power supply of the motor is 200/220 V (400/440 V) 60 Hz, set the rated motor current multiplied by 1.1 in **Pr.9 Electronic thermal O/L relay** after tuning is complete.
- For a motor with a PTC thermistor, thermal protector, or some other thermal detector, set "0" (motor overheat protection by inverter invalid) in **Pr.9** to protect the motor from overheating.

NOTE

- An instantaneous power failure occurring during tuning will result in a tuning error. After power is restored, the inverter starts normal operation. Therefore, when the STF (STR) signal is ON, the motor starts forward (reverse) rotation.
- Any fault occurring during tuning is handled as in the normal operation. However, if the retry function is set, no retry is performed.
- The set frequency monitor displayed during the offline auto tuning is 0 Hz.

« Parameters referred to »

- Pr.9 Electronic thermal O/L relay  [page 166](#)
- Pr.65, Pr.67 to Pr.69 Retry function  [page 179](#)
- Pr.71 Applied motor  [page 261](#)
- Pr.79 Operation mode selection  [page 142](#)
- Pr.156 Stall prevention operation selection  [page 195](#)

13.8 Power failure time deceleration-to-stop function



This is a function to decelerate the motor to a stop when an instantaneous power failure or undervoltage occurs.

Pr.	Name	Initial value	Setting range	Description
261 A730	Power failure stop selection	0	0	The inverter output is shut off at an undervoltage or when a power failure occurs.
			1	The inverter decelerates the motor to a stop at an undervoltage or when a power failure occurs.
			2	The inverter decelerates the motor to a stop at an undervoltage or when a power failure occurs. The inverter re-accelerates the motor if the power restores during the deceleration.

◆ Power failure stop function (Pr.261 = "1")

- Even if power is restored during deceleration triggered by a power failure, deceleration stop is continued after which the inverter stays stopped. To restart operation, turn the start signal OFF then ON again.

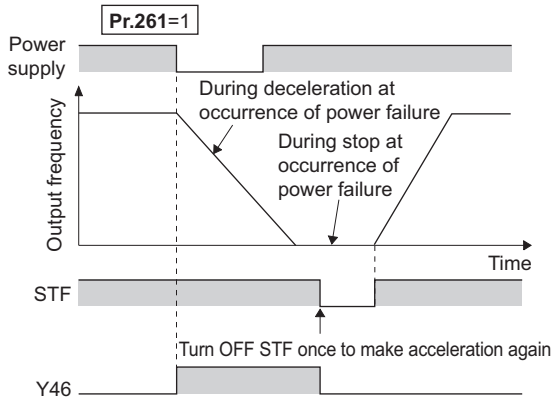

NOTE

- If the automatic restart after instantaneous power failure is selected (**Pr.57 Restart coasting time** ≠ "9999") while the power failure time deceleration stop function is set enabled (**Pr.261 = "1"**), the power failure time deceleration stop function is disabled.
- When the power failure time deceleration stop function is enabled (**Pr.261 = "1"**), the inverter does not start even if the power is turned ON or inverter reset is performed with the start signal (STF/STR) ON. Turn OFF the start signal once and then ON again to make a start.

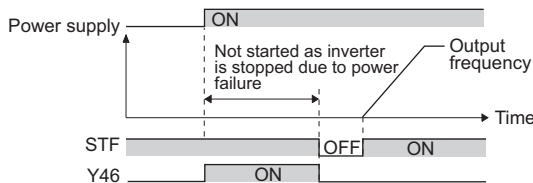

◆ Continuous operation function at instantaneous power failure (Pr.261 = "2")

- The motor re-accelerates to the set frequency when the power restores during the deceleration triggered by a power failure.

If the power is restored after stoppage by a power failure, a restart operation is performed when automatic restart after instantaneous power failure (Pr.57 ≠ "9999") is selected.

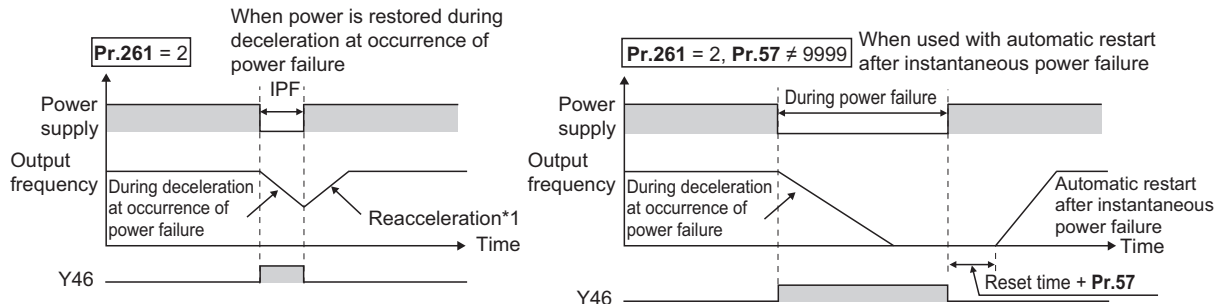

◆ During deceleration at occurrence of power failure (Y46) signal

- After deceleration by a power failure, the inverter is not restarted even though the start command is input. Check the During deceleration at occurrence of power failure (Y46) signal at a power failure. (For example, when input phase loss protection (E.ILF) occurs.)
- The Y46 signal is turned ON during deceleration at occurrence of power failure and in a stop status after deceleration at occurrence of power failure.
- For the Y46 signal, set "46" (positive logic) or "146" (negative logic) in any parameter from Pr.190 to Pr.196 (Output terminal function selection) to assign the function.

NOTE

- The power failure stop function is disabled in the following cases: during a stop, at an inverter reset, when the MRS signal is input, and when a fault occurs.
- Changing the terminal assignment using Pr.190 to Pr.196 (Output terminal function selection) may affect the other functions. Set parameters after confirming the function of each terminal.

⚠ CAUTION

- Even if the power failure time deceleration-to-stop function is set, some loads might cause an inverter fault and the motor might coast. The motor coasts if sufficient regenerative power is not obtained from the motor.

Parameters referred to

Pr.57 Restart coasting time [page 307](#), [page 312](#)

Pr.190 to Pr.196 (Output terminal function selection) [page 226](#)

13.9 Trace function

- The operating status of the inverter can be traced and temporarily stored in the RAM in the inverter. The data stored in the RAM is deleted when the power supply is turned OFF. (The data is retained at inverter reset.)
- Stored data can be monitored by FR Configurator2, and the status of the inverter can be analyzed.

Pr.	Name	Initial value	Setting range	Description				
1020 A900	Trace operation selection	0 ^{*1}	0	Without trace operation				
			1	Sampling start				
			2	Forced trigger				
			3	Sampling stop				
1022 A902	Sampling cycle	1	1, 2, 5, 10, 50, 100, 500, 1000	Set the sampling cycle. 1: 1 ms, 2: 2 ms, 5: 5 ms, 10: 10 ms, 50: 50 ms, 100: 100 ms, 500: 500 ms, 1000: 1 s				
1023 A903	Number of analog channels	4	1 to 8	Select the number of analog channels for sampling.				
1024 A904	Sampling auto start	0	0	Manual sampling start				
			1	Sampling starts automatically when the power supply is turned ON or at a reset				
1025 A905	Trigger mode selection	0	0	Fault trigger				
			1	Analog trigger				
			2	Digital trigger				
			3	Analog or digital trigger (OR logic)				
1026 A906	Number of sampling before trigger	90%	0% to 100%	Set the percentage of the pre-trigger sampling time with respect to the overall sampling time.				
					1027 A910	Analog source selection (1ch)	201	Select the analog data (monitor item) for sampling on each channel.
					1028 A911		202	
					1029 A912		203	
1030 A913	204							
1031 A914	205							
1032 A915	206							
1033 A916	207							
1034 A917	208							
1035 A918	Analog trigger channel	1	1 to 8	Select the analog channel to be the trigger.				
1036 A919	Analog trigger operation selection	0	0	Sampling starts when the value of the analog monitor exceeds the value set at the trigger level (Pr.1037)				
			1	Sampling starts when the value of the analog monitor falls below the value set at the trigger level (Pr.1037)				
1037 A920	Analog trigger level	1000	600 to 1400	Set the level at which the analog trigger turns ON. The trigger level is the value obtained by subtracting 1000 from the set value.				

Pr.	Name	Initial value	Setting range	Description
1038 A930	Digital source selection (1ch)	0	0 to 255	Select the digital data (I/O signal) for sampling on each channel.
1039 A931	Digital source selection (2ch)	0		
1040 A932	Digital source selection (3ch)	0		
1041 A933	Digital source selection (4ch)	0		
1042 A934	Digital source selection (5ch)	0		
1043 A935	Digital source selection (6ch)	0		
1044 A936	Digital source selection (7ch)	0		
1045 A937	Digital source selection (8ch)	0		
1046 A938	Digital trigger channel	1	1 to 8	Select the digital channel to be the trigger.
1047 A939	Digital trigger operation selection	0	0	Tracing starts when the signal turns ON
		1	1	Tracing starts when the signal turns OFF

*1 The read value is always "0".

◆ Operation outline

- This function is used to sample the status data (analog monitor and digital monitor) of the inverter, trace the sampling data when a trigger (trace start condition) occurs, and stores the resulting trace data.
- When the trace function is set enabled, samplings are collected and the inverter goes into the pre-trigger status.
- In the pre-trigger status, samples are collected, and the trigger standby status is entered when sufficient samples for the number of pre-trigger samples have been collected.
- When a trigger occurs in the trigger standby status, tracing is started and the trace data is stored.

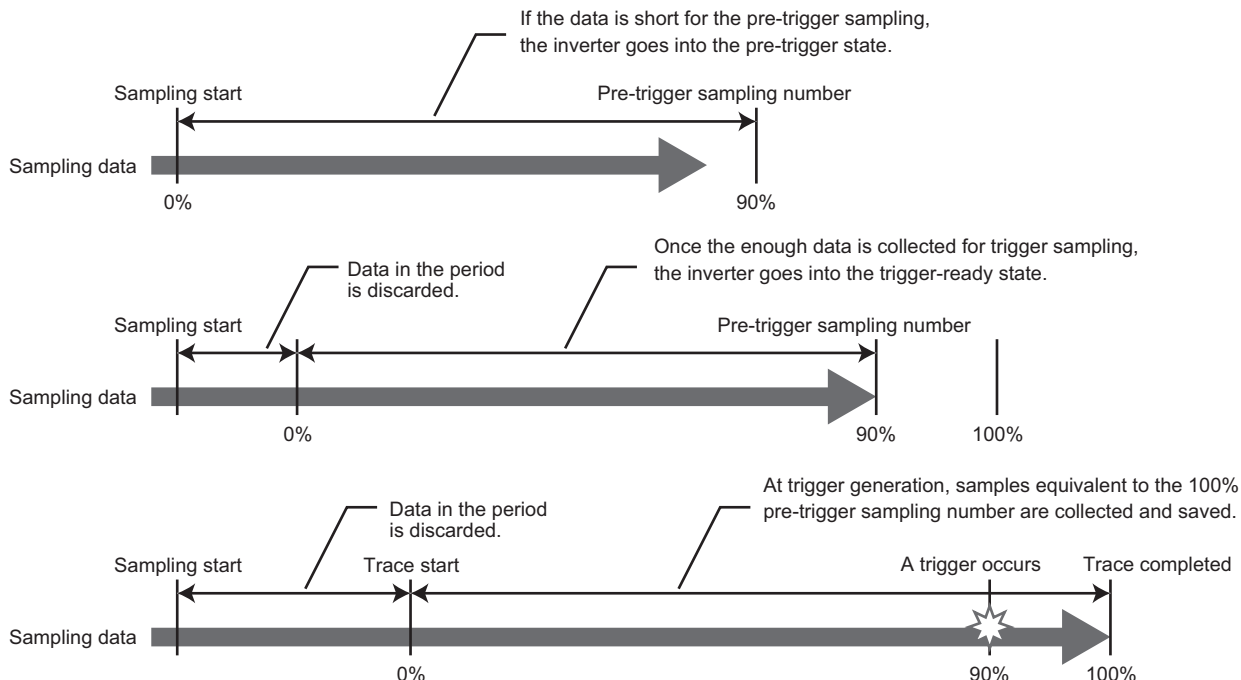

◆ Tracing procedure

- 1.** Prior setting for tracing
Set **Pr.1022 Sampling cycle** and **Pr.1023 Number of analog channels** according to the necessary sampling time.
Use **Pr.1027 to Pr.1034** to set analog sources, and **Pr.1038 to Pr.1045** to set digital sources.
Set a trigger type in **Pr.1025**.
- 2.** Tracing
Sampling starts according to the **Pr.1020 and Pr.1024** settings.
The trace status can be monitored. (Refer to [page 325](#).)
- 3.** Waveform check
By using FR Configurator2, trace data stored in the internal RAM can be displayed on a computer screen.
For details, refer to the Instruction Manual of FR Configurator2.

◆ Selection of sampling time (Pr.1022, Pr.1023)

- The sampling time is determined by the sampling cycle and the number of data acquisition points. The number of data acquisition points varies depending on the setting in **Pr.1023 Number of analog channels**.

Pr.1023 Number of analog channels	Memory mode sampling time		Number of data acquisition points
	Minimum (Pr.1022 = "1")	Maximum (Pr.1022 = "1000")	
1	1704 ms	1704 s	1704
2	1280 ms	1280 s	1280
3	1024 ms	1024 s	1024
4	852 ms	852 s	852
5	728 ms	728 s	728
6	640 ms	640 s	640
7	568 ms	568 s	568
8	512 ms	512 s	512

◆ Analog source (monitor item) selection

- Select the analog sources (monitor items) to be set to **Pr.1027 to Pr.1034** from the following table.

Setting value	Monitor item ^{*1}	Trigger level criterion ^{*2}
1	Output frequency/speed	*3
2	Output current	*3
3	Output voltage	*3
5	Frequency setting value/motor speed setting	*3
6	Running speed	*3
7	Motor torque	*3
8	Converter output voltage	*3
9	Regenerative brake duty	*3
10	Electronic thermal O/L relay load factor	*3
11	Output current peak value	*3
12	Converter output voltage peak value	*3
13	Input power	*3
14	Output power	*3
17	Load meter	*3
18	Motor excitation current	*3
20	Cumulative energization time	65535
23	Actual operation time	65535
24	Motor load factor	*3
32	Torque command	*3
33	Torque current command	*3
37	Heat sink temperature	*3
52	PID set point	*3
53	PID measured value	*3
54	PID deviation	*3
61	Motor thermal load factor	*3
62	Inverter thermal load factor	*3

Setting value	Monitor item ^{*1}	Trigger level criterion ^{*2}
64	PTC thermistor resistance	Pr.561
67	PID measured value 2	*3
68	Emergency drive status	65535
91	PID manipulated amount	*3
97	Dancer main set speed	*3
98	Control circuit temperature	*3
201	*Output frequency	Rated motor frequency
202	*U-phase output current	ND rated current
203	*V-phase output current	ND rated current
204	*W-phase output current	ND rated current
205	Converter output voltage	400/800 V
206	*Output current (all three phases)	ND rated current
207	*Excitation current (A)	ND rated current
208	*Torque current (A)	ND rated current
209	Terminal 2	100%
210	Terminal 4	100%
212	*Excitation current (%)	100%
213	*Torque current (%)	100%
230	*Output frequency (signed)	Rated motor frequency
231	*Motor speed (with sign)	*4
232	*Speed command (with sign)	*4
235	*Torque command	100%
236	*Motor torque	100%
237	*Excitation current command	100%
238	*Torque current command	100%

1 "" shows a monitor item with a high-speed sampling cycle.

*2 Indicates a criterion at 100% when the analog trigger is set.

*3 Refer to the full-scale value of terminal AM (on page 216).

*4 Rated motor frequency × 120 / number of motor poles

◆ Digital source (monitor item) selection

- Select the digital sources (input/output signals) to be set to **Pr.1038 to Pr.1045** from the following table. When a value other than the ones in the following table is set, "0" (OFF) is applied for indication.

Setting value	Signal name	Pr.	Remarks
0	—	—	Input status of an external input terminal For details on the signals, refer to page 252 .
1	STF	178	
2	STR	179	
5	RL	180	
6	RM	181	
7	RH	182	
101	RUN	190	
105	FU	191	
106	A,B,C	192	
152	Forward running	—	Output status of the signal (via communication) For details on the signals, refer to page 226 .
153	Reverse running	—	
154	NET SU	—	
155	NET OL	—	
156	NET Y1	193	
159	NET Y2	194	
160	NET Y3	195	
161	NET Y4	196	
166	NET ALM	—	

Setting value	Signal name	Pr.	Remarks
201	NET AU	—	Input status of the signal (via communication) For details on the signals, refer to page 252 .
202	NET STF	—	
203	NET STR	—	
204	NET RL	180	
205	NET RM	181	
206	NET RH	182	
207	NET RT	—	
208	NET MRS	—	
209	NET JOG2	—	
210	NET X1	185	
211	NET X2	186	
213	NET X3	187	
214	NET X4	188	
215	NET X5	189	

◆ Trigger setting (Pr.1025, Pr.1035 to Pr.1037, Pr.1046, Pr.1047)

- Set the trigger generating conditions and the trigger target channels.

Pr.1025 setting	Trigger generating conditions	Selection of trigger target channel
0	Tracing starts when inverter enters a fault status (protective function activated)	—
1	Tracing starts when analog monitor satisfies trigger conditions	Pr.1035
2	Tracing starts when digital monitor satisfies trigger conditions	Pr.1046
3	Tracing starts when either of analog or digital monitor satisfies trigger conditions (OR)	Pr.1035, Pr.1046
4	Tracing starts when both of analog or digital monitor satisfies trigger conditions (AND)	Pr.1035, Pr.1046

- Set the trigger generation conditions for the analog monitor.

Pr.1036 setting	Trigger generation conditions	Trigger level setting
0	Sampling starts when the analog data targeted for the trigger exceeds the value specified at the trigger level	Set the trigger level from 600 to 1400 (-400% to 400% ^{*1}) in Pr.1037 .
1	Sampling starts when the analog data targeted for the trigger falls below the value specified at the trigger level	

*1 In **Pr.1037**, set the number obtained by adding 1,000 to the trigger level.

- Set the trigger generation conditions for the digital monitor.

Pr.1047 setting	Trigger generation conditions
0	Tracing starts when the digital data targeted for the trigger turns ON
1	Tracing starts when the digital data targeted for the trigger turns OFF

◆ Start of sampling (Pr.1020, Pr.1024)

- Set the trace operation. The trace operation is set in **Pr.1020 Trace operation selection**.
- When "1" is set in **Pr.1020**, sampling starts.
- When "2" is set in **Pr.1020**, it is regarded that a trigger occurs (forced trigger), and the sampling stops and the tracing starts.
- When "3" is set in **Pr.1020**, sampling stops.
- To start sampling automatically when the power supply at power-ON or at a recovery after an inverter reset, set "1" in **Pr.1024 Sampling auto start**.

Pr.1020 setting	Operation	Setting condition
0	Sampling standby	—
1	Sampling start	Tracing stopped (sampling stopped)
2	Forced trigger (sampling stop)	During trace operation (during sampling)
3	Sampling stop	During trace operation (during sampling)

◆ Selection of trace operation by input terminal (TRG signal, TRC signal)

- Trace operation can be selected by signal inputs.
- A forced trigger can be applied when the Trace trigger input (TRG) signal is ON.
- Sampling is started and stopped by the Trace sampling start/end (TRC) signal turning ON and OFF, respectively.
- To input the TRG signal, set "46" in any parameter from **Pr.178 to Pr.182 and Pr.185 to Pr.189 (Input terminal function selection)**, and to input the TRC signal, set "47" to assign the function.

NOTE

- Changing the terminal assignment using **Pr.178 to Pr.182 and Pr.185 to Pr.189 (Input terminal function selection)** may affect the other functions. Set parameters after confirming the function of each terminal.

◆ Sampling retry

- If any error is found in the trace data, the sampling stops and then restarts (sampling retry).
- If another error is found within a minute from when an error is found, the sampling stops (sampling retry count excess).
- The sampling retry status can be checked by monitoring the trace status.

◆ Monitoring the trace status

- The trace status can be monitored on the operation panel by setting "38" in **Pr.52 Operation panel main monitor selection, Pr.774 to Pr.776 (Operation panel monitor selection), or Pr.992 Operation panel setting dial push monitor selection**.

The content depends on the digits on the operation panel.

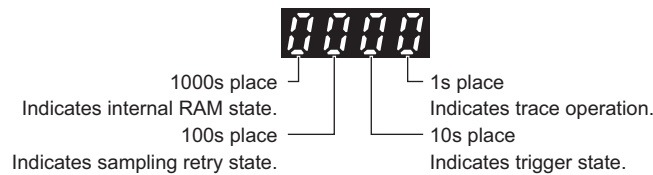

Monitor value	Trace status			
	Fourth digit	Third digit	Second digit	First digit
0 or no display ^{*1}	No trace data in internal RAM	Sampling retry not performed	Trigger not detected	Tracing stopped
1	Trace data in internal RAM	Sampling retry performed	Trigger detected	Trace operation
2	—	Sampling retry count excess	—	—

^{*1} The value(s) "0" to the left of the leftmost non-zero value is(are) not shown in the monitor display. For example, if no trace data is in internal RAM, sampling retry is not performed, no trigger is detected, and trace operation is performed, "1" appears (not "0001").

- During trace operation, the Trace status (Y40) signal can be output.
To use the Y40 signal, set "40" (positive logic) or "140" (negative logic) in any parameter from **Pr.190 to Pr.196 (Output terminal function selection)** to assign the function to an output terminal.

 **NOTE**

- Changing the terminal assignment using **Pr.190 to Pr.196 (Output terminal function selection)** may affect the other functions. Set parameters after confirming the function of each terminal.

«**Parameters referred to**»

Pr.52 Operation panel main monitor selection  [page 208](#)

Pr.178 to Pr.182 and Pr.185 to Pr.189 (Input terminal function selection)  [page 243](#)

Pr.190 to Pr.196 (Output terminal function selection)  [page 226](#)

14 (G) Control Parameters

Purpose	Parameter to set			Refer to page
To set the starting torque manually	Manual torque boost	P.G000, P.G010	Pr.0, Pr.46	327
To set the motor constant	Base frequency, base frequency voltage	P.G001, P.G002, P.G011	Pr.3, Pr.19, Pr.47	329
To select the V/F pattern matching the application	Load pattern selection	P.G003	Pr.14	331
To perform energy saving operation	Energy saving operation	P.G030	Pr.60	333
To compensate the motor slip amount when replacing an SF-JR motor with an SF-PR motor	SF-PR slip amount adjustment mode	P.G060, P.G061	Pr.673, Pr.674	334
To adjust the motor braking torque	DC injection brake	P.G100, P.G101, P.G110, P.G111	Pr.10 to Pr.12, Pr.795	335
To coast the motor to a stop	Selection of motor stop method	P.G106	Pr.250	338
To use the regeneration unit to increase the motor braking torque	Regenerative brake selection	P.E300, P.G107, P.T720	Pr.17, Pr.30, Pr.70	340
To avoid overvoltage fault due to regenerative driving by automatic adjustment of output frequency	Regeneration avoidance function	P.G120, P.G121, P.G123 to P.G125	Pr.882, Pr.883, Pr.885, Pr.886, Pr.665	345
To decrease the deceleration time of the motor	Increased magnetic excitation deceleration	P.G130 to P.G132	Pr.660 to Pr.662	348
To select the control method	Control method selection	P.G200	Pr.800	72
To secure the low-speed torque by compensating the slip of the motor	Slip compensation	P.G203 to P.G205	Pr.245 to Pr.247	350
To adjust the speed control gain	Speed control gain	P.G211 to P.G214, P.C114	Pr.820, Pr.821, Pr.824, Pr.825	90
To suppress the machine resonance	Speed smoothing control	P.G410, P.G411	Pr.653, Pr.654	351
To adjust the speed gain for Advanced magnetic flux vector control	Speed control gain	P.G932	Pr.89	75
To suppress vibration	Vibration suppression control	P.G225 to P.G228, P.C107, P.C108	Pr.532 to Pr.535, Pr.707, Pr.724	352

14.1 Manual torque boost



Voltage drop in the low-frequency range can be compensated, improving reduction of the motor torque in the low-speed range.

- Motor torque in the low-frequency range can be adjusted according to the load, increasing the motor torque at the start up.
- By using the RT signal, it is possible to switch between 2 types of torque boost.

Pr.	Name	Initial value	Setting range	Description
0 G000	Torque boost	2%, 3%, 4%, 6%*1	0% to 30%	Set the output voltage at 0 Hz in %.
46 G010	Second torque boost	9999	0% to 30%	Set the torque boost value at when the RT signal is ON.
			9999	Without the second torque boost

*1 The initial value differs depending on the inverter capacity as follows. For the SLD rating (Pr.570 = "0"), the initial value is changed. (Refer to page 108.)

Inverter	Initial value
FR-D820-0.75K-042 or lower FR-D840-0.75K-022 or lower FR-D820S-0.75K-042 or lower FR-D810W-0.75K-042 or lower	6%
FR-D820-1.5K-070 to FR-D820-3.7K-165 FR-D840-1.5K-037 to FR-D840-3.7K-081 FR-D820S-1.5K-070 or higher	4%
FR-D820-5.5K-238, FR-D820-7.5K-318 FR-D840-5.5K-120, FR-D840-7.5K-163	3%

Inverter	Initial value
FR-D820-11K-450 or higher FR-D840-11K-230 or higher	2%

◆ Starting torque adjustment

- Assuming **Pr.19 Base frequency voltage** is 100%, set the output voltage at 0 Hz to **Pr.0 (Pr.46)** in percentage.
- Perform the adjustment of the parameter little by little (approximately 0.5%), and confirm the status of the motor each time. The motor may overheat when the value is set too high. Do not use more than 10% as a guideline.

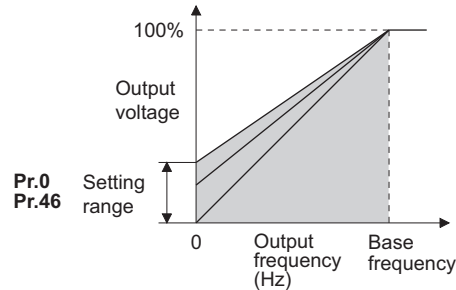

◆ Setting two types of torque boosts (RT signal, Pr.46)

- When changing the torque boost depending on the application or when using single inverter switching between multiple motors, use **Pr.46 Second torque boost**.
- Pr.46** is enabled when the RT signal is ON. To input the RT signal, set "3" in any parameter from **Pr.178 to Pr.182** and **Pr.185 to Pr.189 (Input terminal function selection)** to assign the function.

NOTE

- The RT signal is the Second function selection signal. The RT signal also enables other second functions. (Refer to [page 257](#).)
- Set a larger value when the distance between the inverter and the motor is long or when there is not enough motor torque in the low-speed range. It may cause overcurrent trip when it is set too large.
- Setting for **Pr.0 and Pr.46** becomes enabled only when the V/F control is selected.
- When the initial value is set in **Pr.0**, the **Pr.0** setting is automatically changed by changing the **Pr.71 Applied motor or Pr.81 Number of motor poles** setting. (Refer to [page 261](#).)
- Changing the terminal assignment using **Pr.178 to Pr.182** and **Pr.185 to Pr.189 (Input terminal function selection)** may affect the other functions. Set parameters after confirming the function of each terminal.

Parameters referred to

Pr.3 Base frequency, Pr.19 Base frequency voltage [page 329](#)

Pr.71 Applied motor [page 261](#)

Pr.178 to Pr.182 and Pr.185 to Pr.189 (Input terminal function selection) [page 252](#)

14.2 Base frequency voltage



Use this function to adjust the inverter outputs (voltage, frequency) to match with the motor rating.

Pr.	Name	Initial value ^{*1}		Setting range	Description
		Gr.1	Gr.2		
3 G001	Base frequency	60 Hz	50 Hz	0 to 590 Hz	Set the frequency at the rated motor torque. (50/60 Hz)
19 G002	Base frequency voltage	9999	8888	0 to 1000 V	Set the base voltage.
				8888	95% of the power supply voltage (For a single-phase 100 V power input model, 95% of twice of the power supply voltage)
				9999	Same as the power supply voltage (For a single-phase 100 V power input model, twice of the power supply voltage)
47 G011	Second V/F (base frequency)	9999		0 to 590 Hz	Set the base frequency when the RT signal is ON.
				9999	Second V/F disabled

*1 Gr.1 and Gr.2 are the parameter initial value groups. (Refer to page 46.)

◆ Base frequency setting (Pr.3)

- When operating a standard motor, generally set the rated frequency of the motor in **Pr.3 Base frequency**. When the motor operation require switching to the commercial power supply, set the power supply frequency in **Pr.3**.
- When the frequency described on the motor rating plate is "50 Hz" only, make sure to set to 50 Hz. When it is set to 60 Hz, the voltage will drop too much, causing insufficient torque. As a result, the inverter protective function may be activated due to overload.
A caution is required especially in case of **Pr.14 Load pattern selection** = "1" (variable torque load).
- When using the Mitsubishi Electric constant torque motor, set **Pr.3** to 60 Hz.

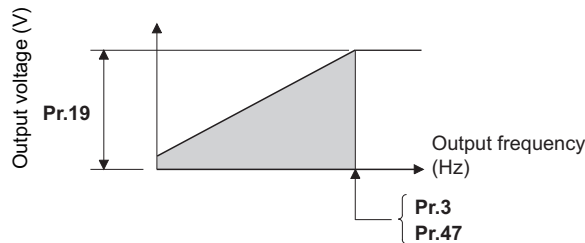

◆ Setting two types of base frequencies (Pr.47)

- To change the base frequency when using a single inverter switching between multiple motors, use **Pr.47 Second V/F (base frequency)**.
- **Pr.47** is enabled when the RT signal is ON. To input the RT signal, set "3" in any parameter from **Pr.178 to Pr.182** and **Pr.185 to Pr.189 (Input terminal function selection)** to assign the function.

NOTE

- The RT signal is the Second function selection signal. The RT signal also enables other second functions. (Refer to page 257.)

◆ Setting of base frequency voltage (Pr.19)

- Use **Pr.19 Base frequency voltage** to set the base voltage (for example, rated motor voltage).
- When it is set lower than the power supply voltage (approximately twice of the power supply voltage for a single-phase 100 V power input model), maximum output voltage of the inverter will be the voltage set in **Pr.19**.
- **Pr.19** can be used in the following cases.
 - (a) When regenerative driving (continuous regeneration, etc.) is performed frequently
Output voltage will get higher than the specification during the regenerative driving, which may cause overcurrent trip (E.OC[]) by the increase in motor current.
 - (b) When the fluctuation of power supply voltage is high
When the power supply voltage exceeds the rated voltage of the motor, fluctuation of rotation speed or overheating of motor may occur due to excessive torque or increase in motor current.

NOTE

- When the Advanced magnetic flux vector control or PM sensorless vector control is selected, **Pr.3**, **Pr.47**, and **Pr.19** will become disabled, and **Pr.83** and **Pr.84** will become enabled.
However, S-pattern curve with **Pr.29 Acceleration/deceleration pattern selection** = "1" (S-pattern acceleration/deceleration A) enables **Pr.3** or **Pr.47**. (S-pattern curve under PM sensorless vector control is the rated frequency of the motor.)
- Changing the terminal assignment using **Pr.178 to Pr.182** and **Pr.185 to Pr.189 (Input terminal function selection)** may affect the other functions. Set parameters after confirming the function of each terminal.

Parameters referred to

Pr.14 Load pattern selection  [page 331](#)

Pr.29 Acceleration/deceleration pattern selection  [page 133](#)

Pr.83 Rated motor voltage, Pr.84 Rated motor frequency  [page 331](#)

Pr.178 to Pr.182 and Pr.185 to Pr.189 (Input terminal function selection)  [page 252](#)

14.3 Load pattern selection



Optimal output characteristics (V/F characteristics) for application or load characteristics can be selected.

Pr.	Name	Initial value	Setting range	Description
14 G003	Load pattern selection	0	0	For constant-torque load
			1	For variable-torque load
			2	For constant-torque lift (boost at reverse rotation: 0%)
			3	For constant-torque lift (boost at forward rotation: 0%)

◆ Application for constant-torque load (Pr.14 = "0", initial value)

- The output voltage will change linearly against the output frequency at the base frequency or lower.
- Set this parameter when driving a load that has constant load torque even when the rotation speed is changed, such as conveyor, dolly, or roll drive.

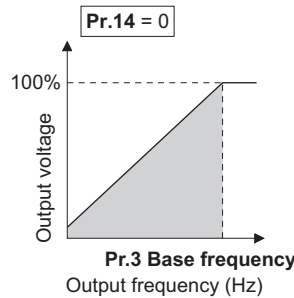

Point

Select for constant-torque load (setting value "0") even for fan and pump in the following cases.

- When accelerating a blower with large moment of inertia (J) in a short period of time.
- When it is a constant-torque load such as rotary pump or gear pump.
- When the load torque increases in low speed such as screw pump.

◆ Application for variable-torque load (Pr.14 = "1")

- The output voltage will change in square curve against the output frequency at the base frequency or lower.
- Set this parameter when driving a load with load torque change proportionally against the square of the rotation speed, such as a fan or pump.

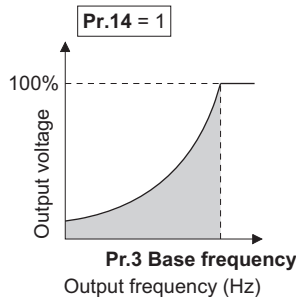

◆ Vertical lift load applications (Pr.14 = "2, 3")

- Set "2" when a vertical lift load is fixed as power driving load at forward rotation and regenerative load at reverse rotation.
- **Pr.0 Torque boost** is valid during forward rotation, and torque boost is automatically changed to "0%" during reverse rotation.
- Set "3" for an elevated load that is in the driving mode during reverse rotation and in the regenerative load mode during forward rotation according to the load weight, e.g. counterweight system.
- **Pr.46 Second torque boost** is enabled when the RT signal is ON. To input the RT signal, set "3" in any parameter from **Pr.178 to Pr.182 and Pr.185 to Pr.189 (Input terminal function selection)** to assign the function.

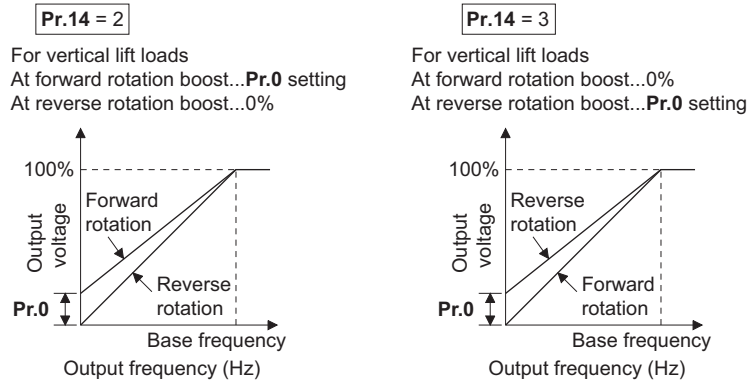

NOTE

- When torque is continuously regenerated as vertical lift load, it is effective to set the rated voltage in **Pr.19 Base frequency voltage** to prevent faults due to current at regeneration.

Parameters referred to

Pr.0 Torque boost [page 327](#)

Pr.178 to Pr.182 and Pr.185 to Pr.189 (Input terminal function selection) [page 252](#)

14.4 Energy saving control



The inverter will automatically perform energy saving operation without setting detailed parameters. This control method is suitable for applications such as fans and pumps.

Pr.	Name	Initial value	Setting range	Description
60 G030	Energy saving control selection	0	0	Normal operation
			9	Optimum excitation control

◆ Optimum excitation control (Pr.60 = "9")

- Setting **Pr.60** = "9" will select the Optimum excitation control.
- The Optimum excitation control is a control method to decide the output voltage by controlling the excitation current so the efficiency of the motor is maximized.
- Optimum excitation control will be enabled under V/F control and Advanced magnetic flux vector control.

NOTE

- In the Optimum excitation control mode, an energy saving effect is not expected when the motor capacity is extremely small compared with the inverter capacity or when multiple motors are connected to a single inverter.
- When the Optimum excitation control mode is selected, the deceleration time may become longer than the setting value. Also, it may cause overvoltage more often compared to constant-torque load characteristics, so set the deceleration time longer.
- When the motor becomes unstable during the acceleration, set the acceleration time longer.
- Output current may increase slightly with the energy saving operation mode or the Optimum excitation control mode since the output voltage is controlled.

14.5 SF-PR slip amount adjustment mode



- As compared to our conventional SF-JR motor, the slip amount is small for the high-performance energy-saving SF-PR motor. When replacing the SF-JR to the SF-PR, the slip amount is reduced and the rotations per minute increases. Therefore, when the SF-PR is used with the same frequency setting as that of the SF-JR, power consumption may increase as compared to the SF-JR.
- By setting the slip amount adjustment mode, the frequency command can be adjusted to keep the rotations per minute of the SF-PR equivalent to those of the SF-JR for power consumption reduction.

Pr.	Name	Initial value	Setting range	Description
673 G060	SF-PR slip amount adjustment operation selection	9999	2, 4, 6	Set the number of SF-PR motor poles.
			9999	The slip amount adjustment is disabled.
674 G061	SF-PR slip amount adjustment gain	100%	0% to 500%	Setting is available for fine adjustment of the slip amount.

- By setting the number of SF-PR motor poles in **Pr.673 SF-PR slip amount adjustment operation selection**, the SF-PR slip amount adjustment mode is activated.
- The SF-PR slip amount adjustment mode is available only under V/F control.
- Use **Pr.674 SF-PR slip amount adjustment gain** to fine-tune the rotations per minute. To reduce the rotations per minute (to increase the compensation frequency), set a larger value in **Pr.674**. To increase the rotations per minute (to reduce the compensation frequency), set a smaller value in **Pr.674**. (Lower rotations per minute reduce the power consumption, and higher rotations per minute increase the power consumption.)

NOTE

- The slip amount adjustment is not available in the following conditions.
During acceleration/deceleration, during DC injection brake operation, during PID control, during stall prevention operation, during regeneration avoidance operation, during traverse operation, and while the slip compensation is valid (**Pr.245**).
- The slip amount adjustment is not available when the applicable motor capacity of the inverter is not compatible with the SF-PR. (For the details of the applicable motor capacity, refer to the Instruction Manual (Connection).)

14.6 DC injection brake

- Adjust the braking torque and timing to stop the motor using the DC injection brake.
When the DC injection brake operation is used, DC voltage is applied to the motor to prevent rotation of the motor shaft.
When a motor shaft is rotated by external force, the motor shaft does not go back to the original position.

Pr.	Name	Initial value	Setting range	Description
10 G100	DC injection brake operation frequency	3 Hz	0 to 120 Hz	Set the operation frequency for the DC injection brake.
11 G101	DC injection brake operation time	0.5 s	0	DC injection brake operation is not applied.
			0.1 to 10 s	Set the operation time for the DC injection brake.
12 G110	DC injection brake operation voltage	6%/4%/2% ^{*1*2*3}	0% to 30%	Set the DC injection brake voltage (torque). When set to "0", the DC injection brake is not applied.
795 G111	DC injection brake operation current level	9999	0% to 200%	Set the excitation current command during DC injection brake operation as the percentage against the rated motor current.
			9999	70%

*1 The initial value differs depending on the inverter capacity as follows.

Inverter	Initial value
FR-D820-0.2K-014 or lower FR-D820S-0.2K-014 or lower FR-D810W-0.2K-014 or lower	6%
FR-D820-0.4K-025 to FR-D820-7.5K-318 FR-D840-0.4K-012 to FR-D840-7.5K-163 FR-D820S-0.4K-025 or higher FR-D810W-0.4K-025 or higher	4%
FR-D820-11K-450 or higher FR-D840-11K-230 or higher	2%

*2 The initial value may be changed depending on the **Pr.570 Multiple rating setting** setting. (Refer to [page 108](#).)

*3 The setting value may be automatically changed according to the motor, depending on the **Pr.71 Applied motor** setting. (Refer to [page 264](#).)

◆ Setting of operating frequency (Pr.10)

- During deceleration, DC injection brake operates when the frequency reaches the setting of **Pr.10 DC injection brake operation frequency**.
- The frequency values to start brake operation are as follows.

Motor	Stopping method	Parameter setting	Frequency to start brake operation	
Induction motor	Press the STOP/RESET key on the operation panel. Turn OFF the STF/STR signal.	Pr.11 ≠ "0"	0.5 Hz or higher in Pr.10	Pr.10 setting
			Lower than 0.5 Hz in Pr.10 , and 0.5 Hz or higher in Pr.13	0.5 Hz
			Lower than 0.5 Hz in both Pr.10 and Pr.13	Pr.10 or Pr.13 setting, whichever larger
		Pr.11 = "0"	0.5 Hz or higher in Pr.10	Output shutoff at the Pr.10 setting value or lower
			Lower than 0.5 Hz in Pr.10 , and 0.5 Hz or higher in Pr.13	Output shutoff at 0.5 Hz or lower
	Lower than 0.5 Hz in both Pr.10 and Pr.13	Output shutoff at the Pr.10 or Pr.13 setting value (whichever larger) or lower		
	Set frequency to 0 Hz	—	Pr.13 setting or 0.5 Hz, whichever smaller	
PM motor	Press the STOP/RESET key on the operation panel. Turn OFF the STF/STR signal.	Pr.11 ≠ "0"	0 Hz	
		Pr.11 = "0"	Output shutoff at the Pr.10 setting value or lower	
	Set frequency to 0 Hz	—	0 Hz	

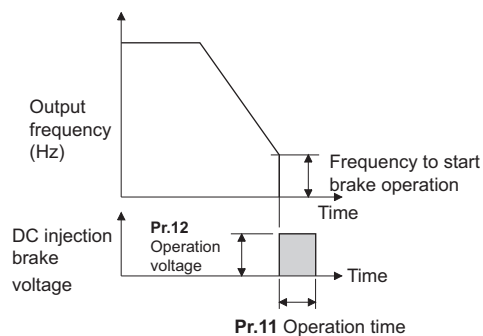

◆ Operation time setting (Pr.11)

- Set the operation time for DC injection brake in **Pr.11 DC injection brake operation time**.
- When the motor does not stop due to large load moment (J), increase the setting to ensure the effect.
- When **Pr.11** = 0 s, DC injection brake will not operate. (The motor starts to coast when the output frequency drops to the **Pr.10** setting or lower at a stop.)

◆ Setting of operation voltage (torque) (Pr.12)

- Set the percentage against the power supply voltage in **Pr.12 DC injection brake operation voltage**.
- When **Pr.12** = 0%, DC injection brake will not operate. (The motor starts to coast when the output frequency drops to the **Pr.10** setting or lower at a stop.)
- The **Pr.12** setting is disabled under PM sensorless vector control.

NOTE

- When the setting of **Pr.12** is the initial value, the setting corresponding to the motor is set according to the **Pr.71 Applied motor** setting. (Refer to [page 264](#).) However, when an energy saving motor (SF-HR or SF-HRCA) is used, change the **Pr.12** setting as shown below.

Motor capacity	Pr.12 setting
3.7 kW or lower	4%
5.5 kW, 7.5 kW	3%
11 kW or higher	2%

- Even if the setting value of **Pr.12** is made larger, braking torque will be limited so the output current will be within the rated current of the inverter.

◆ Brake operation list

- The DC injection brake operation under each control method is as follows.

Control method	Deceleration stop	LX-ON
V/F control	DC injection brake	—
Advanced magnetic flux vector control	DC injection brake	—
PM sensorless vector control	DC injection brake	DC injection brake

◆ Pre-excitation (LX) signal

- When the Pre-excitation (LX) signal is turned ON under PM sensorless vector control, pre-excitation (DC injection brake) starts during a stop.
- To input the LX signal, set "23" in any parameter from **Pr.178 to Pr.182** and **Pr.185 to Pr.189 (Input terminal function selection)** to assign the function.

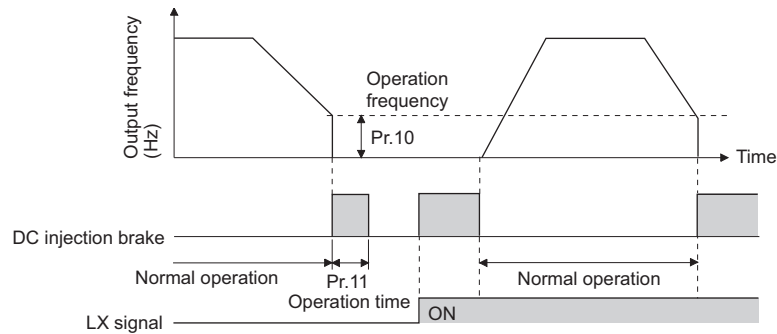

NOTE

- Changing the terminal assignment using **Pr.178 to Pr.182** and **Pr.185 to Pr.189 (Input terminal function selection)** may affect the other functions. Set parameters after confirming the function of each terminal.
- Note that during the pre-excitation operation, a voltage is applied to the motor even when the [RUN] LED on the operation panel or the FWD/REV indicator on the parameter unit is OFF.
- When offline auto tuning (**Pr.96 Auto tuning setting/status** ≠ "0") is performed during pre-excitation operation, pre-excitation is disabled.
- When the LX signal is ON and the start signal is OFF at the automatic restart after instantaneous power failure, the motor does not decelerate to stop from the detected motor speed, and pre-excitation is applied.
- If the pre-excitation is performed by turning ON the LX signal during coasting, the protective function (E.OC3) may be activated.

CAUTION

- Install a mechanical brake to make an emergency stop or to stay stopped for a long time.
- Wait until the machine stops completely, and fix the motor with a mechanical brake, then turn OFF the LX signal.

Parameters referred to

Pr.13 Starting frequency [page 139](#), [page 141](#)

Pr.71 Applied motor [page 261](#)

Pr.80 Motor capacity [page 266](#)

Pr.178 to Pr.182 and Pr.185 to Pr.189 (Input terminal function selection) [page 252](#)

14.7 Stop selection

Select the stopping method (deceleration stop or coasting) at turn-OFF of the start signal.

Coasting can be selected for the cases such that the motor is stopped with a mechanical brake at turn-OFF of the start signal.

The operation of the start signal (STF/STR) can be selected. (For the start signal operation selection, refer to [page 258](#).)

Pr.	Name	Initial value	Setting range	Description	
				Start signal (STF/STR) ^{*1}	Stop operation
250 G106	Stop selection	9999	0 to 100 s	STF signal: Forward rotation start STR signal: Reverse rotation start	The motor coasts to a stop after a lapse of the setting time when the start signal is turned OFF.
			1000 to 1100 s ^{*2}	STF signal: Start signal STR signal: Forward/reverse rotation signal	The motor coasts to a stop after a lapse of the (Pr.250 - 1000) seconds when the start signal is turned OFF.
			9999	STF signal: Forward rotation start STR signal: Reverse rotation start	The motor is decelerated to a stop when the start signal is turned OFF.
			8888 ^{*2}	STF signal: Start signal STR signal: Forward/reverse rotation signal	

*1 For the start signal operation selection, refer to [page 258](#).

*2 The start signal operation selection is available in External operation mode or when the start command source is External in the Network operation mode.

◆ To decelerate the motor to a stop

- Set **Pr.250** = "9999 (initial value) or 8888".
- The motor is decelerated to a stop when the start signal (STF/STR) is turned OFF.

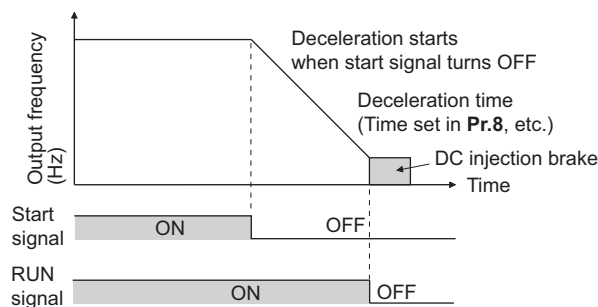

◆ To coast the motor to a stop

- Set the time required to shut off the output after the start signal is turned OFF in **Pr.250**. When "1000 to 1100" is set, output is shut off after a lapse of the (Pr.250 - 1000) seconds.
- The output is shut off after a lapse of the setting time of **Pr.250** when the start signal is turned OFF. Motor coasts to a stop.
- The RUN signal is turned OFF when the output is shut off.

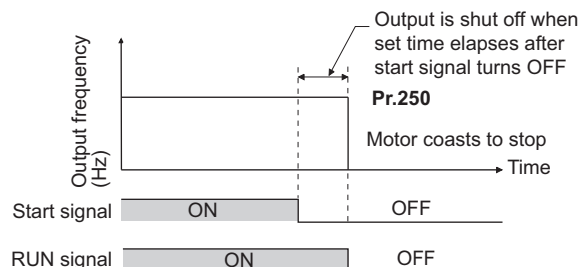

NOTE

- The stop selection setting is disabled when the following functions are operating.
Power failure stop function (**Pr.261**)
PU stop (**Pr.75**)
Deceleration stop due to a communication error (**Pr.502**)
JOG operation
Offline auto tuning
- When **Pr.250** ≠ "9999 or 8888", acceleration/deceleration is performed in accordance with the frequency command until the output is shut off by turning OFF the start signal.
- When the restart signal is turned ON during the motor coasting, the operation is resumed from **Pr.13 Starting frequency**.

Parameters referred to

Pr.7 Acceleration time, Pr.8 Deceleration time  [page 130](#)

Pr.12 DC injection brake operation voltage  [page 335](#)

Pr.13 Starting frequency  [page 139](#), [page 141](#)

Pr.75 Reset selection/disconnected PU detection/PU stop selection  [page 97](#)

Pr.261 Power failure stop selection  [page 318](#)

Pr.502 Stop mode selection at communication error  Instruction Manual (Communication)

14.8 Regenerative brake selection

- When performing frequent start and stop operation, usage rate of the regenerative brake can be increased by using the optional high-duty brake resistor (FR-ABR) or the brake unit (FR-BU2, BU, or FR-BU).
- The multifunction regeneration converter (FR-XC in power regeneration mode) is used for the continuous operation in the regenerative status. The multifunction regeneration converter (FR-XC in common bus regeneration mode) and high power factor converter (FR-HC2) can also be used to reduce harmonics, improve power factor, and operate continuously during regenerative driving.

Pr.	Name	Initial value	Setting range	Description	
30 E300	Regenerative function selection	0	0	No regenerative function Brake resistor (MRS, MYS type) Brake unit (FR-BU2) Multifunction regeneration converter (FR-XC) High power factor converter (FR-HC2)	
			1	Brake resistor (MYS type) used at 100% torque, 6%ED High-duty brake resistor (FR-ABR)	
			2	When the automatic restart operation after instantaneous power failure function is enabled while a brake resistor and a regeneration unit is used	
70 G107	Special regenerative brake duty	0%	0% to 100%	Set the %ED of the built-in brake transistor operation.	
17 T720	MRS/X10 terminal input selection	0	0	X10: Normally open input	MRS: Normally open input
			1	X10: Normally closed input (NC contact input specification)	
			2	X10: Normally open input	MRS: Normally closed input (NC contact input specification)
			3	X10: Normally closed input (NC contact input specification)	
			4	X10: Normally open input	External terminal: Normally closed input (NC contact input specification)
5	X10: Normally closed input (NC contact input specification)	Communication: Normally open input			

◆ When using the brake resistor (MRS, MYS type), brake unit (FR-BU2), multifunction regeneration converter (FR-XC), and high power factor converter (FR-HC2)

- Set Pr.30 = "0 (initial setting)". The Pr.70 setting is invalid. At this time, the regenerative brake duty is as follows.

Inverter	Regenerative brake duty
FR-D820-0.2K-014 or lower FR-D820S-0.2K-014 or lower FR-D810W-0.2K-014 or lower	0%
FR-D820-0.4K-025 to FR-D820-3.7K-165 FR-D820S-0.4K-025 or higher FR-D810W-0.4K-025 or higher	3%
FR-D820-5.5K-238 or higher FR-D840-0.4K-012 or higher	2%

- When connecting the converter unit (FR-XC or FR-HC2), assign the Inverter run enable (X10) signal to a contact input terminal. To ensure coordinated protection of the converter unit, use the Inverter run enable (X10) signal to shut off the inverter output. Input the Inverter operation enable (RYB/RDY/RDYB) signal of the converter unit. The X10 signal can be input only via an external input terminal. For the terminal used for the X10 signal input, set "10" (X10) in any parameter from Pr.178 to Pr.182 to assign the function.

◆ When using the brake resistor (MYS type) at 100% torque, 6%ED (FR-D820-3.7K-165 only)

- Set Pr.30 = "1".
- Set Pr.70 = 6%.

◆ **When using the high-duty brake resistor (FR-ABR) (FR-D820-0.4K-025 or higher, FR-D840-0.4K-012 or higher, FR-D820S-0.4K-025 or higher, and FR-D810W-0.4K-025 or higher)**

- Set **Pr.30** = "1".
- Set **Pr.70** as follows.

Inverter	Pr.70 setting
FR-D820-7.5K-318 or lower FR-D840-7.5K-163 or lower FR-D820S-2.2K-100 or lower FR-D810W-0.75K-042 or lower	10%
FR-D820-11K-450 or higher FR-D840-11K-230 or higher	6%

◆ **When the automatic restart after instantaneous power failure function is enabled**

- Set **Pr.30** = "2" to enable the automatic restart after instantaneous power failure function when using the high-duty brake resistor (FR-ABR), brake resistor (MRS, MYS type), brake unit (FR-BU2), multifunction regeneration converter (FR-XC), and high power factor converter (FR-HC2).
- Set **Pr.70** as follows.

Option used	Pr.70 setting	Remarks
FR-ABR	10%	FR-D820-7.5K-318 or lower FR-D840-7.5K-163 or lower FR-D820S-2.2K-100 or lower FR-D810W-0.75K-042 or lower
	6%	FR-D820-11K-450 or higher FR-D840-11K-230 or higher
MRS type, MYS type	3%	FR-D820-0.4K-025 or higher FR-D840-0.4K-012 or higher FR-D820S-0.4K-025 or higher FR-D810W-0.4K-025 or higher
MYS type (used at 100% torque / 6%ED)	6%	FR-D820-3.7K-165
FR-XC, FR-HC2, FR-BU2	0%	—

- When using the FR-XC or FR-HC2, enable the automatic restart after instantaneous power failure function in both the FR-XC/FR-HC2 and the inverter (**Pr.57 Restart coasting time** ≠ "9999").
- If the FR-XC or FR-HC2 detects the power failure during inverter running, the motor starts to coast since the Inverter operation enable (RYB or RDY) signal turns ON. After the power is restored and the Inverter operation enable (RYB or RDY) signal turns OFF, the inverter detects the motor speed (**Pr.162 Automatic restart after instantaneous power failure selection**) and restarts operation.

◆ Logic reversing of the Inverter run enable signal (X10 signal, Pr.17)

- Use **Pr.17 MRS/X10 terminal input selection** to select the X10 signal input specification between normally open (NO contact) and normally closed (NC contact). With the normally closed (NC contact) input specification, the inverter output is shut off by turning OFF (opening) the X10 signal.
- Change the **Pr.17** setting to change the inverter logic (NO/NC contact) according to the logic of the inverter operation enable signal sent from the converter unit.
- The logic of the MRS signal can also be selected by setting **Pr.17**. Refer to [page 255](#) to select the logic of the MRS signal.
- The response time of the X10 signal is within 2 ms.

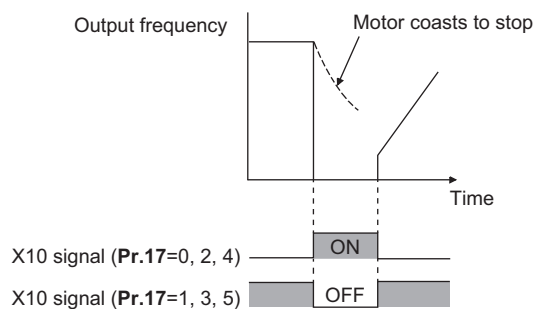

- Relationship between **Pr.17** and the Inverter run enable signal of each option unit

Pr.17 setting	Corresponding signals of the option unit		Operation according to the X10 signal status
	FR-HC2	FR-XC	
0, 2, 4 (initial value)	RDY (negative logic) (initial setting)	RYB	X10-ON: Inverter output shutoff (NO contact)
1, 3, 5	RDY (positive logic)	RYA	X10-OFF: Inverter output shutoff (NC contact)

NOTE

- When **Pr.30** = "0 or 2" and the X10 signal is not assigned to an input terminal, the MRS signal can be used as the X10 signal. The logic of the signal depends on that of the MRS signal (normally open input when **Pr.17** = "0 or 1", and normally closed input when **Pr.17** = "2 to 5").
- The MRS signal is valid regardless of whether it is input through the external terminal or via network, but when the MRS signal is used as the Inverter run enable (X10) signal, input the signal through the external terminal.
- If the output is shut off by the MRS or X10 signal input through the external terminal, the brake transistor will turn off and the regenerative brake duty will decrease.
- When the terminal assignment is changed using **Pr.178 to Pr.182** and **Pr.185 to Pr.189 (Input terminal function selection)**, wiring may be mistaken due to different terminal name and signal contents, or may affect other functions. Set parameters after confirming the function of each terminal.

◆ Regenerative brake duty warning output and the warning signal (RBP signal)

- When the regenerative brake duty reaches 85% of the **Pr.70** setting, "RB" is indicated on the operation panel and the Regenerative brake prealarm (RBP) signal is output. When it reaches 100% of the **Pr.70** setting, it will become regenerative overvoltage (E.OV[]).
- The inverter output is not shut off with the warning signal.
- For the RBP signal output, set "7" (positive logic) or "107" (negative logic) in any parameter from **Pr.190 to Pr.196 (Output terminal function selection)** to assign the function.

100%: Regeneration overvoltage protection operation value

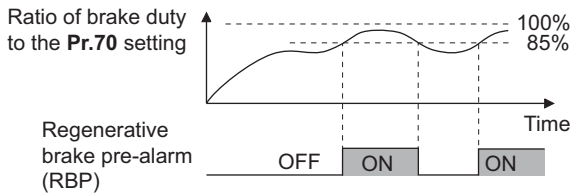

NOTE

- When **Pr.30** = "0 (initial value)", "RB" is not indicated.
- Changing the terminal assignment using **Pr.190 to Pr.196 (Output terminal function selection)** may affect the other functions. Set parameters after confirming the function of each terminal.

◆ Connection of a brake resistor other than the FR-ABR, MRS type, and MYS type

A brake resistor can be used with the FR-D820-0.4K-025 or higher, the FR-D840-0.4K-012 or higher, the FR-D820S-0.4K-025 or higher, and the FR-D810W-0.4K-025 or higher.

Use a brake resistor that has resistance and power consumption values higher than the following. Also, the brake resistor must have a sufficient capacity to consume the regenerative power.

Voltage class	Inverter	Minimum resistance (Ω)	Power consumption (kW)
100 V class	FR-D810W-0.4K-025*1	100	1.5
	FR-D810W-0.75K-042*1	80	1.9
200 V class	FR-D820-0.4K-025*1	100	1.5
	FR-D820-0.75K-042*1	80	1.9
	FR-D820-1.5K-070	60	2.5
	FR-D820-2.2K-100	60	2.5
	FR-D820-3.7K-165	40	3.8
	FR-D820-5.5K-238	25	6.1
	FR-D820-7.5K-318	20	7.6
	FR-D820-11K-450	13	11.7
	FR-D820-15K-580	9	16.9
	FR-D820S-0.4K-025*1	100	1.5
	FR-D820S-0.75K-042*1	80	1.9
	FR-D820S-1.5K-070	60	2.5
FR-D820S-2.2K-100	60	2.5	
400 V class	FR-D840-0.4K-012	371	1.6
	FR-D840-0.75K-022	236	2.4
	FR-D840-1.5K-037	205	2.8
	FR-D840-2.2K-050	180	3.2
	FR-D840-3.7K-081	130	4.4
	FR-D840-5.5K-120	94	6.1
	FR-D840-7.5K-163	67	8.6
	FR-D840-11K-230	49	11.8
	FR-D840-15K-295	36	16

*1 The resistance should be 200 Ω or more at 100% ED. The following shows the brake duty when the resistance is less than 200 Ω.

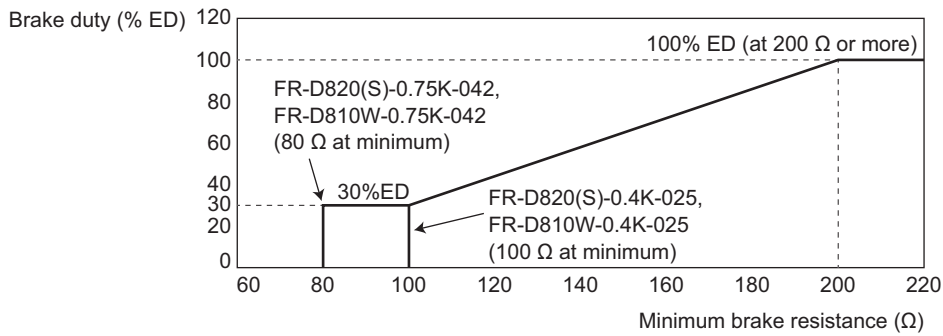

Set parameters as follows:

- **Pr.30 Regenerative function selection** = "1"
- Set **Pr.70 Special regenerative brake duty** according to the amount and frequency of the regenerative driving, and make sure that the resistor can consume the regenerative power properly.
- When the regenerative brake transistor is damaged, install a thermal relay to prevent overheat and burnout of the brake resistor. (Refer to the Instruction Manual (Connection) to install a thermal relay.) Properly select a thermal relay according to the regenerative driving frequency or the rated power or resistance of the brake resistor.

⚠ CAUTION

- If the resistor selection is incorrect, overcurrent may damage the inverter built-in brake transistor. Besides, the resistor may be burned due to overheat.
- If the selection of the thermal relay is incorrect, the resistor may be burned due to overheat.

« Parameters referred to »

Pr.57 Restart coasting time [page 307](#), [page 312](#)

Pr.178 to Pr.182 and Pr.185 to Pr.189 (Input terminal function selection) [page 252](#)

Pr.190 to Pr.196 (Output terminal function selection) [page 226](#)

14.9 Regeneration avoidance function

The regenerative status can be detected and avoided by raising the frequency.

- The operation frequency is automatically increased to prevent the regenerative operations. This function is useful when a load is forcibly rotated by another fan in the duct.

Pr.	Name	Initial value		Setting range	Description
882 G120	Regeneration avoidance operation selection	0		0	The regeneration avoidance function is disabled.
				1	The regeneration avoidance function is always enabled.
				2	The regeneration avoidance function is enabled only during constant-speed operation.
883 G121	Regeneration avoidance operation level	100/200 V class	400 VDC	300 to 800 V	Set the bus voltage level to operate the regeneration avoidance operation. When the bus voltage level is set low, it will be harder to generate overvoltage error, but actual deceleration time will be longer. Set the setting value higher than the (power supply voltage $\times \sqrt{2}^{*1}$) value.
		400 V class	780 VDC		
885 G123	Regeneration avoidance compensation frequency limit value	6 Hz		0 to 45 Hz	Set the limit value for frequency to rise when the regeneration avoidance function is activated.
				9999	The frequency limit is disabled.
886 G124	Regeneration avoidance voltage gain	100%		0% to 200%	Adjust the response during the regeneration avoidance operation. Increasing the setting improves the response to change in the bus voltage. However, the output frequency may become unstable. If setting a smaller value in Pr.886 does not suppress the vibration, set a smaller value in Pr.665 .
665 G125	Regeneration avoidance frequency gain	100%		0% to 200%	

*1 For a single-phase 100 V power input model, power input voltage $\times 2 \times \sqrt{2}$.

◆ Regeneration avoidance operation (Pr.882, Pr.883)

- When the regenerative voltage increases, the DC bus voltage will rise, which may cause an overvoltage fault (E.OV[]). The regenerative status can be avoided by detecting this rise of bus voltage, and raising the frequency when the bus voltage level reaches or exceeds **Pr.883 Regeneration avoidance operation level**.
- The regeneration avoidance operation can be selected to operate constantly or operate only during constant speed.
- The regeneration avoidance function is enabled by setting "1 or 2" in **Pr.882 Regeneration avoidance operation selection**.

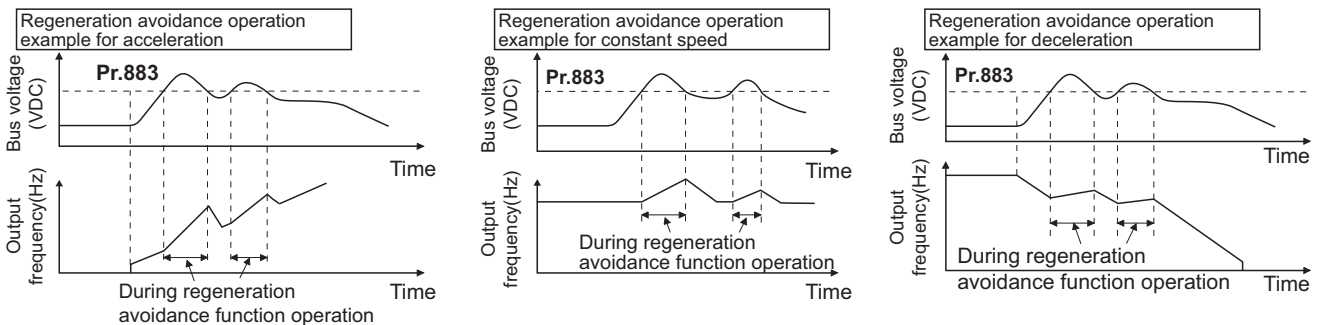

NOTE

- The slope of frequency rising or lowering by the regeneration avoidance operation will change depending on the regenerative status.
- The DC bus voltage of the inverter will be approximately $\sqrt{2}$ times of the normal input voltage (twice of the input voltage for the 100 V class).
The bus voltage is approx. 311 VDC at an input voltage of 220 VAC (283 VDC at 100 VAC and 622 VDC at 440 VAC). However, it may vary depending on the input power supply waveform.
- Make sure that the setting value of **Pr.883** will not get under DC bus voltage level. The frequency will rise with operation of the regeneration avoidance function even during operation other than the regenerative operation.
- The stall prevention (overvoltage) (OLV) will be activated only during deceleration, stopping the lowering of output frequency. On the other hand, the regeneration avoidance function will be activated constantly (**Pr.882** = "1") or only at constant speed (**Pr.882** = "2"), and raise the frequency depending on the amount of regeneration.
- When the motor becomes unstable due to the stall prevention (overcurrent) (OLC) during the regeneration avoidance operation, increase the deceleration time or set a lower value in **Pr.883**.

◆ Limiting the regeneration avoidance operation frequency (Pr.885)

- It is possible to assign a limit to the output frequency corrected (rise) by the regeneration avoidance operation.
- Limit of the frequency is output frequency (frequency before regeneration avoidance operation) + **Pr.885 Regeneration avoidance compensation frequency limit value** for during acceleration and constant speed. During deceleration, when the frequency increases due to the regeneration avoidance operation and reaches the limit value, the limit value will be retained until the output frequency is reduced to be the half the **Pr.885** setting.
- The regeneration avoidance operation frequency is limited at the setting of **Pr.1 Maximum frequency**.
- When **Pr.885** = "9999", the regeneration avoidance compensation frequency limit is disabled.
- Set the frequency around the motor rated slip frequency. Increase the setting value if the overvoltage protection function (E.OV[]) is activated at the start of deceleration.

$$\text{Rated motor slip frequency} = \frac{\text{Synchronized speed at the time of base frequency} - \text{rated rotation speed}}{\text{Synchronized speed at the time of base frequency}} \times \text{Rated motor frequency}$$

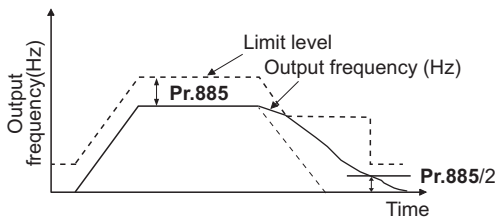

◆ Adjusting the regeneration avoidance operation (Pr.665, Pr.886)

- If the frequency becomes unstable during regeneration avoidance operation, decrease the setting of **Pr.886 Regeneration avoidance voltage gain**. On the other hand, if an overvoltage fault occurs due to a sudden regeneration, increase the setting.
- If setting a smaller value in **Pr.886** does not suppress the vibration, set a smaller value in **Pr.665 Regeneration avoidance frequency gain**.

NOTE

- During the regeneration avoidance operation, the stall prevention (overvoltage) "OLV" is displayed and the Overload warning (OL) signal is output. **Pr.156 Stall prevention operation selection** can be used to set whether to continue the operation when the OL signal is output. Use **Pr.157 OL signal output timer** to set the OL signal output timing.
- The stall prevention is enabled even during regeneration avoidance operation.
- The regeneration avoidance function cannot decrease the actual deceleration time for the motor to stop. Since the actual deceleration time is determined by the regenerative power consumption performance, consider using a regeneration unit (FR-BU2, BU, FR-BU, FR-XC, FR-HC2) or brake resistor (FR-ABR, etc.) to decrease the deceleration time.
- When using a regeneration unit (FR-BU2, BU, FR-BU, FR-XC, FR-HC2) or brake resistor (FR-ABR, etc.) to consume the regenerative power at constant speed, set **Pr.882** = "0 (initial value)" (the regeneration avoidance function is disabled). When consuming the regenerative power at the time of deceleration with the regeneration unit, etc., set **Pr.882** = "2" (enables regeneration avoidance function only at the constant speed).

Parameters referred to

Pr.1 Maximum frequency  [page 191](#)

Pr.8 Deceleration time  [page 191](#)

Pr.22 Stall prevention operation level  [page 195](#)

14.10 Increased magnetic excitation deceleration



Increase the loss in the motor by increasing the magnetic flux during deceleration. The deceleration time can be reduced by suppressing the stall prevention (overvoltage) (oL).

The deceleration time can be reduced without using a brake resistor. (When a brake resistor is used, the duty can be reduced.)

Pr.	Name	Initial value	Setting range	Description
660 G130	Increased magnetic excitation deceleration operation selection	0	0	Without the increased magnetic excitation deceleration function
			1	With the increased magnetic excitation deceleration function
661 G131	Magnetic excitation increase rate	9999	0% to 40%	Set the increase of excitation.
			9999	The magnetic excitation increase rate is 10%.
662 G132	Increased magnetic excitation current level	100%	0% to 200%	The increased magnetic excitation rate is automatically lowered when the output current reaches or exceeds the setting value during increased magnetic excitation deceleration.

◆ Setting of increased magnetic excitation rate (Pr.660, Pr.661)

- To enable the increased magnetic excitation deceleration, set **Pr.660 Increased magnetic excitation deceleration operation selection** = "1".
- Set the amount of excitation increase in **Pr.661 Magnetic excitation increase rate**.
- Increased magnetic excitation deceleration will be disabled when **Pr.661** = "0". When "8888 or 9999" is not set in **Pr.19** under V/F control, increased magnetic excitation deceleration will be enabled even when **Pr.661** = "0".
- When the DC bus voltage reaches or exceeds the increased magnetic excitation deceleration operation level during the deceleration, excitation is increased in accordance with the setting value in **Pr.661**.
- The increased magnetic excitation deceleration will continue even if the DC bus voltage goes under the increased magnetic excitation deceleration operation level during increased magnetic excitation deceleration.

Inverter	Increased magnetic excitation deceleration operation level
100/200 V class	340 V
400 V class	680 V

- When the stall prevention (overvoltage) occurs during the increased magnetic excitation deceleration operation, increase the deceleration time or raise the setting value of **Pr.661**. When the stall prevention (overcurrent) occurs, increase the deceleration time or lower the setting value of **Pr.661**.
- Increased magnetic excitation deceleration is enabled under V/F control and Advanced magnetic flux vector control.

NOTE

- Increased magnetic excitation deceleration will be disabled in the following conditions:
Under PM sensorless vector control, automatic restart after instantaneous power failure, power failure stop, and Optimum excitation control.

◆ Overcurrent prevention function (Pr.662)

- The increased magnetic excitation rate is lowered automatically when the output current reaches or exceeds the level set in **Pr.662** during increased magnetic excitation deceleration.
- When the inverter protective function (E.OC[], E.THT) is activated due to increased magnetic excitation deceleration, adjust the level set in **Pr.662**.
- The overcurrent prevention function is disabled when **Pr.662** = "0".

NOTE

- When the level set in **Pr.662** is more than the stall prevention operation level, the overcurrent preventive function is activated at the level set in **Pr.22 (Pr.48), Pr.23, or Pr.66**. (When **Pr.22 (Pr.48)** = "0" or the stall prevention operation is disabled by **Pr.156** setting, the overcurrent preventive function is activated at the level set in **Pr.662**.)

Parameters referred to

Pr.22 Stall prevention operation level  [page 195](#)

Pr.60 Energy saving control selection  [page 333](#)

Pr.162 Automatic restart after instantaneous power failure selection  [page 307](#), [page 312](#)

Pr.261 Power failure stop selection  [page 318](#)

14.11 Slip compensation



Under V/F control, the slip of the motor is estimated from the inverter output current to maintain the rotation of the motor constant.

Pr.	Name	Initial value	Setting range	Description
245 G203	Rated slip	9999	0.01% to 50%	Set the rated motor slip.
			0, 9999	No slip compensation
246 G204	Slip compensation time constant	0.5 s	0.01 to 10 s	Set the response time of the slip compensation. Reducing the value improves the response, but the regenerative overvoltage (E.OV[]) error is more likely to occur with a larger load inertia.
247 G205	Constant output range slip compensation selection	9999	0	No slip compensation in the constant power range (frequency range higher than the frequency set in Pr.3).
			9999	Slip compensation is performed in the constant power range.

- Calculate the rated motor slip and set the value in **Pr.245** to enable slip compensation. Slip compensation is not performed when **Pr.245** = "0 or 9999".

$$\text{Rated slip} = \frac{\text{Synchronized speed at the time of base frequency} - \text{rated rotation speed}}{\text{Synchronized speed at the time of base frequency}} \times 100 [\%]$$

NOTE

- When the slip compensation is performed, the output frequency may become larger than the set frequency. Set **Pr.1 Maximum frequency** higher than the set frequency.
- Slip compensation will be disabled in the following conditions:
Stall prevention (OLC, OLV) operation, regeneration avoidance operation, auto tuning, and acceleration/deceleration

Parameters referred to

Pr.1 Maximum frequency [page 191](#)

Pr.3 Base frequency [page 329](#)

14.12 Speed smoothing control



The output current (torque) of the inverter sometimes becomes unstable due to vibration caused by mechanical resonance. Such vibration can be suppressed by reducing fluctuation of the output current (torque) by changing the output frequency.

Pr.	Name	Initial value	Setting range	Description
653 G410	Speed smoothing control	0%	0% to 200%	Check the effect by increasing and decreasing the value at around 100%.
654 G411	Speed smoothing cutoff frequency	20 Hz	0 to 120 Hz	Set the minimum frequency for the torque variation cycle.

◆ Control block diagram

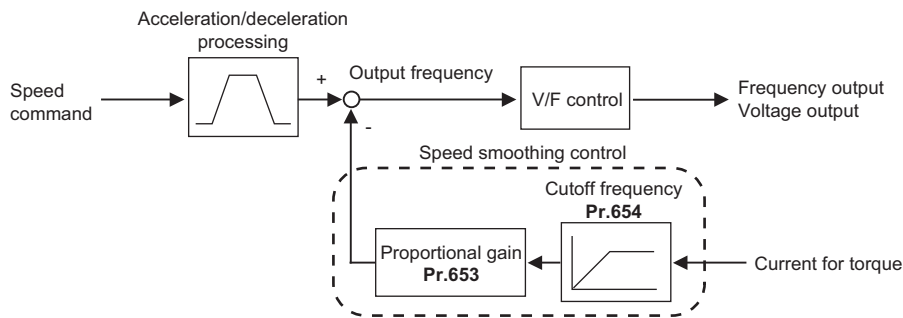

◆ Setting method

- When vibration caused by mechanical resonance occurs, set 100% in **Pr.653 Speed smoothing control**, perform operation at the frequency with the largest vibration, and check if the vibration is suppressed after few seconds.
- If the setting is not effective, gradually increase the value set in **Pr.653** and repeat the operation to check the effect to determine the most effective value (**Pr.653**).
- If the vibration increases by increasing the value in **Pr.653**, decrease the value in **Pr.653** from 100% to check the effect.
- When the vibrational frequency at which mechanical resonance occurs (during fluctuation of torque, speed, or converter output voltage) is measured using an instrument such as a tester, set 1/2 to 1 times of the vibrational frequency in **Pr.654 Speed smoothing cutoff frequency**. (Setting the resonance frequency range mitigates vibration more effectively.)

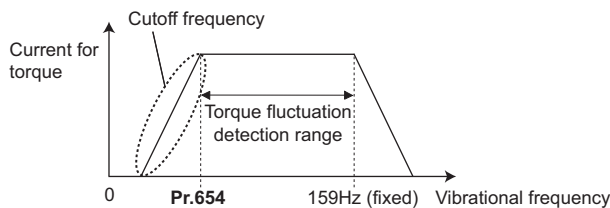

NOTE

- Depending on the equipment, the vibration may not be suppressed sufficiently or the setting is not effective.

14.13 Vibration suppression control



If the motor rotation speed becomes unstable due to cyclic load vibration, such vibration can be suppressed.

Pr.	Name	Initial value	Setting range	Description
532 G225	Vibration suppression mode selection	9999	1, 2	Vibration suppression control enabled Set the number of vibration per motor rotation.
			9999	Vibration suppression control disabled
533 G226	Vibration suppression response adjustment	9999	0% to 200%	Adjust the response level of the vibration suppression control. The reference value is 100%.
			9999	0%
534 G227	Maximum vibration suppression frequency	9999	0 to 400 Hz	Set the upper limit of the frequency command to perform the vibration suppression control.
			9999	The vibration suppression control is performed with a frequency command equal to or lower than Pr.84 Rated motor frequency . ^{*1}
535 G228	Minimum vibration suppression frequency	9999	0 to 400 Hz	Set the lower limit of the frequency command to perform the vibration suppression control.
			9999	The vibration suppression control is performed with a frequency command equal to or higher than 10% of Pr.84 Rated motor frequency .
707 C107	Motor inertia (integer)	9999	10 to 999, 9999	Set the motor inertia. 9999: Inverter internal data is used.
724 C108	Motor inertia (exponent)	9999	0 to 7, 9999	

*1 If the **Pr.84** setting value is higher than the upper limit of the effective range of this function, the upper limit of the effective range is used as the maximum vibration suppression frequency. The upper limit of the effective range is calculated by the following formula using the setting values of **Pr.81 Number of motor poles** and **Pr.532 Vibration suppression mode selection**.

$$\text{Upper limit of the effective range} = 7200 \text{ [r/min]} \times \frac{\text{Pr.81}}{120} \times \frac{1}{\text{Pr.532}}$$

- To enable the vibration suppression control, set "1 or 2" in **Pr.532 Vibration suppression mode selection**.
- This function is enabled when the frequency command is equal to or higher than 10% of the **Pr.84 Rated motor frequency setting**.
- Set **Pr.533 Vibration suppression response adjustment** = 100%. When adjusting the response level of the vibration suppression control, change the **Pr.533** setting from 100%. Setting this parameter higher speeds up the response, but setting this too high makes the motor rotation speed unstable.
- If the motor inertia is known, set **Pr.707 Motor inertia (integer)** and **Pr.724 Motor inertia (exponent)**. (Refer to [page 274](#))
- To set the frequency command range to perform the vibration suppression control, use **Pr.534 Maximum vibration suppression frequency** and **Pr.535 Minimum vibration suppression frequency**.

NOTE

- When the **Pr.535** setting is equal to or higher than the **Pr.534** setting, vibration suppression control is performed only for operation at the frequency set in **Pr.534**.
- In the low-speed range, torque ripples or uneven rotation occur. Adjust the **Pr.535** setting as required.

15 Checking and Clearing of Settings

15.1 Parameter clear / All parameter clear

Point

- Set "1" in **Pr.CL Parameter clear** or **ALLC All parameter clear** to initialize the parameter. (The parameter cannot be cleared when **Pr.77 Parameter write selection** = "1".)
- Pr.CL does not clear calibration parameters or the terminal function selection parameters.
- Refer to the parameter list on [page 360](#) for parameters cleared with this operation.

15

Operating procedure

- 1.** Turning ON the power of the inverter
The operation panel is in the monitor mode.
- 2.** Changing the operation mode
Press the HAND/AUTO key to choose the PU operation mode. The HAND LED turns ON.
- 3.** Selecting the parameter setting mode
Press the MODE key to choose the parameter setting mode. (The parameter number read previously appears.)
- 4.** Selecting the parameter
Turn the setting dial until "Pr.CL" appears for Parameter clear or "ALLC" for All parameter clear, and press the SET key. "0 (initial value)" appears.
- 5.** Parameter clear
Turn the setting dial to change the value to "1". Press the SET key to confirm the setting. "1" and "Pr.CL" ("ALLC") are displayed alternately after parameters are cleared.
 - Turn the setting dial to read another parameter.
 - Press the SET key to show the setting again.
 - Press the SET key twice to show the next parameter.

Setting	Description	
	Pr.CL Parameter clear	ALLC All parameter clear
0	Initial display (Parameters are not cleared.)	
1	The settings of parameters except for calibration parameters and terminal function selection parameters are initialized.	The settings of all the parameters, including calibration parameters and terminal function selection parameters, are initialized.

NOTE

- "1" and "Er4" are displayed alternately when the operation mode is other than the PU operation mode.
 - 1) Press the HAND/AUTO key.
The HAND LED turns ON, and "1" appears on the monitor. (When **Pr.79** = "0 (initial value)")
 - 2) Press the SET key to clear the parameter.
- Parameters can be cleared during an inverter stop or while a protective function is activated. Writing error occurs if parameter clear is attempted while the inverter is running.
- To clear the parameter, the inverter must be in the PU operation mode even if "2" is set in **Pr.77**.
- For availability of Parameter clear or All parameter clear operation for each parameter, refer to the parameter list on [page 360](#).

15.2 List of parameters changed from the initial values

Parameters changed from their initial values can be displayed.

Operating procedure

- 1.** Turning ON the power of the inverter
The operation panel is in the monitor mode.
- 2.** Selecting the parameter setting mode
Press the MODE key to choose the parameter setting mode. (The parameter number read previously appears.)
- 3.** Selecting the parameter
Turn the setting dial until "Pr.CH" (Initial value change list) appears, and set the SET key.
"P.---" blinks and then remains displayed.
- 4.** Checking the initial value change list
Turn the setting dial after blinking stops to display the parameter numbers that have been changed from their initial values in order.
 - When the SET key is pressed with a changed parameter displayed, the setting can be changed. (Parameter numbers are no longer displayed in the list when they are returned to their initial values.)
Turn the setting dial to display another changed parameter.
 - The indication returns to "P.---" when the last changed parameter is displayed.

NOTE

- Calibration parameters (**C1 (Pr.901) to C7 (Pr.905), C42 (Pr.934) to C45 (Pr.935)**) are not displayed even when these are changed from the initial settings.
 - Only the simple mode parameters are displayed when the simple mode is set (**Pr.160 = "9999"**).
 - Only user groups are displayed when user groups are set (**Pr.160 = "1"**).
 - **Pr.160** is displayed independently of whether the setting value is changed or not.
-

15.3 Fault history clear

◆ Fault history clearing procedure

Point

- Set **Er.CL Fault history clear** = "1" to clear the fault history.

Operating procedure

- 1.** Turning ON the power of the inverter
The operation panel is in the monitor mode.
- 2.** Selecting the parameter setting mode
Press the MODE key to choose the parameter setting mode. (The parameter number read previously appears.)
- 3.** Selecting the parameter
Turn the setting dial until "ER.CL" (Fault history clear) appears. Press the SET key to read the present set value. "0" (initial value) appears.
- 4.** Fault history clear
Turn the setting dial to change the value to "1". Press the SET key to start clearing.
"1" and "ER.CL" are displayed alternately after the fault history is cleared.
 - Turn the setting dial to read another parameter.
 - Press the SET key to show the setting again.
 - Press the SET key twice to show the next parameter.

15.4 Changing the parameter initial value group

The parameter initial value group can be changed.

Operating procedure

- 1.** Turning ON the power of the inverter
The operation panel is in the monitor mode.
- 2.** Changing the operation mode
Press the HAND/AUTO key to choose the PU operation mode. The HAND LED turns ON.
- 3.** Selecting the parameter setting mode
Press the MODE key to choose the parameter setting mode. (The parameter number read previously appears.)
- 4.** Selecting the parameter
Turn the setting dial until "PR.GR" (Parameter initial value group setting) appears. Press the SET key to read the present set value. "1" or "2" appears.
- 5.** Changing the parameter initial value group
Turn the setting dial to change the value. Press the SET key to confirm the setting. The setting value and "PR.GR" are displayed alternately after the setting is completed.
 - Turn the setting dial to read another parameter.
 - Press the SET key to show the setting again.
 - Press the SET key twice to show the next parameter.

NOTE

- The parameter initial value group can be changed during an inverter stop.
 - All parameter clear is performed when the parameter initial value group is changed.
 - When the parameter initial value group is changed while FR Configurator2 is used, the message "The inverter in the system setting is different from the connected inverter." may appear on FR Configurator2.
 - For the parameter initial value group, refer to [page 46](#).
-

16 Appendix

Appendix provides the reference information for use of this product.
Refer to the information as required.

16.1 For customers replacing the conventional model with this inverter

16.1.1 Replacement of the FR-D700 series

◆ Differences and compatibility with the FR-D700 series

Item		FR-D800	FR-D700
Applicable rating		Two ratings (SLD/ND) ND rating only for the single-phase 100/200 V power input models	Not available (ND only)
Overload current rating	SLD rating	110% 60 s, 120% 3 s (inverse-time characteristics) at surrounding air temperature of 40°C	Not available
	ND rating	150% 60 s, 200% 0.5 s (inverse-time characteristics) at surrounding air temperature of 50°C	150% 60 s, 200% 0.5 s (inverse-time characteristics)
Built-in brake transistor		Provided in FR-D820-0.4K-025 to 15K-580, FR-D840-0.4K-012 to 15K-295, FR-D820S-0.4K-025 to 2.2K-100, FR-D810W-0.4K-025 and 0.75K-042	Provided in FR-D720-0.4K to 15K, FR-D740-0.4K to 15K, FR-D720S-0.4K to 2.2K, FR-D710W-0.4K and 0.75K
Protective structure		Open type IP20 (for IEC 60529 only)	Enclosed type IP20 (for JEM 1030 only)
Control method	—	Soft-PWM control / High carrier frequency PWM control	
	V/F control	Available	
	Advanced magnetic flux vector control	Available	Not available
	General-purpose magnetic flux vector control	Not available	Available
	PM sensorless vector control	Available	Not available
Control mode	Speed control	Available	
Output frequency		Induction motor: 0.2 to 590 Hz (The upper-limit frequency is 400 Hz under Advanced magnetic flux vector control.) PM motor: 0.2 to 400 Hz (not operable at a frequency higher than the maximum motor frequency)	0.2 to 400 Hz
Frequency setting resolution	Terminal 2	0.015 Hz / 0 to 60 Hz (0 to 10 V / 12 bits) 0.03 Hz / 0 to 60 Hz (0 to 5 V / 11 bits) 0.03 Hz / 0 to 60 Hz (0 to 20 mA / 11 bits)	0.06 Hz / 0 to 60 Hz (0 to 10 V / 10 bits) 0.12 Hz / 0 to 60 Hz (0 to 5 V / 9 bits)
	Terminal 4	0.015 Hz / 0 to 60 Hz (0 to 10 V / 12 bits) 0.03 Hz / 0 to 60 Hz (0 to 5 V / 11 bits) 0.03 Hz / 0 to 60 Hz (0 to 20 mA / 11 bits)	0.06 Hz / 60 Hz (0 to 10 V / 10 bits) 0.12 Hz / 60 Hz (0 to 5 V / 9 bits) 0.06 Hz / 60 Hz (0 to 20 mA / 10 bits)
Output signal	Via terminal FM (pulse output)	Not available	1440 pulses/s at full scale
	Via terminal AM (analog output)	0 to +10 V / 12 bits	Not available
Operation panel	Standard equipment	Operation panel installed as standard (not removable). 7-segment LED 4-digit display.	
	Option	Enclosure surface operation panel (FR-PA07) LCD operation panel (FR-LU08) Parameter unit (FR-PU07(BB))	Enclosure surface operation panel (FR-PA07) Parameter unit (FR-PU07)
Main circuit terminals		R, S, T, U, V, W, P, PR, N, P1, earth (ground) (screw terminal)	

Item		FR-D800	FR-D700
Control circuit terminal	Shape of terminal block	Spring clamp type	
	Contact input	5	
	Analog input	2	
	Relay output	1	
	Open collector output	2	1
	Pulse output	Not available	1
	Analog output	1	Not available
	Safety input/output	S1, S2, PC, So (SO), SoC (SOC)	S1, S2, SC, So (SO)
Communication	RS-485	PU connector / RS-485 terminals Mitsubishi inverter protocol, MODBUS RTU	PU connector Mitsubishi inverter protocol, MODBUS RTU
	USB	USB Type-C connector: USB bus power available (Maximum SCCR: 500 mA)	Not available
Surrounding air temperature		-20°C to +60°C (non-freezing) SLD rating: The rated current must be reduced at a temperature above 40°C. ND rating: The rated current must be reduced at a temperature above 50°C.	-10°C to +50°C (non-freezing)
Storage temperature		-40°C to +70°C	-20°C to +65°C
Machine speed display		The rotation speed is displayed when Pr.53 = "1". The machine speed is displayed when Pr.53 = "4". Use Pr.37 and Pr.505 to set the reference for machine speed.	The machine speed is displayed when Pr.37 ≠ "0".
Built-in potentiometer switching		Pr.146 unavailable (PA02 not supported)	Pr.146 available
Control mode selection		V/F control when "40" is set in Pr.800 .	V/F control when "9999" is set in Pr.80 .
MRS input selection		Use Pr.17 to change the input specifications of the MRS and X10 signals.	Use Pr.17 to change the input specification of the MRS signal.
Offline auto tuning		Set Pr.96 = "11" to enable offline auto tuning for V/F control (frequency search for the automatic restart after instantaneous power failure).	Set Pr.96 = "21" to enable offline auto tuning for V/F control (frequency search for the automatic restart after instantaneous power failure).
Applicable motor		Offline auto tuning is enabled regardless of the Pr.71 setting. Set Pr.71 to a value whose last digit is 3 to change the setting range of the motor constant.	Set Pr.71 to a value whose last digit is 3 to enable offline auto tuning.
		Set "10" for the constant-torque motor.	Set "1" for the constant-torque motor.

◆ Installation precautions

- Installation/removal procedures of the front cover and wiring cover are different. (Refer to the Instruction Manual (Connection).)

◆ Wiring instructions

- To use the PU connector, note that wiring methods are different. (Refer to the Instruction Manual (Connection).)

◆ Copying parameter settings

- The FR-D700 series' parameter settings can be easily copied to the FR-D800 series by using the setup software (FR Configurator2). (Not supported by the setup software FR-SW3-SETUP or older.)

16.2 Specification comparison between PM sensorless vector control and induction motor control

Item	PM sensorless vector control	Induction motor control
Applicable motor	IPM motor or PM motor ^{*1}	Induction motor ^{*1}
Starting torque	50%	200% (FR-D820-3.7K-165 or lower, FR-D840-3.7K-081 or lower, FR-D820S-2.2K-100 or lower, FR-D810W-0.75K-042 or lower) and 150% (FR-D820-5.5K-238 or higher, FR-D840-5.5K-120 or higher) under Advanced magnetic flux vector control
Startup delay	Startup delay of about 0.1 s for magnetic pole position detection.	No startup delay.
Operation during coasting	While the motor is coasting, potential is generated across motor terminals.	While the motor is coasting, potential is not generated across motor terminals.

*1 The rated motor current should be equal to or less than the inverter rated current.

If a motor with substantially low rated current compared with the inverter rated current is used, speed accuracy may deteriorate due to torque ripples, etc. Set the rated motor current to about 40% or higher of the inverter rated current. (For details on the inverter rated current, refer to the inverter rated specifications in the Instruction Manual (Connection).)

NOTE

- Before wiring, make sure that the motor is stopped. Otherwise you may get an electric shock.
- Never connect a PM motor to a commercial power supply.
- No slippage occurs with a PM motor because of its characteristic. If a PM motor, which took over an induction motor, is driven at the same speed as for the general-purpose motor, the running speed of the PM motor becomes faster by the amount of the general-purpose motor's slippage. Adjust the speed command to run the PM motor at the same speed as the induction motor, as required.

16.3 Parameters (functions) and instruction codes under different control methods

- *1 Instruction codes are used to read and write parameters in accordance with communication (such as the Mitsubishi inverter protocol). (For details of communication, refer to the Instruction Manual (Communication).)
- *2 Function availability under each control method is shown as follows:
 ○: Available
 ×: Not available
 Δ: Available with some restrictions
- *3 For Parameter copy, Parameter clear, and All parameter clear, ○ indicates the function is available, and × indicates the function is not available.
- *4 Communication parameters that are not cleared by parameter clear or all parameter clear (H5A5A or H55AA) via communication. (For details of communication, refer to the Instruction Manual (Communication).)
- *5 When a communication option is installed, parameter clear (lock release) during password lock (Pr.297 Password lock/unlock ≠ "9999") can be performed only from the communication option.

Notation





Mark	Description
3-phase	Available for the three-phase power input model.

Pr.	Name	Instruction code ^{*1}			Control method ^{*2}			Parameter		
		Read	Write	Extended	V/F	Magnetic flux	PM	Copy ^{*3}	Clear ^{*3}	All clear ^{*3}
0	Torque boost	00	80	0	○	×	×	○	○	○
1	Maximum frequency	01	81	0	○	○	○	○	○	○
2	Minimum frequency	02	82	0	○	○	○	○	○	○
3	Base frequency	03	83	0	○	×	×	○	○	○
4	Multi-speed setting (high speed)	04	84	0	○	○	○	○	○	○
5	Multi-speed setting (middle speed)	05	85	0	○	○	○	○	○	○
6	Multi-speed setting (low speed)	06	86	0	○	○	○	○	○	○
7	Acceleration time	07	87	0	○	○	○	○	○	○
8	Deceleration time	08	88	0	○	○	○	○	○	○
9	Electronic thermal O/L relay	09	89	0	○	○	○	○	○	○
10	DC injection brake operation frequency	0A	8A	0	○	○	○	○	○	○
11	DC injection brake operation time	0B	8B	0	○	○	○	○	○	○
12	DC injection brake operation voltage	0C	8C	0	○	○	×	○	○	○
13	Starting frequency	0D	8D	0	○	○	○	○	○	○
14	Load pattern selection	0E	8E	0	○	×	×	○	○	○
15	Jog frequency	0F	8F	0	○	○	○	○	○	○
16	Jog acceleration/deceleration time	10	90	0	○	○	○	○	○	○
17	MRS/X10 terminal input selection	11	91	0	○	○	○	○	○	○
18	High speed maximum frequency	12	92	0	○	○	○	○	○	○
19	Base frequency voltage	13	93	0	○	×	×	○	○	○
20	Acceleration/deceleration reference frequency	14	94	0	○	○	○	○	○	○
22	Stall prevention operation level (Torque limit level)	16	96	0	○	○	○	○	○	○
23	Stall prevention operation level compensation factor at double speed	17	97	0	○	○	×	○	○	○
24	Multi-speed setting (speed 4)	18	98	0	○	○	○	○	○	○
25	Multi-speed setting (speed 5)	19	99	0	○	○	○	○	○	○
26	Multi-speed setting (speed 6)	1A	9A	0	○	○	○	○	○	○
27	Multi-speed setting (speed 7)	1B	9B	0	○	○	○	○	○	○
29	Acceleration/deceleration pattern selection	1D	9D	0	○	○	○	○	○	○
30	Regenerative function selection	1E	9E	0	○	○	○	○	○	○
31	Frequency jump 1A	1F	9F	0	○	○	○	○	○	○
32	Frequency jump 1B	20	A0	0	○	○	○	○	○	○
33	Frequency jump 2A	21	A1	0	○	○	○	○	○	○
34	Frequency jump 2B	22	A2	0	○	○	○	○	○	○
35	Frequency jump 3A	23	A3	0	○	○	○	○	○	○





Pr.	Name	Instruction code ^{*1}			Control method ^{*2}			Parameter		
		Read	Write	Extended	V/F	Magnetic flux	PM	Copy ^{*3}	Clear ^{*3}	All clear ^{*3}
36	Frequency jump 3B	24	A4	0	○	○	○	○	○	○
37	Speed display	25	A5	0	○	○	○	○	○	○
40	RUN key rotation direction selection	28	A8	0	○	○	○	○	○	○
41	Up-to-frequency sensitivity	29	A9	0	○	○	○	○	○	○
42	Output frequency detection	2A	AA	0	○	○	○	○	○	○
43	Output frequency detection for reverse rotation	2B	AB	0	○	○	○	○	○	○
44	Second acceleration/deceleration time	2C	AC	0	○	○	○	○	○	○
45	Second deceleration time	2D	AD	0	○	○	○	○	○	○
46	Second torque boost	2E	AE	0	○	×	×	○	○	○
47	Second V/F (base frequency)	2F	AF	0	○	×	×	○	○	○
48	Second stall prevention operation level	30	B0	0	○	○	×	○	○	○
51	Second electronic thermal O/L relay	33	B3	0	○	○	○	○	○	○
52	Operation panel main monitor selection	34	B4	0	○	○	○	○	○	○
53	Frequency / rotation speed unit switchover	35	B5	0	○	○	○	○	○	○
55	Frequency monitoring reference	37	B7	0	○	○	○	○	○	○
56	Current monitoring reference	38	B8	0	○	○	○	○	○	○
57	Restart coasting time	39	B9	0	○	○	○	○	○	○
58	Restart cushion time	3A	BA	0	○	○	×	○	○	○
59	Remote function selection	3B	BB	0	○	○	○	○	○	○
60	Energy saving control selection	3C	BC	0	○	○	×	○	○	○
65	Retry selection	41	C1	0	○	○	○	○	○	○
66	Stall prevention operation reduction starting frequency	42	C2	0	○	○	×	○	○	○
67	Number of retries at fault occurrence	43	C3	0	○	○	○	○	○	○
68	Retry waiting time	44	C4	0	○	○	○	○	○	○
69	Retry count display erase	45	C5	0	○	○	○	○	○	○
70	Special regenerative brake duty	46	C6	0	○	○	○	○	○	○
71	Applied motor	47	C7	0	○	○	○	○	○	○
72	PWM frequency selection	48	C8	0	○	○	○	○	○	○
73	Analog input selection	49	C9	0	○	○	○	○	×	○
74	Input filter time constant	4A	CA	0	○	○	○	○	○	○
75	Reset selection/disconnected PU detection/PU stop selection	4B	CB	0	○	○	○	○	×	×
77	Parameter write selection	4D	CD	0	○	○	○	○	○	○
78	Reverse rotation prevention selection	4E	CE	0	○	○	○	○	○	○
79	Operation mode selection	4F	CF	0	○	○	○	○	○	○
80	Motor capacity	50	D0	0	×	○	○	○	○	○
81	Number of motor poles	51	D1	0	○	○	○	○	○	○
82	Motor excitation current	52	D2	0	○	○	×	○	×	○
83	Rated motor voltage	53	D3	0	×	○	○	○	○	○
84	Rated motor frequency	54	D4	0	×	○	○	○	○	○
89	Speed control gain (Advanced magnetic flux vector)	59	D9	0	×	○	×	○	×	○
90	Motor constant (R1)	5A	DA	0	×	○	○	○	×	○
91	Motor constant (R2)	5B	DB	0	×	○	×	○	×	○
92	Motor constant (L1)/d-axis inductance (Ld)	5C	DC	0	×	○	○	○	×	○
93	Motor constant (L2)/q-axis inductance (Lq)	5D	DD	0	×	○	○	○	×	○
94	Motor constant (X)	5E	DE	0	×	○	×	○	×	○
96	Auto tuning setting/status	60	E0	0	×	○	○	○	×	○
117	RS-485 communication station number	11	91	1	○	○	○	○	○ ^{*4}	○ ^{*4}

Pr.	Name	Instruction code ^{*1}			Control method ^{*2}			Parameter		
		Read	Write	Extended	V/F	Magnetic flux	PM	Copy ^{*3}	Clear ^{*3}	All clear ^{*3}
118	RS-485 communication speed	12	92	1	○	○	○	○	○ ^{*4}	○ ^{*4}
119	RS-485 communication stop bit length / data length	13	93	1	○	○	○	○	○ ^{*4}	○ ^{*4}
120	RS-485 communication parity check	14	94	1	○	○	○	○	○ ^{*4}	○ ^{*4}
121	RS-485 communication retry count	15	95	1	○	○	○	○	○ ^{*4}	○ ^{*4}
122	RS-485 communication check time interval	16	96	1	○	○	○	○	○ ^{*4}	○ ^{*4}
123	RS-485 communication waiting time setting	17	97	1	○	○	○	○	○ ^{*4}	○ ^{*4}
124	RS-485 communication CR/LF selection	18	98	1	○	○	○	○	○ ^{*4}	○ ^{*4}
125	Terminal 2 frequency setting gain frequency	19	99	1	○	○	○	○	×	○
126	Terminal 4 frequency setting gain frequency	1A	9A	1	○	○	○	○	×	○
127	PID control automatic switchover frequency	1B	9B	1	○	○	○	○	○	○
128	PID action selection	1C	9C	1	○	○	○	○	○	○
129	PID proportional band	1D	9D	1	○	○	○	○	○	○
130	PID integral time	1E	9E	1	○	○	○	○	○	○
131	PID upper limit	1F	9F	1	○	○	○	○	○	○
132	PID lower limit	20	A0	1	○	○	○	○	○	○
133	PID action set point	21	A1	1	○	○	○	○	○	○
134	PID differential time	22	A2	1	○	○	○	○	○	○
136	MC switchover interlock time	24	A4	1	○	○	×	○	○	○
139	Automatic switchover frequency from inverter to bypass operation	27	A7	1	○	○	×	○	○	○
145	PU display language selection	2D	AD	1	○	○	○	○	×	×
150	Output current detection level	32	B2	1	○	○	○	○	○	○
151	Output current detection signal delay time	33	B3	1	○	○	○	○	○	○
152	Zero current detection level	34	B4	1	○	○	○	○	○	○
153	Zero current detection time	35	B5	1	○	○	○	○	○	○
154	Voltage reduction selection during stall prevention operation	36	B6	1	○	○	×	○	○	○
156	Stall prevention operation selection	38	B8	1	○	○	○	○	○	○
157	OL signal output timer	39	B9	1	○	○	○	○	○	○
158	AM terminal function selection	3A	BA	1	○	○	○	○	○	○
160	User group read selection	00	80	2	○	○	○	○	○	○
161	Frequency setting/key lock operation selection	01	81	2	○	○	○	○	×	○
162	Automatic restart after instantaneous power failure selection	02	82	2	○	○	○	○	○	○
165	Stall prevention operation level for restart	05	85	2	○	○	×	○	○	○
166	Output current detection signal retention time	06	86	2	○	○	○	○	○	○
167	Output current detection operation selection	07	87	2	○	○	○	○	○	○
168	Parameter for manufacturer setting. Do not set.									
169										
170	Watt-hour meter clear	0A	8A	2	○	○	○	○	×	○
171	Operation hour meter clear	0B	8B	2	○	○	○	×	×	×
172	User group registered display/batch clear	0C	8C	2	○	○	○	○	×	×
173	User group registration	0D	8D	2	○	○	○	×	×	×
174	User group clear	0E	8E	2	○	○	○	×	×	×
178	STF terminal function selection	12	92	2	○	○	○	○	×	○
179	STR terminal function selection	13	93	2	○	○	○	○	×	○
180	RL terminal function selection	14	94	2	○	○	○	○	×	○



Pr.	Name	Instruction code ^{*1}			Control method ^{*2}			Parameter		
		Read	Write	Extended	V/F	Magnetic flux	PM	Copy ^{*3}	Clear ^{*3}	All clear ^{*3}
181	RM terminal function selection	15	95	2	○	○	○	○	×	○
182	RH terminal function selection	16	96	2	○	○	○	○	×	○
185	NET X1 input selection	19	99	2	○	○	○	○	×	○
186	NET X2 input selection	1A	9A	2	○	○	○	○	×	○
187	NET X3 input selection	1B	9B	2	○	○	○	○	×	○
188	NET X4 input selection	1C	9C	2	○	○	○	○	×	○
189	NET X5 input selection	1D	9D	2	○	○	○	○	×	○
190	RUN terminal function selection	1E	9E	2	○	○	○	○	×	○
191	FU terminal function selection	1F	9F	2	○	○	○	○	×	○
192	ABC terminal function selection	20	A0	2	○	○	○	○	×	○
193	NET Y1 output selection	21	A1	2	○	○	○	○	×	○
194	NET Y2 output selection	22	A2	2	○	○	○	○	×	○
195	NET Y3 output selection	23	A3	2	○	○	○	○	×	○
196	NET Y4 output selection	24	A4	2	○	○	○	○	×	○
232	Multi-speed setting (speed 8)	28	A8	2	○	○	○	○	○	○
233	Multi-speed setting (speed 9)	29	A9	2	○	○	○	○	○	○
234	Multi-speed setting (speed 10)	2A	AA	2	○	○	○	○	○	○
235	Multi-speed setting (speed 11)	2B	AB	2	○	○	○	○	○	○
236	Multi-speed setting (speed 12)	2C	AC	2	○	○	○	○	○	○
237	Multi-speed setting (speed 13)	2D	AD	2	○	○	○	○	○	○
238	Multi-speed setting (speed 14)	2E	AE	2	○	○	○	○	○	○
239	Multi-speed setting (speed 15)	2F	AF	2	○	○	○	○	○	○
240	Soft-PWM operation selection	30	B0	2	○	○	○	○	○	○
241	Analog input display unit switchover	31	B1	2	○	○	○	○	○	○
244	Cooling fan operation selection	34	B4	2	○	○	○	○	○	○
245	Rated slip	35	B5	2	○	×	×	○	○	○
246	Slip compensation time constant	36	B6	2	○	×	×	○	○	○
247	Constant output range slip compensation selection	37	B7	2	○	×	×	○	○	○
249	Earth (ground) fault detection at start	39	B9	2	○	○	○	○	○	○
250	Stop selection	3A	BA	2	○	○	○	○	○	○
251	Output phase loss protection selection	3B	BB	2	○	○	○	○	○	○
255	Life alarm status display	3F	BF	2	○	○	○	×	×	×
256	Inrush current limit circuit life display	40	C0	2	○	○	○	×	×	×
257	Control circuit capacitor life display	41	C1	2	○	○	○	×	×	×
258	Main circuit capacitor life display	42	C2	2	○	○	○	×	×	×
259	Main circuit capacitor life measuring	43	C3	2	○	○	○	○	○	○
260	PWM frequency automatic switchover	44	C4	2	○	○	○	○	○	○
261	Power failure stop selection	45	C5	2	○	○	○	○	○	○
267	Terminal 4 input selection	4B	CB	2	○	○	○	○	×	○
268	Monitor decimal digits selection	4C	CC	2	○	○	○	○	○	○
269	Parameter for manufacturer setting. Do not set.									
289	Inverter output terminal filter	61	E1	2	○	○	○	○	×	○
291	Pulse train input selection	63	E3	2	○	○	○	○	×	○
295	Frequency change increment amount setting	67	E7	2	○	○	○	○	○	○
296	Password lock level	68	E8	2	○	○	○	○	×	○
297	Password lock/unlock	69	E9	2	○	○	○	○	○ ^{*5}	○
298	Frequency search gain	6A	EA	2	○	○	×	○	×	○
299	Rotation direction detection selection at restarting	6B	EB	2	○	○	×	○	○	○
338	Communication operation command source	26	A6	3	○	○	○	○	○ ^{*4}	○ ^{*4}
339	Communication speed command source	27	A7	3	○	○	○	○	○ ^{*4}	○ ^{*4}
340	Communication startup mode selection	28	A8	3	○	○	○	○	○ ^{*4}	○ ^{*4}

Pr.	Name	Instruction code ^{*1}			Control method ^{*2}			Parameter		
		Read	Write	Extended				Copy ^{*3}	Clear ^{*3}	All clear ^{*3}
342	Communication EEPROM write selection	2A	AA	3	○	○	○	○	○	○
343	Communication error count	2B	AB	3	○	○	○	×	×	×
374	Overspeed detection level	4A	CA	3	×	×	○	○	○	○
384	Input pulse division scaling factor	54	D4	3	○	○	○	○	○	○
385	Frequency for zero input pulse	55	D5	3	○	○	○	○	○	○
386	Frequency for maximum input pulse	56	D6	3	○	○	○	○	○	○
450	Second applied motor	32	B2	4	○	○	○	○	○	○
495	Remote output selection	5F	DF	4	○	○	○	○	○	○
496	Remote output data 1	60	E0	4	○	○	○	×	×	×
502	Stop mode selection at communication error	02	82	5	○	○	○	○	○	○
503	Maintenance timer	03	83	5	○	○	○	×	×	×
504	Maintenance timer warning output set time	04	84	5	○	○	○	○	×	○
505	Speed setting reference	05	85	5	○	○	○	○	○	○
506	Display estimated main circuit capacitor residual life	06	86	5	○	○	○	×	×	×
507	Display/reset ABC relay contact life	07	87	5	○	○	○	×	×	×
509	Display power cycle life	09	89	5	○	○	○	×	×	×
514	Emergency drive dedicated retry waiting time	0E	8E	5	○	○	○	○	×	○
515	Emergency drive dedicated retry count	0F	8F	5	○	○	○	○	×	○
523	Emergency drive mode selection	17	97	5	○	○	○	○	×	○
524	Emergency drive running speed	18	98	5	○	○	○	○	×	○
532	Vibration suppression mode selection	20	A0	5	×	×	○	○	○	○
533	Vibration suppression response adjustment	21	A1	5	×	×	○	○	○	○
534	Maximum vibration suppression frequency	22	A2	5	×	×	○	○	○	○
535	Minimum vibration suppression frequency	23	A3	5	×	×	○	○	○	○
547	USB communication station number	2F	AF	5	○	○	○	○	○ ^{*4}	○ ^{*4}
548	USB communication check time interval	30	B0	5	○	○	○	○	○ ^{*4}	○ ^{*4}
549	Protocol selection	31	B1	5	○	○	○	○	○ ^{*4}	○ ^{*4}
551	PU mode operation command source selection	33	B3	5	○	○	○	○	○ ^{*4}	○ ^{*4}
552	Frequency jump range	34	B4	5	○	○	○	○	○	○
553	PID deviation limit	35	B5	5	○	○	○	○	○	○
554	PID signal operation selection	36	B6	5	○	○	○	○	○	○
555	Current average time	37	B7	5	○	○	○	○	○	○
556	Data output mask time	38	B8	5	○	○	○	○	○	○
557	Current average value monitor signal output reference current	39	B9	5	○	○	○	○	○	○
561	PTC thermistor protection level	3D	BD	5	○	○	○	○	×	○
563	Energization time carrying-over times	3F	BF	5	○	○	○	×	×	×
564	Operating time carrying-over times	40	C0	5	○	○	○	×	×	×
570	Multiple rating setting 	46	C6	5	○	○	○	○	×	×
571	Holding time at a start	47	C7	5	○	○	×	○	○	○
575	Output interruption detection time	4B	CB	5	○	○	○	○	○	○
576	Output interruption detection level	4C	CC	5	○	○	○	○	○	○
577	Output interruption cancel level	4D	CD	5	○	○	○	○	○	○
592	Traverse function selection	5C	DC	5	○	○	○	○	○	○
593	Maximum amplitude amount	5D	DD	5	○	○	○	○	○	○

Pr.	Name	Instruction code ^{*1}			Control method ^{*2}			Parameter		
		Read	Write	Extended	V/F	Magnetic flux	PM	Copy ^{*3}	Clear ^{*3}	All clear ^{*3}
594	Amplitude compensation amount during deceleration	5E	DE	5	○	○	○	○	○	○
595	Amplitude compensation amount during acceleration	5F	DF	5	○	○	○	○	○	○
596	Amplitude acceleration time	60	E0	5	○	○	○	○	○	○
597	Amplitude deceleration time	61	E1	5	○	○	○	○	○	○
600	First free thermal reduction frequency 1	00	80	6	○	○	○	○	○	○
601	First free thermal reduction ratio 1	01	81	6	○	○	○	○	○	○
602	First free thermal reduction frequency 2	02	82	6	○	○	○	○	○	○
603	First free thermal reduction ratio 2	03	83	6	○	○	○	○	○	○
604	First free thermal reduction frequency 3	04	84	6	○	○	○	○	○	○
607	Motor permissible load level	07	87	6	○	○	○	○	○	○
608	Second motor permissible load level	08	88	6	○	○	○	○	○	○
609	PID set point/deviation input selection	09	89	6	○	○	○	○	○	○
610	PID measured value input selection	0A	8A	6	○	○	○	○	○	○
611	Acceleration time at a restart	0B	8B	6	○	○	○	○	○	○
631	Inverter output fault detection enable/disable selection	1F	9F	6	○	○	○	×	×	×
643	Voltage compensation amount setting	2B	AB	6	×	×	○	○	○	○
653	Speed smoothing control	35	B5	6	○	○	×	○	○	○
654	Speed smoothing cutoff frequency	36	B6	6	○	○	×	○	○	○
660	Increased magnetic excitation deceleration operation selection	3C	BC	6	○	○	×	○	○	○
661	Magnetic excitation increase rate	3D	BD	6	○	○	×	○	○	○
662	Increased magnetic excitation current level	3E	BE	6	○	○	×	○	○	○
663	Control circuit temperature signal output level	3F	BF	6	○	○	○	○	○	○
665	Regeneration avoidance frequency gain	41	C1	6	○	○	○	○	○	○
673	SF-PR slip amount adjustment operation selection	49	C9	6	○	×	×	○	○	○
674	SF-PR slip amount adjustment gain	4A	CA	6	○	×	×	○	○	○
692	Second free thermal reduction frequency 1	5C	DC	6	○	○	○	○	○	○
693	Second free thermal reduction ratio 1	5D	DD	6	○	○	○	○	○	○
694	Second free thermal reduction frequency 2	5E	DE	6	○	○	○	○	○	○
695	Second free thermal reduction ratio 2	5F	DF	6	○	○	○	○	○	○
696	Second free thermal reduction frequency 3	60	E0	6	○	○	○	○	○	○
699	Input terminal filter	63	E3	6	○	○	○	○	×	○
702	Maximum motor frequency	02	82	7	×	×	○	○	○	○
706	Motor induced voltage constant (phi f)	06	86	7	×	×	○	○	×	○
707	Motor inertia (integer)	07	87	7	×	×	○	○	○	○
711	Motor Ld decay ratio	0B	8B	7	×	×	○	○	×	○
712	Motor Lq decay ratio	0C	8C	7	×	×	○	○	×	○
717	Starting resistance tuning compensation coefficient	11	91	7	×	○	○	○	×	○
721	Starting magnetic pole position detection pulse width	15	95	7	×	×	○	○	×	○
724	Motor inertia (exponent)	18	98	7	×	×	○	○	○	○
725	Motor protection current level	19	99	7	×	×	○	○	○	○
759	PID unit selection	3B	BB	7	○	○	○	○	○	○
774	Operation panel monitor selection 1	4A	CA	7	○	○	○	○	○	○

Pr.	Name	Instruction code ^{*1}			Control method ^{*2}			Parameter		
		Read	Write	Extended				Copy ^{*3}	Clear ^{*3}	All clear ^{*3}
775	Operation panel monitor selection 2	4B	CB	7	○	○	○	○	○	○
776	Operation panel monitor selection 3	4C	CC	7	○	○	○	○	○	○
779	Operation frequency during communication error	4F	CF	7	○	○	○	○	○	○
791	Acceleration time in low-speed range	5B	DB	7	×	×	○	○	○	○
792	Deceleration time in low-speed range	5C	DC	7	×	×	○	○	○	○
795	DC injection brake operation current level	5F	DF	7	×	×	○	○	×	○
799	Pulse increment setting for output power	63	E3	7	○	○	○	○	○	○
800	Control method selection	00	80	8	○	○	○	○	○	○
810	Torque limit input method selection	0A	8A	8	×	×	○	○	○	○
811	Set resolution switchover	0B	8B	8	×	×	○	○	○	○
815	Torque limit level 2	0F	8F	8	×	×	○	○	○	○
820	Speed control P gain	14	94	8	×	×	○	○	○	○
821	Speed control integral time	15	95	8	×	×	○	○	○	○
824	Torque control P gain (current loop proportional gain)	18	98	8	×	×	○	○	○	○
825	Torque control integral time (current loop integral time)	19	99	8	×	×	○	○	○	○
859	Torque current/Rated PM motor current	3B	BB	8	×	○	○	○	×	○
865	Low speed detection	41	C1	8	○	○	○	○	○	○
866	Torque monitoring reference	42	C2	8	×	○	○	○	○	○
870	Speed detection hysteresis	46	C6	8	○	○	○	○	○	○
872	Input phase loss protection selection 	48	C8	8	○	○	○	○	○	○
874	OLT level setting	4A	CA	8	×	×	○	○	○	○
882	Regeneration avoidance operation selection	52	D2	8	○	○	○	○	○	○
883	Regeneration avoidance operation level	53	D3	8	○	○	○	○	○	○
885	Regeneration avoidance compensation frequency limit value	55	D5	8	○	○	○	○	○	○
886	Regeneration avoidance voltage gain	56	D6	8	○	○	○	○	○	○
888	Free parameter 1	58	D8	8	○	○	○	○	×	×
889	Free parameter 2	59	D9	8	○	○	○	○	×	×
890	Internal storage device status indication	5A	DA	8	○	○	○	×	×	×
891	Cumulative power monitor digit shifted times	5B	DB	8	○	○	○	○	○	○
892	Load factor	5C	DC	8	○	○	○	○	○	○
893	Energy saving monitor reference (motor capacity)	5D	DD	8	○	○	○	○	○	○
894	Control selection during commercial power-supply operation	5E	DE	8	○	○	○	○	○	○
895	Power saving rate reference value	5F	DF	8	○	○	○	○	○	○
896	Power unit cost / CO ₂ emission coefficient	60	E0	8	○	○	○	○	○	○
897	Energy saving monitor average time	61	E1	8	○	○	○	○	○	○
898	Energy saving cumulative monitor clear	62	E2	8	○	○	○	○	×	○
899	Operation time rate (estimated value)	63	E3	8	○	○	○	○	○	○
C1 (901)	AM terminal calibration	5D	DD	1	○	○	○	○	×	○
C2 (902)	Terminal 2 frequency setting bias frequency	5E	DE	1	○	○	○	○	×	○

Pr.	Name	Instruction code ^{*1}			Control method ^{*2}			Parameter		
		Read	Write	Extended	V/F	Magnetic flux	PM	Copy ^{*3}	Clear ^{*3}	All clear ^{*3}
C3 (902)	Terminal 2 frequency setting bias	5E	DE	1	○	○	○	○	×	○
125 (903)	Terminal 2 frequency setting gain frequency	5F	DF	1	○	○	○	○	×	○
C4 (903)	Terminal 2 frequency setting gain	5F	DF	1	○	○	○	○	×	○
C5 (904)	Terminal 4 frequency setting bias frequency	60	E0	1	○	○	○	○	×	○
C6 (904)	Terminal 4 frequency setting bias	60	E0	1	○	○	○	○	×	○
126 (905)	Terminal 4 frequency setting gain frequency	61	E1	1	○	○	○	○	×	○
C7 (905)	Terminal 4 frequency setting gain	61	E1	1	○	○	○	○	×	○
C42 (934)	PID display bias coefficient	22	A2	9	○	○	○	○	×	○
C43 (934)	PID display bias analog value	22	A2	9	○	○	○	○	×	○
C44 (935)	PID display gain coefficient	23	A3	9	○	○	○	○	×	○
C45 (935)	PID display gain analog value	23	A3	9	○	○	○	○	×	○
990	PU buzzer control	5A	DA	9	○	○	○	○	○	○
991	PU contrast adjustment	5B	DB	9	○	○	○	○	×	○
992	Operation panel setting dial push monitor selection	5C	DC	9	○	○	○	○	○	○
997	Fault initiation	61	E1	9	○	○	○	×	○	○
998	PM parameter initialization	62	E2	9	○	○	○	○	○	○
999	Automatic parameter setting	63	E3	9	○	○	○	×	×	○
1002	Lq tuning target current adjustment coefficient	02	82	A	×	×	○	○	○	○
1006	Clock (year)	06	86	A	○	○	○	×	×	×
1007	Clock (month, day)	07	87	A	○	○	○	×	×	×
1008	Clock (hour, minute)	08	88	A	○	○	○	×	×	×
1013	Running speed after recovery from emergency drive undervoltage	0D	8D	A	○	○	○	○	×	○
1015	Integral stop selection at limited frequency	0F	8F	A	○	○	○	○	○	○
1016	PTC thermistor protection detection time	10	90	A	○	○	○	○	×	○
1020	Trace operation selection	14	94	A	○	○	○	○	○	○
1022	Sampling cycle	16	96	A	○	○	○	○	○	○
1023	Number of analog channels	17	97	A	○	○	○	○	○	○
1024	Sampling auto start	18	98	A	○	○	○	○	○	○
1025	Trigger mode selection	19	99	A	○	○	○	○	○	○
1026	Number of sampling before trigger	1A	9A	A	○	○	○	○	○	○
1027	Analog source selection (1ch)	1B	9B	A	○	○	○	○	○	○
1028	Analog source selection (2ch)	1C	9C	A	○	○	○	○	○	○
1029	Analog source selection (3ch)	1D	9D	A	○	○	○	○	○	○
1030	Analog source selection (4ch)	1E	9E	A	○	○	○	○	○	○
1031	Analog source selection (5ch)	1F	9F	A	○	○	○	○	○	○
1032	Analog source selection (6ch)	20	A0	A	○	○	○	○	○	○
1033	Analog source selection (7ch)	21	A1	A	○	○	○	○	○	○
1034	Analog source selection (8ch)	22	A2	A	○	○	○	○	○	○
1035	Analog trigger channel	23	A3	A	○	○	○	○	○	○
1036	Analog trigger operation selection	24	A4	A	○	○	○	○	○	○
1037	Analog trigger level	25	A5	A	○	○	○	○	○	○
1038	Digital source selection (1ch)	26	A6	A	○	○	○	○	○	○
1039	Digital source selection (2ch)	27	A7	A	○	○	○	○	○	○
1040	Digital source selection (3ch)	28	A8	A	○	○	○	○	○	○

Pr.	Name	Instruction code ^{*1}			Control method ^{*2}			Parameter		
		Read	Write	Extended				Copy ^{*3}	Clear ^{*3}	All clear ^{*3}
1041	Digital source selection (4ch)	29	A9	A	○	○	○	○	○	○
1042	Digital source selection (5ch)	2A	AA	A	○	○	○	○	○	○
1043	Digital source selection (6ch)	2B	AB	A	○	○	○	○	○	○
1044	Digital source selection (7ch)	2C	AC	A	○	○	○	○	○	○
1045	Digital source selection (8ch)	2D	AD	A	○	○	○	○	○	○
1046	Digital trigger channel	2E	AE	A	○	○	○	○	○	○
1047	Digital trigger operation selection	2F	AF	A	○	○	○	○	○	○
1048	Display-off waiting time	30	B0	A	○	○	○	○	○	○
1106	Torque monitor filter	06	86	B	○	○	○	○	○	○
1107	Running speed monitor filter	07	87	B	○	○	○	○	○	○
1108	Excitation current monitor filter	08	88	B	○	○	○	○	○	○
1200	AM output offset calibration	00	80	C	○	○	○	○	×	○
1412	Motor induced voltage constant (phi f) exponent	0C	8C	E	×	×	○	○	×	○
1480	Load characteristics measurement mode	50	D0	E	○	○	○	○	○	○
1481	Load characteristics load reference 1	51	D1	E	○	○	○	○	○	○
1482	Load characteristics load reference 2	52	D2	E	○	○	○	○	○	○
1483	Load characteristics load reference 3	53	D3	E	○	○	○	○	○	○
1484	Load characteristics load reference 4	54	D4	E	○	○	○	○	○	○
1485	Load characteristics load reference 5	55	D5	E	○	○	○	○	○	○
1486	Load characteristics maximum frequency	56	D6	E	○	○	○	○	○	○
1487	Load characteristics minimum frequency	57	D7	E	○	○	○	○	○	○
1488	Upper limit warning detection width	58	D8	E	○	○	○	○	○	○
1489	Lower limit warning detection width	59	D9	E	○	○	○	○	○	○
1490	Upper limit fault detection width	5A	DA	E	○	○	○	○	○	○
1491	Lower limit fault detection width	5B	DB	E	○	○	○	○	○	○
1492	Load status detection signal delay time / load reference measurement waiting time	5C	DC	E	○	○	○	○	○	○
1499	Parameter for manufacturer setting. Do not set.									

Warranty

When using this product, make sure to understand the warranty described below.

1. Warranty period and coverage

We will repair any failure or defect (hereinafter referred to as "failure") in our FA equipment (hereinafter referred to as the "Product") arisen during warranty period at no charge due to causes for which we are responsible through the distributor from which you purchased the Product or our service provider. However, we will charge the actual cost of dispatching our engineer for an on-site repair work on request by customer in Japan or overseas countries. We are not responsible for any on-site readjustment and/or trial run that may be required after a defective unit are repaired or replaced.

[Term]

The term of warranty for Product is twelve months after your purchase or delivery of the Product to a place designated by you or eighteen months from the date of manufacture whichever comes first ("Warranty Period"). Warranty period for repaired Product cannot exceed beyond the original warranty period before any repair work.

[Limitations]

- (1) You are requested to conduct an initial failure diagnosis by yourself, as a general rule. It can also be carried out by us or our service company upon your request and the actual cost will be charged.
However, it will not be charged if we are responsible for the cause of the failure.
- (2) This limited warranty applies only when the condition, method, environment, etc. of use are in compliance with the terms and conditions and instructions that are set forth in the instruction manual and user manual for the Product and the caution label affixed to the Product.
- (3) Even during the term of warranty, the repair cost will be charged on you in the following cases;
 - a failure caused by your improper storing or handling, carelessness or negligence, etc., and a failure caused by your hardware or software problem
 - a failure caused by any alteration, etc. to the Product made on your side without our approval
 - a failure which may be regarded as avoidable, if your equipment in which the Product is incorporated is equipped with a safety device required by applicable laws and has any function or structure considered to be indispensable according to a common sense in the industry
 - a failure which may be regarded as avoidable if consumable parts designated in the instruction manual, etc. are duly maintained and replaced
 - any replacement of consumable parts (condenser, cooling fan, etc.)
 - a failure caused by external factors such as inevitable accidents, including without limitation fire and abnormal fluctuation of voltage, and acts of God, including without limitation earthquake, lightning and natural disasters
 - a failure caused by using the emergency drive function
 - a failure generated by an unforeseeable cause with a scientific technology that was not available at the time of the shipment of the Product from our company
 - any other failures which we are not responsible for or which you acknowledge we are not responsible for

2. Term of warranty after the stop of production

- (1) We may accept the repair at charge for another seven (7) years after the production of the product is discontinued. The announcement of the stop of production for each model can be seen in our Sales and Service, etc.
- (2) Please note that the Product (including its spare parts) cannot be ordered after its stop of production.

3. Service in overseas

Our regional FA Center in overseas countries will accept the repair work of the Product; however, the terms and conditions of the repair work may differ depending on each FA Center. Please ask your local FA center for details.

4. Exclusion of loss in opportunity and secondary loss from warranty liability

Regardless of the gratis warranty term, Mitsubishi Electric shall not be liable for compensation to:

- (1) Damages caused by any cause found not to be the responsibility of Mitsubishi Electric.
- (2) Loss in opportunity, lost profits incurred to the user by Failures of Mitsubishi Electric products.
- (3) Special damages and secondary damages whether foreseeable or not, compensation for accidents, and compensation for damages to products other than Mitsubishi Electric products.
- (4) Replacement by the user, maintenance of on-site equipment, start-up test run and other tasks.

5. Change of Product specifications

Specifications listed in our catalogs, manuals or technical documents may be changed without notice.

6. Application and use of the Product

- (1) For the use of our product, its applications should be those that may not result in a serious damage even if any failure or malfunction occurs in product, and a backup or fail-safe function should operate on an external system to product when any failure or malfunction occurs.
- (2) Our product is designed and manufactured as a general purpose product for use at general industries.
Therefore, applications substantially influential on the public interest for such as atomic power plants and other power plants of electric power companies, and also which require a special quality assurance system, including applications for railway companies and government or public offices are not recommended, and we assume no responsibility for any failure caused by these applications when used.

In addition, applications which may be substantially influential to human lives or properties for such as airlines, medical treatments, railway service, incineration and fuel systems, man-operated material handling equipment, entertainment machines, safety machines, etc. are not recommended, and we assume no responsibility for any failure caused by these applications when used. We will review the acceptability of the abovementioned applications, if you agree not to require a specific quality for a specific application. Please contact us for consultation.

Model	FR-D800 TORISETSU KINOU EIBUN
Model code	1AJ081

MITSUBISHI ELECTRIC CORPORATION

HEAD OFFICE: TOKYO BUILDING 2-7-3, MARUNOUCHI, CHIYODA-KU, TOKYO 100-8310, JAPAN