

INVERTER

FR-D800

**Instruction Manual (Connection)
(Standard model)**

Compact & easy-to-use inverter

FR-D820-0.1K-008 to 15K-580

FR-D840-0.4K-012 to 15K-295

FR-D820S-0.1K-008 to 2.2K-100

FR-D810W-0.1K-008 to 0.75K-042

Safety Instructions	4
Chapter 1 Introduction	11
1.1 Product checking	12
1.2 Component names	14
1.3 Operation steps	15
1.4 Related manuals	16
Chapter 2 Installation and Wiring	17
2.1 Peripheral devices	17
2.1.1 Inverter and peripheral devices	17
2.1.2 Peripheral devices	19
2.2 Opening/closing of the front cover and removal/reinstallation of the combed-shaped wiring cover	22
2.3 Installation of the inverter and enclosure design	35
2.3.1 Inverter installation environment	35
2.3.2 Amount of heat generated by the inverter	37
2.3.3 Output current reduction when the surrounding air temperature is between 50°C and 60°C for ND rating and between 40°C and 60°C for SLD rating	39
2.3.4 Standby power consumption by the inverter	42
2.3.5 Cooling system types for inverter enclosure	43
2.3.6 Inverter installation	44
2.4 Terminal connection diagrams	46
2.5 Main circuit terminals	50
2.5.1 Details on the main circuit terminals	50
2.5.2 Main circuit terminal layout and wiring to power supply and motor	50
2.5.3 Applicable cables and wiring length	53
2.5.4 Earthing (grounding) precautions	58
2.6 Control circuit	59
2.6.1 Details on the control circuit terminals	59
2.6.2 Control logic (sink/source) change	62
2.6.3 Wiring of control circuit	64
2.6.4 Safety stop function	68
2.7 Communication connectors and terminals	70
2.7.1 PU connector	70
2.7.2 Wiring and configuration of RS-485 terminals	74
2.7.3 USB connector	77

2.8	Connection of stand-alone option units	78
2.8.1	Connection of the brake resistor (FR-D820-0.4K-025 or higher, FR-D840-0.4K-012 or higher, FR-D820S-0.4K-025 or higher, and FR-D810W-0.4K-025 or higher)	78
2.8.2	Connection of the brake unit (FR-BU2(-H))	82
2.8.3	Connection of the high power factor converter (FR-HC2)	84
2.8.4	Connection of the multifunction regeneration converter (FR-XC)	85
2.8.5	Connection of the AC reactor (FR-HAL)	86
2.8.6	Connection of the DC reactor (FR-HEL)	87

Chapter 3 Precautions for Use of the Inverter 88

3.1	Electro-magnetic interference (EMI) and leakage currents	88
3.1.1	Leakage currents and countermeasures	88
3.1.2	Techniques and measures for electromagnetic compatibility (EMC)	90
3.2	Power supply harmonics	93
3.2.1	Power supply harmonics	93
3.2.2	Harmonic suppression guidelines in Japan	93
3.3	Installation of a reactor	97
3.4	Power shutdown and magnetic contactor (MC)	98
3.5	Countermeasures against deterioration of the 400 V class motor insulation	100
3.6	Checklist before starting operation	101
3.7	Failsafe system which uses the inverter	104

Chapter 4 Specifications 107

4.1	Inverter rating	107
4.2	Motor rating	111
4.2.1	PM motor EM-A	111
4.3	Common specifications	115
4.4	Outline dimension drawings	117
4.4.1	Inverter outline dimension drawings	117
4.4.2	Dedicated motor outline dimension drawings	122

Chapter 5 Appendix 128

5.1 Instructions for EAC 128

5.2 Compliance with the UK certification scheme 128

5.3 Restricted Use of Hazardous Substances in Electronic and Electrical Products. 129

5.4 Referenced Standard
(Requirement of Chinese standardized law) 129

Warranty 131

Revisions 132

Safety Instructions

Thank you for choosing Mitsubishi Electric inverter.

This Instruction Manual provides detailed instructions for advanced settings of the FR-D800 series inverters.

Incorrect handling might cause an unexpected fault. Before using this product, read this Instruction Manual and the document enclosed with the product carefully to ensure proper use.

Do not attempt to install, operate, maintain or inspect this product until you have read the Instruction Manuals and supplementary documents carefully. Do not use this product until you have a full knowledge of this product mechanism, safety information and instructions.

Installation, operation, maintenance and inspection must be performed by qualified personnel. Here, qualified personnel means a person who meets all the following conditions:

- A person who possesses a certification in regard with electric appliance handling, or a person who took a proper engineering training. Such training may be available at your local Mitsubishi Electric office.
- A person who can access operating manuals for the protective devices (for example, light curtain) connected to the safety control system, or a person who has read these manuals thoroughly and familiarized themselves with the protective devices.

In this Instruction Manual, the safety instruction levels are classified into "WARNING" and "CAUTION".

⚠ WARNING Incorrect handling may cause hazardous conditions, resulting in death or severe injury.

⚠ CAUTION Incorrect handling may cause hazardous conditions, resulting in medium or slight injury, or may cause only material damage.

Note that even the **⚠ CAUTION** level may lead to a serious consequence depending on conditions. Be sure to follow the instructions of both levels as they are critical to personnel safety.

Electric shock prevention

⚠ WARNING

- Do not remove the front cover or the wiring cover while the power of this product is ON, and do not run this product with the front cover or the wiring cover removed as the exposed high voltage terminals or the charging part of the circuitry can be touched. Otherwise you may get an electric shock.
- Even if power is OFF, do not open the front cover except for wiring or periodic inspection as the inside of this product is charged. Otherwise you may get an electric shock.
- Before wiring or inspection, check that the LED display of the operation panel is OFF. Any person who is involved in wiring or inspection shall wait for 10 minutes or longer after the power supply has been cut off, and check that there are no residual voltage using a digital multimeter or the like. The capacitor is charged with high voltage for some time after power OFF, and it is dangerous.
- This product must be earthed (grounded). Earthing (grounding) must conform to the requirements of national and local safety regulations and electrical code (NEC section 250, IEC 61140 class 1 and other applicable standards). A neutral-point earthed (grounded) power supply must be used for 400 V class of this product to be compliant with EN standard.
- Any person who is involved in wiring or inspection of this product shall be fully competent to do the work.
- This product body must be installed before wiring. Otherwise you may get an electric shock or be injured.
- Do not touch the setting dial or keys with wet hands. Doing so may cause an electric shock.
- Do not subject the cables to scratches, excessive stress, heavy loads or pinching. Doing so may cause an electric shock.
- Do not change the cooling fan while power is ON as it is dangerous.
- Do not touch the printed circuit board or handle the cables with wet hands. Doing so may cause an electric shock.
- Never touch the motor terminals, etc. right after powering OFF as the DC voltage is applied to the motor for 1 second at powering OFF if the main circuit capacitor capacity is measured. Doing so may cause an electric shock.

WARNING

- Before wiring or inspection for a PM motor, confirm that the PM motor is stopped as a PM motor is a synchronous motor with high-performance magnets embedded inside and high-voltage is generated at the motor terminals while the motor is running even after the power of this product is turned OFF. In an application, such as fan and blower, that the motor may be driven by the load, connect a low-voltage manual contactor at the output side of this product and keep it open during wiring and inspection of this product. Otherwise you may get an electric shock.

Fire prevention

CAUTION

- Do not apply voltages to the terminals other than those specified in Instruction Manual. Doing so may cause a fire.
- This product must be installed on a nonflammable wall without holes in it so that its components cannot be touched from behind. Installing it on or near flammable material may cause a fire.
- If this product becomes faulty, the product power must be switched OFF. A continuous flow of large current may cause a fire.
- When using a brake resistor, a sequence that will turn OFF power when a fault signal is output must be configured. Otherwise the brake resistor may excessively overheat due to damage of the brake transistor and such, causing a fire.
- Do not connect a resistor directly to the DC terminals P/+ and N/-. Doing so may cause a fire.
- Across terminals P/+ and PR, connect only an external brake resistor.
- Be sure to perform daily and periodic inspections as specified in the Instruction Manual (Maintenance). There is a possibility of explosion, damage, or fire if this product is used without inspection.

Injury prevention

CAUTION

- The voltage applied to each terminal must be as specified in the Instruction Manual. Otherwise an explosion or damage may occur.
- The cables must be connected to the correct terminals. Otherwise an explosion or damage may occur.
- The polarity (+ and -) must be correct. Otherwise an explosion or damage may occur.
- While power is ON or for some time after power-OFF, do not touch this product as it will be extremely hot. Doing so may cause burns.

Additional instructions

The following instructions must be also followed. If the product is handled incorrectly, it may cause unexpected fault, an injury, or an electric shock.

CAUTION

Transportation and installation

- To prevent injury, wear cut-resistant gloves when opening packaging with sharp tools.
- Use proper lifting techniques or a trolley when carrying products. Failure to do so may lead to injuries.
- Do not stand or place any heavy object on this product.
- Do not stack the boxes containing this product higher than the number recommended.
- When carrying this product, do not hold it by the front cover or the setting dial. It may fall or break.
- During installation, caution must be taken not to drop this product as doing so may cause injuries.
- The product must be installed on a surface that withstands the weight of the product.
- Do not install the product on a hot surface.
- Ensure the mounting orientation of this product is correct.
- Ensure this product is mounted securely with screws in its enclosure.
- Do not install or operate this product if it is damaged or has parts missing.
- Foreign conductive objects must be prevented from entering this product. That includes screws and metal fragments or other flammable substance such as oil.
- As this product is a precision instrument, do not drop or subject it to impact.
- The range of surrounding air temperature of the inverter is -20°C to $+60^{\circ}\text{C}$ (non-freezing). (ND rating: The rated current must be reduced at a temperature above 50°C . SLD rating: The rated current must be reduced at a temperature above 40°C .) Otherwise this product may be damaged.
- The ambient humidity must be 90% RH or less (non-condensing) for models without circuit board coating and 95% RH or less (non-condensing) for models with circuit board coating. Otherwise this product may be damaged.
- The temporary storage temperature (applicable to a short limited time such as a transportation time) must be between -40°C and $+70^{\circ}\text{C}$. Otherwise this product may be damaged.
- This product must be used indoors (without corrosive gas, flammable gas, oil mist, dust and dirt). Otherwise this product may be damaged.
- This product must be used at an altitude above 3000 m. Vibration should not exceed 5.9 m/s^2 at 10 to 55 Hz in X, Y, and Z directions. Otherwise this product may be damaged. (Refer to [page 35](#) for details.)
- If halogens (including fluorine, chlorine, bromine, and iodine) contained in fumigants for wood packages enter this product, the product may be damaged. Prevent the entry of fumigant residuals or use an alternative method such as heat disinfection. Note that sterilization or disinfection of wood packages should be performed before packing the product.

Wiring

- Do not install a power factor correction capacitor, surge absorber, or radio noise filter on the output side of this product. These devices may overheat or burn out.
- The output terminals (terminals U, V, and W) must be connected to a motor correctly. Otherwise the motor will rotate inversely.
- Even with the power OFF, high voltage is still applied to the terminals U, V and W while the PM motor is running. Ensure the PM motor has stopped before carrying out any wiring. Otherwise you may get an electric shock.
- Never connect a PM motor to a commercial power supply. Connecting a commercial power supply to the input terminals (U, V, W) of a PM motor will burn it out. The PM motor must be applied a power from the inverter with the output terminals (U, V, W).

Test operation

- Before starting the operation, confirm or adjust the parameter settings. Failure to do so may cause some machines to make unexpected motions.

WARNING

Usage

- Stay away from the equipment after using the retry function in this product as the equipment will restart suddenly after the output shutoff of this product.
- Access to the motor is allowed only after it is fully confirmed that the motor does not start running.
- Depending on the function settings of this product, the product does not stop its output even when the STOP/RESET key on the operation panel is pressed. To prepare for it, provide a separate circuit and switch (to turn OFF the power of this product, or apply a mechanical brake, etc.) for an emergency stop.
- Be sure to turn OFF the start (STF/STR) signal before clearing the fault as this product will restart the motor suddenly after a fault is cleared.
- Do not use a PM motor for an application that the motor may be driven by the load and run at a speed higher than the maximum motor speed.
- Use only a three-phase induction motor or PM motor as a load on this product. Connection of any other electrical equipment to the output of this product may damage the equipment.
- Do not modify this product.
- Do not remove any part which is not instructed to be removed in the Instruction Manuals. Doing so may lead to a failure or damage of this product.

CAUTION

Usage

- When installing the MC on the output side of the inverter, turn it ON/OFF while both the inverter and motor are at a stop.
- The electronic thermal O/L relay function may not be enough for protection of a motor from overheating. It is recommended to install an external thermal relay or a PTC thermistor for overheat protection.
- Do not repeatedly start or stop this product with a magnetic contactor on its input side. Doing so may shorten the life of this product.
- Use a noise filter or other means to minimize electromagnetic interference with other electronic equipment used nearby this product.
- Appropriate precautions must be taken to suppress harmonics. Otherwise harmonics in power systems generated from this product may heat/damage a power factor correction capacitor or a generator.
- To drive a 400 V class motor with this product, use an insulation-enhanced motor, or take measures to suppress surge voltage. Otherwise surge voltage, which is attributed to the length and thickness of wire, may occur at the motor terminals, causing the motor insulation to deteriorate.
- When a motor is driven by the inverter, axial voltage is generated on the motor shaft, which may cause electrical corrosion of the bearing. Take measures such as decreasing the carrier frequency.
- As all parameters return to their initial values after Parameter clear or All parameter clear is performed, the parameters must be set again as required before the operation is started.
- This product can be easily set for high-speed operation. Therefore, consider all things related to the operation such as the performance of a motor and equipment in a system before the setting change.
- This product's brake function cannot be used as a mechanical brake. Use a separate device instead.
- When performing an inverter operation with frequent starts/stops, rise/fall in the temperature of the transistor element of the inverter will repeat due to a repeated flow of large current, shortening the life.
- Perform an inspection and test operation of this product if it has been stored for a long period of time.
- To avoid damage to this product due to static electricity, static electricity in your body must be discharged before you touch this product.
- Only one PM motor can be connected to a single unit of this product.
- A PM motor must be used under PM sensorless vector control. Do not use a synchronous motor, induction motor, or synchronous induction motor.
- Do not connect a PM motor to this product with it set to the induction motor control setting (initial setting). Do not connect an induction motor to this product with it set to the PM sensorless vector control setting. Doing so will cause failure.
- As a process of starting a PM motor, turn ON the power of this product first, and then close the contactor on the output side of this product.
- To maintain the security (confidentiality, integrity, and availability) of the inverter and the system against unauthorized access, DoS^{*1} attacks, computer viruses, and other cyberattacks from external devices via network, take appropriate measures such as firewalls, virtual private networks (VPNs), and antivirus solutions. We shall have no responsibility or liability for any problems involving inverter trouble and system trouble by DoS attacks, unauthorized access, computer viruses, and other cyberattacks. (Refer to the FA System Security Guideline -Separate Volume [FREQROL]-.)
- Depending on the network environment, the inverter may not operate as intended due to delays or disconnection in communication. Carefully consider what type of environment the inverter will be used in and any safety issues related to its use.
- When the emergency drive function is enabled, the operation is continued or the retry operation (automatic reset and restart) is repeated even if a fault occurs, which may damage or burn this product and the motor. Before restarting the normal operation after the operation using the emergency drive function, make sure that this product and the motor have no fault.

*1 DoS: A denial-of-service (DoS) attack disrupts services by overloading systems or exploiting vulnerabilities, resulting in a denial-of-service (DoS) state.

CAUTION

Emergency stop

- A safety backup such as an emergency brake must be provided for devices or equipment in a system to prevent hazardous conditions in case of failure of this product or an external device controlling this product.
- If the breaker installed on the input side of this product trips, check for wiring faults (such as short circuits) and damage to internal parts of this product. Identify and remove the cause of the trip before resetting the tripped breaker (or before applying the power to this product again).
- When any protective function is activated, take an appropriate corrective action before resetting this product to resume the operation.

Maintenance, inspection and parts replacement

- Do not carry out a megger (insulation resistance) test on the control circuit of this product. Doing so will cause failure.

Disposal

- This product must be treated as industrial waste.

CAUTION

- We shall not be liable for the compliance or non-compliance with any local, national, or international codes or regulations for the installation of this product.
- Installation not compliant with applicable codes or directives may cause physical injury or damage to property.

General instruction

- For clarity, illustrations in this Instruction Manual may be drawn with covers or safety guards removed. Ensure all covers and safety guards are properly installed prior to starting operation. For details on the PM motor, refer to the Instruction Manual of the PM motor.

Application of caution labels

Caution labels are used to ensure safety during use of Mitsubishi Electric inverters.

Apply the following labels to the inverter if the "retry function" and/or "automatic restart after instantaneous power failure" have been enabled.

For the retry function

CAUTION
(Retry Function Has Been Selected)

Stay away from the motor and machine. They will start suddenly (after given time has elapsed) when alarm occurs.

For automatic restart after instantaneous power failure

CAUTION
(Automatic Restart after Instantaneous Power Failure Has Been Selected)

Stay away from the motor and machine. They will start suddenly (after reset time has elapsed) when instantaneous power failure occurs.

Application of motor control labels

Apply the following labels to the inverter to avoid connecting motors not intended for a particular motor control setting.

Induction motor setting

The inverter is set for the induction motor control.
PM LED is OFF during induction motor control.
Do not drive a PM motor.

The image shows the control panel of a Mitsubishi Electric inverter. The digital display shows '0000'. The 'PM' indicator LED is not illuminated. The control panel includes buttons for 'HAND STOP', 'MODE', 'SET', 'RUN', and 'STOP/RESET', along with a rotary selector switch.

PM motor control setting

The inverter is set for the PM motor control.
PM LED is ON during PM motor control.
Do not drive an induction motor.

The image shows the control panel of a Mitsubishi Electric inverter. The digital display shows '0000'. The 'PM' indicator LED is illuminated. The control panel includes buttons for 'HAND STOP', 'MODE', 'SET', 'RUN', and 'STOP/RESET', along with a rotary selector switch.

1 Introduction

The contents described in this chapter must be read before using this product.
Always read the instructions before use.

◆ Abbreviations

Item	Description
Operation panel	Inverter's operation panel, LCD operation panel (FR-LU08), and enclosure surface operation panel (FR-PA07)
Parameter unit	Parameter unit (FR-PU07)
PU	Operation panel and parameter unit
Inverter	Mitsubishi Electric FR-D800 series inverter
D800	Standard model (RS-485 communication)
Pr.	Parameter number (Number assigned to function)
PU operation	Operation using the PU (operation panel / parameter unit)
External operation	Operation using the control circuit signals
Combined operation	Combined operation using the PU (operation panel / parameter unit) and External operation
Mitsubishi Electric standard efficiency motor	SF-JR
Mitsubishi Electric constant-torque motor	SF-HRCA
Mitsubishi Electric high-performance energy-saving motor	SF-PR
Mitsubishi Electric PM motor	EM-A

◆ Trademarks

- MODBUS is a registered trademark of SCHNEIDER ELECTRIC USA, INC.
- Other company and product names herein are the trademarks and registered trademarks of their respective owners.

◆ Notes on descriptions in this Instruction Manual

- Connection diagrams in this Instruction Manual appear with the control logic of the input terminals as sink logic, unless otherwise specified. (For the control logic, refer to [page 62](#).)

◆ Harmonic Suppression Guidelines

All the models of the inverters used by specific consumers are covered by "the Harmonic Suppression Guidelines for Consumers Who Receive High Voltage or Special High Voltage". (For details, refer to [page 93](#).)

1.1 Product checking

Unpack the product and check the rating plate and the capacity plate of the inverter to ensure that the model agrees with the order and the product is intact.

◆ Inverter model

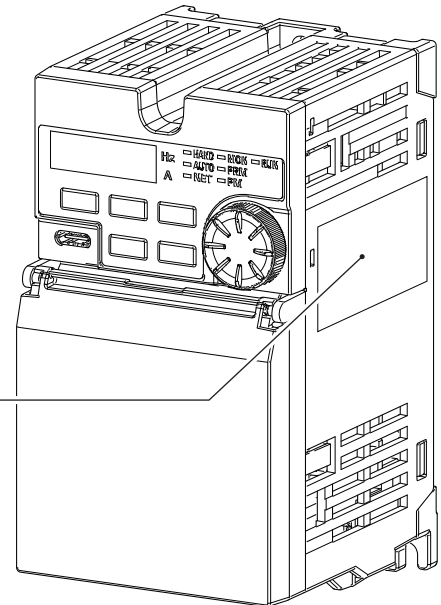
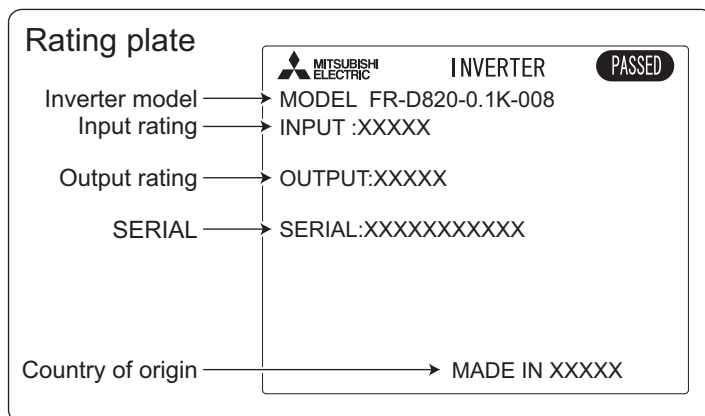
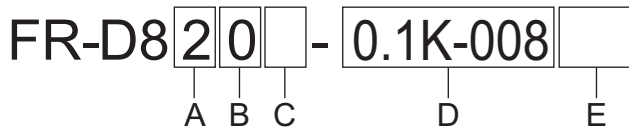

- A: The voltage class is shown.

Symbol	Voltage class
1	100 V class
2	200 V class
4	400 V class

- B: The protective structure is shown.

Symbol	Protective structure
0	Open type (IP20)

- C: The number of phases of the power source is shown.

Symbol	Description
None	Three-phase input
S	Single-phase input
W	Single-phase input (double voltage output)

- D: The applicable motor capacity and the inverter rated current are shown.

Symbol	Description
Example) 200 V class 0.1K-008 to 15K-580	Applicable motor capacity (ND) (kW) - Inverter rated current (ND) (A)

- E: Availability of circuit board coating is shown.

Symbol	Circuit board coating ^{*1}
None	Without coating
-60	With coating

*1 Conforming to IEC 60721-3-3:1994 3C2/3S2

◆ How to read the SERIAL number

Rating plate example

□□ ○○ ○ ○○○○○○
 Symbol Year Month Control number

SERIAL

The SERIAL consists of two symbols, three characters indicating the production year and month, and six characters indicating the control number.

The last two digits of the production year are indicated as the Year, and the Month is indicated by 1 to 9, X (October), Y (November), or Z (December).

◆ Specification differences by the country of origin

The rated frequency (initial setting) and the control logic (initial status) of the input signal differ depending on the country of origin.

For the country of origin, refer to the rating plate ([page 12](#)).

Country of origin	Rated frequency (initial setting)	Control logic	
		Input signal (initial status)	Safety stop signal
MADE IN JAPAN	60 Hz	Sink logic	Source logic (fixed)
MADE IN CHINA	50 Hz	Source logic	

1.2 Component names

Component names are as follows.

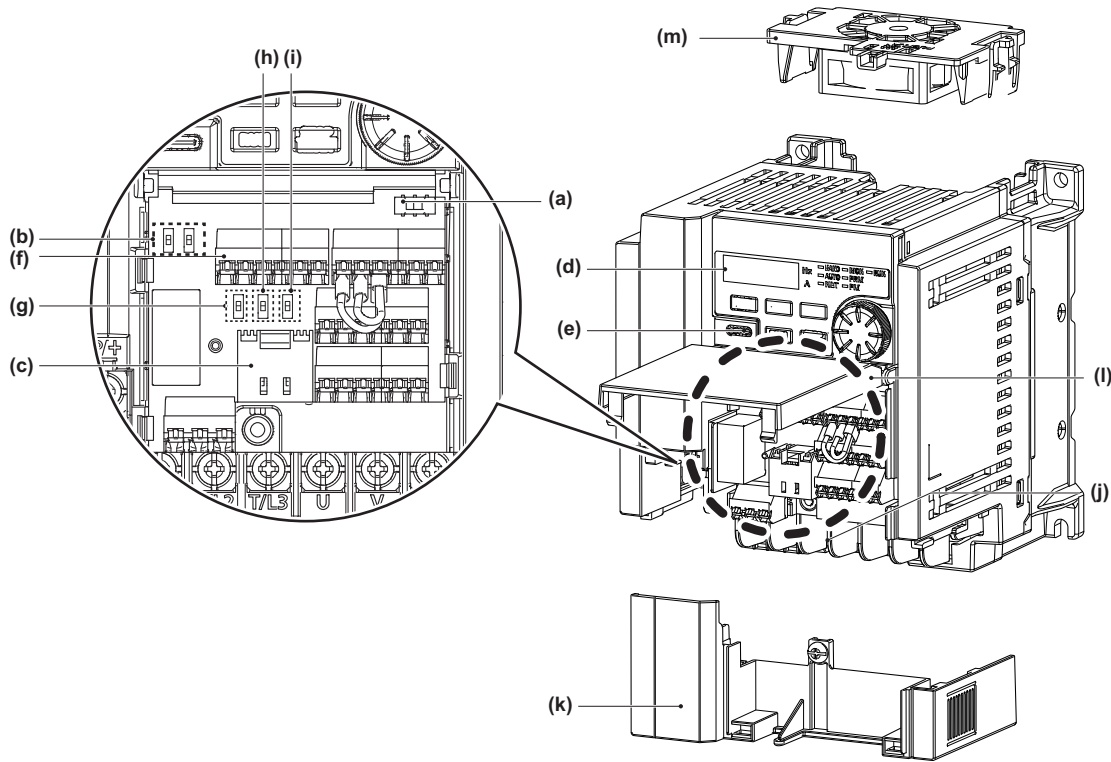

Symbol	Name	Description	Refer to page
(a)	Control logic switch	Select the sink logic (SINK) or the source logic (SOURCE).	62
(b)	Voltage/current input switches (SW1, SW2)	Select voltage or current for the input via terminals 2 and 4.	*1
(c)	PU connector	Used for the RS-485 communication.	70
(d)	Operation panel	Operates and monitors the inverter. The operation panel cannot be removed from the inverter.	*1
(e)	USB Type-C connector	Connector for a personal computer. Enables communication with FR Configurator2.	77
(f)	Control circuit terminal block	Connects cables for the control circuit.	59
(g)	Terminating resistor switch (SW4)	Switches OFF or ON the internal terminating resistor.	—
(h)	R+/FU switch (SW5)	Terminal R+/FU functions as the open collector output terminal FU in the initial setting. To use the terminal as terminal R+ for RS-485 communication, set the switch to R+.	60
(i)	R-/SD switch (SW6)	Terminal R-/SD functions as the common terminal SD for contact input terminals in the initial setting. To use the terminal as terminal R- for RS-485 communication, set the switch to R-.	62
(j)	Main circuit terminal block	Connects cables for the main circuit.	50
(k)	Comb-shaped wiring cover	This cover is removable without unplugging cables. Provided with the FR-D820-1.5K-070 or higher, the FR-D820S-1.5K-070 or higher, the FR-D840-2.2K-050 or higher, and the FR-D810W-0.75K-042 or higher.	22
(l)	Front cover	Flip up this cover for wiring.	22
(m)	Cooling fan	Cools the inverter (FR-D820-2.2K-100 or higher, FR-D840-2.2K-050 or higher, FR-D820S-2.2K-100) ^{*3}	*2

*1 Refer to the Instruction Manual (Function).

*2 Refer to the Instruction Manual (Maintenance).

*3 For the FR-D820-2.2K-100, FR-D820-3.7K-165, the FR-D840-2.2K-050, the FR-D840-3.7K-081, and the FR-D820S-2.2K-100, the fan unit is provided (the fan and its cover are integrated).

1.3 Operation steps

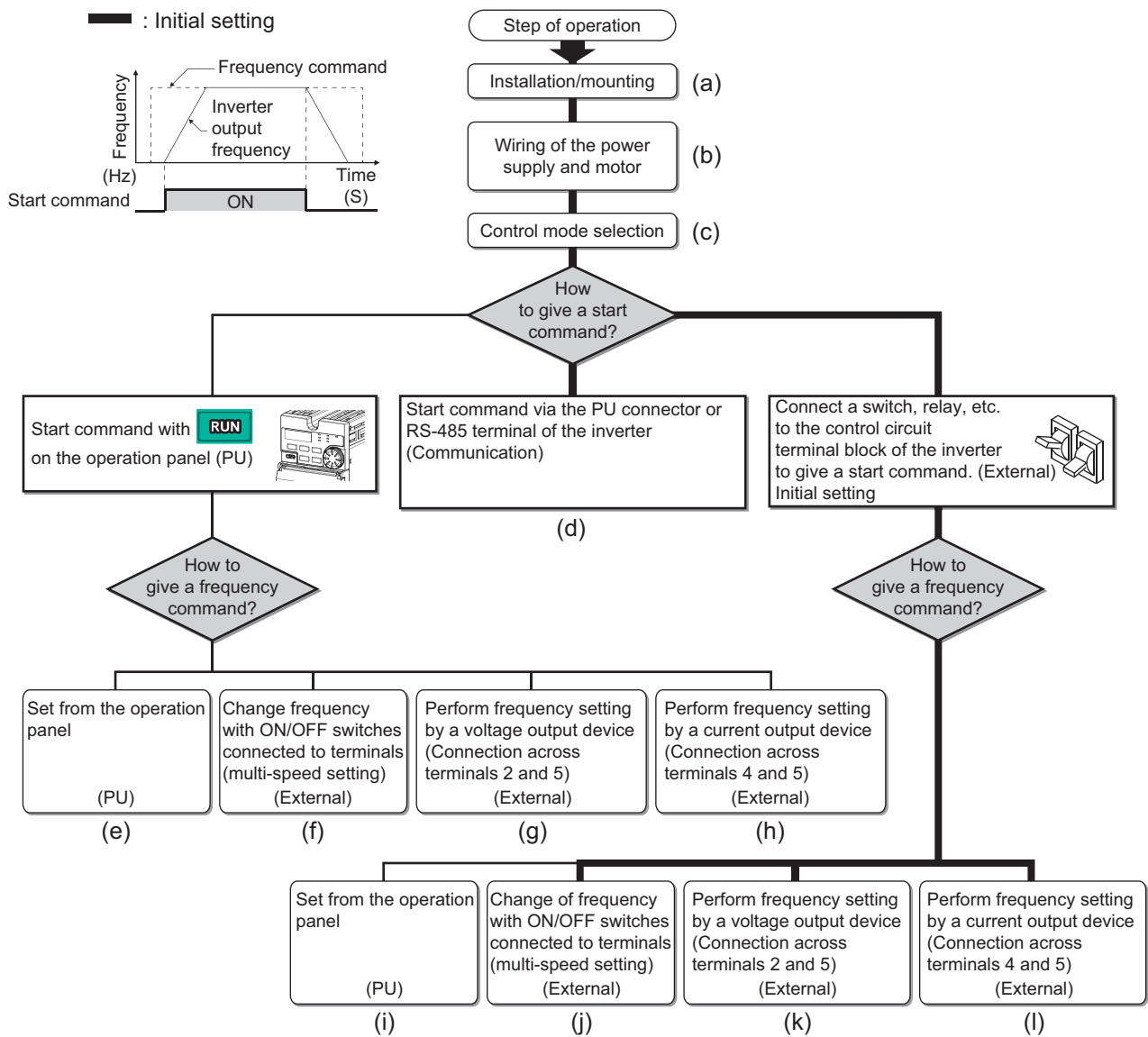

Symbol	Overview	Refer to page
(a)	Install the inverter.	page 35
(b)	Perform wiring for the power supply and the motor.	page 50
(c)	Select the control method (V/F control, Advanced magnetic flux vector control, and PM sensorless vector control).	Instruction Manual (Function)
(d)	Give the start command via communication.	Instruction Manual (Communication)
(e)	Give both the start and frequency commands from the PU. (PU operation mode)	Instruction Manual (Function)
(f)	Give the start command from the PU and the frequency command via terminals RH, RM, and RL. (External/PU combined operation mode 2)	Instruction Manual (Function)
(g)	Give the start command from the PU and the frequency command by voltage input via terminal 2. (External/PU combined operation mode 2)	Instruction Manual (Function)
(h)	Give the start command from the PU and the frequency command by current input via terminal 4. (External/PU combined operation mode 2)	Instruction Manual (Function)
(i)	Give the start command via terminal STF or STR and the frequency command from the PU. (External/PU combined operation mode 1)	Instruction Manual (Function)
(j)	Give the start command via terminal STF or STR and the frequency command via terminals RH, RM, and RL. (External operation mode)	Instruction Manual (Function)
(k)	Give the start command via terminal STF or STR and the frequency command by voltage input via terminal 2. (External operation mode)	Instruction Manual (Function)
(l)	Give the start command via terminal STF or STR and the frequency command by current input via terminal 4. (External operation mode)	Instruction Manual (Function)

1.4 Related manuals

When using this inverter for the first time, prepare the following manuals as required and use the inverter safely. The latest version of e-Manual Viewer and the latest PDF manuals can be downloaded from the Mitsubishi Electric FA Japanese Website. https://www.MitsubishiElectric.co.jp/fa/download/search.do?mode=manual&kisyu=inv&sort=0&style=0&lang=2&category1=FREQROL-D800&category2=0&filter_readme=0&filter_discontinued=0&filter_bundled=0

Point 

- e-Manual refers to the Mitsubishi FA electronic book manuals that can be browsed using a dedicated tool.
- e-Manual has the following features:
 - Required information can be cross-searched in multiple manuals.
 - Pages that users often browse can be bookmarked.

Manuals related to the FR-D800 inverter are shown in the following table.

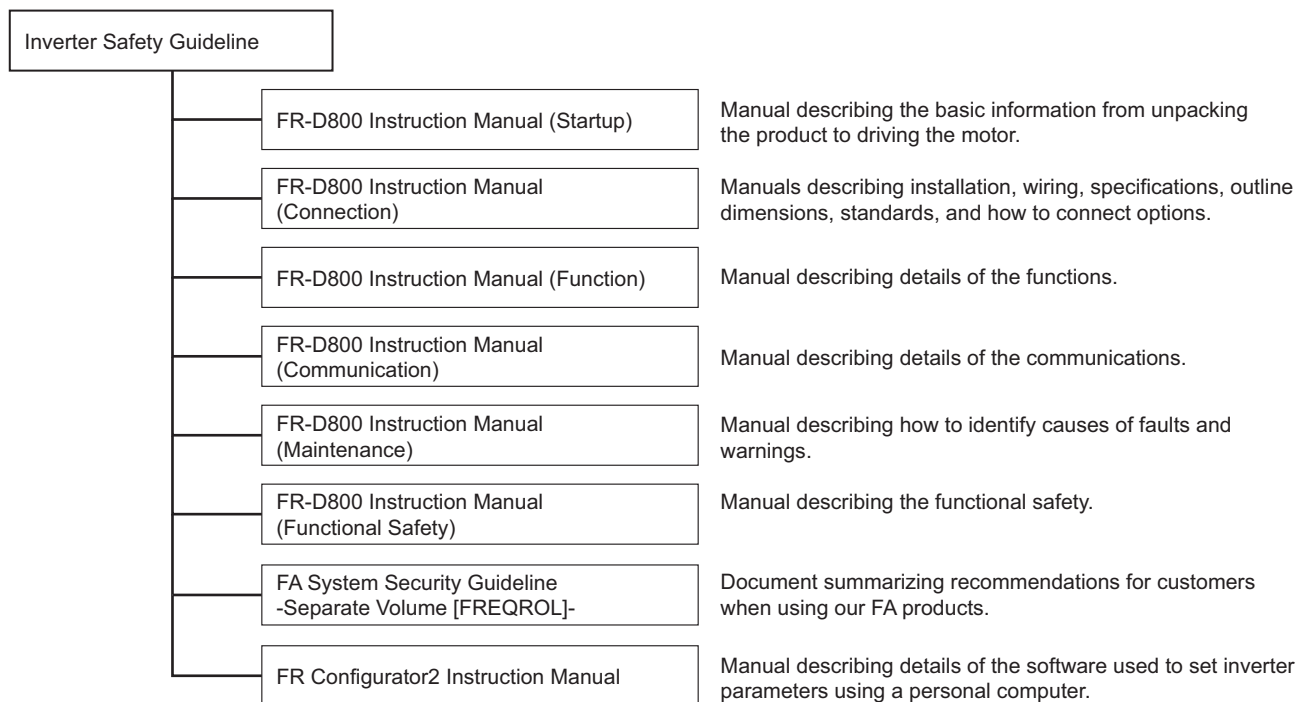

Name	Manual number
FR-D800 Inverter Safety Guideline	IB-0601019
FR-D800 Instruction Manual (Startup)	IB-0601026ENG
FR-D800 Instruction Manual (Function)	IB-0601034ENG
FR-D800 Instruction Manual (Communication)	IB-0601039ENG
FR-D800 Instruction Manual (Maintenance)	IB-0601044ENG
FR-D800 Instruction Manual (Functional Safety)	BCN-A23498-007(E)
FA System Security Guideline -Separate Volume [FREQROL]-	BCN-C22005-1054
FR Configurator2 Instruction Manual	IB-0600516ENG

2 Installation and Wiring

This chapter explains the installation and the wiring of this product.
Always read the instructions before use.

2.1 Peripheral devices

2.1.1 Inverter and peripheral devices

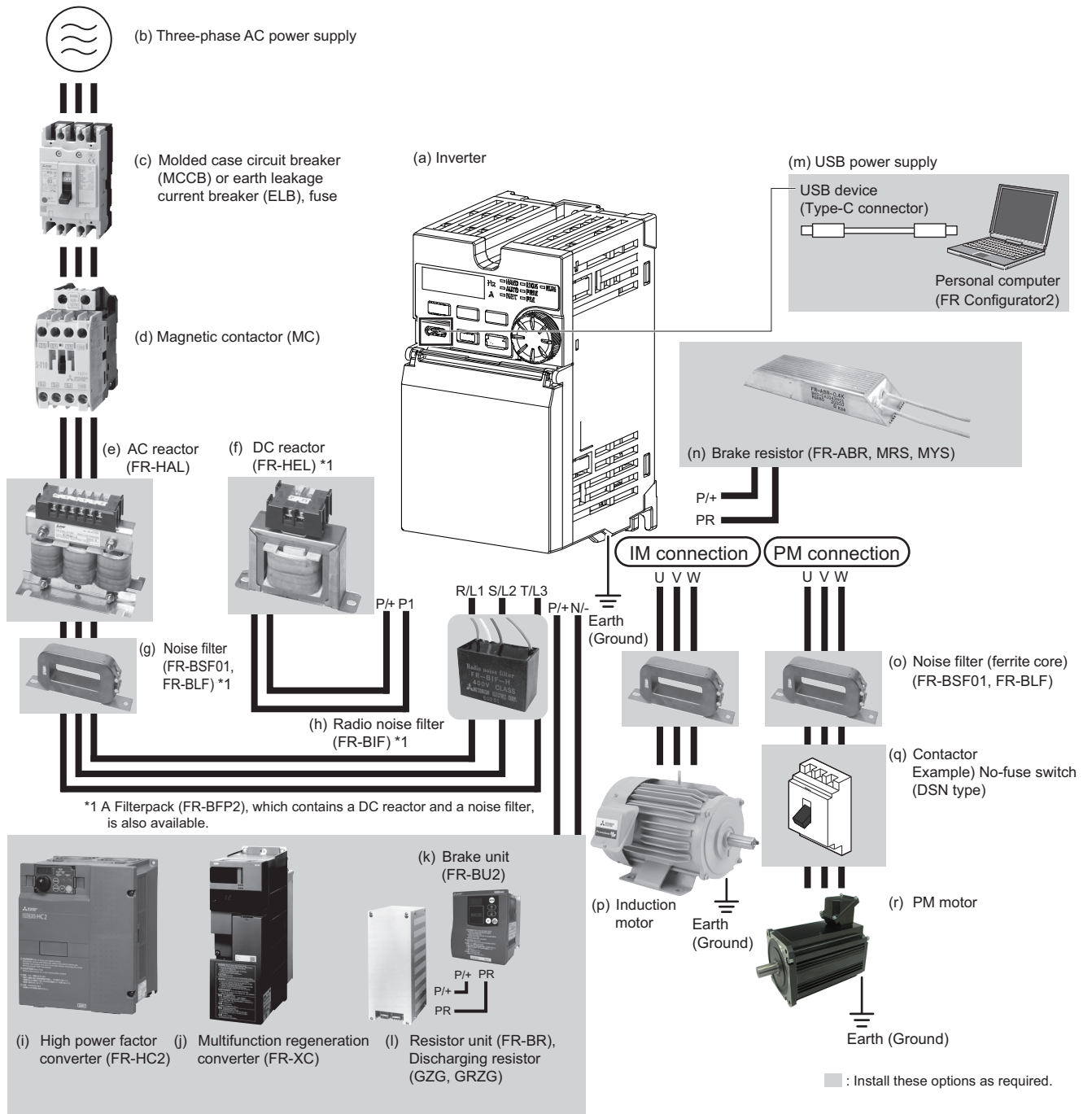

Symbol	Name	Overview	Refer to page
(a)	Inverter (FR-D800)	The life of the inverter is influenced by the surrounding air temperature. The surrounding air temperature should be as low as possible within the permissible range. This must be noted especially when the inverter is installed in an enclosure. Incorrect wiring may lead to damage of the inverter. The control signal lines must be kept fully away from the main circuit lines to protect them from noise.	35, 46
(b)	Three-phase AC power supply	Must be within the permissible power supply specifications of the inverter.	107
(c)	Molded case circuit breaker (MCCB), earth leakage circuit breaker (ELB), or fuse	Must be selected carefully since an inrush current flows in the inverter at power ON.	19
(d)	Magnetic contactor (MC)	Install this to ensure safety. Do not use this to start and stop the inverter. Doing so will shorten the life of the inverter.	98
(e)	AC reactor (FR-HAL)	Install this to suppress harmonics and to improve the power factor. An AC reactor (FR-HAL) (option) is required when installing the inverter near a large power supply system (500 kVA or more). Under such condition, the inverter may be damaged if you do not use a reactor. Select a reactor according to the applied motor capacity. (When using a motor with capacity lower than 0.4 kW, select the reactor for a 0.4 kW motor. For the single-phase 200 V power input models, select the reactor whose capacity is one rank higher than the motor capacity. For the single-phase 100 V power input models, select the reactor whose capacity is three ranks higher than the motor capacity.)	86, 97
(f)	DC reactor (FR-HEL)	Install this to suppress harmonics and to improve the power factor. Select a reactor according to the applied motor capacity. (When using a motor with capacity lower than 0.4 kW, select the reactor for a 0.4kW motor. For the single-phase 200 V power input models, select the reactor whose capacity is one rank higher than the motor capacity.) When using a DC reactor, remove the jumper across terminals P/+ and P1 before connecting a DC reactor to the inverter.*1	87
(g)	Noise filter (ferrite core) (FR-BSF01, FR-BLF)	Install this to reduce the electromagnetic noise generated from the inverter.	90
(h)	Radio noise filter (FR-BIF)	Install this to reduce the radio noise.	—
(i)	High power factor converter (FR-HC2)	Suppresses the power supply harmonics significantly. Install this as required.	84
(j)	Multifunction regeneration converter (FR-XC)	Provides a large braking capability. Install this as required.	85
(k)	Brake unit (FR-BU2, FR-BU, BU)	Allows the inverter to provide the optimal regenerative braking capability.	82
(l)	Resistor unit (FR-BR), discharge resistor (GZG, GRZG)	Install this as required.	
(m)	USB connection	Connect between the inverter and a personal computer with a USB Type-C cable.	77
(n)	Brake resistor (FR-ABR, MRS, MYS)	Increases the braking capability. (0.4K or higher)	78
(o)	Noise filter (ferrite core) (FR-BSF01, FR-BLF)	Install this to reduce the electromagnetic noise generated from the inverter. The noise filter is effective in the range from about 0.5 to 5 MHz. A wire should be wound four turns at maximum.	90
(p)	Induction motor	Connect a squirrel-cage induction motor.	—
(q)	Contactors Example) No-fuse switch (DSN type)	Connect this for an application where a PM motor is driven by the load even while the inverter power is OFF. Do not open or close the contactor while the inverter is running (outputting).	—
(r)	PM motor	An IPM motor cannot be driven by the commercial power supply.	—

*1 A DC reactor (FR-HEL) cannot be connected to the single-phase 100 V power input models.

NOTE

- To prevent an electric shock, always earth (ground) the motor and inverter.
- Do not install a power factor correction capacitor, surge suppressor, or capacitor type filter on the inverter's output side. Doing so will cause the inverter shut off or damage the capacitor or surge suppressor. If any of the above devices is connected, immediately remove it. When installing a molded case circuit breaker on the output side of the inverter, contact the manufacturer of the molded case circuit breaker.

- Electromagnetic wave interference:
The input/output (main circuit) of the inverter includes high frequency components, which may interfere with the communication devices (such as AM radios) used near the inverter. Connect the optional radio noise filter FR-BIF (for use in the input side only), line noise filter FR-BSF01/FR-BLF, Filterpack, or EMC filter to minimize interference. A Filterpack (FR-BFP2), which contains a DC reactor and a noise filter, is also available.
- For details of options and peripheral devices, refer to the respective Instruction Manual.
- A PM motor cannot be driven by the commercial power supply.
- A PM motor is a motor with permanent magnets embedded inside. High voltage is generated at the motor terminals while the motor is running. Before closing the contactor at the output side, make sure that the inverter power is ON and the motor is stopped.

2.1.2 Peripheral devices

Check the model of the inverter you purchased. Appropriate peripheral devices must be selected according to the capacity. Refer to the following table for right selection.

◆ Molded case circuit breaker / earth leakage circuit breaker

- This is a matrix showing the rated current of the molded case circuit breaker (MCCB) or earth leakage circuit breaker (ELB) (NF or NV type) according to the selected inverter and rating.

Voltage	Inverter model	Without AC/DC reactor		With AC/DC reactor	
		SLD	ND	SLD	ND
Three-phase 200 V class	FR-D820-0.1K-008	5 A	5 A	5 A	5 A
	FR-D820-0.2K-014	5 A	5 A	5 A	5 A
	FR-D820-0.4K-025	10 A	5 A	5 A	5 A
	FR-D820-0.75K-042	15 A	10 A	10 A	5 A
	FR-D820-1.5K-070	20 A	15 A	15 A	10 A
	FR-D820-2.2K-100	30 A	20 A	30 A	15 A
	FR-D820-3.7K-165	50 A	30 A	40 A	30 A
	FR-D820-5.5K-238	60 A	50 A	50 A	40 A
	FR-D820-7.5K-318	75 A	60 A	75 A	50 A
	FR-D820-11K-450	125 A	75 A	100 A	75 A
	FR-D820-15K-580	150 A	125 A	125 A	100 A
Three-phase 400 V class	FR-D840-0.4K-012	5 A	5 A	5 A	5 A
	FR-D840-0.75K-022	10 A	5 A	10 A	5 A
	FR-D840-1.5K-037	15 A	10 A	10 A	10 A
	FR-D840-2.2K-050	20 A	15 A	15 A	10 A
	FR-D840-3.7K-081	30 A	20 A	20 A	15 A
	FR-D840-5.5K-120	30 A	30 A	30 A	20 A
	FR-D840-7.5K-163	50 A	30 A	40 A	30 A
	FR-D840-11K-230	60 A	50 A	50 A	40 A
	FR-D840-15K-295	75 A	60 A	60 A	50 A
Single-phase 200 V class	FR-D820S-0.1K-008	—	5 A	—	5 A
	FR-D820S-0.2K-014	—	5 A	—	5 A
	FR-D820S-0.4K-025	—	10 A	—	10 A
	FR-D820S-0.75K-042	—	15 A	—	10 A
	FR-D820S-1.5K-070	—	20 A	—	20 A
	FR-D820S-2.2K-100	—	40 A	—	30 A
Single-phase 100 V class	FR-D810W-0.1K-008	—	10 A	—	5 A
	FR-D810W-0.2K-014	—	10 A	—	10 A
	FR-D810W-0.4K-025	—	15 A	—	15 A
	FR-D810W-0.75K-042	—	30 A	—	20 A

NOTE

- Select an MCCB according to the power supply capacity.
- Install one MCCB per inverter.

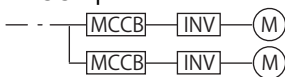

- For the use in the United States or Canada, refer to "Instructions for UL and cUL" in the document enclosed with the product and select appropriate fuses.
- When the inverter capacity is larger than the motor capacity, select the MCCB and the MC according to the inverter model, and select cables and the reactor according to the motor output. Incorrect selection may cause an inrush current at power ON, resulting in output shutoff by the breaker. Cables and reactors are to be selected according to the motor output as the output current varies depending on the motor output. When the motor output is small, the output current is also small. Therefore, select cables and reactors according to the motor output. However, output shutoff by the MCCB may be disabled if the difference between the inverter capacity and the motor capacity is too large.
- When the breaker installed on the inverter input side is shut off, check for the wiring fault (short circuit), damage to internal parts of the inverter, etc. The cause of the output shutoff must be identified and removed before turning ON the power of the breaker.

◆ Magnetic contactor at the inverter's input line

- This is a matrix showing the model name of the Mitsubishi magnetic contactor to be installed at the inverter's input line according to the selected inverter and rating.

Voltage	Inverter model	Without AC/DC reactor		With AC/DC reactor	
		SLD	ND	SLD	ND
Three-phase 200 V class	FR-D820-0.1K-008	S-T10	S-T10	S-T10	S-T10
	FR-D820-0.2K-014	S-T10	S-T10	S-T10	S-T10
	FR-D820-0.4K-025	S-T10	S-T10	S-T10	S-T10
	FR-D820-0.75K-042	S-T10	S-T10	S-T10	S-T10
	FR-D820-1.5K-070	S-T10	S-T10	S-T10	S-T10
	FR-D820-2.2K-100	S-T21	S-T10	S-T10	S-T10
	FR-D820-3.7K-165	S-T35	S-T21	S-T21	S-T10
	FR-D820-5.5K-238	S-T35	S-T35	S-T21	S-T21
	FR-D820-7.5K-318	S-T35	S-T35	S-T35	S-T35
	FR-D820-11K-450	S-T50	S-T35	S-T50	S-T35
FR-D820-15K-580	S-T65	S-T50	S-T50	S-T50	
Three-phase 400 V class	FR-D840-0.4K-012	S-T10	S-T10	S-T10	S-T10
	FR-D840-0.75K-022	S-T10	S-T10	S-T10	S-T10
	FR-D840-1.5K-037	S-T10	S-T10	S-T10	S-T10
	FR-D840-2.2K-050	S-T12	S-T10	S-T10	S-T10
	FR-D840-3.7K-081	S-T21	S-T10	S-T12	S-T10
	FR-D840-5.5K-120	S-T21	S-T21	S-T21	S-T12
	FR-D840-7.5K-163	S-T21	S-T21	S-T21	S-T21
	FR-D840-11K-230	S-T21	S-T21	S-T21	S-T21
Single-phase 200 V class	FR-D820S-0.1K-008	—	S-T10	—	S-T10
	FR-D820S-0.2K-014	—	S-T10	—	S-T10
	FR-D820S-0.4K-025	—	S-T10	—	S-T10
	FR-D820S-0.75K-042	—	S-T10	—	S-T10
	FR-D820S-1.5K-070	—	S-T10	—	S-T10
	FR-D820S-2.2K-100	—	S-T21	—	S-T10
Single-phase 100 V class	FR-D810W-0.1K-008	—	S-T10	—	S-T10
	FR-D810W-0.2K-014	—	S-T10	—	S-T10
	FR-D810W-0.4K-025	—	S-T10	—	S-T10
	FR-D810W-0.75K-042	—	S-T10	—	S-T10

NOTE

- The matrix shows the magnetic contactor selected according to the standards of Japan Electrical Manufacturers' Association (JEM standards) for AC-1 class. The electrical durability of magnetic contactor is 500,000 times. When the MC is used for emergency stops during motor driving, the electrical durability is 25 times. If using the MC for emergency stop during motor driving, select the MC for the inverter input current according to the rated current against JEM 1038 standards for AC-3 class. When installing an MC on the inverter output side to switch to the commercial-power supply operation while running a general-purpose motor, select the MC for the rated motor current according to the rated current against JEM 1038 standards for AC-3 class.
- When the inverter capacity is larger than the motor capacity, select the MCCB and the MC according to the inverter model, and select cables and the reactor according to the motor output. Incorrect selection may cause an inrush current at power ON, resulting in output shutoff by the breaker. Cables and reactors are to be selected according to the motor output as the output current varies depending on the motor output. When the motor output is small, the output current is also small. Therefore, select cables and reactors according to the motor output. However, output shutoff by the MCCB may be disabled if the difference between the inverter capacity and the motor capacity is too large.
- When the breaker installed on the inverter input side is shut off, check for the wiring fault (short circuit), damage to internal parts of the inverter, etc. The cause of the output shutoff must be identified and removed before turning ON the power of the breaker.

2.2 Opening/closing of the front cover and removal/reinstallation of the combed-shaped wiring cover

◆ How to open the front cover (FR-D820-0.75K-042 or lower, FR-D840-1.5K-037 or lower, FR-D820S-0.75K-042 or lower, FR-D810W-0.4K-025 or lower)

- Example of FR-D820-0.1K-008

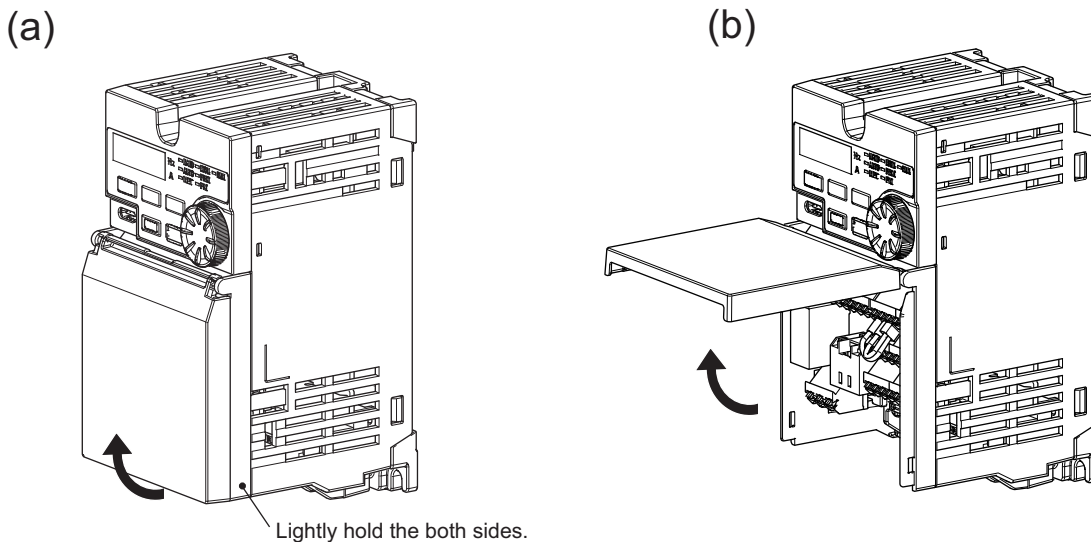

- (a) While lightly holding the lower parts of the both sides of the inverter, pull open the front cover using its upper end as a support. To open/close the cover for side-by-side installation, refer to [page 30](#)
- (b) The front cover can be held fully open.

◆ How to open the front cover (FR-D820-1.5K-070 to 7.5K-318, FR-D840-2.2K-050 to 7.5K-163, FR-D820S-1.5K-070 or higher, FR-D810W-0.75K-042)

- Example of FR-D820-1.5K-070

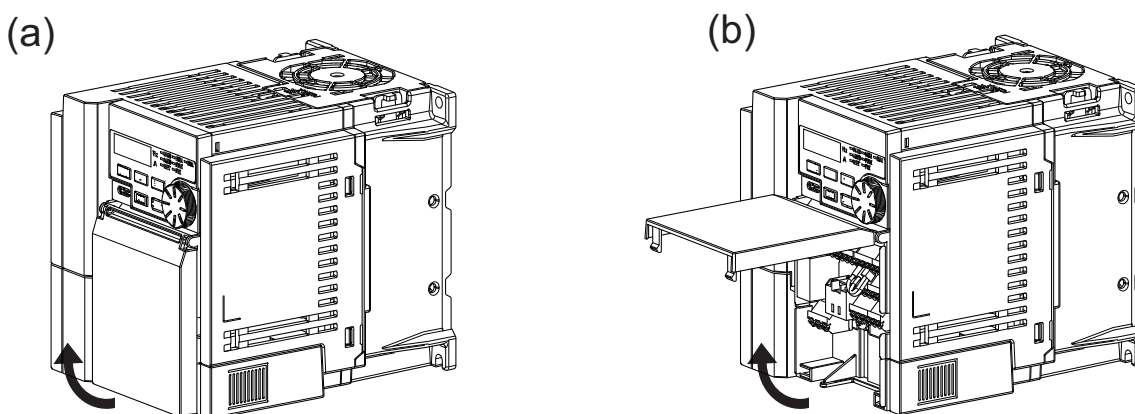

- (a) Pull open the front cover using its upper end as a support.
- (b) The front cover can be held fully open.

◆ How to open the front cover and the terminal block cover (FR-D820-11K-450 or higher, FR-D840-11K-230 or higher)

- Example of FR-D820-11K-450

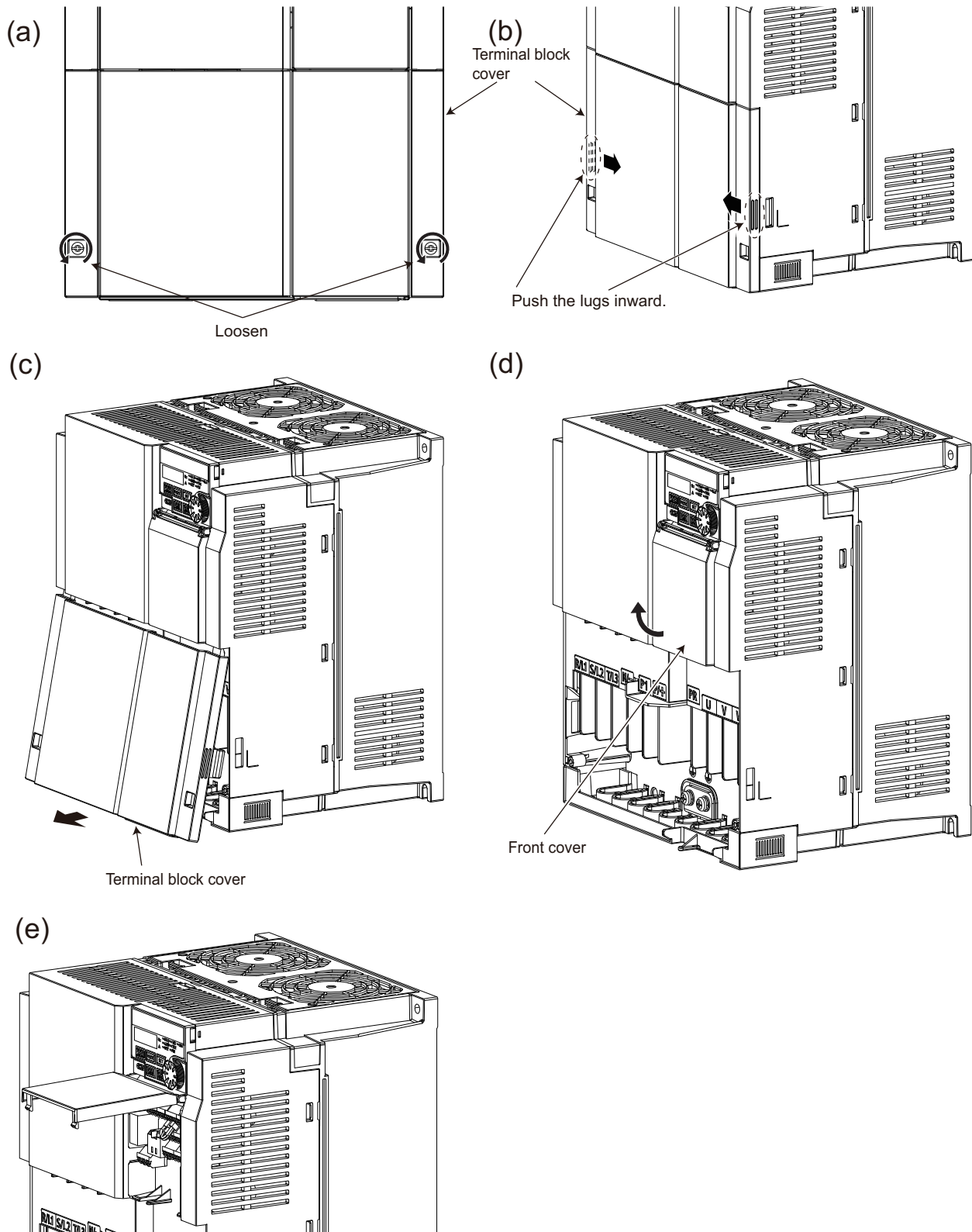

- Loosen the mounting screws of the terminal block cover.
- Push the lugs of the terminal block cover inward, as shown by the arrows in the figure above.
- Pull out the terminal block cover to remove it.
- Pull open the front cover using its upper end as a support. (To open the front cover, the terminal block cover must be removed.)
- The front cover can be held fully open.

◆ **How to close the front cover (FR-D820-0.75K-042 or lower, FR-D840-1.5K-037 or lower, FR-D820S-0.75K-042 or lower, FR-D810W-0.4K-025 or lower)**

- Example of FR-D820-0.1K-008

(a)

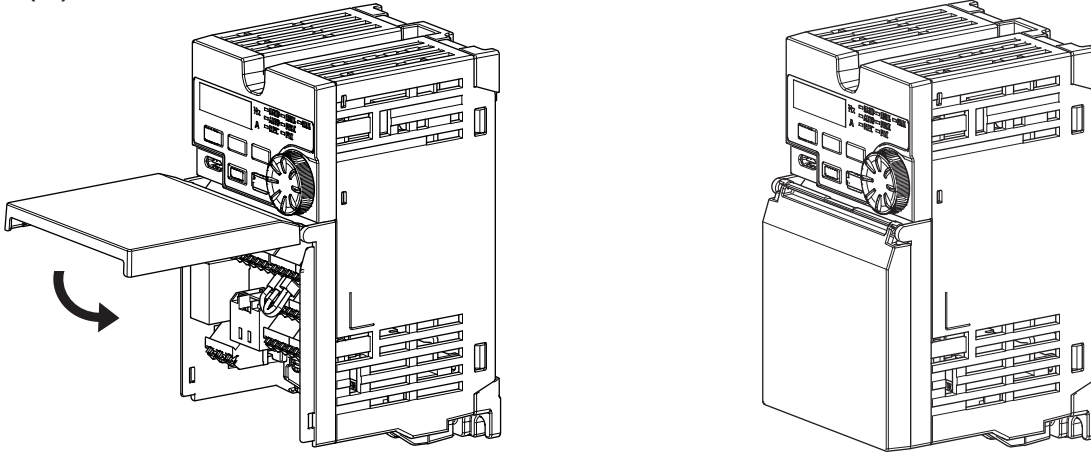

(a) Push the front cover downward using its upper end as a support to close the cover.

◆ **How to close the front cover (FR-D820-1.5K-070 to 7.5K-318, FR-D840-2.2K-050 to 7.5K-163, FR-D820S-1.5K-070 or higher, FR-D810W-0.75K-042)**

- Example of FR-D820-1.5K-070

(a)

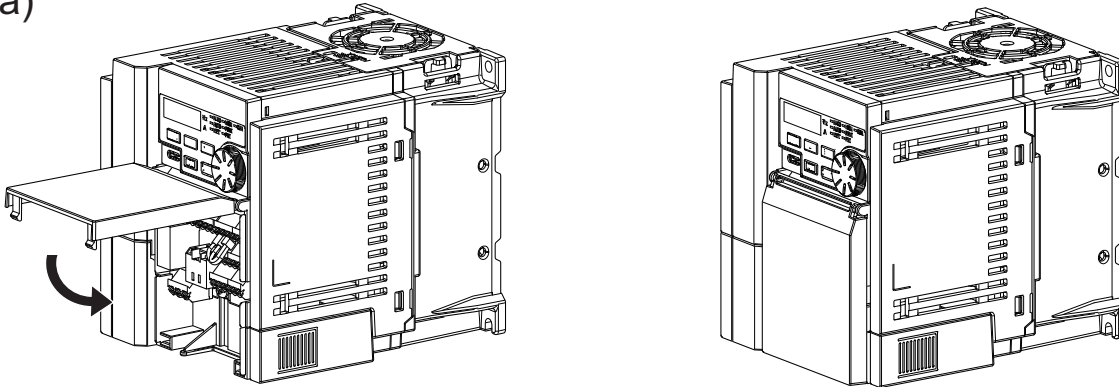

(a) Push the front cover downward using its upper end as a support to close the cover.

◆ How to close the front cover and the terminal block cover (FR-D820-11K-450 or higher, FR-D840-11K-230 or higher)

- Example of FR-D820-11K-450

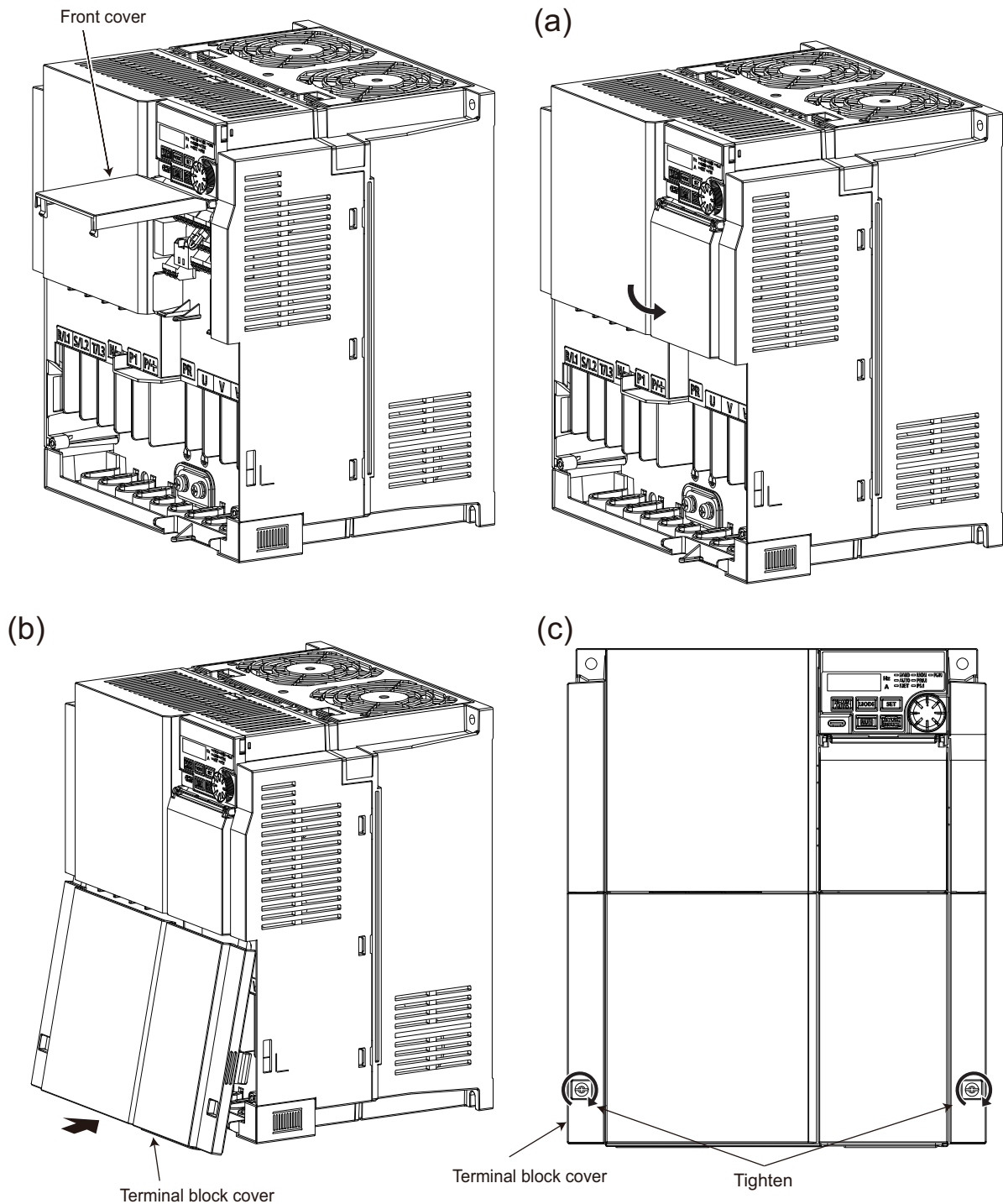

- Close the front cover.
- Reinstall the terminal block cover to the inverter. (The front cover cannot be closed after installing the terminal block cover.)
- Tighten the mounting screws of the terminal block cover. (Tightening torque: 0.6 to 0.8 N·m)

NOTE

- Fully make sure that the front cover is closed.

◆ **Removal of the front cover (FR-D820-0.75K-042 or lower, FR-D840-1.5K-037 or lower, FR-D820S-0.75K-042 or lower, FR-D810W-0.4K-025 or lower)**

- Example of FR-D820-0.1K-008

(a)

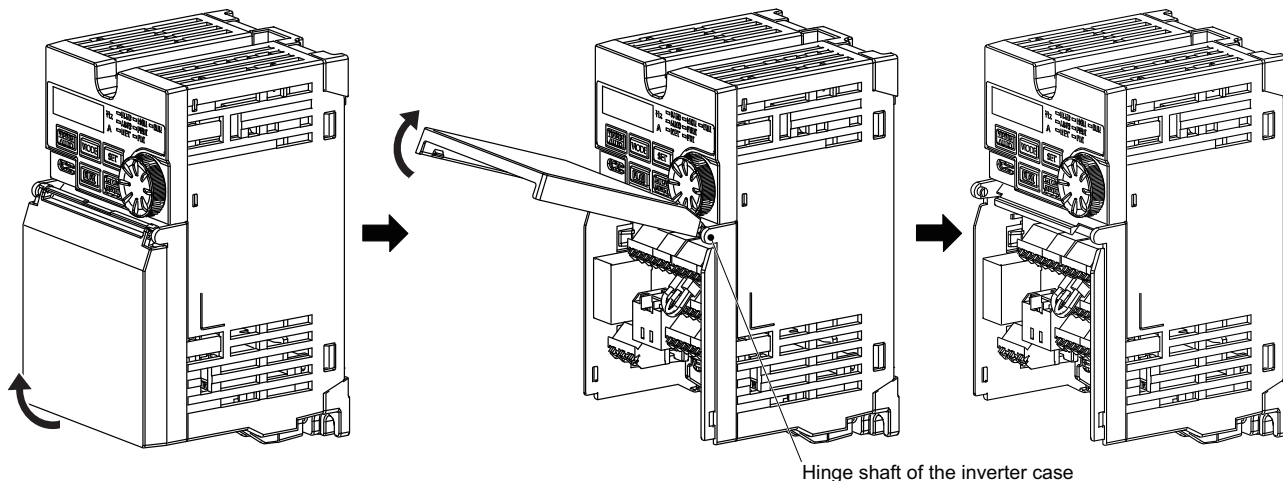

(a) Pull open the front cover 90° or more to remove it from the hinge shaft of the inverter case.

◆ **Removal of the front cover (FR-D820-1.5K-070 to 7.5K-318, FR-D840-2.2K-050 to 7.5K-163, FR-D820S-1.5K-070 or higher, FR-D810W-0.75K-042)**

- Example of FR-D820-1.5K-070

(a)

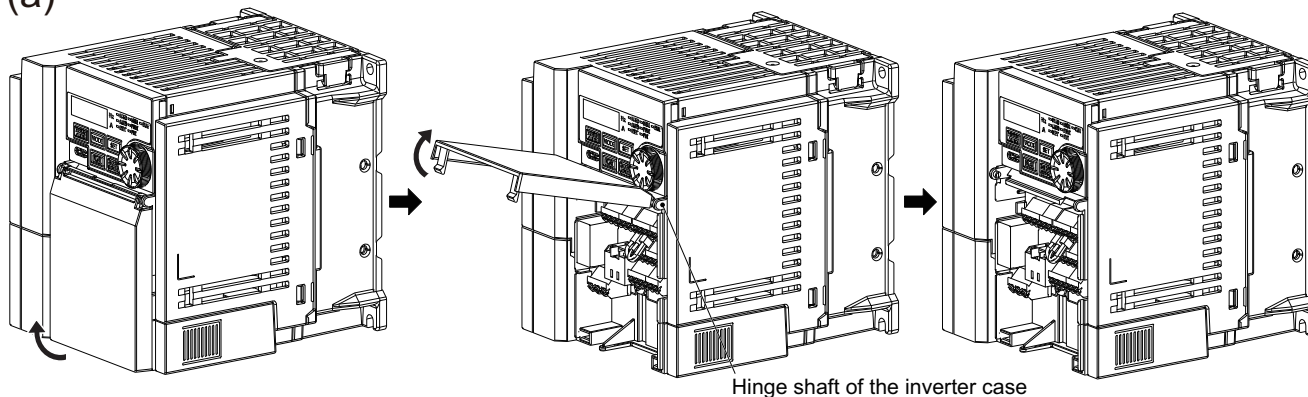

(a) Pull open the front cover 90° or more to remove it from the hinge shaft of the inverter case.

◆ Removal of the front cover (FR-D820-11K-450 or higher, FR-D840-11K-230 or higher)

- Example of FR-D820-11K-450

(a)

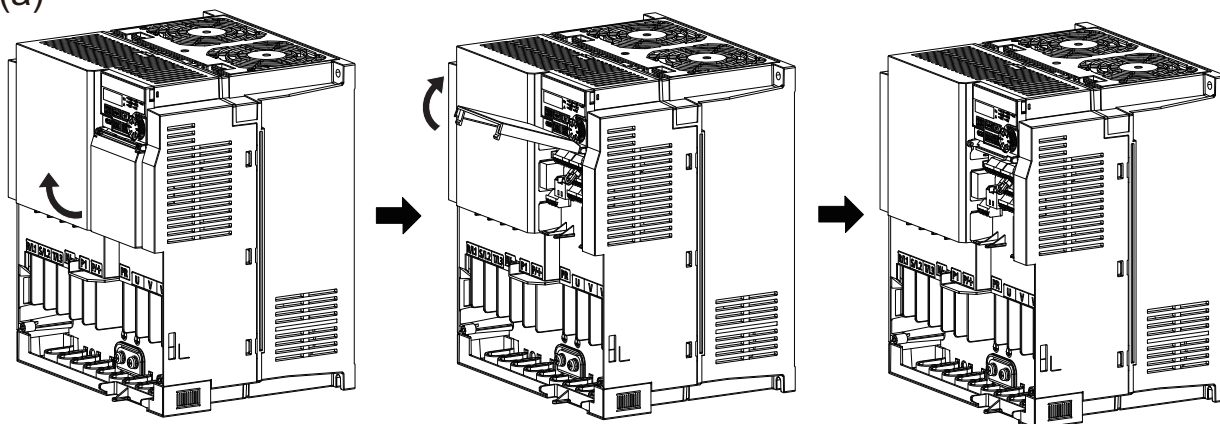

(a) With the terminal block cover removed, pull open the front cover 90° or more to remove it from the hinge shaft of the inverter case.

◆ Reinstallation of the front cover (FR-D820-0.75K-042 or lower, FR-D840-1.5K-037 or lower, FR-D820S-0.75K-042 or lower, FR-D810W-0.4K-025 or lower)

- Example of FR-D820-0.1K-008

(a)

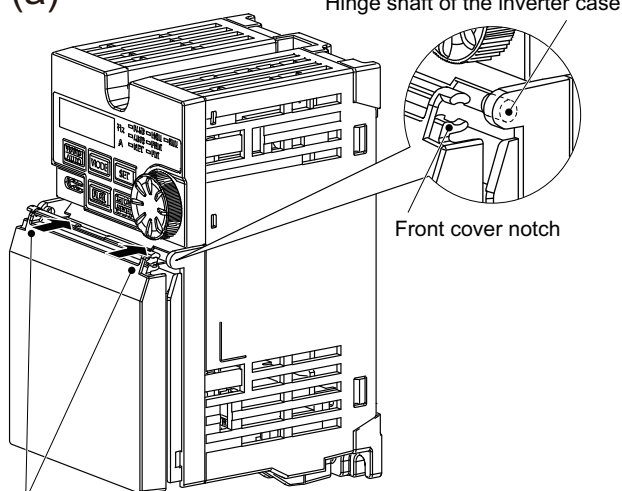

Push the upper corners of the front cover, and snap the notches onto the hinge shaft of the inverter case.

(b)

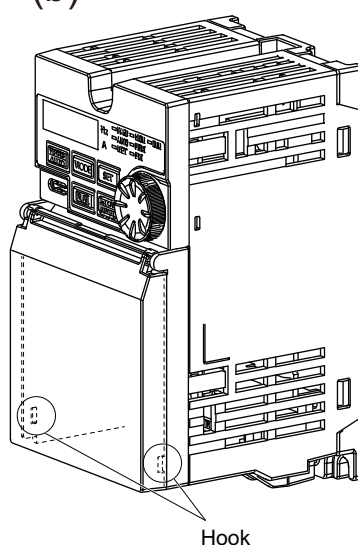

Hook

- (a) Push the upper corners of the front cover with your fingers, and snap the front cover notches into the hinge shaft of the inverter case.
 (b) Push the lower part of the front cover to snap the hooks into places.

◆ **Reinstallation of the front cover (FR-D820-1.5K-070 to 7.5K-318, FR-D840-2.2K-050 to 7.5K-163, FR-D820S-1.5K-070 or higher, FR-D810W-0.75K-042)**

- Example of FR-D820-1.5K-070

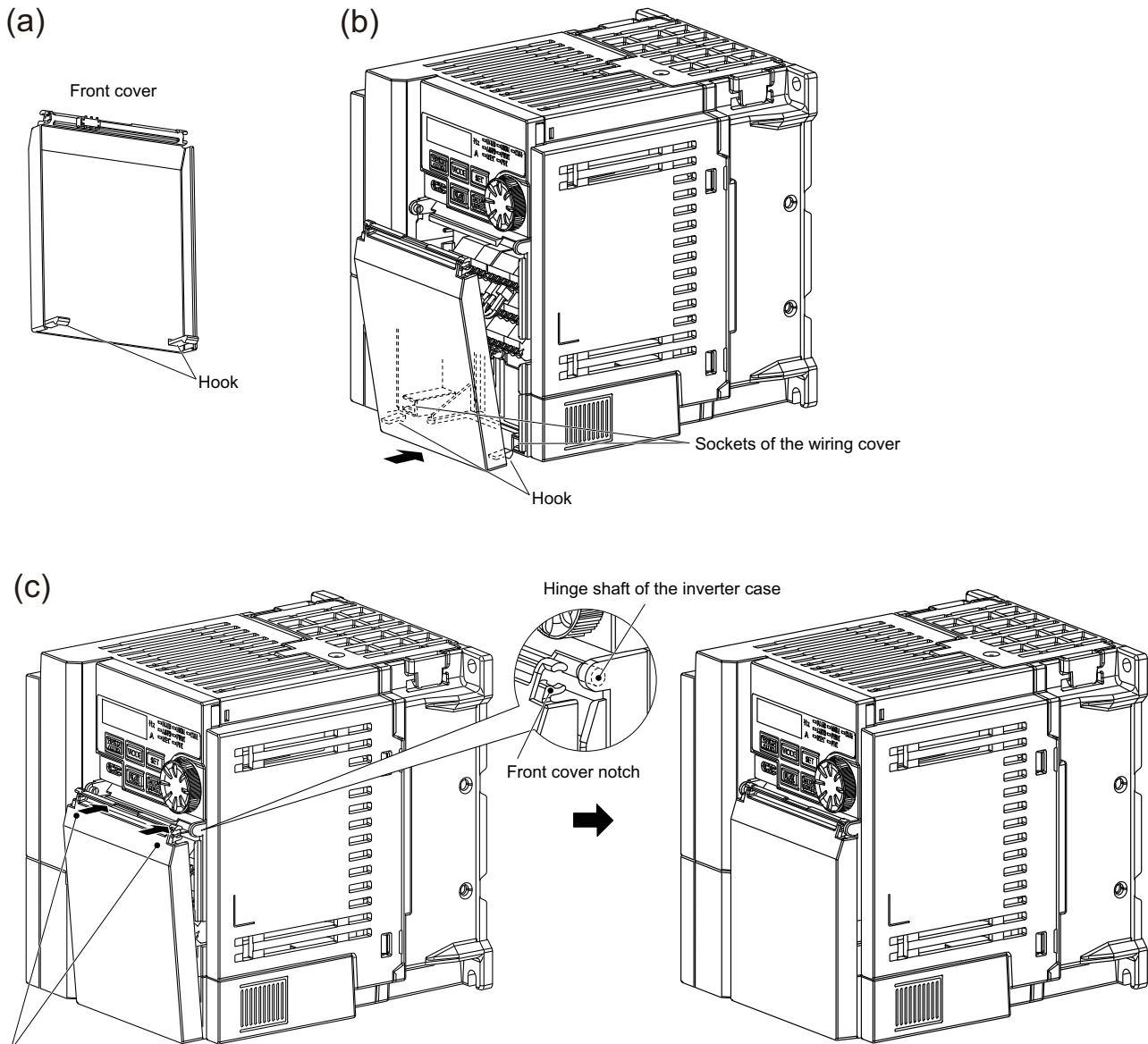

Push the upper corners of the front cover, and snap the notches onto the hinge shaft of the inverter case.

- (a) Check the position of the hooks on the rear of the cover.
- (b) Insert the hooks of the front cover into the sockets of the wiring cover.
- (c) Push the upper corners of the front cover with your fingers, and snap the front cover notches into the hinge shaft of the inverter case.

◆ Reinstallation of the front cover (FR-D820-11K-450 or higher, FR-D840-11K-230 or higher)

- Example of FR-D820-11K-450

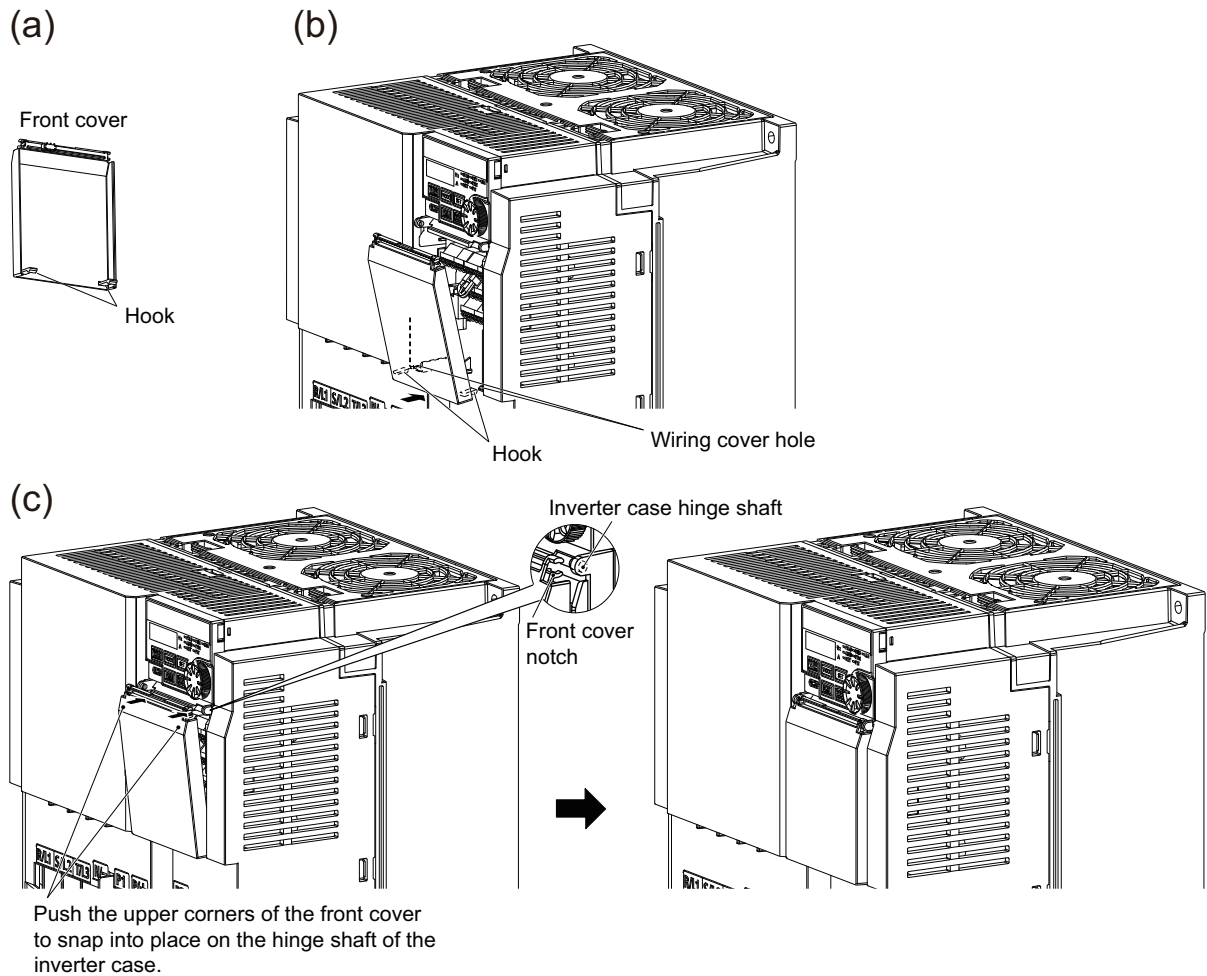

- Check the position of the hooks on the rear of the cover.
- Insert the hooks of the front cover into the sockets of the wiring cover.
- Push the upper corners of the front cover with your fingers, and snap the front cover notches into the hinge shaft of the inverter case.

◆ How to open/close the front cover for side-by-side installation (FR-D820-0.75K-042 or lower, FR-D840-1.5K-037 or lower, FR-D820S-0.75K-042 or lower, FR-D810W-0.4K-025 or lower)

- How to open

(a)

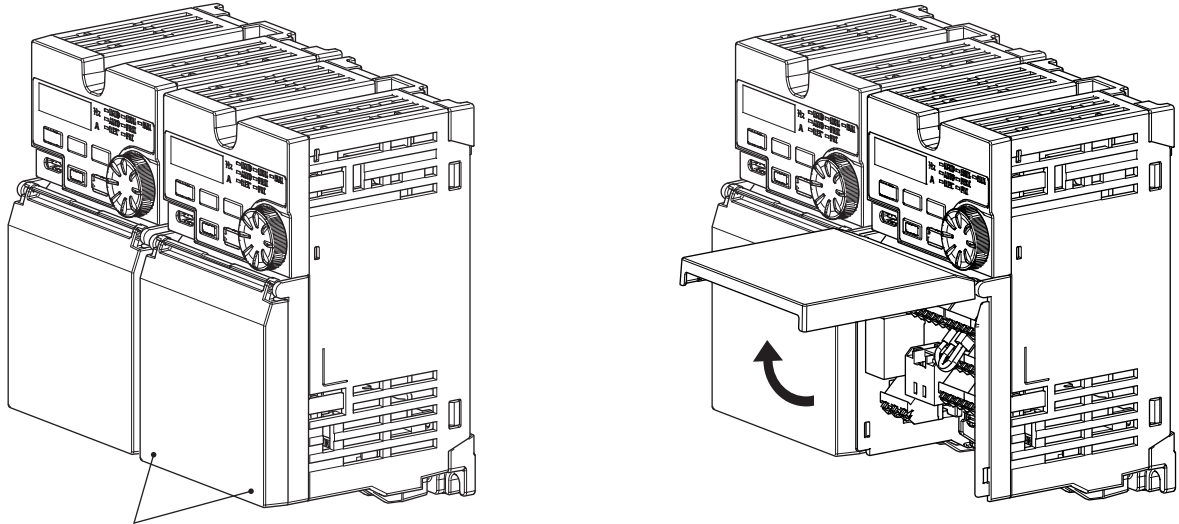

Pull the lower corners of the front cover one by one.

- (a) Slowly pull the lower corners of the front cover one by one.

- How to close

(a)

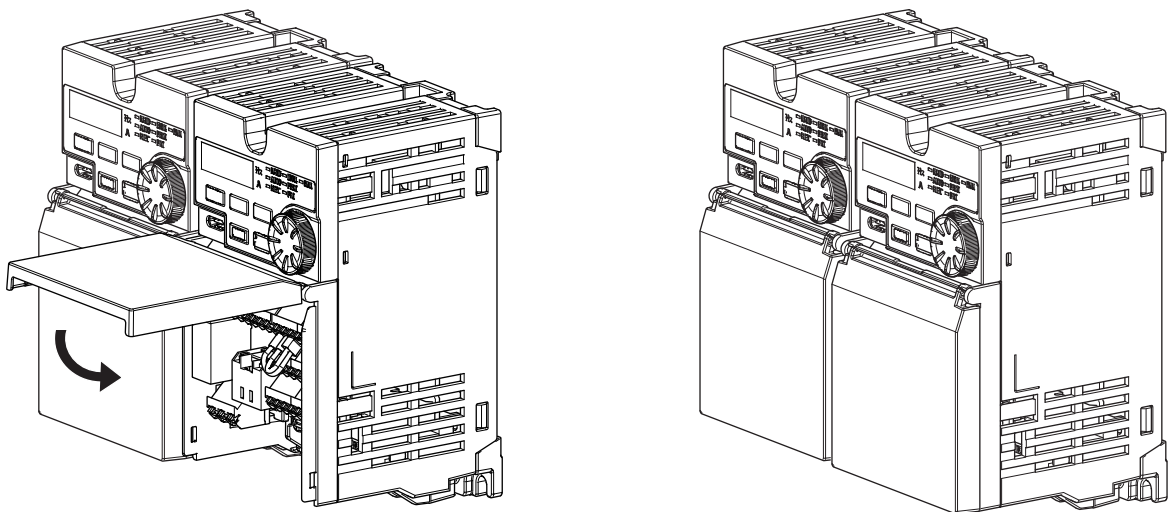

- (a) Push the front cover downward using its upper end as a support to close the cover.

◆ Removal of the comb-shaped wiring cover

- FR-D820-1.5K-070 to 3.7K-165, FR-D840-2.2K-050, FR-D840-3.7K-081, FR-D820S-1.5K-070, FR-D820S-2.2K-100, FR-D810W-0.75K-042

(a)

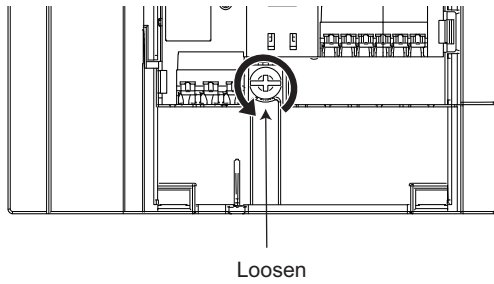

(b)

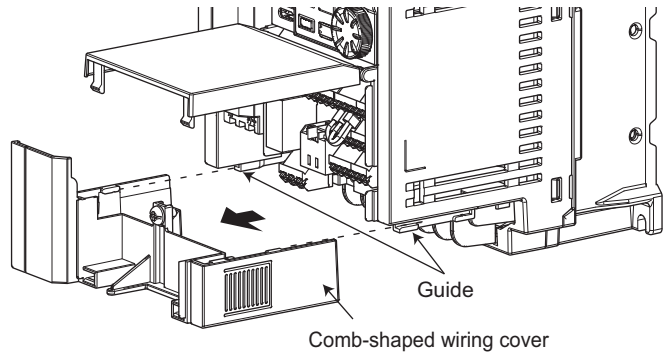

- (a) Loosen the mounting screw of the comb-shaped wiring cover.
(b) Pull out the cover along the guides in the direction shown by the arrow in the figure above.

- FR-D820-5.5K-238, FR-D820-7.5K-318, FR-D840-5.5K-120, FR-D840-7.5K-163

(a)

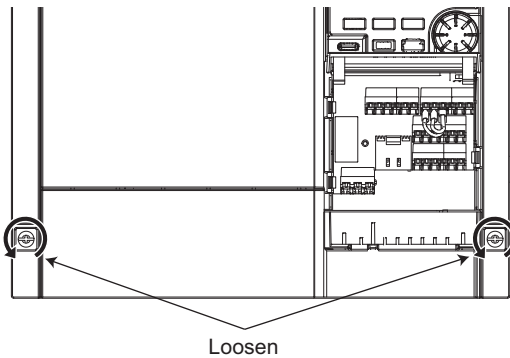

(b)

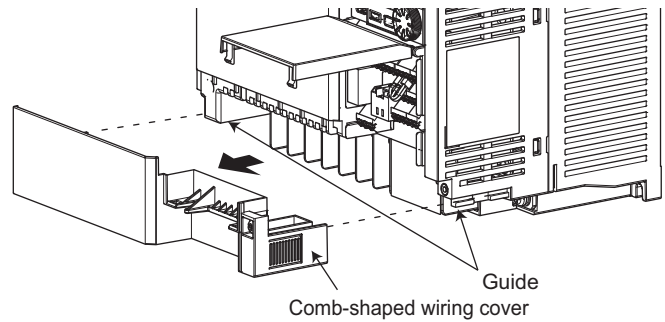

- (a) Loosen the mounting screws of the comb-shaped wiring cover.
(b) Pull out the cover along the guides in the direction shown by the arrow in the figure above.

- FR-D820-11K-450, FR-D820-15K-580, FR-D840-11K-230, FR-D840-15K-295

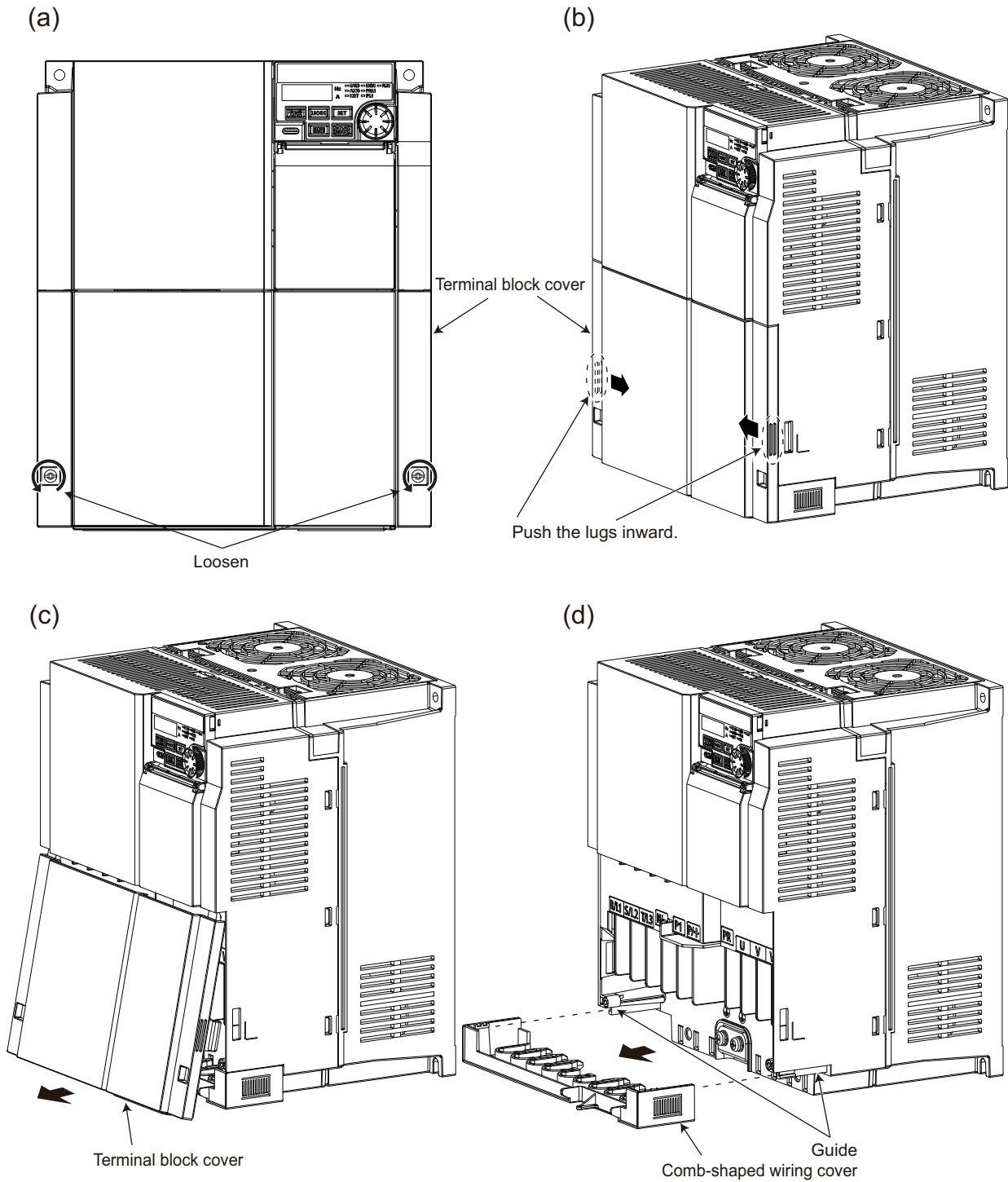

- Loosen the mounting screws of the terminal block cover.
- Push the lugs of the terminal block cover inward, as shown by the arrows in the figure above.
- Pull out the terminal block cover to remove it.
- Pull out the comb-shaped wiring cover along the guides in the direction shown by the arrow in the figure above.

◆ Reinstallation of the comb-shaped wiring cover

- FR-D820-1.5K-070 to 3.7K-165, FR-D840-2.2K-050, FR-D840-3.7K-081, FR-D820S-1.5K-070, FR-D820S-2.2K-100, FR-D810W-0.75K-042

(a)

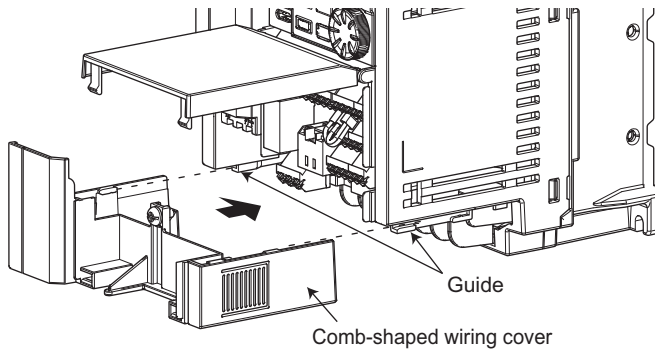

(b)

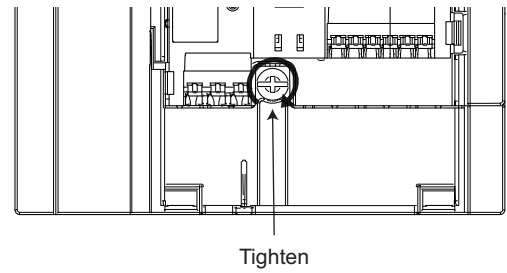

- (a) Fit the comb-shaped wiring cover to the inverter along the guides.
- (b) Tighten the mounting screw of the cover. (Tightening torque: 0.6 to 0.8 N·m)

- FR-D820-5.5K-238, FR-D820-7.5K-318, FR-D840-5.5K-120, FR-D840-7.5K-163

(a)

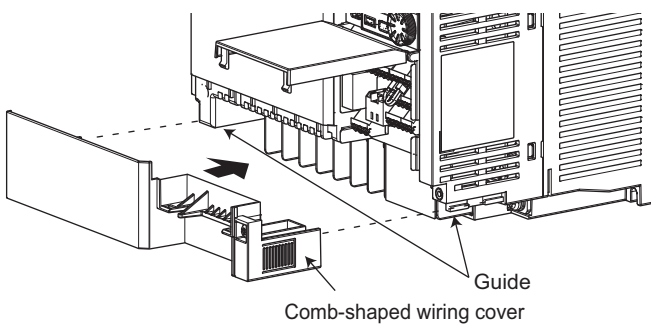

(b)

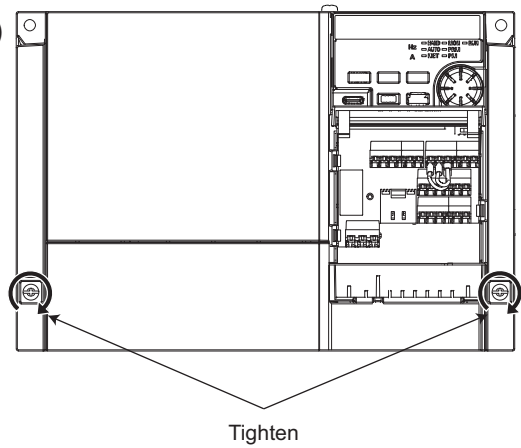

- (a) Fit the comb-shaped wiring cover to the inverter along the guides.
- (b) Tighten the mounting screws of the cover. (Tightening torque: 0.6 to 0.8 N·m)

- FR-D820-11K-450, FR-D820-15K-580, FR-D840-11K-230, FR-D840-15K-295

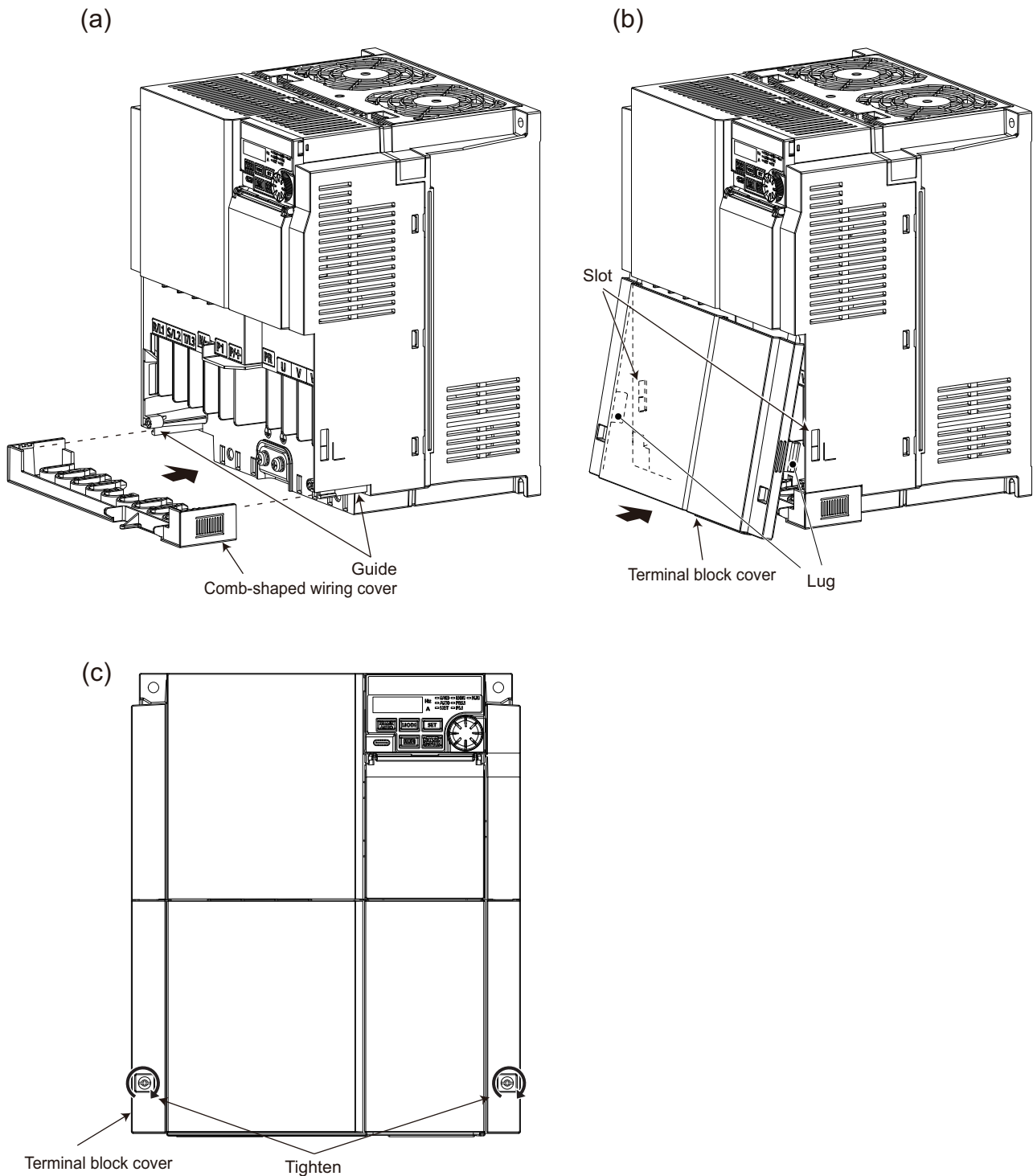

2.3 Installation of the inverter and enclosure design

2.3.1 Inverter installation environment

The following table lists the standard specifications of the inverter installation environment. Using the inverter in an environment that does not satisfy the conditions deteriorates the performance, shortens the life, and causes a failure. Refer to the following points, and take adequate measures.

◆ Standard environmental specifications of the inverter

Item	Description
Surrounding air temperature	-20°C to +60°C (non-freezing) SLD rating: The rated current must be reduced at a temperature above 40°C. ND rating: The rated current must be reduced at a temperature above 50°C. (For information on output current reduction, refer to page 39 .)
Ambient humidity	With circuit board coating (conforming to IEC 60721-3-3:1994 3C2/3S2): 95% RH or less (non-condensing), Without circuit board coating: 90% RH or less (non-condensing)
Storage temperature	-40°C to +70°C ^{*1}
Atmosphere	Indoors (free from corrosive gas, flammable gas, oil mist, dust and dirt)
Altitude	Maximum 3000 m ^{*2}
Vibration	5.9 m/s ² or less at 10 to 55 Hz (in either X, Y, or Z direction)

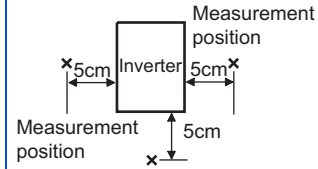

*1 Temperature applicable for a short time, for example, in transit.
 *2 For installation at an altitude above 1000 m, consider a 3% reduction in the rated current per 500 m increase in altitude.

◆ Temperature

The permissible range of surrounding air temperature is -20°C to +60°C. (The rated current must be reduced at a temperature above 50°C. Refer to [page 39](#).) Always operate the inverter within this temperature range. Operation outside this range will considerably shorten the service lives of the semiconductors, parts, capacitors and others. Take the following measures to keep the surrounding air temperature of the inverter within the specified range.

■ Measures against high temperature

- Use a forced ventilation system or similar cooling system. (Refer to [page 43](#).)
- Install the enclosure in an air-conditioned electric chamber.
- Block direct sunlight.
- Provide a shield or similar plate to avoid direct exposure to the radiated heat and wind of a heat source.
- Ventilate the area around the enclosure well.

■ Measures against low temperature

- Provide a space heater in the enclosure.
- Do not power OFF the inverter. (Keep the start signal of the inverter OFF.)

■ Sudden temperature changes

- Select an installation place where temperature does not change suddenly.
- Avoid installing the inverter near the air outlet of an air conditioner.
- If temperature changes are caused by opening/closing of a door, install the inverter away from the door.

NOTE

- For the amount of heat generated by the inverter unit, refer to [page 37](#).

◆ Humidity

Operate the inverter within the ambient air humidity of usually 45 to 90% (up to 95% with circuit board coating). Too high humidity will pose problems of reduced insulation and metal corrosion. On the other hand, too low humidity may cause a spatial electrical breakdown. The humidity conditions for the insulation distance defined in JEM 1103 standard "Insulation Distance from Control Equipment" is 45 to 85%.

■ Measures against high humidity

- Make the enclosure enclosed, and provide it with a hygroscopic agent.
- Provide dry air into the enclosure from outside.
- Provide a space heater in the enclosure.

■ Measures against low humidity

Air with proper humidity can be blown into the enclosure from outside. Also, when installing or inspecting the unit, discharge your body (static electricity) beforehand, and keep your body away from the parts and patterns.

■ Measures against condensation

Condensation may occur if frequent operation stops change the in-enclosure temperature suddenly or if the outside air temperature changes suddenly.

Condensation causes such faults as reduced insulation and corrosion.

- Take the measures against high humidity.
- Do not power OFF the inverter. (Keep the start signal of the inverter OFF.)

◆ Dust, dirt, oil mist

Dust and dirt will cause such faults as poor contacts, reduced insulation and cooling effect due to the moisture-absorbed accumulated dust and dirt, and in-enclosure temperature rise due to a clogged filter. In an atmosphere where conductive powder floats, dust and dirt will cause such faults as malfunction, deteriorated insulation and short circuit in a short time.

Since oil mist will cause similar conditions, it is necessary to take adequate measures.

■ Countermeasure

- Place the inverter in a totally enclosed enclosure.
Take measures if the in-enclosure temperature rises. (Refer to [page 43](#).)
- Purge air.
Pump clean air from outside to make the in-enclosure air pressure higher than the outside air pressure.

◆ Corrosive gas, salt damage

If the inverter is exposed to corrosive gas or to salt near a beach, the printed board patterns and parts will corrode or the relays and switches will result in poor contact.

In such places, take the measures given in the previous paragraph.

◆ Explosive, flammable gases

As the inverter is non-explosion proof, it must be contained in an explosion-proof enclosure. In places where explosion may be caused by explosive gas, dust or dirt, an enclosure cannot be used unless it structurally complies with the guidelines and has passed the specified tests. This makes the enclosure itself expensive (including the test charges). The best way is to avoid installation in such places and install the inverter in a non-hazardous place.

◆ High altitude

Use the inverter at an altitude of within 3000 m. For use at an altitude above 1000 m, consider a 3% reduction in the rated current per 500 m increase in altitude.

If it is used at a higher place, it is likely that thin air will reduce the cooling effect and low air pressure will deteriorate dielectric strength.

◆ Vibration, impact

The vibration resistance of the inverter is up to 5.9 m/s^2 at 10 to 55 Hz frequency and 1 mm amplitude for the directions of X, Y, Z axes. Subjecting the product to vibration and impacts over a long period of time may loosen the structure and cause poor contacts of connectors, even if those vibration and impacts are within the specified values.

Especially when impacts are applied repeatedly, caution must be taken because such impacts may break the installation feet.

■ Countermeasure

- Provide the enclosure with rubber vibration isolators.
- Strengthen the structure to prevent the enclosure from resonance.
- Install the enclosure away from the sources of the vibration.

2.3.2 Amount of heat generated by the inverter

◆ Installing the heat sink inside the enclosure

When the heat sink is installed inside the enclosure, the amount of heat generated by the inverter unit is shown in the following table.

Voltage	Inverter model	Amount of heat generated (W)	
		SLD	ND
Three-phase 200 V class	FR-D820-0.1K-008	15	10
	FR-D820-0.2K-014	24	15
	FR-D820-0.4K-025	39	23
	FR-D820-0.75K-042	56	38
	FR-D820-1.5K-070	87	59
	FR-D820-2.2K-100	142	78
	FR-D820-3.7K-165	234	149
	FR-D820-5.5K-238	277	196
	FR-D820-7.5K-318	339	262
	FR-D820-11K-450	418	326
	FR-D820-15K-580	537	420
Three-phase 400 V class	FR-D840-0.4K-012	30	18
	FR-D840-0.75K-022	45	27
	FR-D840-1.5K-037	61	43
	FR-D840-2.2K-050	98	59
	FR-D840-3.7K-081	155	103
	FR-D840-5.5K-120	193	135
	FR-D840-7.5K-163	260	168
	FR-D840-11K-230	294	218
	FR-D840-15K-295	392	284
Single-phase 200 V class	FR-D820S-0.1K-008	—	11
	FR-D820S-0.2K-014	—	16
	FR-D820S-0.4K-025	—	28
	FR-D820S-0.75K-042	—	45
	FR-D820S-1.5K-070	—	70
	FR-D820S-2.2K-100	—	98
Single-phase 100 V class	FR-D810W-0.1K-008	—	11
	FR-D810W-0.2K-014	—	17
	FR-D810W-0.4K-025	—	27
	FR-D810W-0.75K-042	—	43

NOTE

- The figures indicate the amount of heat generated when the output current is the rated current, power supply voltage is 110 V (100 V class), 220 V (200 V class), or 440 V (400 V class), and the carrier frequency is 1 kHz.

◆ Installing the heat sink outside the enclosure

For certain models of FR-D800 inverters, only the outline dimension data of panel through attachments is available. The outline dimension data can be downloaded from the Mitsubishi Electric FA Japanese Website.

Select FR-D800 as a search condition.

<https://www.MitsubishiElectric.co.jp/fa/download/cad/search.page?mode=cad&kisyu=inv>

For details, refer to the Technical News (MF-K-201).

2.3.3 Output current reduction when the surrounding air temperature is between 50°C and 60°C for ND rating and between 40°C and 60°C for SLD rating

When the surrounding air temperature is between 50°C and 60°C, reduce the rated output current as shown in the following table.

- FR-D820-0.1K-008 to FR-D820-0.75K-042, FR-D820S-0.1K-008 to FR-D820S-0.75K-042, FR-D810W-0.1K-008 to FR-D810W-0.75K-042

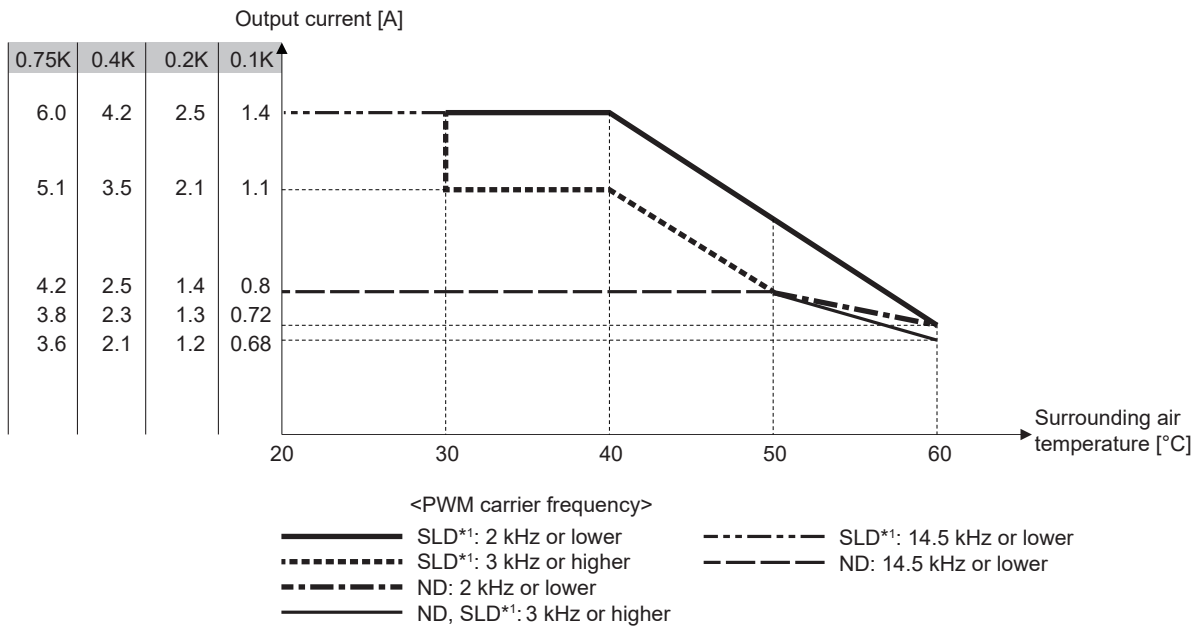

*1 SLD rating is available for the three-phase 200 V class only.

- FR-D820-1.5K-070 to FR-D820-3.7K-165, FR-D820S-1.5K-070 to FR-D820S-2.2K-100

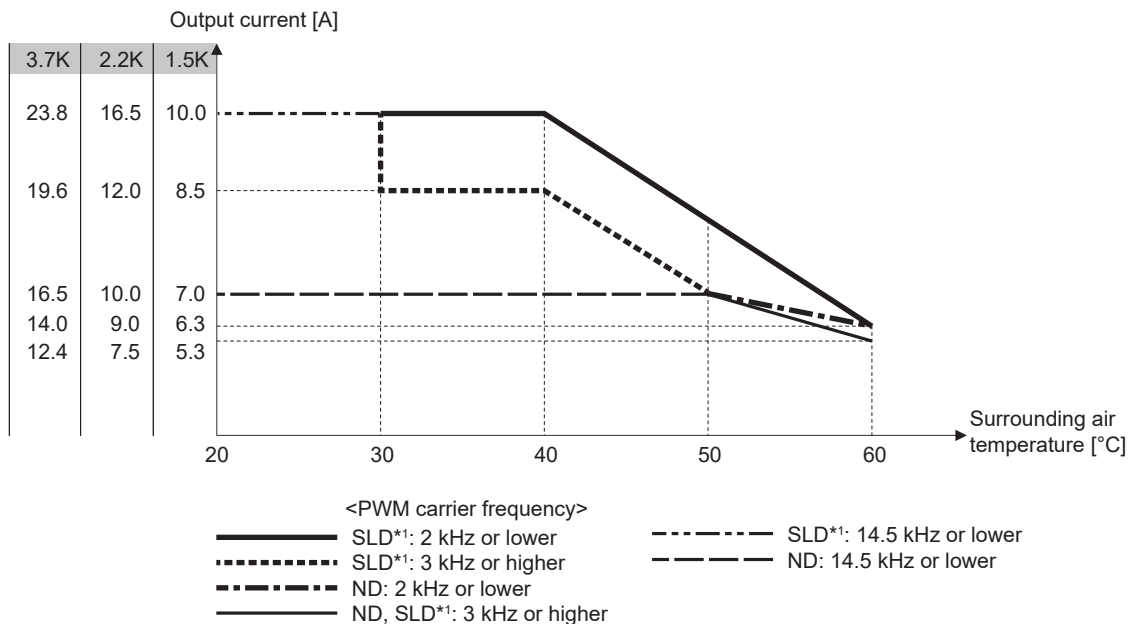

*1 SLD rating is available for the three-phase 200 V class only.

- FR-D840-0.4K-012 to FR-D840-3.7K-081

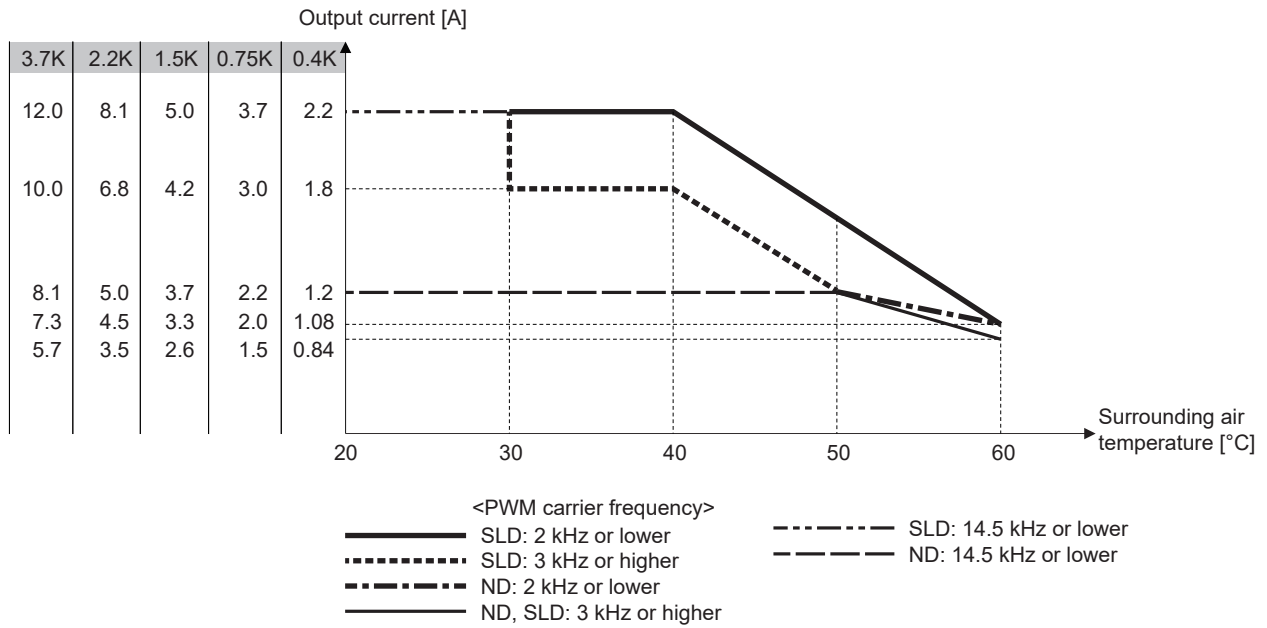

- FR-D820-5.5K-238, FR-D820-7.5K-318, FR-D840-5.5K-020, FR-D840-7.5K-163

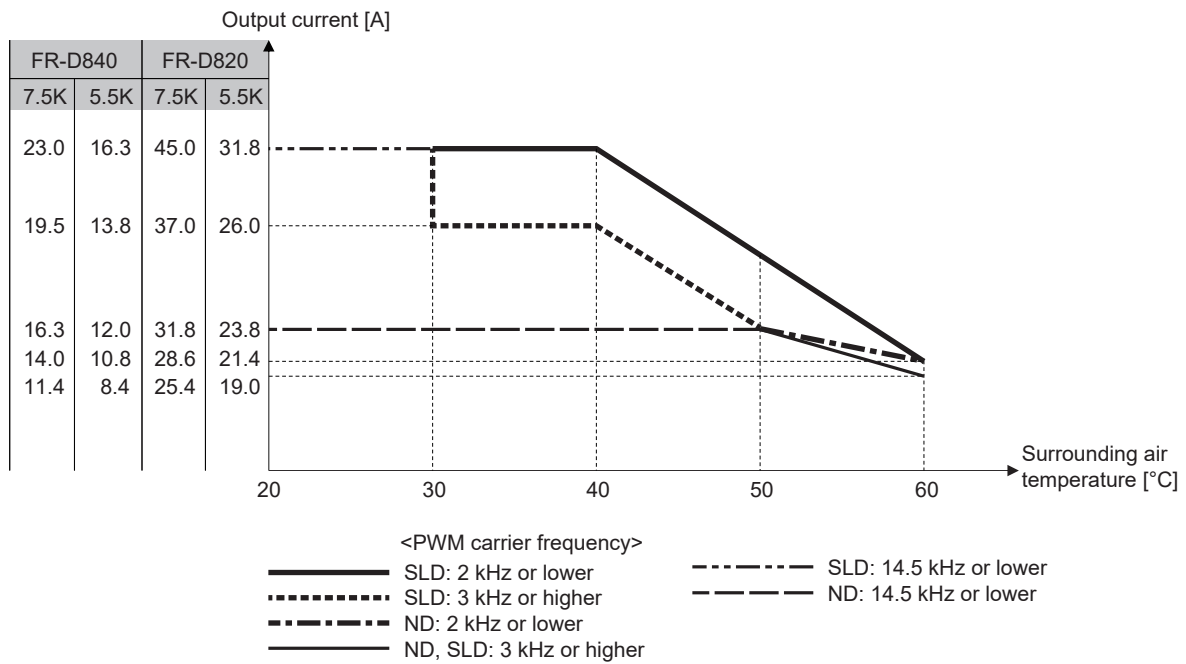

- FR-D820-11K-450, FR-D820-15K-580, FR-D840-11K-230, FR-D840-15K-295

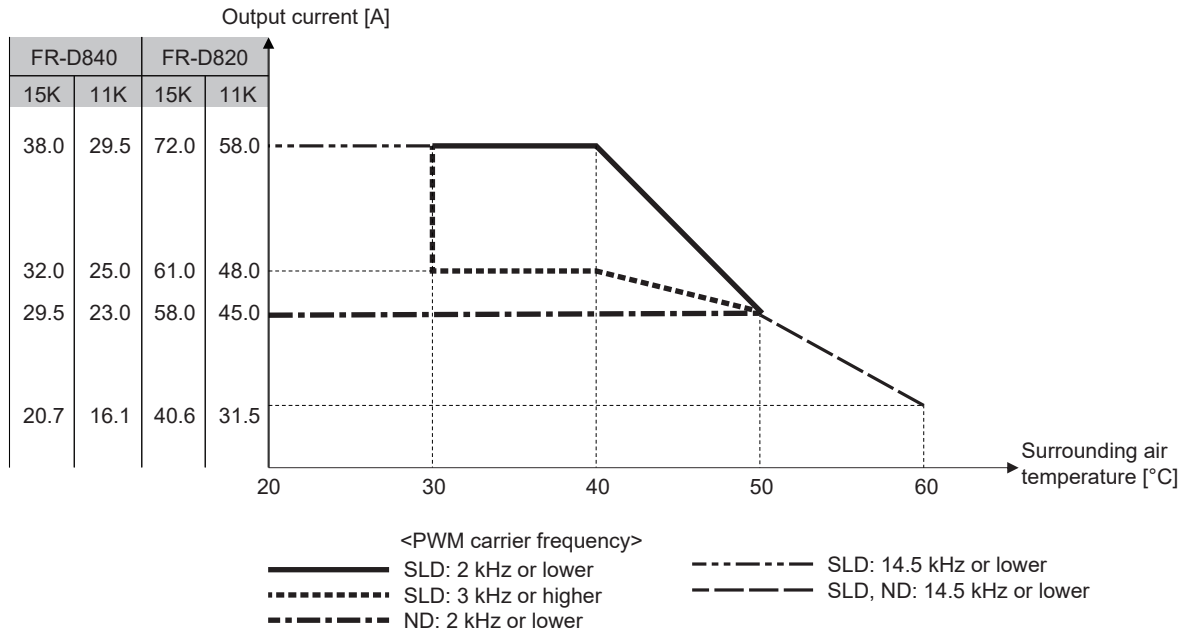

NOTE

- Do not use the inverter in an environment with the surrounding air temperature exceeding 60°C.
- [Calculation example] When the FR-D820-2.2K-100 inverter is used with the ND rating in an environment with the surrounding air temperature of 55°C and the carrier frequency of 1 kHz.

Rated current at surrounding air temperature 55°C

$$= \frac{\text{Rated current [A] at 60 [°C]} - \text{rated current [A] at 50 [°C]}}{60 [°C] - 50 [°C]} \times (60 [°C] - \text{surrounding air temperature [°C]}) + \text{rated current [A] at 50 [°C]}$$

$$= \frac{9.0 [A] - 10.0 [A]}{60 [°C] - 50 [°C]} \times (60 [°C] - 55 [°C]) + 10.0 [A]$$

$$= 9.5 [A]$$

2.3.4 Standby power consumption by the inverter

The following table shows the standby power consumption during a stop.

Voltage	Inverter model	Standby power consumption (W)	
		Light duty	Heavy duty
Three-phase 200 V class	FR-D820-0.1K-008	4.5	10
	FR-D820-0.2K-014	4.5	10
	FR-D820-0.4K-025	4.5	10
	FR-D820-0.75K-042	4.5	10
	FR-D820-1.5K-070	5.5	10.5
	FR-D820-2.2K-100	5.5	13
	FR-D820-3.7K-165	5.5	15
	FR-D820-5.5K-238	10	22
	FR-D820-7.5K-318	10	22
	FR-D820-11K-450	12	27
FR-D820-15K-580	12	27	
Three-phase 400 V class	FR-D840-0.4K-012	7.5	13
	FR-D840-0.75K-022	7.5	13
	FR-D840-1.5K-037	7.5	13
	FR-D840-2.2K-050	8.5	15
	FR-D840-3.7K-081	8.5	17
	FR-D840-5.5K-120	12	22
	FR-D840-7.5K-163	12	22
	FR-D840-11K-230	12	24
FR-D840-15K-295	12	24	
Single-phase 200 V class	FR-D820S-0.1K-008	4.5	10
	FR-D820S-0.2K-014	4.5	10
	FR-D820S-0.4K-025	4.5	10
	FR-D820S-0.75K-042	4.5	10
	FR-D820S-1.5K-070	5.5	10.5
	FR-D820S-2.2K-100	5.5	13
Single-phase 100 V class	FR-D810W-0.1K-008	5.5	10.5
	FR-D810W-0.2K-014	5.5	10.5
	FR-D810W-0.4K-025	5.5	10.5
	FR-D810W-0.75K-042	5.5	10.5

NOTE

- Operation of the inverter alone is assumed for the standby power consumption with the light load.
- Operation of the FR-PU07 and fan is assumed for the standby power consumption with the heavy load.

2.3.5 Cooling system types for inverter enclosure

From the enclosure that contains the inverter, the heat of the inverter and other equipment (transformers, lamps, resistors, etc.) and the incoming heat such as direct sunlight must be dissipated to keep the in-enclosure temperature lower than the permissible temperatures of the in-enclosure equipment including the inverter.

The cooling systems are classified as follows in terms of the cooling calculation method.

- Cooling by natural heat dissipation from the enclosure surface (totally enclosed type)
- Cooling by heat sink (aluminum fin, etc.)
- Cooling by ventilation (forced ventilation type, pipe ventilation type)
- Cooling by heat exchanger or cooler (heat pipe, cooler, etc.)

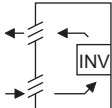
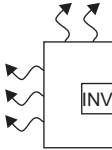
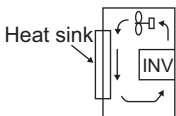
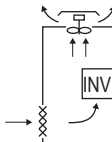
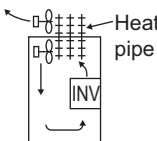
Cooling system		Enclosure structure	Comment
Natural	Natural ventilation (enclosed type / open type)		This system is low in cost and generally used, but the enclosure size increases as the inverter capacity increases. This system is for relatively small capacities.
	Natural ventilation (totally enclosed type)		Being a totally enclosed type, this system is the most appropriate for hostile environment having dust, dirt, oil mist, etc. The enclosure size increases depending on the inverter capacity.
Forced air	Heat sink cooling		This system has restrictions on the heat sink mounting position and area. This system is for relatively small capacities.
	Forced ventilation		This system is for general indoor installation. This is appropriate for enclosure downsizing and cost reduction, and often used.
	Heat pipe		This system is a totally enclosed type, and is appropriate for enclosure downsizing.

2.3.6 Inverter installation

◆ Inverter placement

FR-D820-0.1K-008 to 0.75K-042
 FR-D840-0.4K-012 to 1.5K-037
 FR-D820S-0.1K-008 to 0.4K-025
 FR-D810W-0.1K-008 to 0.4K-025

FR-D820-1.5K-070 to 7.5K-318
 FR-D840-2.2K-050 to 7.5K-163
 FR-D820S-0.75K-042 to 2.2K-100
 FR-D810W-0.75K-042

FR-D820-11K-450, FR-D820-15K-580
 FR-D840-11K-230, FR-D840-15K-295

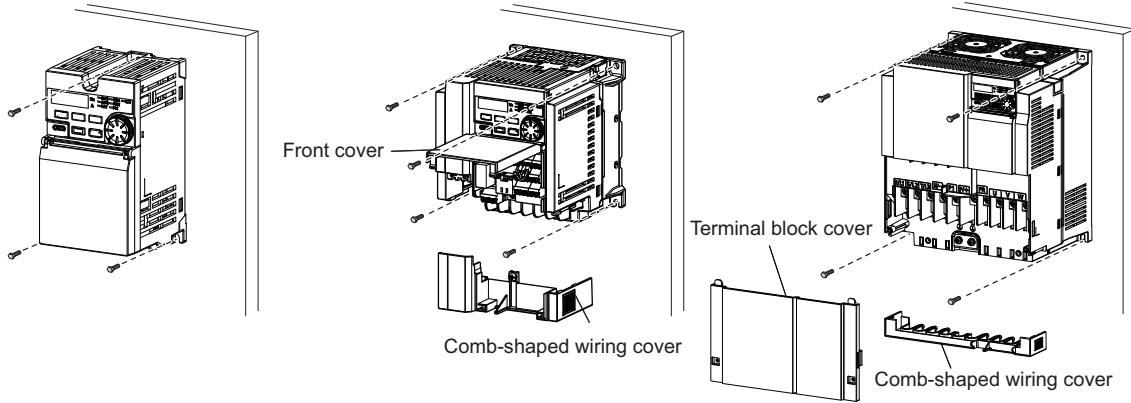

- For the FR-D820-1.5K-070 to 7.5K-318, FR-D840-2.2K-050 to 7.5K-163, FR-D820S-0.75K-042 to 2.2K-100, and FR-D810W-0.75K-042, remove the comb-shaped wiring cover before installing the inverter to the enclosure surface with the mounting screws.
- Install the inverter on a strong surface securely with screws.
- Leave enough clearances and take cooling measures.
- Avoid places where the inverter is subjected to direct sunlight, high temperature and high humidity.
- Install the inverter on a nonflammable wall surface.
- When encasing multiple inverters in an enclosure, install them in parallel as a cooling measure.
- For heat dissipation and maintenance, keep clearance between the inverter and the other devices or enclosure surface. The space below the inverter is required for wiring, and the space above the inverter is required for heat dissipation.

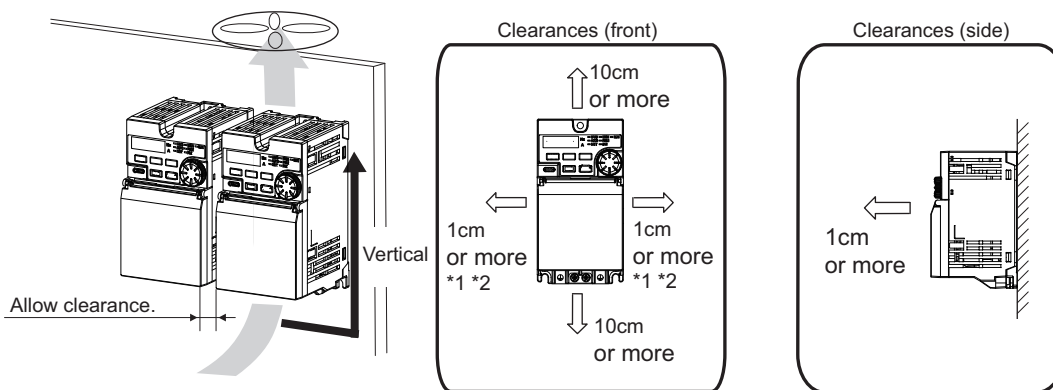

*1 When using the inverters at the surrounding air temperature of 40°C or less, the inverters can be installed side-by-side (closely attached with 0 cm clearance).

*2 5 cm or more for the FR-D820-5.5K-238 or higher and the FR-D840-5.5K-120 or higher.

- When designing or building an enclosure for the inverter, carefully consider influencing factors such as heat generation of the contained devices and the operating environment.

◆ Installation orientation of the inverter

Install the inverter on a wall as specified. Do not mount it horizontally or in any other way.

◆ Above the inverter

Heat is blown up from inside the inverter by the small fan built in the unit. Any equipment placed above the inverter should be heat resistant.

◆ Arrangement of multiple inverters

When multiple inverters are placed in the same enclosure, arrange them horizontally as shown in the figure (a). When it is inevitable to arrange them vertically to minimize space, take such measures as to provide guides between the inverters since heat generated in the inverters in bottom row can increase the temperatures in the inverters in top row, causing inverter failures. When installing multiple inverters, fully take measures to prevent the surrounding air temperature of the inverter from being higher than the permissible value by providing ventilation or increasing the enclosure size.

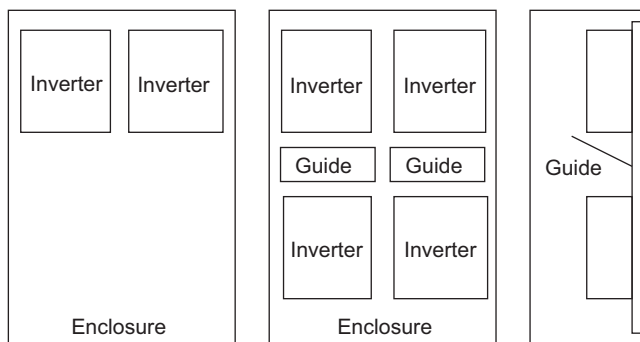

(a) Horizontal arrangement

(b) Vertical arrangement

Arrangement of multiple inverters

◆ Arrangement of the ventilation fan and inverter

Heat generated in the inverter is blown up from the bottom of the unit as warm air by the cooling fan. When installing a ventilation fan for that heat, determine the place of ventilation fan installation after fully considering an air flow. (Air passes through areas of low resistance. Make an airway and airflow plates to expose the inverter to cool air.)

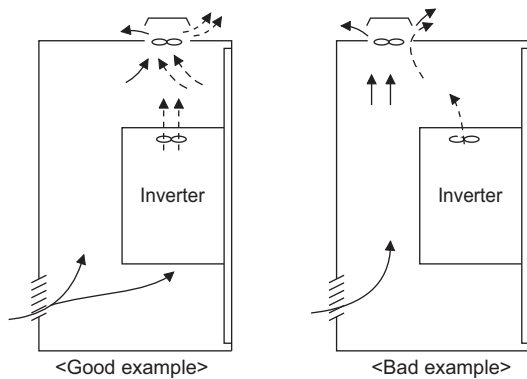

Arrangement of the ventilation fan and inverter

2.4 Terminal connection diagrams

◆ Sink logic

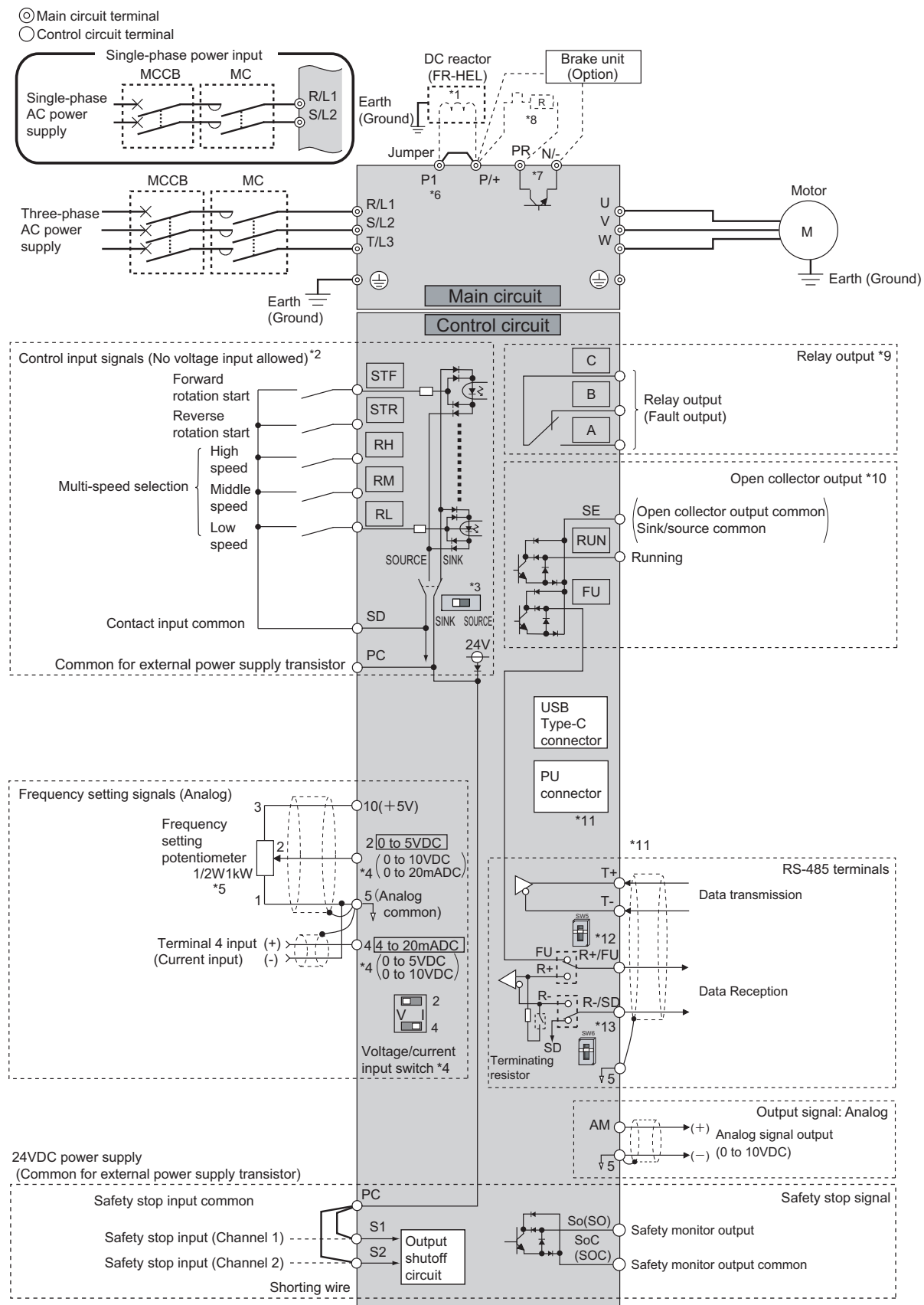

- *1 Remove the jumper between P1 and P/+ to connect the DC reactor. (Single-phase 100 V power input model is not compatible with the DC reactor.)
- *2 The function of these terminals can be changed using the Input terminal function selection (**Pr.178 to Pr.182**). (Refer to the Instruction Manual (Function).)
- *3 The initial setting varies depending on the specification.
- *4 Terminal input specifications can be changed by analog input specification switchover (**Pr.73, Pr.267**). To input voltage, set the voltage/current input switch to "V". To input current, set the switch to "I". The initial setting varies depending on the specification. (Refer to the Instruction Manual (Function).)
- *5 It is recommended to use 2 W 1 k Ω when the frequency setting signal is changed frequently.
- *6 Terminal P1 is not available for the single-phase 100 V power input models.
- *7 A brake transistor is not built in to the FR-D820-0.1K-008, FR-D820-0.2K-014, FR-D820S-0.1K-008, FR-D820S-0.2K-014, FR-D810W-0.1K-008, and FR-D810W-0.2K-014.
- *8 Brake resistor (FR-ABR, MRS, MYS)
Install a thermal relay to prevent overheating and damage of brake resistors. (A brake resistor cannot be connected to the FR-D820-0.1K-008, FR-D820-0.2K-014, FR-D820S-0.1K-008, FR-D820S-0.2K-014, FR-D810W-0.1K-008, and FR-D810W-0.2K-014.) (Refer to [page 78](#).)
- *9 The function of these terminals can be changed using the **Pr.192 ABC terminal function selection**.
- *10 The function of these terminals can be changed using the Output terminal function selection (**Pr.190 or Pr.191**). (Refer to the Instruction Manual (Function).)
- *11 The communication circuit is shared between the PU connector and the RS-485 terminals. The PU connector and the RS-485 terminals cannot be used simultaneously. Use either the connector or the terminals, and do not wire the other. RS-485 communication via the PU connector is enabled initially.
- *12 Initially set to FU. Switch between R+ and FU. Both cannot be selected at the same time.
- *13 Initially set to SD. Switch between R- and SD. Both cannot be selected at the same time.

NOTE

- To prevent a malfunction due to noise, keep the signal cables 10 cm or more away from the power cables. Also, keep the cables of the main circuit for input and output separated. For the cables connected to the control circuit terminals, connect their shields to the enclosure earth (ground). If a problem such as a malfunction caused by noise flowing from the earthing (grounding) occurs, do not connect the shielded cables to the enclosure earth (ground). Instead the single-point earthing (grounding), where shielded cables are to be connected to each common terminal, is recommended.
- After wiring, wire offcuts must not be left in the inverter.
- Wire offcuts can cause a fault, failure or malfunction. Always keep the inverter clean.
- When drilling mounting holes in an enclosure etc., take caution not to allow chips and other foreign matter to enter the inverter.
- Set the switches of the voltage/current input switch assembly correctly. Incorrect setting may cause a fault, failure or malfunction.
- The output of the single-phase power input model is three-phase 200 V.

◆ Source logic

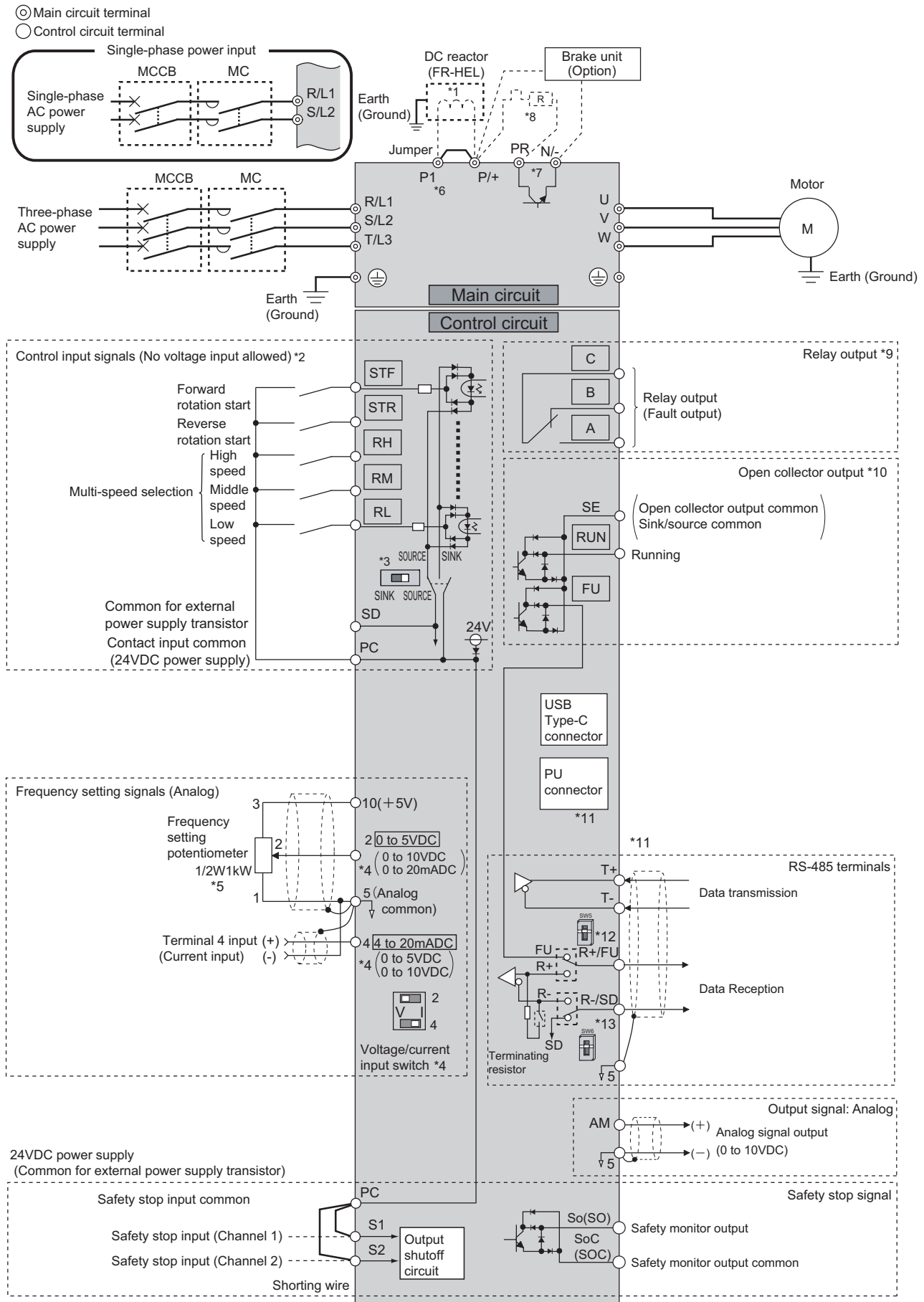

- *1 Remove the jumper between P1 and P/+ to connect the DC reactor. (Single-phase 100 V power input model is not compatible with the DC reactor.)
- *2 The function of these terminals can be changed using the Input terminal function selection (**Pr.178 to Pr.182**). (Refer to the Instruction Manual (Function).)
- *3 The initial setting varies depending on the specification.
- *4 Terminal input specifications can be changed by analog input specification switchover (**Pr.73, Pr.267**). To input voltage, set the voltage/current input switch to "V". To input current, set the switch to "I". The initial setting varies depending on the specification. (Refer to the Instruction Manual (Function).)
- *5 It is recommended to use 2 W 1 k Ω when the frequency setting signal is changed frequently.
- *6 Terminal P1 is not available for the single-phase 100 V power input models.
- *7 A brake transistor is not built in to the FR-D820-0.1K-008, FR-D820-0.2K-014, FR-D820S-0.1K-008, FR-D820S-0.2K-014, FR-D810W-0.1K-008, and FR-D810W-0.2K-014.
- *8 Brake resistor (FR-ABR, MRS, MYS)
Install a thermal relay to prevent overheating and damage of brake resistors. (A brake resistor cannot be connected to the FR-D820-0.1K-008, FR-D820-0.2K-014, FR-D820S-0.1K-008, FR-D820S-0.2K-014, FR-D810W-0.1K-008, and FR-D810W-0.2K-014.) (Refer to [page 78](#).)
- *9 The function of these terminals can be changed using the **Pr.192 ABC terminal function selection**.
- *10 The function of these terminals can be changed using the Output terminal function selection (**Pr.190 or Pr.191**). (Refer to the Instruction Manual (Function).)
- *11 The communication circuit is shared between the PU connector and the RS-485 terminals. The PU connector and the RS-485 terminals cannot be used simultaneously. Use either the connector or the terminals, and do not wire the other. RS-485 communication via the PU connector is enabled initially.
- *12 Initially set to FU. Switch between R+ and FU. Both cannot be selected at the same time.
- *13 Initially set to SD. Switch between R- and SD. Both cannot be selected at the same time.

NOTE

- To prevent a malfunction due to noise, keep the signal cables 10 cm or more away from the power cables. Also, keep the cables of the main circuit for input and output separated. For the cables connected to the control circuit terminals, connect their shields to the enclosure earth (ground). If a problem such as a malfunction caused by noise flowing from the earthing (grounding) occurs, do not connect the shielded cables to the enclosure earth (ground). Instead the single-point earthing (grounding), where shielded cables are to be connected to each common terminal, is recommended.
- After wiring, wire offcuts must not be left in the inverter.
- Wire offcuts can cause a fault, failure or malfunction. Always keep the inverter clean.
- When drilling mounting holes in an enclosure etc., take caution not to allow chips and other foreign matter to enter the inverter.
- Set the switches of the voltage/current input switch assembly correctly. Incorrect setting may cause a fault, failure or malfunction.
- The output of the single-phase power input model is three-phase 200 V.

2.5 Main circuit terminals

2.5.1 Details on the main circuit terminals

Terminal symbol	Terminal name	Terminal function description	Refer to page
R/L1, S/L2, T/L3 ^{*1}	AC power input	Connect these terminals to the commercial power supply.	—
U, V, W	Inverter output	Connect these terminals to a three-phase squirrel cage motor or a PM motor.	—
P/+, PR	Brake resistor connection	Connect an optional brake resistor (FR-ABR, MRS, or MYS model) across terminals P/+ and PR. (A brake resistor cannot be connected to the FR-D820-0.1K-008, FR-D820-0.2K-014, FR-D820S-0.1K-008, FR-D820S-0.2K-014, FR-D810W-0.1K-008, and FR-D810W-0.2K-014.)	78
P/+, N/-	Brake unit connection	Connect the brake unit (FR-BU2, FR-BU, or BU) or the multifunction regeneration converter (FR-XC in power regeneration mode 2) to these terminals.	82
P/+, P1 ^{*2}	DC reactor connection	Remove the jumper across terminals P/+ and P1, and connect a DC reactor. (A DC reactor cannot be connected to the single-phase 100 V power input models.) ^{*3} When a DC reactor is not connected, the jumper across terminals P/+ and P1 should not be removed.	87
	Earth (ground)	For earthing (grounding) the inverter chassis. Be sure to earth (ground) the inverter.	58

- *1 Terminal T/L3 is not available for the single-phase power input model.
- *2 Terminal P1 is not available for the single-phase 100 V power input models.
- *3 Remove the jumper with a tool such as tweezers.

2.5.2 Main circuit terminal layout and wiring to power supply and motor

◆ Three-phase 200/400 V class

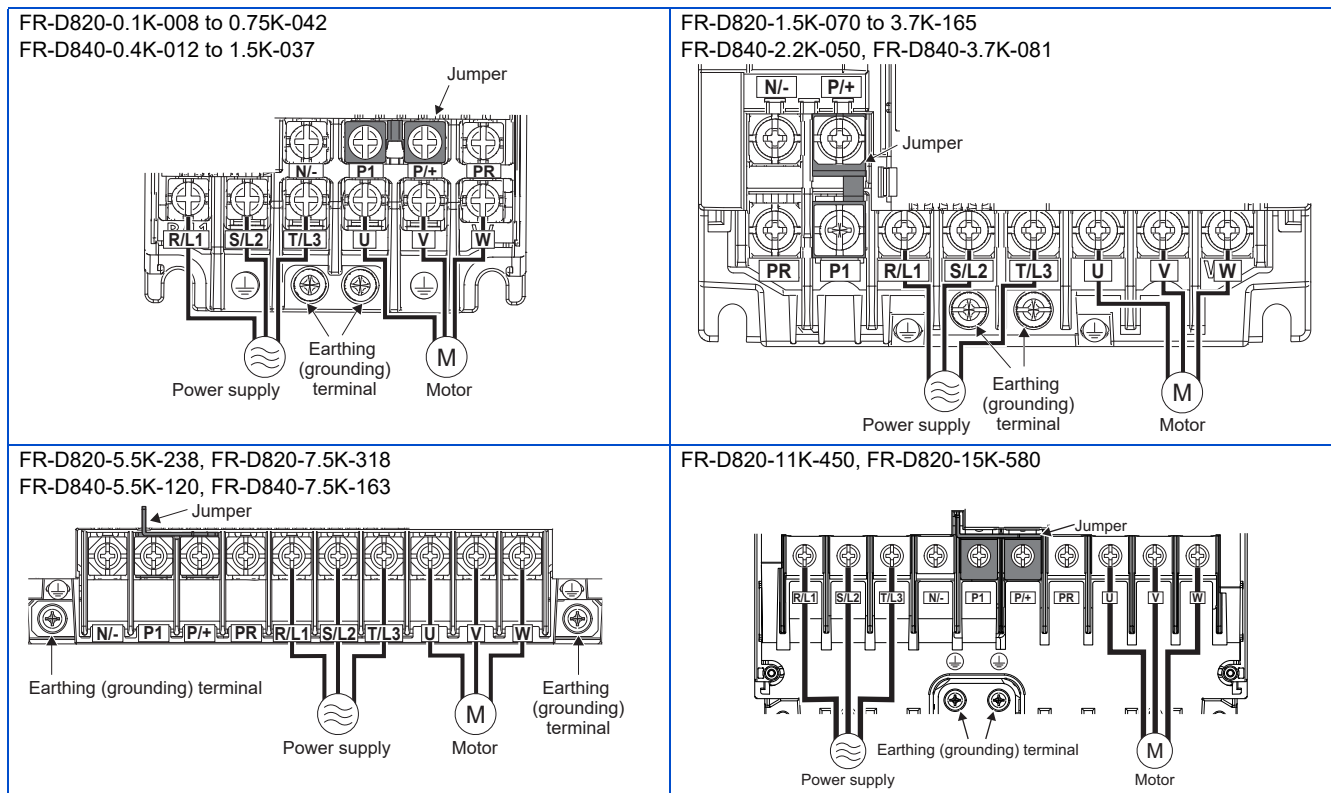

FR-D840-11K-230, FR-D840-15K-295

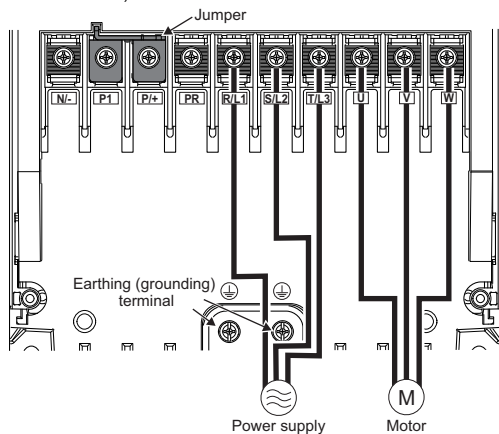

◆ Single-phase 200 V class

FR-D820S-0.1K-008 to 0.75K-042

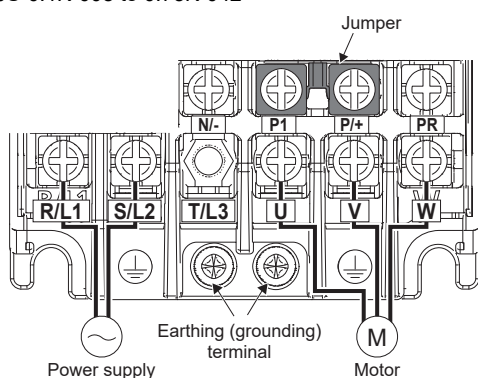

FR-D820S-1.5K-070, FR-D820S-2.2K-100

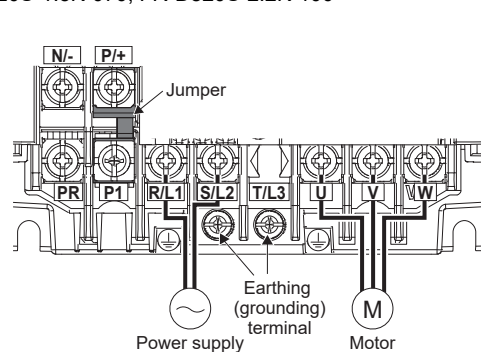

◆ Single-phase 100 V class

FR-D810W-0.1K-008 to 0.4K-025

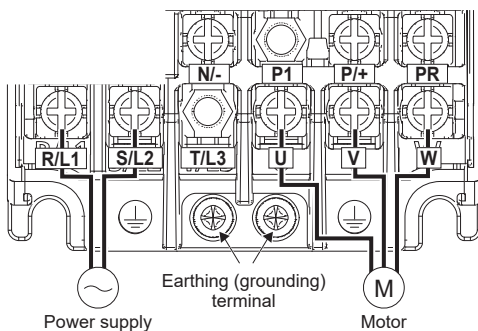

FR-D810W-0.75K-042

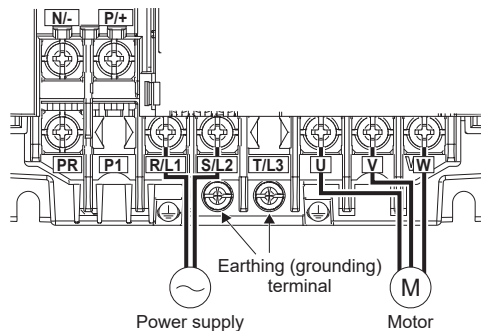

NOTE

- Make sure the power cables are connected to the R/L1, S/L2, and T/L3. (Phase need not be matched.) Never connect the power cable to the U, V, and W of the inverter. Doing so will damage the inverter.
- Connect the motor to U, V, and W. (The phases must be matched.)

■ Handling of the comb-shaped wiring cover

Cut off lugs of the comb-shaped wiring cover as required using tools such as needle-nose pliers. The lugs must be cut off for the FR-D820-1.5K-070 to 15K-580, FR-D840-2.2K-050 to 7.5K-163, FR-D820S-1.5K-070, FR-D820S-2.2K-100, and FR-D810W-0.75K-042.

NOTE

- Cut off the same number of lugs as wires.

If parts where no wire is put through have been cut off (10 mm or more), protective structure (IEC 60529) becomes an open type (IP00).

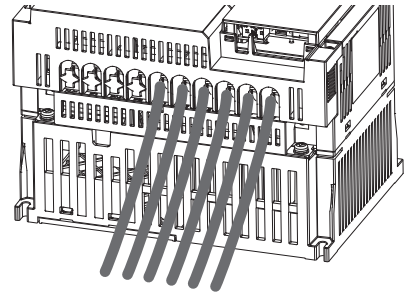
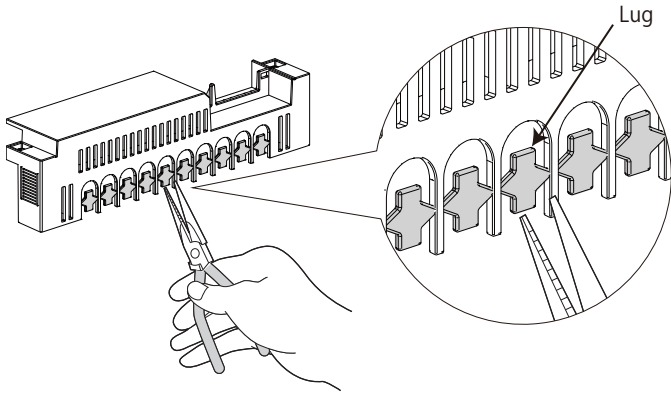

2.5.3 Applicable cables and wiring length

◆ For the ND rating

- Three-phase 200 V class (220 V input power supply, without a power factor improving AC or DC reactor)

Applicable inverter model FR-D820-□	Terminal screw size ^{*4}	Tightening torque N·m	Crimp terminal		Cable gauge									
					HIV cables, etc. (mm ²) ^{*1}				AWG/MCM ^{*2}		PVC cables, etc. (mm ²) ^{*3}			
			R/L1, S/L2, T/L3	U, V, W	R/L1, S/L2, T/L3	U, V, W	P/+, P1	Earthing (grounding) cable	R/L1, S/L2, T/L3	U, V, W	R/L1, S/L2, T/L3	U, V, W	Earthing (grounding) cable	
0.1K-008 to 0.75K-042	M3.5	1.2	2-3.5	2-3.5	2	2	2	2		14	14	2.5	2.5	2.5
1.5K-070, 2.2K-100	M4 (M3.5)	1.5	2-4	2-4	2	2	2	2		14	14	2.5	2.5	2.5
3.7K-165	M4 (M3.5)	1.5	5.5-4	5.5-4	3.5	3.5	3.5	3.5		12	12	4	4	4
5.5K-238	M5	2.5	5.5-5	5.5-5	5.5	5.5	5.5	5.5		10	10	6	6	6
7.5K-318	M5	2.5	14-5	8-5	14	8	8	5.5		6	8	16	10	6
11K-450	M5	2.5	14-5	14-5	14	14	14	8		6	6	16	16	16
15K-580	M6 (M5)	4.4	22-6	22-6	22	22	22	14		4	4	25	25	16

- Three-phase 200 V class (220 V input power supply, with a power factor improving AC or DC reactor)

Applicable inverter model FR-D820-□	Terminal screw size ^{*4}	Tightening torque N·m	Crimp terminal		Cable gauge									
					HIV cables, etc. (mm ²) ^{*1}				AWG/MCM ^{*2}		PVC cables, etc. (mm ²) ^{*3}			
			R/L1, S/L2, T/L3	U, V, W	R/L1, S/L2, T/L3	U, V, W	P/+, P1	Earthing (grounding) cable	R/L1, S/L2, T/L3	U, V, W	R/L1, S/L2, T/L3	U, V, W	Earthing (grounding) cable	
0.1K-008 to 0.75K-042	M3.5	1.2	2-3.5	2-3.5	2	2	2	2		14	14	2.5	2.5	2.5
1.5K-070, 2.2K-100	M4 (M3.5)	1.5	2-4	2-4	2	2	2	2		14	14	2.5	2.5	2.5
3.7K-165	M4 (M3.5)	1.5	5.5-4	5.5-4	3.5	3.5	3.5	3.5		12	12	4	4	4
5.5K-238	M5	2.5	5.5-5	5.5-5	5.5	5.5	5.5	5.5		10	10	6	6	6
7.5K-318	M5	2.5	8-5	8-5	8	8	8	5.5		8	8	10	10	6
11K-450	M5	2.5	14-5	14-5	14	14	14	8		6	6	16	16	16
15K-580	M6 (M5)	4.4	22-6	22-6	22	22	22	14		4	4	25	25	16

- Three-phase 400 V class (440 V input power supply, without a power factor improving AC or DC reactor)

Applicable inverter model FR-D840-□	Terminal screw size ^{*4}	Tightening torque N·m	Crimp terminal		Cable gauge									
					HIV cables, etc. (mm ²) ^{*1}				AWG/MCM ^{*2}		PVC cables, etc. (mm ²) ^{*3}			
			R/L1, S/L2, T/L3	U, V, W	R/L1, S/L2, T/L3	U, V, W	P/+, P1	Earthing (grounding) cable	R/L1, S/L2, T/L3	U, V, W	R/L1, S/L2, T/L3	U, V, W	Earthing (grounding) cable	
0.4K-012 to 1.5K-037	M3.5	1.2	2-3.5	2-3.5	2	2	2	2		14	14	2.5	2.5	2.5
2.2K-050, 3.7K-081	M4 (M3.5)	1.5	2-4	2-4	2	2	2	2		14	14	2.5	2.5	2.5
5.5K-120	M4	1.5	5.5-4	2-4	3.5	2	3.5	3.5		12	14	4	2.5	4
7.5K-163	M4	1.5	5.5-4	5.5-4	3.5	3.5	3.5	3.5		12	12	4	4	4
11K-230	M4	1.5	5.5-4	5.5-4	5.5	5.5	5.5	5.5		10	10	6	6	10
15K-295	M5	2.5	8-5	8-5	8	8	8	5.5		8	8	10	10	10

- Three-phase 400 V class (440 V input power supply, with a power factor improving AC or DC reactor)

Applicable inverter model FR-D840-□	Terminal screw size ^{*4}	Tightening torque N·m	Crimp terminal		Cable gauge									
					HIV cables, etc. (mm ²) ^{*1}				AWG/MCM ^{*2}		PVC cables, etc. (mm ²) ^{*3}			
			R/L1, S/L2, T/L3	U, V, W	R/L1, S/L2, T/L3	U, V, W	P/+, P1	Earthing (grounding) cable	R/L1, S/L2, T/L3	U, V, W	R/L1, S/L2, T/L3	U, V, W	Earthing (grounding) cable	
0.4K-012 to 1.5K-037	M3.5	1.2	2-3.5	2-3.5	2	2	2	2		14	14	2.5	2.5	2.5
2.2K-050, 3.7K-081	M4 (M3.5)	1.5	2-4	2-4	2	2	2	2		14	14	2.5	2.5	2.5
5.5K-120	M4	1.5	2-4	2-4	2	2	3.5	2		14	14	2.5	2.5	2.5

Applicable inverter model FR-D840-□	Terminal screw size ^{*4}	Tightening torque N·m	Crimp terminal		Cable gauge									
					HIV cables, etc. (mm ²) ^{*1}				AWG/MCM ^{*2}		PVC cables, etc. (mm ²) ^{*3}			
			R/L1, S/L2, T/L3	U, V, W	R/L1, S/L2, T/L3	U, V, W	P/+, P1	Earthing (grounding) cable	R/L1, S/L2, T/L3	U, V, W	R/L1, S/L2, T/L3	U, V, W	Earthing (grounding) cable	
7.5K-163	M4	1.5	5.5-4	5.5-4	3.5	3.5	3.5	3.5	12	12	4	4	4	
11K-230	M4	1.5	5.5-4	5.5-4	5.5	5.5	5.5	5.5	10	10	6	6	6	
15K-295	M5	2.5	8-5	8-5	8	8	8	5.5	8	8	10	10	10	

- Single-phase 200 V class (220 V input power supply, without a power factor improving AC or DC reactor)

Applicable inverter model FR-D820S-□	Terminal screw size ^{*4}	Tightening torque N·m	Crimp terminal		Cable gauge									
					HIV cables, etc. (mm ²) ^{*1}				AWG/MCM ^{*2}		PVC cables, etc. (mm ²) ^{*3}			
			R/L1, S/L2	U, V, W	R/L1, S/L2	U, V, W	P/+, P1	Earthing (grounding) cable	R/L1, S/L2	U, V, W	R/L1, S/L2	U, V, W	Earthing (grounding) cable	
0.1K-008 to 0.75K-042	M3.5	1.2	2-3.5	2-3.5	2	2	2	2	14	14	2.5	2.5	2.5	
1.5K-070	M4 (M3.5)	1.5	2-4	2-4	2	2	2	2	14	14	2.5	2.5	2.5	
2.2K-100	M4 (M3.5)	1.5	5.5-4	2-4	3.5	2	2	3.5	12	14	4	2.5	4	

- Single-phase 200 V class (220 V input power supply, with a power factor improving AC or DC reactor)

Applicable inverter model FR-D820S-□	Terminal screw size ^{*4}	Tightening torque N·m	Crimp terminal		Cable gauge									
					HIV cables, etc. (mm ²) ^{*1}				AWG/MCM ^{*2}		PVC cables, etc. (mm ²) ^{*3}			
			R/L1, S/L2	U, V, W	R/L1, S/L2	U, V, W	P/+, P1	Earthing (grounding) cable	R/L1, S/L2	U, V, W	R/L1, S/L2	U, V, W	Earthing (grounding) cable	
0.1K-008 to 0.75K-042	M3.5	1.2	2-3.5	2-3.5	2	2	2	2	14	14	2.5	2.5	2.5	
1.5K-070	M4 (M3.5)	1.5	2-4	2-4	2	2	2	2	14	14	2.5	2.5	2.5	
2.2K-100	M4 (M3.5)	1.5	5.5-4	2-4	3.5	2	2	2	12	14	4	2.5	2.5	

- Single-phase 100 V class (110 V input power supply, without a power factor improving AC reactor)

Applicable inverter model FR-D810W-□	Terminal screw size ^{*4}	Tightening torque N·m	Crimp terminal		Cable gauge									
					HIV cables, etc. (mm ²) ^{*1}				AWG/MCM ^{*2}		PVC cables, etc. (mm ²) ^{*3}			
			R/L1, S/L2	U, V, W	R/L1, S/L2	U, V, W	P/+, P1	Earthing (grounding) cable	R/L1, S/L2	U, V, W	R/L1, S/L2	U, V, W	Earthing (grounding) cable	
0.1K-008 to 0.4K-025	M3.5	1.2	2-3.5	2-3.5	2	2	2	2	14	14	2.5	2.5	2.5	
0.75K-042	M4 (M3.5)	1.5	5.5-4	2-4	3.5	2	2	2	12	14	4	2.5	2.5	

- Single-phase 100 V class (110 V input power supply, with a power factor improving AC reactor)

Applicable inverter model FR-D810W-□	Terminal screw size ^{*4}	Tightening torque N·m	Crimp terminal		Cable gauge									
					HIV cables, etc. (mm ²) ^{*1}				AWG/MCM ^{*2}		PVC cables, etc. (mm ²) ^{*3}			
			R/L1, S/L2	U, V, W	R/L1, S/L2	U, V, W	P/+, P1	Earthing (grounding) cable	R/L1, S/L2	U, V, W	R/L1, S/L2	U, V, W	Earthing (grounding) cable	
0.1K-008 to 0.4K-025	M3.5	1.2	2-3.5	2-3.5	2	2	2	2	14	14	2.5	2.5	2.5	
0.75K-042	M4	1.5	5.5-4	2-4	3.5	2	2	2	12	14	4	2.5	2.5	

- *1 HIV cable (600 V grade heat-resistant PVC insulated wire) with a continuous maximum permissible temperature of 75°C. It assumes a surrounding air temperature of 50°C or lower and the wiring distance of 20 m or shorter.
- *2 THHW cable with a continuous maximum permissible temperature of 75°C. It assumes a surrounding air temperature of 40°C or lower and the wiring distance of 20 m or shorter.
(For the use in the United States or Canada, refer to "Instructions for UL and cUL" in the document enclosed with the product.)
- *3 PVC cable with a continuous maximum permissible temperature of 70°C. It assumes a surrounding air temperature of 40°C or lower and the wiring distance of 20 m or shorter.
(Selection example mainly for use in Europe.)
- *4 The screw size for terminals R/L1, S/L2, T/L3, U, V, W, PR, P/+, N/-, and P1, and the earthing (grounding) terminal is shown. (For the single-phase 200 V power input models, the screw size for terminals R/L1, S/L2, U, V, W, PR, P/+, N/-, and P1, and the earthing (grounding) terminal is shown. For the single-phase 100 V power input models, the screw size for terminals R/L1, S/L2, U, V, W, PR, P/+, and N/-, and the earthing (grounding) terminal is shown.)
The screw size for the earthing (grounding) terminal on FR-D820-1.5K-070 to 3.7K-165, FR-D820-15K-580, FR-D840-2.2K-050 to 3.7K-081, FR-D820S-1.5K-070, FR-D820S-2.2K-100, and FR-D810W-0.75K-042 is indicated in parentheses.

◆ For the SLD rating

- Three-phase 200 V class (220 V input power supply, without a power factor improving AC or DC reactor)

Applicable inverter model FR-D820-[]	Terminal screw size ^{*4}	Tightening torque N·m	Crimp terminal		Cable gauge									
					HIV cables, etc. (mm ²) ^{*1}				AWG/MCM ^{*2}		PVC cables, etc. (mm ²) ^{*3}			
			R/L1, S/L2, T/L3	U, V, W	R/L1, S/L2, T/L3	U, V, W	P/+, P1	Earthing (grounding) cable	R/L1, S/L2, T/L3	U, V, W	R/L1, S/L2, T/L3	U, V, W	Earthing (grounding) cable	
0.1K-008 to 0.75K-042	M3.5	1.2	2-3.5	2-3.5	2	2	2	2	2	14	14	2.5	2.5	2.5
1.5K-070	M4 (M3.5)	1.5	2-4	2-4	2	2	2	2	2	14	14	2.5	2.5	2.5
2.2K-100	M4 (M3.5)	1.5	5.5-4	5.5-4	3.5	3.5	3.5	3.5	3.5	12	12	4	4	4
3.7K-165	M4 (M3.5)	1.5	5.5-4	5.5-4	5.5	5.5	5.5	5.5	5.5	10	10	6	6	6
5.5K-238	M5	2.5	14-5	8-5	14	8	14	5.5	5.5	6	8	16	10	6
7.5K-318	M5	2.5	14-5	14-5	14	14	14	8	8	6	6	16	16	10
11K-450	M5	2.5	22-5	22-5	22	22	22	14	14	4	4	25	25	16
15K-580	M6 (M5)	4.4	38-S6	22-6	38	22	38	14	14	2	4	35	25	25

- Three-phase 200 V class (220 V input power supply, with a power factor improving AC or DC reactor)

Applicable inverter model FR-D820-[]	Terminal screw size ^{*4}	Tightening torque N·m	Crimp terminal		Cable gauge									
					HIV cables, etc. (mm ²) ^{*1}				AWG/MCM ^{*2}		PVC cables, etc. (mm ²) ^{*3}			
			R/L1, S/L2, T/L3	U, V, W	R/L1, S/L2, T/L3	U, V, W	P/+, P1	Earthing (grounding) cable	R/L1, S/L2, T/L3	U, V, W	R/L1, S/L2, T/L3	U, V, W	Earthing (grounding) cable	
0.1K-008 to 0.75K-042	M3.5	1.2	2-3.5	2-3.5	2	2	2	2	2	14	14	2.5	2.5	2.5
1.5K-070	M4 (M3.5)	1.5	2-4	2-4	2	2	2	2	2	14	14	2.5	2.5	2.5
2.2K-100	M4 (3.5)	1.5	5.5-4	5.5-4	3.5	3.5	3.5	3.5	3.5	12	12	4	4	4
3.7K-165	M4 (M3.5)	1.5	5.5-4	5.5-4	5.5	5.5	5.5	5.5	5.5	10	10	6	6	6
5.5K-238	M5	2.5	8-5	8-5	8	8	14	5.5	5.5	8	8	10	10	6
7.5K-318	M5	2.5	14-5	14-5	14	14	14	8	8	6	6	16	16	10
11K-450	M5	2.5	22-5	22-5	22	22	22	14	14	4	4	25	16	16
15K-580	M6 (M5)	4.4	22-6	22-6	22	22	38	14	14	4	4	25	25	25

- Three-phase 400 V class (440 V input power supply, without a power factor improving AC or DC reactor)

Applicable inverter model FR-D840-[]	Terminal screw size ^{*4}	Tightening torque N·m	Crimp terminal		Cable gauge									
					HIV cables, etc. (mm ²) ^{*1}				AWG/MCM ^{*2}		PVC cables, etc. (mm ²) ^{*3}			
			R/L1, S/L2, T/L3	U, V, W	R/L1, S/L2, T/L3	U, V, W	P/+, P1	Earthing (grounding) cable	R/L1, S/L2, T/L3	U, V, W	R/L1, S/L2, T/L3	U, V, W	Earthing (grounding) cable	
0.4K-012 to 1.5K-037	M3.5	1.2	2-3.5	2-3.5	2	2	2	2	2	14	14	2.5	2.5	2.5
2.2K-050	M4 (M3.5)	1.5	2-4	2-4	2	2	2	2	2	14	14	2.5	2.5	2.5
3.7K-081	M4 (M3.5)	1.5	2-4	2-4	2	2	2	2	2	12	14	2.5	2.5	2.5
5.5K-120	M4	1.5	5.5-4	5.5-4	3.5	3.5	3.5	3.5	3.5	12	12	4	4	4
7.5K-163	M4	1.5	5.5-4	5.5-4	5.5	5.5	5.5	5.5	5.5	10	10	6	6	6
11K-230	M4	1.5	8-4	5.5-4	8	5.5	5.5	5.5	5.5	8	10	10	6	10
15K-295	M5	2.5	8-5	8-5	8	8	8	8	8	8	8	10	10	16

- Three-phase 400 V class (440 V input power supply, with a power factor improving AC or DC reactor)

Applicable inverter model FR-D840-[]	Terminal screw size ^{*4}	Tightening torque N·m	Crimp terminal		Cable gauge									
					HIV cables, etc. (mm ²) ^{*1}				AWG/MCM ^{*2}		PVC cables, etc. (mm ²) ^{*3}			
			R/L1, S/L2, T/L3	U, V, W	R/L1, S/L2, T/L3	U, V, W	P/+, P1	Earthing (grounding) cable	R/L1, S/L2, T/L3	U, V, W	R/L1, S/L2, T/L3	U, V, W	Earthing (grounding) cable	
0.4K-012 to 1.5K-037	M3.5	1.2	2-3.5	2-3.5	2	2	2	2	2	14	14	2.5	2.5	2.5
2.2K-050	M4 (M3.5)	1.5	2-4	2-4	2	2	2	2	2	14	14	2.5	2.5	2.5
3.7K-081	M4 (M3.5)	1.5	2-4	2-4	2	2	3.5	2	2	14	14	2.5	2.5	2.5

Applicable inverter model FR-D840-□	Terminal screw size ^{*4}	Tightening torque N·m	Crimp terminal		Cable gauge									
					HIV cables, etc. (mm ²) ^{*1}				AWG/MCM ^{*2}		PVC cables, etc. (mm ²) ^{*3}			
			R/L1, S/L2, T/L3	U, V, W	R/L1, S/L2, T/L3	U, V, W	P/+, P1	Earthing (grounding) cable	R/L1, S/L2, T/L3	U, V, W	R/L1, S/L2, T/L3	U, V, W	Earthing (grounding) cable	
5.5K-120	M4	1.5	5.5-4	5.5-4	3.5	3.5	3.5	3.5	3.5	12	12	4	4	4
7.5K-163	M4	1.5	5.5-4	5.5-4	5.5	5.5	5.5	5.5	5.5	10	10	6	6	6
11K-230	M4	1.5	5.5-4	5.5-4	5.5	5.5	8	5.5	5.5	10	10	6	6	6
15K-295	M5	2.5	8-5	8-5	8	8	14	8	8	8	8	10	10	10

*1 HIV cable (600 V grade heat-resistant PVC insulated wire) with a continuous maximum permissible temperature of 75°C. It assumes a surrounding air temperature of 50°C or lower and the wiring distance of 20 m or shorter.

*2 THHW cable with a continuous maximum permissible temperature of 75°C. It assumes a surrounding air temperature of 40°C or lower and the wiring distance of 20 m or shorter.

(For the use in the United States or Canada, refer to "Instructions for UL and cUL" in the document enclosed with the product.)

*3 PVC cable with a continuous maximum permissible temperature of 70°C. It assumes a surrounding air temperature of 40°C or lower and the wiring distance of 20 m or shorter.

(Selection example mainly for use in Europe.)

*4 The screw size for terminals R/L1, S/L2, T/L3, U, V, W, PR, P/+, N/-, and P1, and the earthing (grounding) terminal is shown.

The screw size for the earthing (grounding) terminal on FR-D820-1.5K-070 to 3.7K-165, FR-D820-15K-580, FR-D840-2.2K-050, and FR-D840-3.7K-081 is indicated in parentheses.

The line voltage drop can be calculated by the following formula:

$$\frac{\sqrt{3} \times \text{wire resistance [m}\Omega\text{/m]} \times \text{wiring distance [m]} \times \text{current [A]}}{1000}$$

Line voltage drop [V] =

Use a larger diameter cable when the wiring distance is long or when the voltage drop (torque reduction) in the low speed range needs to be reduced.

NOTE

- Tighten the terminal screw to the specified torque.
- A screw that has been tightened too loosely can cause a short circuit or malfunction.
- A screw that has been tightened too tightly can cause a short circuit or malfunction due to the unit breakage.
- Use crimp terminals with insulation sleeves to wire the power supply and motor.

◆ Total wiring length

■ With induction motor

Connect one or more general-purpose motors within the total wiring length shown in the following table.

Cable type	Pr.72 setting (carrier frequency)	Voltage class	0.1K	0.2K	0.4K	0.75K	1.5K	2.2K	3.7K or higher
Unshielded	1 (1 kHz) or lower	100/200 V	200 m	200 m	300 m	500 m	500 m	500 m	500 m
		400 V	—	—	200 m	200 m	300 m	500 m	500 m
	2 (2 kHz) or higher	100/200 V	30 m	100 m	200 m	300 m	500 m	500 m	500 m
		400 V	—	—	30 m	100 m	200 m	300 m	500 m
Shielded	1 (1 kHz) or lower	100/200 V	50 m	50 m	75 m	100 m	100 m	100 m	100 m
		400 V	—	—	50 m	50 m	75 m	100 m	100 m
	2 (2 kHz) or higher	100/200 V	10 m	25 m	50 m	75 m	100 m	100 m	100 m
		400 V	—	—	10 m	25 m	50 m	75 m	100 m

Total wiring length (FR-D820-1.5K-070 or higher/FR-D840-3.7K-081 or higher), unshielded cable

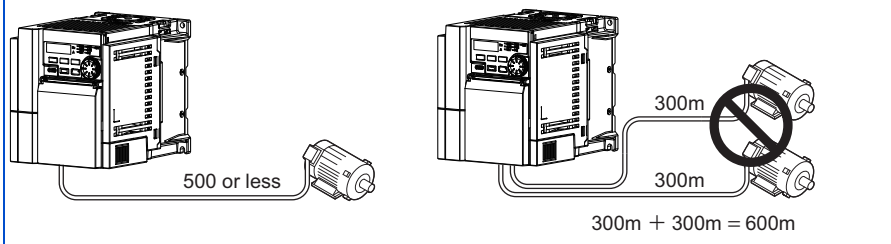

When driving a 400 V class motor by the inverter, surge voltages attributable to the wiring constants may occur at the motor terminals, deteriorating the insulation of the motor. In this case, take one of the following measure.

- Use a "400 V class inverter-driven insulation-enhanced motor" and set **Pr.72 PWM frequency selection** according to the wiring length.

Wiring length 50 m or shorter	Wiring length 50 to 100 m	Wiring length longer than 100 m
14.5 kHz or lower	8 kHz or lower	2 kHz or lower

■ With PM motor

Use the wiring length of 30 m or shorter when connecting a PM motor.

Use one PM motor for one inverter. Multiple PM motors cannot be connected to an inverter.

NOTE

- Especially for long-distance wiring or wiring with shielded cables, the inverter may be affected by a charging current caused by stray capacitance of the wiring, leading to an activation of the overcurrent protection, malfunction of the fast-response current limit operation, stall prevention or even to an inverter failure. It may also cause a malfunction or fault of the equipment connected ON the inverter output side. Stray capacitance of the wiring differs by the installation condition, use the total wiring length in the table above as reference values. If the fast-response current limit function malfunctions, disable the function. If the stall prevention function malfunctions, increase the stall level. (Refer to **Pr.156 Stall prevention operation selection** in the Instruction Manual (Function).)
- A surge voltage suppression filter (FR-ASF-H/FR-BMF-H) can be used under V/F control and Advanced magnetic flux vector control.
- For details of **Pr.72 PWM frequency selection**, refer to the Instruction Manual (Function).
- Refer to [page 100](#) to drive a 400 V class motor by an inverter.
- The carrier frequency is limited during PM sensorless vector control. (Refer to the Instruction Manual (Function).)

2.5.4 Earthing (grounding) precautions

Always earth (ground) the motor and inverter.

◆ Purpose of earthing (grounding)

Generally, an electrical apparatus has an earth (ground) terminal, which must be connected to the ground before use.

An electrical circuit is usually insulated by an insulating material and encased. However, it is impossible to manufacture an insulating material that can shut off a leakage current completely, and actually, a slight current flows into the case. The purpose of earthing (grounding) the case of an electrical apparatus is to prevent operators from getting an electric shock from this leakage current when touching it.

To avoid the influence of external noises, the earthing (grounding) is important to EMI-sensitive equipment that handle low-level signals or operate very fast such as audio equipment, sensors, and computers.

◆ Earthing (grounding) system to be established

As described previously, the purpose of earthing (grounding) is roughly classified into the electrical shock prevention and the prevention of malfunction due to the influence of electromagnetic noise. These two purposes should be clearly distinguished, and the appropriate earth (ground) system must be established to prevent the leakage current having the inverter's high frequency components from reversing through another earth (ground) point for malfunction prevention by following these instructions:

- Make the separate earth (ground) connection (I) for the inverter from any other devices wherever possible.
- Establishing adequate common (single-point) earth (ground) system (II) is allowed if the separate earth (ground) system (I) is not feasible. Do not make inadequate common (single-point) earth (ground) connection (III).
- As leakage currents containing many high frequency components flows into the earthing (grounding) cables of the inverter and peripheral devices (including a motor), the inverter must also be earthed (grounded) separately from EMI-sensitive devices described above.

In a high building, it may be effective to use its iron structure frames as earthing (grounding) electrode for EMI prevention in order to separate from the earth (ground) system for electric shock prevention.

- Earthing (grounding) must conform to the requirements of national and local safety regulations and electrical codes. (NEC section 250, IEC 61140 class 1 and other applicable standards). A neutral-point earthed (grounded) power supply for 400 V class inverter in compliance with EN standard must be used.
- Use the thickest possible earthing (grounding) cable. The size of the earthing (grounding) cable should be the same or larger than the one indicated in the table on Page 53.
- The earthing (grounding) point should be as close as possible to the inverter, and the earth (ground) wire length should be as short as possible.
- Run the earthing (grounding) cable as far away as possible from the I/O wiring of the EMI-sensitive devices and run them in parallel in the minimum distance.

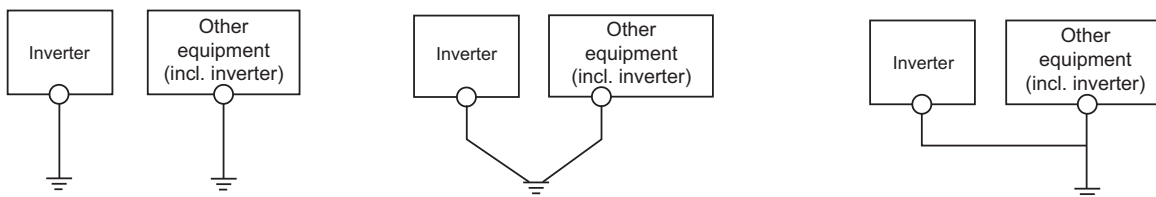

(I) Separate earthing (grounding): Good (II) Common (single-point) earthing (grounding): OK (III) Inadequate common (single-point) earthing (grounding): Bad

NOTE

- To be compliant with the EU Directive (Low Voltage Directive), refer to the document enclosed with the product.

2.6 Control circuit

2.6.1 Details on the control circuit terminals

◆ Input signal

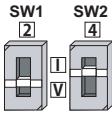
Type	Terminal symbol	Common	Terminal name	Terminal function description		Rated specification	Refer to page
Contact input	STF ^{*1}	SD (sink (negative common))	Forward rotation start	Turn ON the STF signal to start forward rotation and turn it OFF to stop.	When the STF and STR signals are turned ON simultaneously, the stop command is given.	Input resistance: 4.7 kΩ, voltage when contacts are open: 21 to 26 VDC, current when contacts are short-circuited: 4 to 6 mADC	*2
	STR ^{*1}		Reverse rotation start	Turn ON the STR signal to start reverse rotation and turn it OFF to stop.			
	RH RM RL ^{*1}		Multi-speed selection	Multi-speed can be selected according to the combination of RH, RM and RL signals.			
			Pulse train input	Terminal RM is also used as a pulse train input terminal. To use as a pulse train input terminal, change the Pr.291 setting.			
Frequency setting	10	5	Frequency setting power supply	Used as the power supply for an external frequency setting (speed setting) potentiometer.		5 ± 0.5 VDC, permissible load current: 10 mA	*2
	2	5	Frequency setting (voltage)	Inputting 0 to 5 VDC (or 0 to 10 VDC) provides the maximum output frequency at 5 V (or 10 V) and makes input and output proportional. Use Pr.73 to switch among input 0 to 5 VDC (initial setting), 0 to 10 VDC, and 0 to 20 mA. * The initial setting varies depending on the specification. Set the voltage/current input switch to the "I" position to select current input (0 to 20 mA).		For voltage input, input resistance: 10 ± 1 kΩ, maximum permissible voltage: 20 VDC. For current input, input resistance: 245 ± 5 Ω, maximum permissible current: 30 mA.	*2
	4	5	Frequency setting (current)	Inputting 4 to 20 mADC (or 0 to 5 VDC, 0 to 10 VDC) provides the maximum output frequency at 20 mA and makes input and output proportional. This input signal is valid only when the AU signal is ON (terminal 2 input is invalid). To use the terminal 4 (current input at initial setting), assign "4" to any parameter from Pr.178 to Pr.182 (Input terminal function selection) before turning ON the AU signal. Use Pr.267 to switch among input 4 to 20 mA (initial setting), 0 to 5 VDC, and 0 to 10 VDC. * The initial setting varies depending on the specification. Set the voltage/current input switch to the "V" position to select voltage input (0 to 5 V / 0 to 10 V).		Voltage/current input switches 	*2

*1 Terminal functions can be selected using **Pr.178 to Pr.182 (Input terminal function selection)**. (Refer to the Instruction Manual (Function).)
 *2 Refer to the Instruction Manual (Function).

◆ Output signal

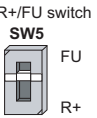
Type	Terminal symbol	Common	Terminal name	Terminal function description	Rated specification	Refer to page	
Relay	A, B, C ^{*1}	—	Relay output (fault output)	1 changeover contact output that indicates that an inverter's protective function has been activated and the outputs are stopped. Fault: discontinuity across B and C (continuity across A and C), Normal: continuity across B and C (discontinuity across A and C)	Contact capacity: 240 VAC 2 A (power factor = 0.4), 30 VDC 1 A	^{*3}	
Open collector	RUN ^{*1}	SE	Inverter running	The output is in LOW state when the inverter output frequency is equal to or higher than the starting frequency (initial value: 0.5 Hz). The output is in HIGH state during stop or DC injection brake operation. ^{*2}	Permissible load: 24 VDC (27 VDC at maximum), 0.1 A (The voltage drop is 3.4 V at maximum while the signal is ON.) 	^{*3}	
	R+/FU ^{*1*2}	R+ FU	— SE	Inverter reception terminal Frequency detection		The output is in LOW state when the inverter output frequency is equal to or higher than the preset detection frequency, and is in HIGH state when it is less than the preset detection frequency. When nothing is connected to the PU connector, this terminal can be switched to terminal R+ by switching the R+/FU switch to R+, and communication can be performed via the RS-485 terminals. Since the RS-485 communication circuit is shared with the PU connector, the PU connector and this terminal (R+) cannot perform RS-485 communication at the same time.	^{*3}
Analog	AM ^{*3}	5	Analog voltage output	Among several monitor items such as output frequency, select one to output it via this terminal. (The signal is not output during an inverter reset.) The output signal is proportional to the magnitude of the corresponding monitoring item.	Output item: Output frequency (initial setting)	Output signal: 0 to 10 VDC, permissible load current: 1 mA (load impedance 10 kΩ or more), resolution: 12 bits	^{*3}

*1 Terminal functions can be selected using **Pr.190 to Pr.192 (Output terminal function selection)**. (Refer to the Instruction Manual (Function).)

*2 Terminal R+/FU functions as the open collector output terminal FU in the initial setting. To use the terminal as the RS-485 terminal R+, set the switch to R+.

*3 Refer to the Instruction Manual (Function).

◆ Safety stop signal

Terminal symbol	Common	Terminal name	Terminal function description	Rated specification	Refer to page
S1	PC	Safety stop input (channel 1)	Use terminals S1 and S2 to receive the safety stop signal input from the safety relay module. Terminals S1 and S2 can be used at a time (dual channel). The Inverter judges the condition of the internal safety circuit from the status (shorted/opened) between terminals S1 and PC, or between S2 and PC. When the status is opened, the inverter output is shut off. In the initial status, terminal S1 and S2 are shorted with terminal PC by shorting wires. Remove the shorting wires and connect the safety relay module when using the safety stop function.	Input resistance: 4.7 kΩ, voltage when contacts are open: 21 to 26 VDC current when contacts are short-circuited: 4 to 6 mADC	68
S2	PC	Safety stop input (channel 2)			
So (SO)	SoC (SOC)	Safety monitor output (open collector output)	The output status varies depending on the input status of the safety stop signals. The output is in HIGH state during occurrence of the internal safety circuit fault. The output is in LOW state otherwise ^{*1} . Refer to the Instruction Manual (Functional Safety) when the signal is switched to HIGH while both terminals S1 and S2 are open. (Contact your sales representative for the manual.)	Permissible load: 24 VDC (27 VDC at maximum), 0.1 A (The voltage drop is 3.4 V at maximum while the signal is ON.)	

*1 The open collector transistor is ON (conductive) in LOW state. The transistor is OFF (not conductive) in HIGH state.

◆ Common terminal

Terminal symbol	Common	Terminal name	Terminal function description	Rated specification	Refer to page
SD	—	Contact input common (sink (negative common))	Common terminal for the contact input terminal (sink logic).	—	—
		External transistor common (source (positive common))	Connect this terminal to the power supply common terminal of a transistor output (open collector output) device, such as a programmable controller, in the source logic to avoid malfunction by undesirable current.		
		24 VDC power supply common	Common terminal for the 24 VDC power supply (terminal PC). Isolated from terminals 5 and SE.		
PC	—	External transistor common (sink (negative common))	Connect this terminal to the power supply common terminal of a transistor output (open collector output) device, such as a programmable controller, in the sink logic to avoid malfunction by undesirable current.	Power supply voltage range: 22 to 28.8 VDC permissible load current: 100 mA	—
		Safety stop input terminal common	Common terminal for safety stop input terminals.		
		Contact input common (source (positive common))	Common terminal for contact input terminal (source logic).		
	SD	24 VDC power supply	Can be used as a 24 VDC 0.1 A power supply.		
5	—	Frequency setting common	Common terminal for the frequency setting signal (terminal 2 or 4). Do not earth (ground).	—	*1
SE	—	Open collector output common	Common terminal for terminals RUN and FU.	—	—
SoC (SOC)	—	Safety monitor output terminal common	Common terminal for terminal So (SO).	—	68

*1 Refer to the Instruction Manual (Function).

◆ Communication

Type	Terminal symbol	Terminal name	Terminal function description	Refer to page		
RS-485	—	PU connector	RS-485 communication can be made through the PU connector Conforming standard: EIA-485 (RS-485) Transmission format: Multidrop link Communication speed: 300 to 115200 bps Wiring length: 500 m	70		
	RS-485	T+	Inverter transmission terminal	RS-485 communication can be made through the RS-485 terminals. Since the RS-485 communication circuit is shared with the PU connector, the PU connector and this terminal cannot be used at the same time. The PU connector is initially enabled. When using the RS-485 terminals, if nothing is connected to the PU connector, switch the R+/FU switch and the R-/SD switch to R+ and R- respectively. For the information on the installation location of each switch, refer to page 14 .	14	
		T-				
		R+/FU ^{*2}	R+			Inverter reception terminal
			FU			—
		R-/SD ^{*3}	R-			Inverter reception terminal
SD	—					
USB	—	USB connector ^{*1}	USB Type-C connector (receptacle) By connecting the inverter to a personal computer via this connector, FR Configurator ² installed on the computer can be used for setting the inverter, or monitoring or testing the inverter operation. Interface: conforms to USB 2.0 Power supply: 5 V, 100 mA (500 mA maximum)	77		

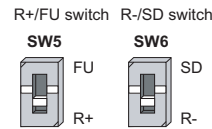

*1 USB bus power connection is available. The maximum SCCR is 500 mA. A PU connector cannot be used during USB bus power connection.

- *2 Terminal R+/FU functions as the open collector output terminal FU in the initial setting. To use the terminal as the RS-485 terminal R+, set the switch to R+.
- *3 Terminal R-/SD functions as the common terminal SD for contact input terminals in the initial setting. To use the terminal as the RS-485 terminal R-, set the switch to R-.

Point

RS-485 communication can be performed with either the PU connector or RS-485 terminals. Since the RS-485 communication circuit is shared with the PU connector, the PU connector and RS-485 terminals cannot be used at the same time. Communication is not possible if both the PU connector and RS-485 terminals are used simultaneously. Do not connect anything to the PU connector when using the RS-485 terminals for communication.

2.6.2 Control logic (sink/source) change

The control logic of input signals can be switched as necessary.

Use the DIP switch on the control circuit board to switch the control logic.

The initial setting of the control logic differs depending on the specification.

(The output signals may be used in either the sink or source logic independently of the switch setting.)

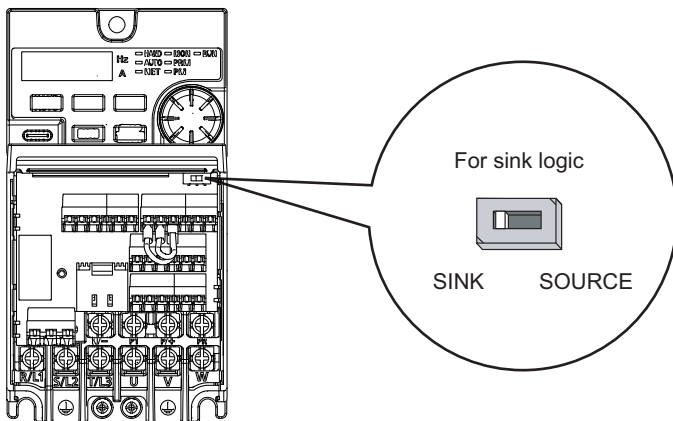

NOTE

- Never change the control logic while power is ON.

◆ Sink logic and source logic

- In the sink logic, a signal turns ON when a current exits from the corresponding signal input terminal.
- Terminal SD is common to the contact input signals. Terminal SE is common to the open collector output signals.
- In the source logic, a signal turns ON when a current enters into the corresponding signal input terminal.
- Terminal PC is common to the contact input signals. Terminal SE is common to the open collector output signals.

● Current flow concerning the input/output signal when sink logic is selected

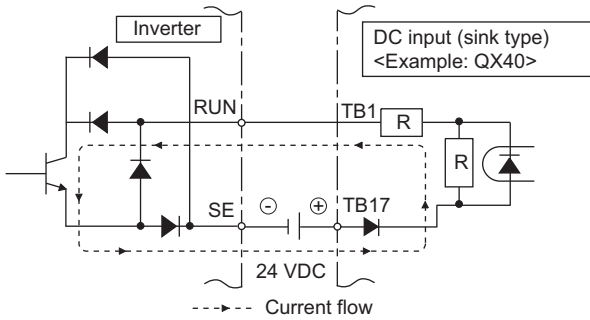
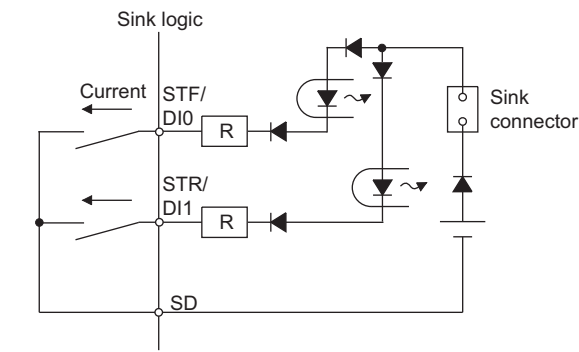

● Current flow concerning the input/output signal when source logic is selected

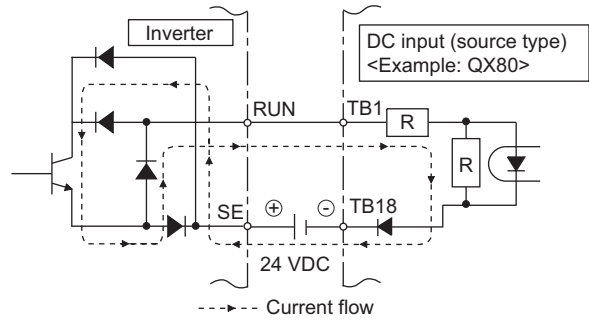
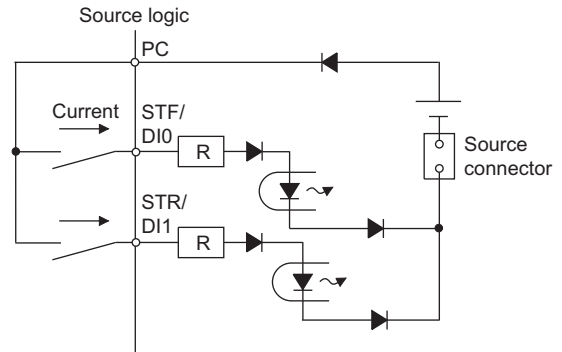

- When using an external power supply for transistor output

Sink logic

Use terminal PC as a common terminal, and perform wiring as follows. (Do not connect terminal SD on the inverter with the terminal of 0 V for the external power supply. When using terminals PC and SD as a 24 VDC power supply, do not install an external power supply in parallel with the inverter. Doing so may cause a malfunction in the inverter due to undesirable currents.)

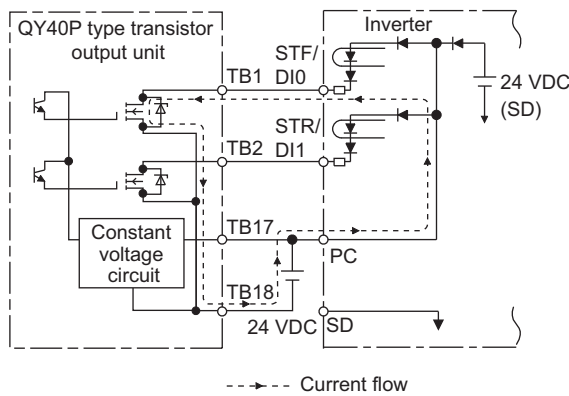

Source logic

Use the terminal SD as a common terminal, and perform wiring as follows. (Do not connect terminal PC on the inverter with the terminal of +24 V for the external power supply. When using terminals PC and SD as a 24 VDC power supply, do not install an external power supply in parallel with the inverter. Doing so may cause a malfunction in the inverter due to undesirable currents.)

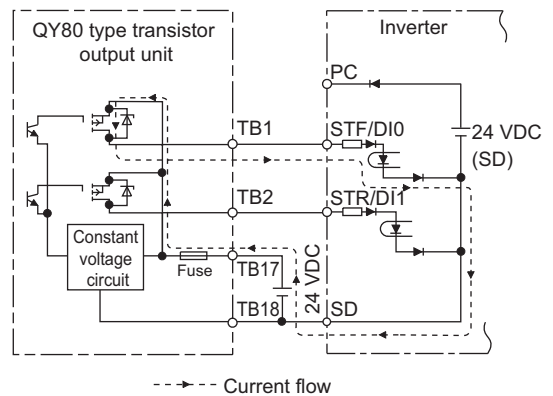

2.6.3 Wiring of control circuit

◆ Control circuit terminal layout

- Recommended cable gauge: 0.3 to 0.75 mm²

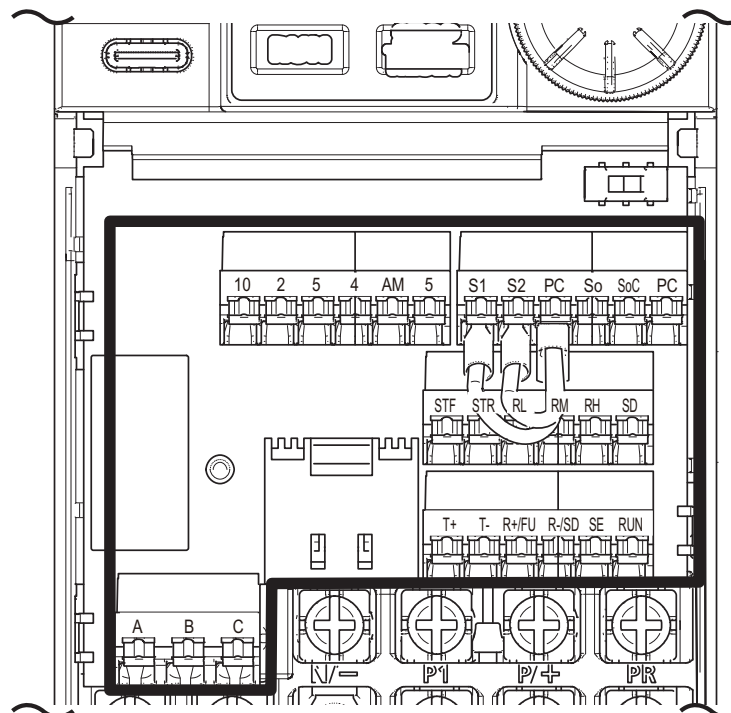

◆ Wiring method

■ Power supply connection

Use crimp terminals and stripped wire for the control circuit wiring. For single wire, the stripped wire can be used without crimp terminal.

Connect the end of wires (crimp terminal or stranded wire) to the terminal block.

1. Strip the signal wires as follows. If too much of the wire is stripped, a short circuit may occur with neighboring wires. If not enough of the wire is stripped, wires may become loose and fall out. Twist the stripped end of wires to prevent them from fraying. Do not solder them.



2. Crimp the terminals on the wire. Insert the wire into a crimp terminal, making sure that 0 to 0.5 mm of the wire protrudes from the end of the sleeve. Check the condition of the crimp terminals after crimping. Do not use the crimp terminals of which the crimping is inappropriate, or the face is damaged.

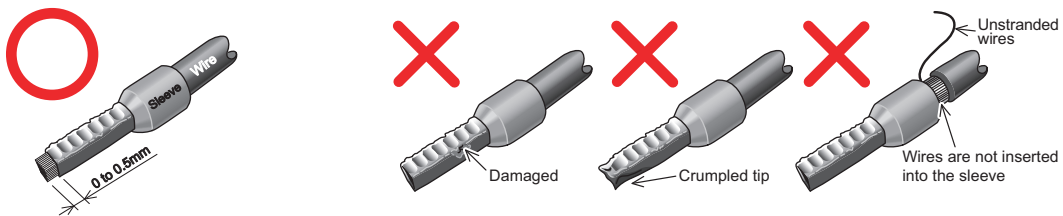

Crimp terminals commercially available (as of April 2023)

- Phoenix Contact GmbH & Co. KG

Wire gauge (mm ²)	Ferrule part No.			Crimping tool model No.
	With insulation sleeve	Without insulation sleeve	For UL wire ^{*1}	
0.3	AI 0,34-10TQ	—	—	CRIMPFOX 6
0.5	AI 0,5-10WH	—	AI 0,5-10WH-GB	
0.75	AI 0,75-10GY	A 0,75-10	AI 0,75-10GY-GB	
1	AI 1-10RD	A 1-10	AI 1-10RD/1000GB	
1.25, 1.5	AI 1,5-10BK	A 1,5-10	AI 1,5-10BK/1000GB ^{*2}	
0.75 (two-wire product)	AI-TWIN 2×0,75-10GY	—	—	

*1 A ferrule terminal with an insulation sleeve compatible with the MTW wire which has a thick wire insulation.

*2 The ferrule terminal is applicable for terminals A, B, and C.

- NICHIFU Co., Ltd.

Wire gauge (mm ²)	Blade terminal part No.	Insulation cap part No.	Crimping tool model No.
0.3 to 0.75	BT 0.75-11	VC 0.75	NH 69

3. Insert the wire into the terminal block.

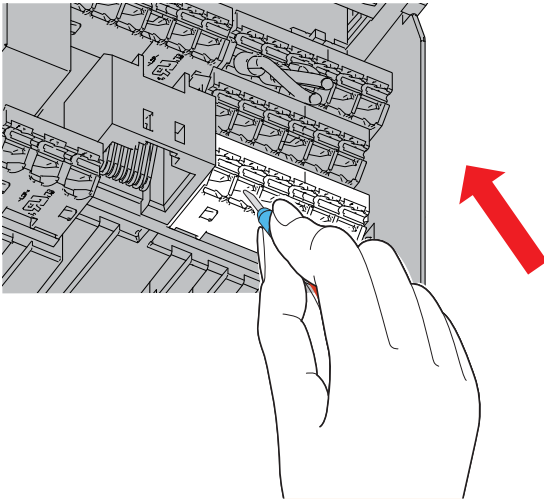

When using single wire or stranded wire without crimp terminal, push the open/close button all the way down with a flathead screwdriver, and insert the wire.

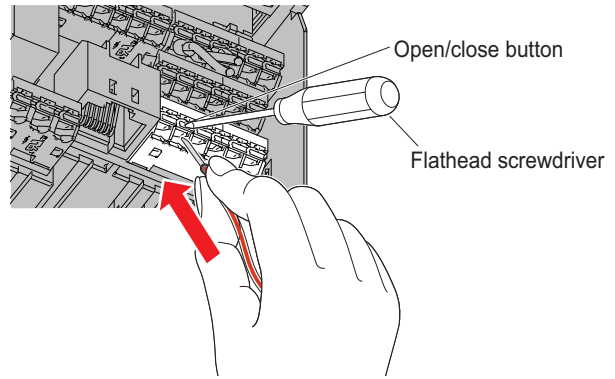

NOTE

- When using stranded wires without a blade terminal, twist enough to avoid short circuit with a nearby terminals or wires.
- Place the flathead screwdriver vertical to the open/close button. In case the blade tip slips, it may cause an inverter damage or injury.

■ Wire removal

Pull the wire while pushing the open/close button all the way down firmly with a flathead screwdriver.

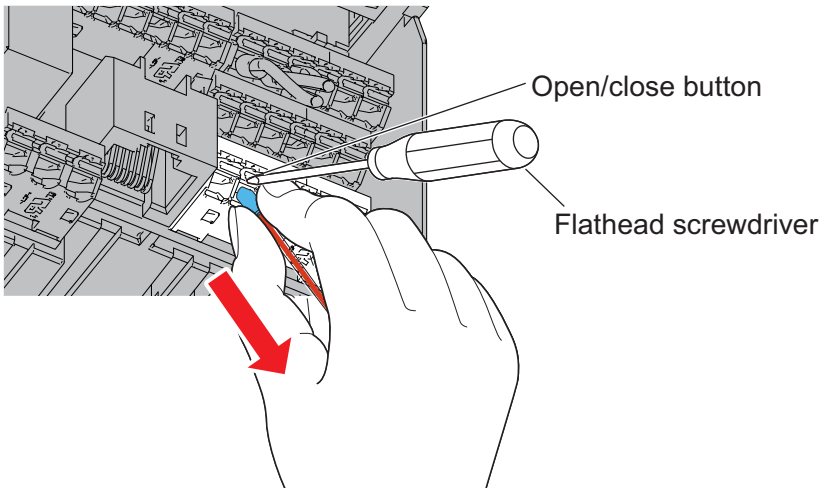

NOTE

- Pulling out the wire forcefully without pushing the open/close button all the way down may damage the terminal block.
- Use a small flathead screwdriver (tip thickness: 0.4 mm / tip width: 2.5 mm).
- If a flathead screwdriver with a narrow tip is used, terminal block may be damaged.
- Commercially available products (as of April 2023)

Product name	Model	Manufacturer
Screwdriver	SZF 0- 0,4 × 2,5	Phoenix Contact Co., Ltd.

- Place the flathead screwdriver vertical to the open/close button. In case the blade tip slips, it may cause an inverter damage or injury.

◆ Common terminals of the control circuit (SD, PC, 5, SE)

- Terminals SD (sink logic), PC (source logic), 5, and SE are common terminals (0 V) for I/O signals. (All common terminals are isolated from each other.) Do not earth (ground) these terminals. Avoid connecting terminal SD (sink logic) with terminal 5, terminal PC (source logic) with terminal 5, and terminal SE with terminal 5.
- In the sink logic, terminal SD is a common terminal for the contact input terminals (STF, STR, RH, RM, RL). The open collector circuit is isolated from the internal control circuit by photocoupler.
- In the source logic, terminal PC is a common terminal for the contact input terminals (STF, STR, RH, RM, RL). The open collector circuit is isolated from the internal control circuit by photocoupler.
- Terminal 5 is a common terminal for the frequency setting terminal (2 or 4) and the analog output terminals (AM). It should be protected from external noise using a shielded or twisted cable.
- Terminal SE is a common terminal for the open collector output terminals (RUN and FU). The contact input circuit is isolated from the internal control circuit by photocoupler.

◆ Signal inputs by contactless switches

The contact input terminals of the inverter (STF, STR, RH, RM, RL) can be controlled using a transistor instead of a contact switch. Refer to [page 63](#) for the connection diagram.

◆ Wiring precautions

- It is recommended to use a cable of 0.3 to 0.75 mm² for the connection to the control circuit terminals.
- The wiring length should be 30 m at the maximum.
- Do not short across terminals PC and SD. Doing so may cause an inverter failure.
- Use two or more parallel micro-signal contacts or twin contacts to prevent contact faults when using contact inputs since the control circuit input signals are micro-currents.

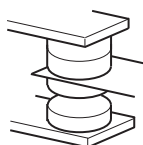

Micro signal contacts

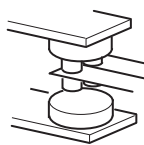

Twin contacts

- To suppress EMI, use shielded or twisted cables for the control circuit terminals and run them away from the main and power circuits (including the 200 V relay sequence circuit). For the cables connected to the control circuit terminals, connect their shields to the common terminal of the connected control circuit terminal. When connecting an external power supply to terminal PC, however, connect the shield of the power supply cable to the negative side of the external power supply. Do not directly earth (ground) the shield to the enclosure, etc.
- Always apply a voltage to the fault output terminals (A, B, C) via a relay coil, lamp, etc.
- When a relay coil is connected to the output terminals, use one with a surge absorbing function (reflux diode). When the voltage application direction is incorrect, the inverter will be damaged. Pay attention to the diode direction or other precautions to avoid incorrect wiring.

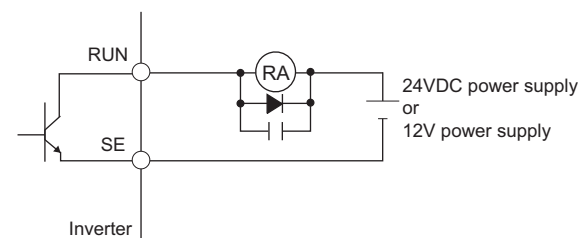

2.6.4 Safety stop function

◆ Function description

The terminals related to the safety stop function are as follows.

Terminal symbol	Terminal function description	
S1 ^{*1}	Input terminal as the safety stop channel 1.	Status of both the circuit between terminals S1 and PC and the circuit between terminals S2 and PC Open: Safety stop function is activated. Shorted: Safety stop function is not activated.
S2 ^{*1}	Input terminal as the safety stop channel 2.	
PC ^{*1}	Common terminal for S1 and S2.	
So (SO)	Outputs alarms or that a fault has been detected The terminal is ON (conducted) while no internal safety circuit failure ^{*2} exists.	OFF: Internal safety circuit failure ^{*2} ON: No internal safety circuit failure ^{*2}
SoC (SOC)	Open collector output (terminal So (SO)) common	

*1 In the initial status, terminals S1 and PC and terminals S2 and PC are respectively shorted with shorting wires.) To enable the safety stop function, remove all the shorting wires, and then connect a safety relay module as shown in the connection diagram.

*2 When any fault listed on the next page occurs in the internal safety circuit, the corresponding indication is shown on the operation panel.

NOTE

- Terminal SO can be used to display a fault indication and to prevent restarting of the inverter. The signal output from terminal SO cannot be used to input a safety stop signal to other devices.

◆ Connection diagram

To prevent restart at fault occurrence, connect terminals So (SO) and SoC (SOC) to the reset button, which are the feedback input terminals of the safety relay module.

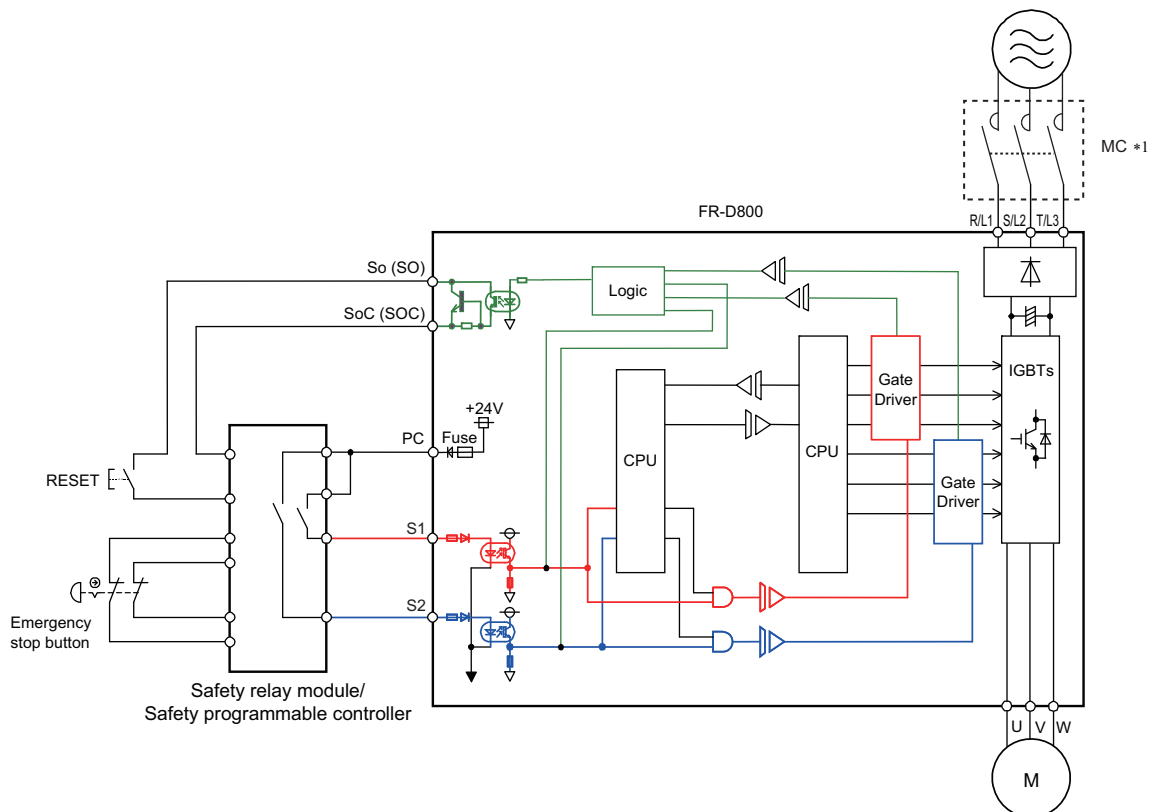

*1 To avoid an electric shock hazard during wiring or inspection, install a magnetic contactor (MC) at the input side of the inverter.

◆ Safety stop function operation

Input power	Internal safety circuit status	Input terminal ^{*1,2}		Output terminal So (SO)	Output signal ^{*8,9,10}		Inverter running status triggered by safety input	Operation panel indication	
		S1	S2		SAFE	SAFE2		E.SAF ^{*6}	SA ^{*7}
OFF	—	—	—	OFF	OFF	OFF	Output shutoff (Safe state)	Not displayed	Not displayed
ON	Normal	ON	ON	ON ^{*3}	OFF	ON ^{*3}	Operation enabled	Not displayed	Not displayed
	Normal	ON	OFF	OFF ^{*4}	OFF ^{*4}	OFF ^{*4}	Output shutoff (Safe state)	Displayed	Displayed
	Normal	OFF	ON	OFF ^{*4}	OFF ^{*4}	OFF ^{*4}	Output shutoff (Safe state)	Displayed	Displayed
	Normal	OFF	OFF	ON ^{*3}	ON ^{*3}	ON ^{*3}	Output shutoff (Safe state)	Not displayed	Displayed
	Fault	ON	ON	OFF	OFF	OFF	Output shutoff (Safe state)	Displayed	Not displayed ^{*5}
	Fault	ON	OFF	OFF	OFF	OFF	Output shutoff (Safe state)	Displayed	Displayed
	Fault	OFF	ON	OFF	OFF	OFF	Output shutoff (Safe state)	Displayed	Displayed
	Fault	OFF	OFF	OFF	OFF	OFF	Output shutoff (Safe state)	Displayed	Displayed

*1 The terminal ON state shows that the terminal is conducted (the line is closed), and the OFF state shows that the terminal is not conducted (the line is open).

*2 When not using the safety stop function, short across terminals S1 and PC and terminals S2 and PC to use the inverter. (In the initial status, terminals S1 and PC and terminals S2 and PC are respectively shorted with shorting wires.)

*3 If any of the faults shown in the following table occurs, terminal So (SO), the SAFE signal, and the SAFE2 signal are turned OFF.

Fault type	Operation panel indication
Internal storage device fault	E.PE6
Parameter storage device fault (control circuit board)	E.PE
Retry count excess	E.RET
Parameter storage device fault (main circuit board)	E.PE2
Safety circuit fault	E.SAF
Overspeed occurrence	E.OS

Fault type	Operation panel indication
CPU fault	E.CPU
	E.5 to E.7
Internal circuit fault	E.13

*4 When the internal safety circuit is operated normally, terminal So (SO), the SAFE signal, and the SAFE2 signal remain ON until "E.SAF" is displayed. Terminal So (SO), the SAFE signal, and the SAFE2 signal are turned OFF when "E.SAF" is displayed.

*5 "SA" is displayed when terminals S1 and S2 are identified as OFF due to the internal safety circuit failure.

*6 If another fault occurs when the fault E.SAF occurs, the other fault indication may be displayed.

*7 If another warning occurs when the warning SA occurs, the other warning indication may be displayed.

*8 The ON/OFF state of the output signal is the one for the positive logic. In negative logic, the signal status is opposite.

*9 To assign the functions of the SAFE signal and SAFE2 signal to output terminals, set either value shown in the following table. To output the signals via physical terminals, the functions can be assigned to **Pr.190 to Pr.192**. (The FU signal is initially assigned to terminal R+/FU.) To output the signals via communication, the functions can also be assigned to **Pr.190 to Pr.196 (Output terminal function selection)** using communication protocols. (Only "80 or 81" are available for **Pr.193 to Pr.196**.) For details, refer to the Instruction Manual (Communication).

Output signal	Pr.190 to Pr.196 setting	
	Positive logic	Negative logic
SAFE	80	180
SAFE2	81	181

*10 The use of the SAFE signal and SAFE2 signal has not been certified for compliance with safety standards.

For details, refer to the Instruction Manual (Functional Safety).

2.7 Communication connectors and terminals

2.7.1 PU connector

◆ Mounting the operation panel on the enclosure surface

- Having an enclosure surface operation panel (FR-PA07) or a parameter unit on the enclosure surface is convenient. With a connection cable, the operation panel or the parameter unit can be mounted to the enclosure surface and connected to the inverter.
- To connect the FR-PA07 or the parameter unit to the inverter, use an option FR-CB2[], or a connector (RJ-45 connector) and cable (communication cable) available on the market.
- Securely insert the connection cable until the stoppers on both ends are fixed.
- Since the communication circuit is shared between the PU connector and the RS-485 terminals, the PU connector and RS-485 terminals cannot be used at the same time. Do not wire the RS-485 terminals for RS-485 communication when using the PU connector. Communication is not possible if both the PU connector and RS-485 terminals are used simultaneously.

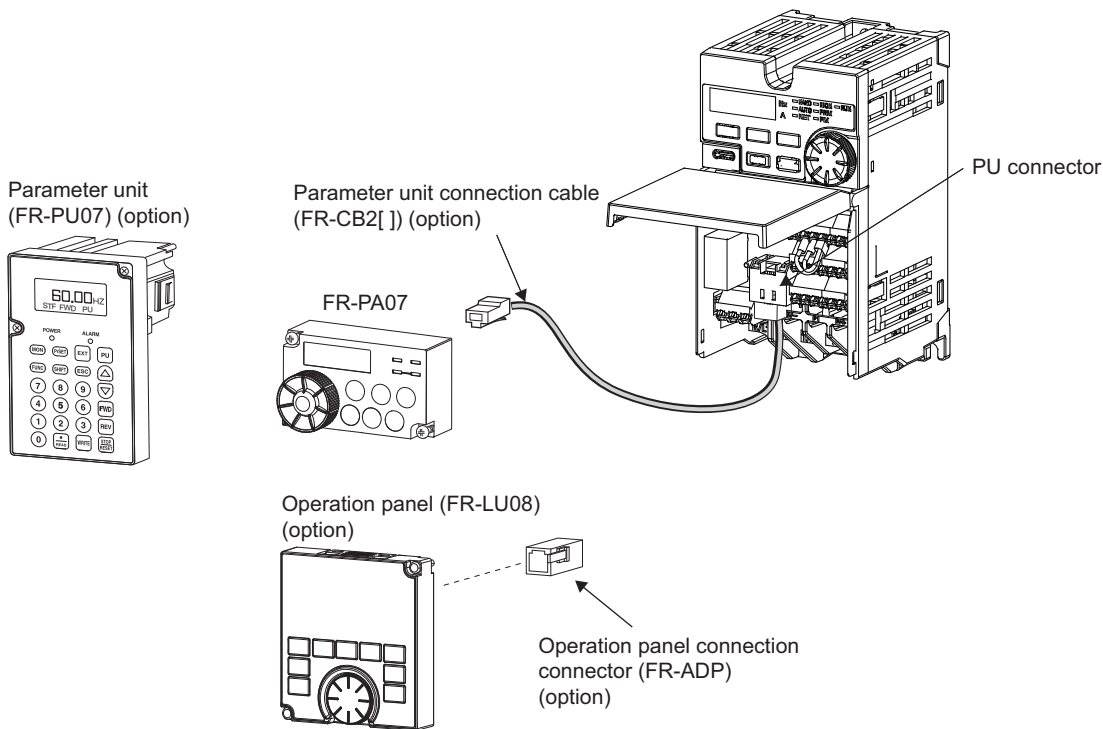

NOTE

- Refer to the following table when fabricating the cable on the user side. Keep the total cable length within 20 m.

Name	Remarks
Communication cable	Cable compliant with EIA-568 (such as 10BASE-T cable)

◆ Communication operation

- Using the PU connector as a computer network port enables communication operation from a personal computer, etc. When the PU connector is connected with a personal, FA or other computer by a communication cable, a user program can run to monitor the inverter or read and write parameters. Communication can be performed with the Mitsubishi inverter protocol (computer link operation) or the MODBUS RTU protocol. For details, refer to the Instruction Manual (Communication).

◆ Before communication

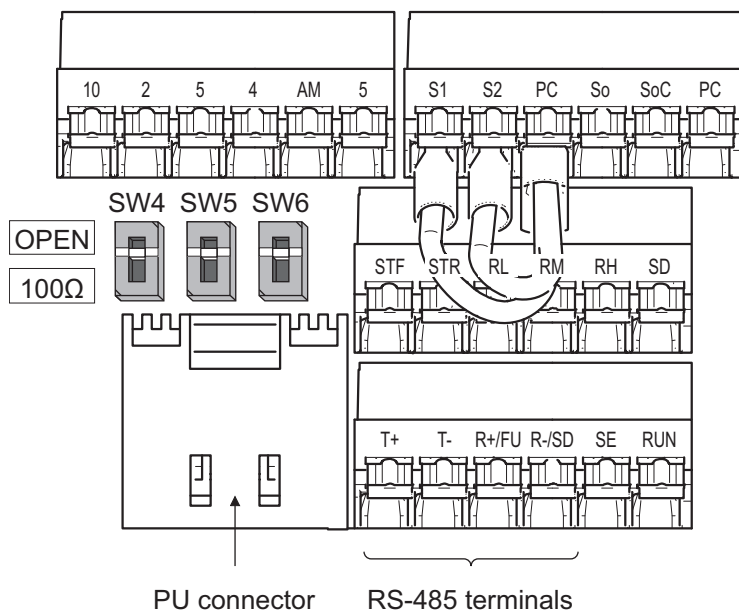

1. If any cable is connected to the RS-485 terminals, remove the wiring. When terminals R+/FU and R-/SD are used as terminals FU and SD, the wiring does not need to be removed.
2. Set the R+/FU switch (SW5) to the upper position (FU) (initial status) and the R-/SD switch (SW6) to the upper position (SD) (initial status).

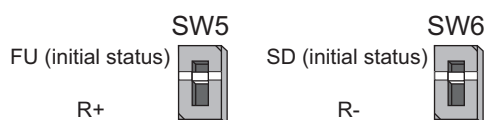

◆ PU connector pin-outs

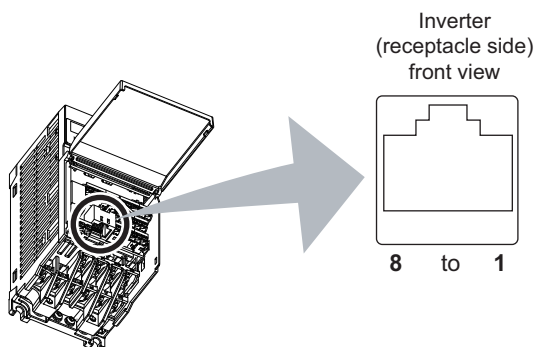

Pin number	Name	Description
1	5 (GND)	Earth (ground)
2	—	Operation panel power supply
3	RDA	Inverter receive+
4	SDB	Inverter send-
5	SDA	Inverter send+
6	RDB	Inverter receive-
7	5 (GND)	Earth (ground)
8	—	Operation panel power supply

NOTE

- Pins No. 2 and 8 provide power to the operation panel or parameter unit. Do not use these pins for RS-485 communication.
- Do not connect the PU connector to the computer's LAN board, FAX modem socket, or telephone modular connector. The product could be damaged due to differences in electrical specifications.

◆ Connection cable

NOTE

Refer to the following for the cable (USB to RS-485 converter) to connect a computer with a USB Type-A port to an inverter. Commercially available products (as of April 2023)

Product name	Model name	Manufacturer
Interface embedded cable dedicated for inverter ^{*1}	DINV-U4	Diatrend Corp.

^{*1} The conversion cable cannot connect multiple inverters. (The computer and inverter are connected in a 1:1 pair.) This is a USB-to-RS-485 converter-embedded conversion cable. No additional cable or connector is required. For the product details, contact the manufacturer.

◆ Distributor

To connect multiple inverters, use distributors.

Commercially available products (as of April 2023)

Product name	Model name	Manufacturer
RS-485 distributor	BMJ-8-28N (Pins No. 2 and No. 8 are not connected internally.) (A plug with a terminating resistor is not used.)	HACHIKO ELECTRIC CO., LTD.
	DMDH-3PN (Pins No. 2 and No. 8 are not connected internally.) DMDH-10PN (Pins No. 2 and No. 8 are not connected internally.)	Diatrend Corp.

◆ PU connector wiring method

- Connecting one inverter (four-wire type)

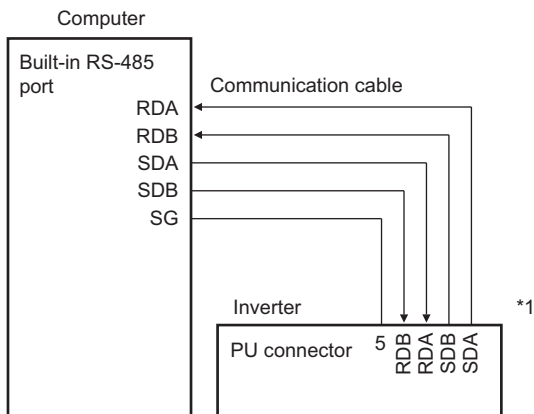

^{*1} Set the terminating resistor switch (SW4) to the 100 Ω side.

• Connecting multiple inverters (four-wire type)

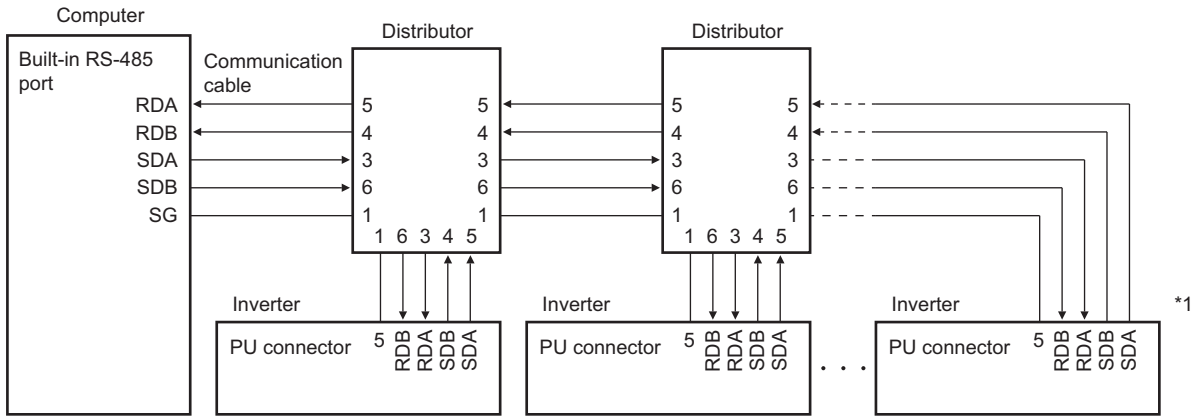

*1 On the inverter most remotely connected with the computer, set the terminating resistor switch (SW4) to the 100 Ω side.

• Connecting one inverter (two-wire type)

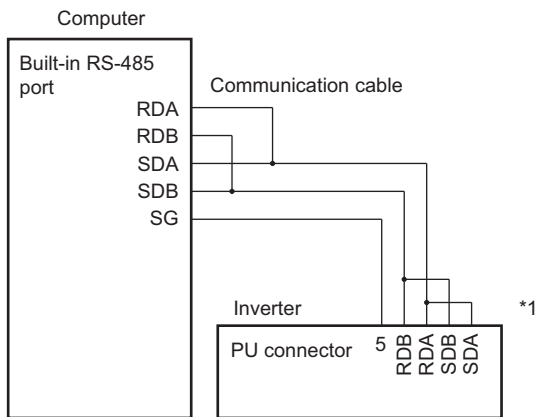

*1 Set the terminating resistor switch (SW4) to the 100 Ω side.

• Connecting multiple inverters (two-wire type)

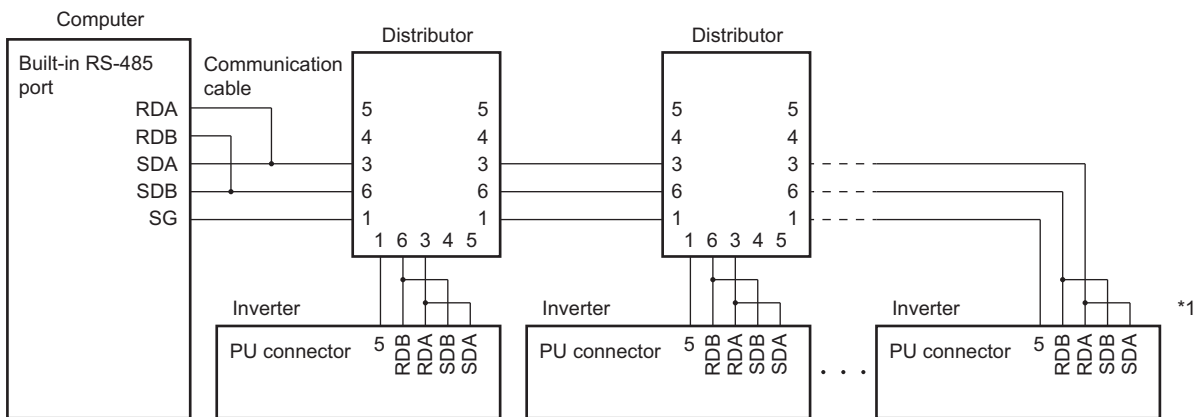

*1 On the inverter most remotely connected with the computer, set the terminating resistor switch (SW4) to the 100 Ω side.

2.7.2 Wiring and configuration of RS-485 terminals

◆ Before communication

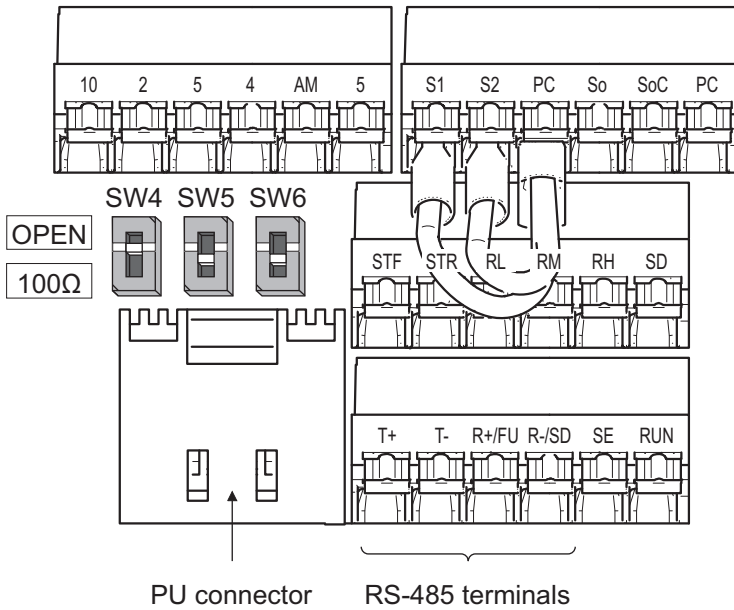

1. If any cable is connected to the PU connector, remove the wiring.
2. Set the R+/FU switch (SW5) to the lower position (R+) and the R-/SD switch (SW6) to the lower position (R-).

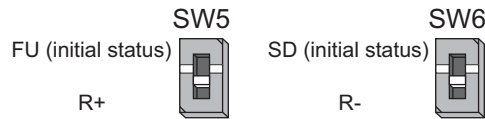

◆ RS-485 terminal layout

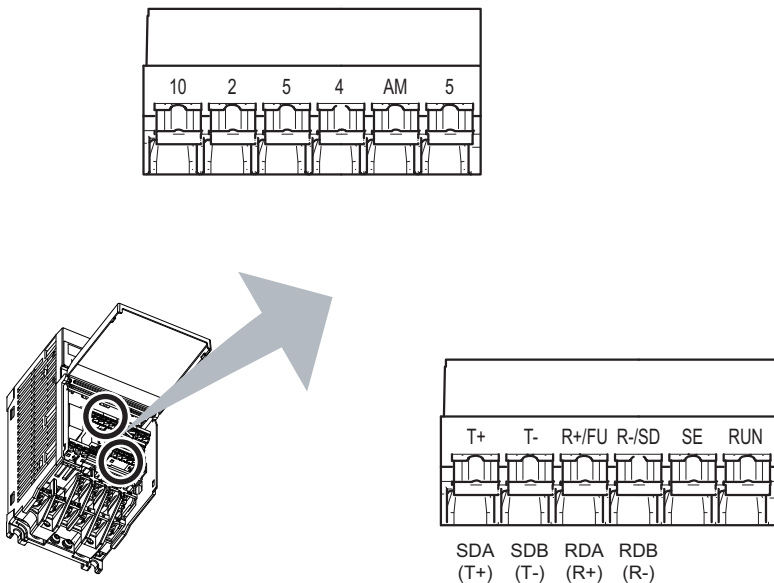

Name	Description
RDA (R+)	Inverter receive+
RDB (R-)	Inverter receive-
SDA (T+)	Inverter send+
SDB (T-)	Inverter send-
5	Earth (ground)

◆ Wiring the RS-485 terminals

- The size of RS-485 terminals is the same as that of other control circuit terminals. Refer to [page 64](#) for the wiring method.

◆ System configuration of RS-485 terminals

- Computer and inverter connection (1:1)

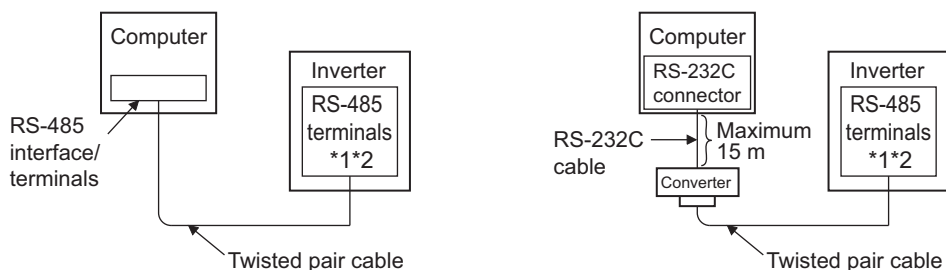

*1 Set the terminating resistor switch (SW4) to the 100 Ω side.

*2 Set the inverter R+/FU switch (SW5) to the lower position (R+) and the R-/SD switch (SW6) to the lower position (R-).

- Combination of a computer and multiple inverters (1:n)

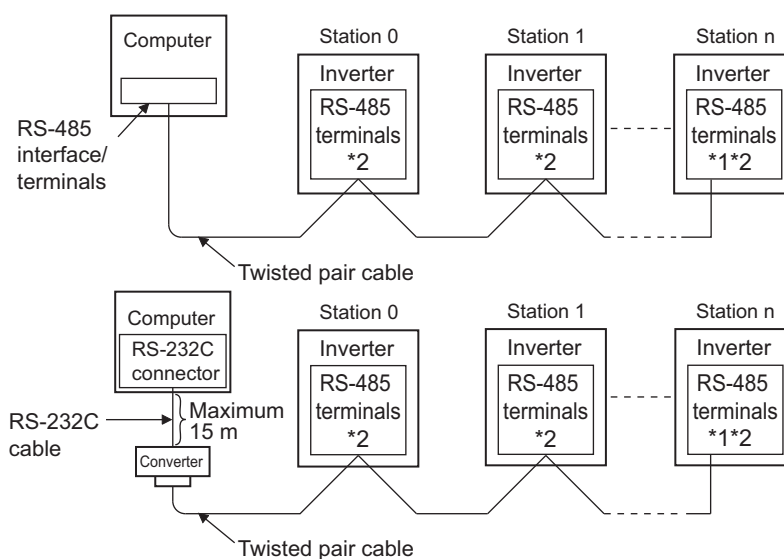

*1 On the inverter most remotely connected with the computer, set the terminating resistor switch (SW4) to the 100 Ω side.

*2 Set the inverter R+/FU switch (SW5) to the lower position (R+) and the R-/SD switch (SW6) to the lower position (R-).

◆ RS-485 terminal wiring method

- Wiring between a computer and an inverter for RS-485 communication

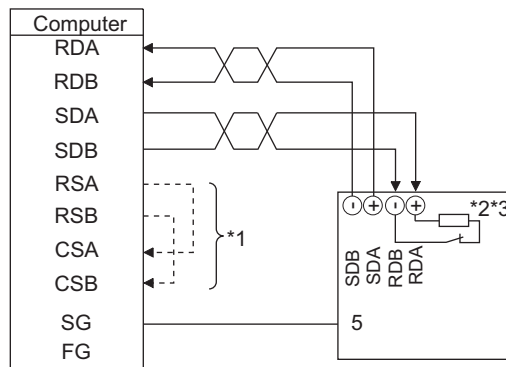

- Wiring between a computer and multiple inverters for RS-485 communication

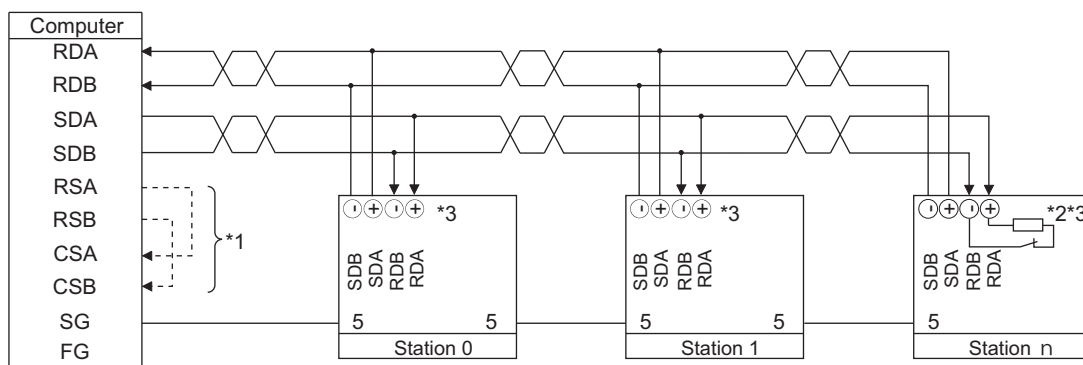

*1 Make connection in accordance with the Instruction Manual of the computer to be used with.

Fully check the terminal numbers of the computer since they vary with the model.

*2 On the inverter most remotely connected with the computer, set the terminating resistor switch (SW4) to the 100 Ω side.

*3 Set the inverter R+/FU switch (SW5) to the lower position (R+) and the R-/SD switch (SW6) to the lower position (R-).

◆ Two-wire type connection

- If the computer is 2-wire type, a connection from the inverter can be changed to 2-wire type by passing wires across reception terminals and transmission terminals of the RS-485 terminals.

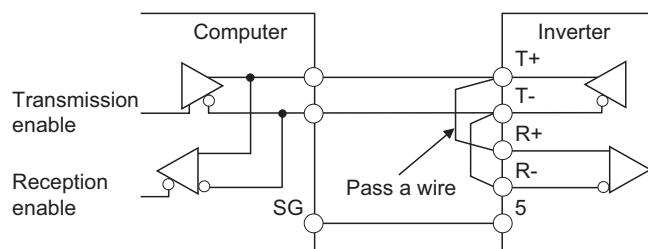

NOTE

- A program should be created so that transmission is disabled (receiving state) when the computer is not sending and reception is disabled (sending state) during sending to prevent the computer from receiving its own data.

2.7.3 USB connector

◆ USB device communication

The inverter can be connected to a computer with a USB cable (connector: USB Type-C). Parameter setting and monitoring can be performed by using FR Configurator2.

Interface	Conforms to USB 2.0
Wiring length	Maximum 5 m
Connector	USB Type-C connector (receptacle)
Power supply	Self-powered or bus power connection

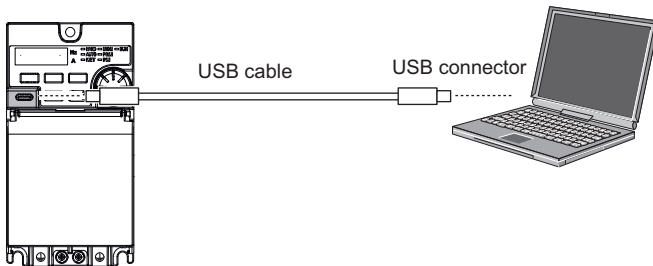

NOTE

- For details on FR Configurator2, refer to the Instruction Manual of FR Configurator2.

◆ USB bus power

When the inverter is connected to a computer via USB, power is supplied and communication with FR Configurator2 is enabled even while the inverter power is OFF. This reduces startup time.

■ Restrictions for using USB bus power

The following table shows availability of functions while power is supplied via USB connection. Note that some functions are restricted.

Item	Description	Remarks
Parameters (except for calibration parameters)	Reading a parameter value Writing a parameter value	—
AM calibration parameter C1 (Pr.901)	Setting (calibration) not available.	—
Calibration parameters (C2 (Pr.902) , C3 (Pr.902) , Pr.125 (Pr.903) , C4 (Pr.903) , C5 (Pr.904) , C6 (Pr.904) , Pr.126 (Pr.905) , C7 (Pr.905))	Adjustment is available only when applying analog voltage (current) is not necessary.	—
Operation panel	Not available for operation. Only the PRM LED turns ON.	When power is supplied via main circuit terminals while the USB bus power is used, the operation panel will be reset automatically.
Fault	Partially supported.	—
RS-485 communication	Not guaranteed.	—

NOTE

- USB power cannot be supplied while using the parameter unit with battery pack (FR-PU07BB) attached to the inverter in battery mode. Supplying USB and battery pack power simultaneously may damage the inverter.

2.8 Connection of stand-alone option units

The inverter accepts a variety of stand-alone option units as required.

Incorrect connection will cause inverter damage or accident. Connect and operate the option unit carefully in accordance with the Instruction Manual of the corresponding option unit.

2.8.1 Connection of the brake resistor (FR-D820-0.4K-025 or higher, FR-D840-0.4K-012 or higher, FR-D820S-0.4K-025 or higher, and FR-D810W-0.4K-025 or higher)

- Install a dedicated brake resistor (MRS, MYS, or FR-ABR) outside when the motor driven by the inverter is made to run by the load, quick deceleration is required, etc. Connect the brake resistor (MRS, MYS, or FR-ABR) to terminals P/+ and PR. (For the locations of terminals P/+ and PR, refer to the terminal block layout ([page 50](#))).
Set parameters as follows.

Connected brake resistor	Setting of Pr.30 Regenerative function selection	Setting of Pr.70 Special regenerative brake duty	
MRS, MYS	0 (initial value)	—	
MYS used at 100% torque / 6%ED	1	FR-D820-3.7K-165	6%
FR-ABR	1	FR-D820-7.5K-318 or lower FR-D840-7.5K-163 or lower FR-D820S-2.2K-100 or lower FR-D810W-0.75K-042 or lower	10%
		FR-D820-11K-450 or higher FR-D840-11K-230 or higher	6%

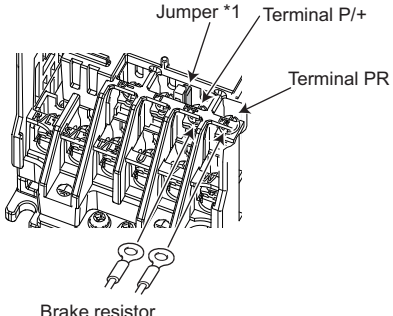
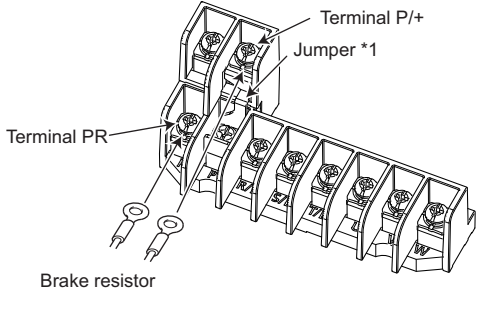
FR-D820-0.4K-025, FR-D820-0.75K-042, FR-D840-0.4K-012 to 1.5K-037, FR-D820S-0.4K-025, FR-D820S-0.75K-042, FR-D810W-0.4K-025	FR-D820-1.5K-070 to 3.7K-165, FR-D840-2.2K-050, FR-D840-3.7K-081, FR-D820S-1.5K-070, FR-D820S-2.2K-100, FR-D810W-0.75K-042
<p>Connect a brake resistor across terminals P/+ and PR.*2</p>  <p>Labels: Jumper *1, Terminal P/+, Terminal PR, Brake resistor</p>	<p>Connect a brake resistor across terminals P/+ and PR.</p>  <p>Labels: Terminal P/+, Jumper *1, Terminal PR, Brake resistor</p>

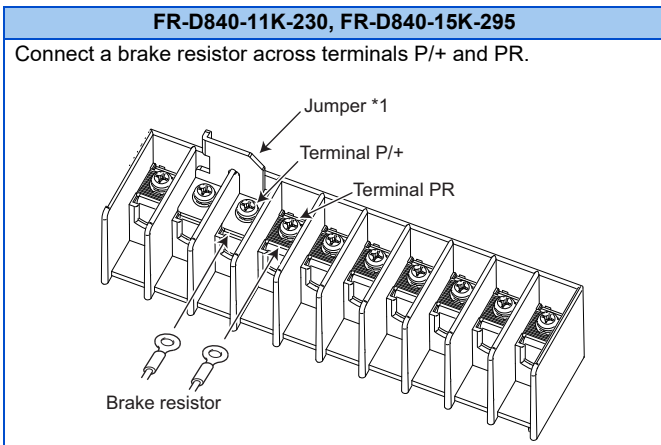
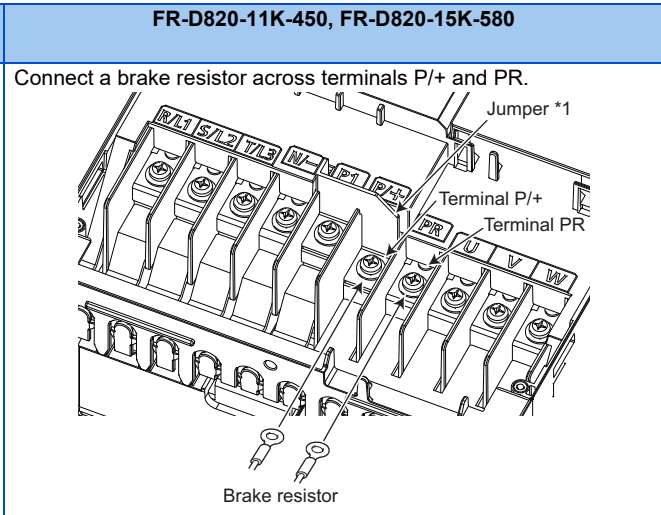
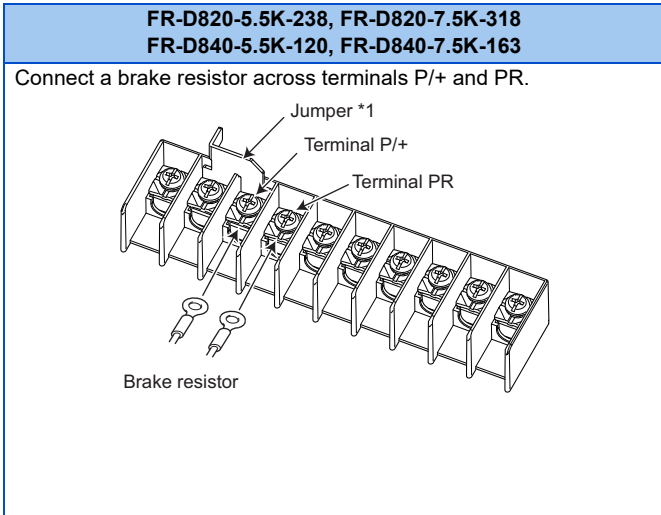

- *1 Do not remove the jumper across terminals P/+ and P1 except when connecting a DC reactor (FR-HEL).
- *2 Connect the brake resistor to the lower terminals on the terminal block (R/L1, S/L2, T/L3, U, V, W) before the upper terminals (N/-, P1, P/+, PR). If the upper terminals are connected first, the lower terminals cannot be connected.

NOTE

- A brake resistor cannot be used with options such as brake units, high power factor converters, and multifunction regeneration converters.

◆ Connecting the MRS or MYS brake resistor or the FR-ABR high-duty brake resistor

It is recommended to configure a sequence, which shuts off power on the input side of the inverter by the external thermal relay as follows, to prevent overheat and burnout of the brake resistor (MRS, MYS) or the high-duty brake resistor (FR-ABR) in case the regenerative brake transistor is damaged. (A brake resistor cannot be connected to the FR-D820-0.1K-008, FR-D820-0.2K-014, FR-D820S-0.1K-008, FR-D820S-0.2K-014, FR-D810W-0.1K-008, and FR-D810W-0.2K-014.)

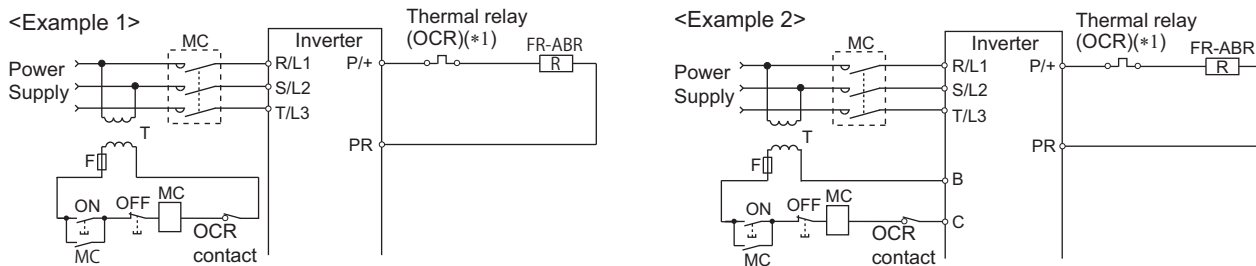

*1 Refer to the following table for the thermal relay models for each capacity. Refer to the following diagram for connection. (Always install a thermal relay when using a brake resistor for the inverters with 11K or higher capacity.)

Power supply voltage	Brake resistor	Thermal relay model (Mitsubishi Electric product)	Rated operating current
100 V/ 200 V	MRS120W200	TH-T25-0.7A	120 VAC: 2 A (NO contact) / 3 A (NC contact), 240 VAC: 1 A (NO contact) / 2 A (NC contact) (AC15 class) 110 VDC: 0.2 A, 220 VDC: 0.1 A (DC13 class)
	MRS120W100	TH-T25-1.3A	
	MRS120W60	TH-T25-2.1A	
	MRS120W40	TH-T25-3.6A	
	MYS220W50 (two in parallel)	TH-T25-5A	

Power supply voltage	High-duty brake resistor	Thermal relay model (Mitsubishi Electric product)	Rated operating current
100 V/ 200 V	FR-ABR-0.4K	TH-T25-0.7A	120 VAC: 2 A (NO contact) / 3 A (NC contact), 240 VAC: 1 A (NO contact) / 2 A (NC contact) (AC15 class) 110 VDC: 0.2 A, 220 VDC: 0.1 A (DC13 class)
	FR-ABR-0.75K	TH-T25-1.3A	
	FR-ABR-2.2K	TH-T25-2.1A	
	FR-ABR-3.7K	TH-T25-3.6A	
	FR-ABR-5.5K	TH-T25-5A	
	FR-ABR-7.5K	TH-T25-6.6A	
	FR-ABR-11K	TH-T25-11A	
	FR-ABR-15K		
400 V	FR-ABR-H0.4K	TH-T25-0.24A	
	FR-ABR-H0.75K	TH-T25-0.35A	
	FR-ABR-H1.5K	TH-T25-0.9A	
	FR-ABR-H2.2K	TH-T25-1.3A	
	FR-ABR-H3.7K	TH-T25-2.1A	
	FR-ABR-H5.5K	TH-T25-2.5A	
	FR-ABR-H7.5K	TH-T25-3.6A	
	FR-ABR-H11K	TH-T25-6.6A	
	FR-ABR-H15K		

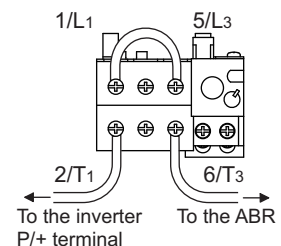

NOTE

- Do not use the brake resistor (MRS type, MYS type) with a lead wire extended.
- Do not connect a resistor to terminals P/+ and N/-. Doing so may cause a fire.

◆ Connection of a brake resistor other than the FR-ABR

Use a brake resistor that has resistance and power consumption values higher than the following. Also, the brake resistor must have a sufficient capacity to consume the regenerative power.

Voltage class	Inverter	Minimum resistance (Ω)	Power consumption (kW)
Three-phase 200 V class	FR-D820-0.4K-025 ^{*1}	100	1.5
	FR-D820-0.75K-042 ^{*1}	80	1.9
	FR-D820-1.5K-070	60	2.5
	FR-D820-2.2K-100	60	2.5
	FR-D820-3.7K-165	40	3.8
	FR-D820-5.5K-238	25	6.1
	FR-D820-7.5K-318	20	7.6
	FR-D820-11K-450	13	11.7
	FR-D820-15K-580	9	16.9
Three-phase 400 V class	FR-D840-0.4K-012	371	1.6
	FR-D840-0.75K-022	236	2.4
	FR-D840-1.5K-037	205	2.8
	FR-D840-2.2K-050	180	3.2
	FR-D840-3.7K-081	130	4.4
	FR-D840-5.5K-120	94	6.1
	FR-D840-7.5K-163	67	8.6
	FR-D840-11K-230	49	11.8
	FR-D840-15K-295	36	16.0
Single-phase 200 V class	FR-D820S-0.4K-025 ^{*1}	100	1.5
	FR-D820S-0.75K-042 ^{*1}	80	1.9
	FR-D820S-1.5K-070	60	2.5
	FR-D820S-2.2K-100	60	2.5
Single-phase 100 V class	FR-D810W-0.4K-025 ^{*1}	100	1.5
	FR-D810W-0.75K-042 ^{*1}	80	1.9

*1 The resistance should be 200 Ω or more at 100% ED. The following shows the brake duty when the resistance is less than 200 Ω.

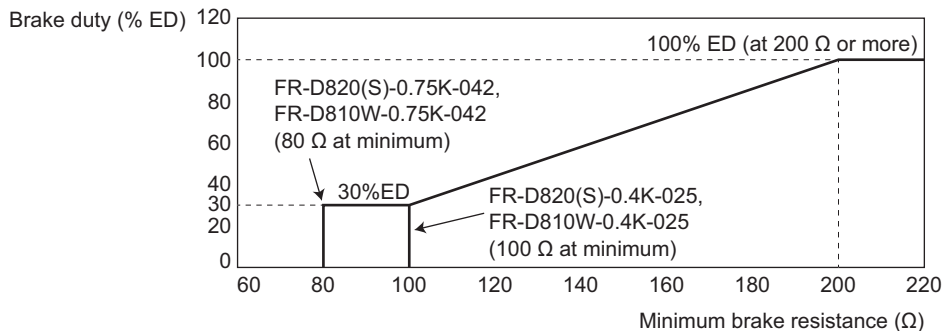

Set parameters as follows:

- **Pr.30 Regenerative function selection** = "1"
- Set **Pr.70 Special regenerative brake duty** according to the amount and frequency of the regenerative driving, and make sure that the resistor can consume the regenerative power properly. (Refer to the Instruction Manual (Function).)

- When the regenerative brake transistor is damaged, install a thermal relay as shown in the following sequence to prevent overheat and burnout of the brake resistor. Properly select a thermal relay according to the regenerative driving frequency or the rated power or resistance of the brake resistor.

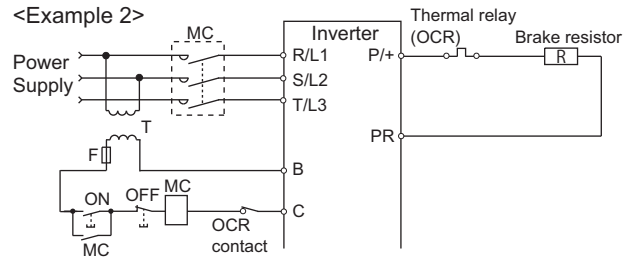
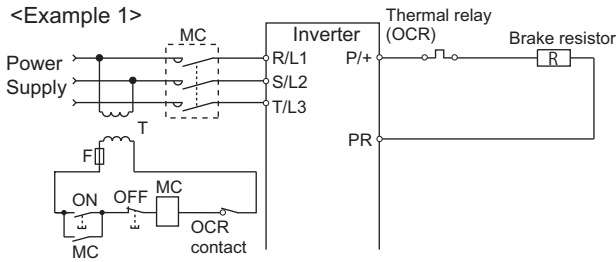

⚠ CAUTION

- If the resistor selection is incorrect, overcurrent may damage the inverter built-in brake transistor. Besides, the resistor may be burned due to overheat.
- If the selection of the thermal relay is incorrect, the resistor may be burned due to overheat.

2.8.2 Connection of the brake unit (FR-BU2(-H))

Connect the brake unit (FR-BU2(-H)) as follows to improve the braking capability during deceleration.

◆ Connection example with the GRZG type discharging resistor

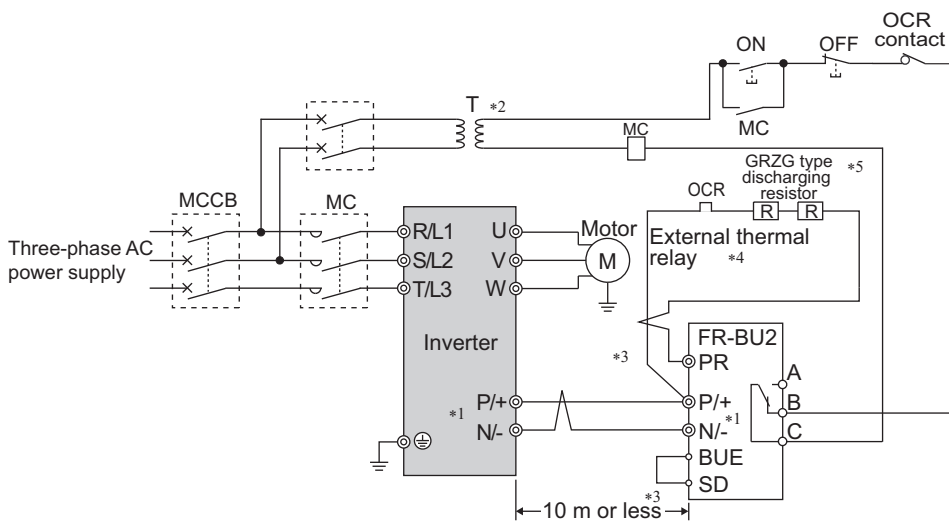

- *1 When wiring, make sure to match the terminal symbols (P/+, N/-) on the inverter and on the brake unit (FR-BU2). (Incorrect connection will damage the inverter and brake unit.)
- *2 When the power supply is 400 V class, install a stepdown transformer.
- *3 The wiring distance between the inverter, brake unit (FR-BU2) and discharging resistor must be within 5 m. When using twisted pair cable, use a cable that is 10 m or shorter.
- *4 It is recommended to install an external thermal relay to prevent overheat of the discharging resistor.
- *5 For the connection method of the discharging resistor, refer to the Instruction Manual of the FR-BU2.

- Recommended external thermal relay

brake unit	Discharging resistor	Recommended external thermal relay
FR-BU2-1.5K	GZG 300W-50Ω (one)	TH-T25 1.3A
FR-BU2-3.7K	GRZG 200-10Ω (three in series)	TH-T25 3.6A
FR-BU2-7.5K	GRZG 300-5Ω (four in series)	TH-T25 6.6A
FR-BU2-15K	GRZG 400-2Ω (six in series)	TH-T25 11A
FR-BU2-H7.5K	GRZG 200-10Ω (six in series)	TH-T25 3.6A
FR-BU2-H15K	GRZG 300-5Ω (eight in series)	TH-T25 6.6A
FR-BU2-H30K	GRZG 400-2Ω (twelve in series)	TH-T25 11A

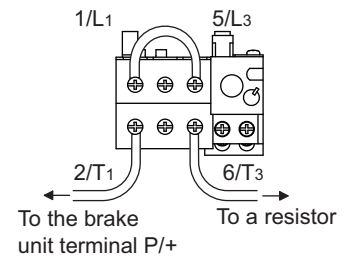

NOTE

- Set "1" in **Pr.0 Brake mode selection** in the FR-BU2 to use a GRZG type discharging resistor.
- Do not remove the jumper across terminals P/+ and P1 except when connecting a DC reactor (FR-HEL).

- *6 Do not install an MCCB or MC across terminals (R/L1, S/L2, T/L3) on the reactor 1 and terminals (R4/L14, S4/L24, T4/L34) on the FR-HC2. Doing so disrupts proper operation.
- *7 Securely perform grounding (earthing) by using the earth (ground) terminal.
- *8 Installation of a fuse is recommended. (Refer to the FR-HC2 Instruction Manual.)

NOTE

- The voltage phases of terminals R/L1, S/L2, and T/L3 and the voltage phases of terminals R4/L14, S4/L24, and T4/L34 must be matched.
- The control logic (sink logic/source logic) of the high power factor converter and the inverter must be matched. (Refer to page 62.)
- Do not connect a DC reactor (FR-HEL) to the inverter when the FR-HC2 is connected.

CAUTION

- Always connect terminal RDY on the FR-HC2 to a terminal where the X10 signal or MRS signal is assigned on the inverter. Always connect terminal SE on the FR-HC2 to terminal SD on the inverter. Not connecting these terminals may damage the FR-HC2.

2.8.4 Connection of the multifunction regeneration converter (FR-XC)

When connecting the multifunction regeneration converter (FR-XC) to improve the braking capability, perform wiring securely as follows. Failure to do so will damage the converter and the inverter.

Turn ON switch 1 in the function selection switch assembly (SW2). If the switch setting does not match the actual wiring, the connection mode fault "E.T" occurs. Set "0" in Pr.416 of the FR-XC converter.

After making sure that the wiring is correct and secure,

set "0 (initial value)" or "2" (when the automatic restart after instantaneous power failure is selected) in Pr.30 Regenerative function selection, and set "0" in Pr.70 Special regenerative brake duty. (Refer to the Instruction Manual (Function).)

◆ Common bus regeneration mode (Pr.416 = "0")

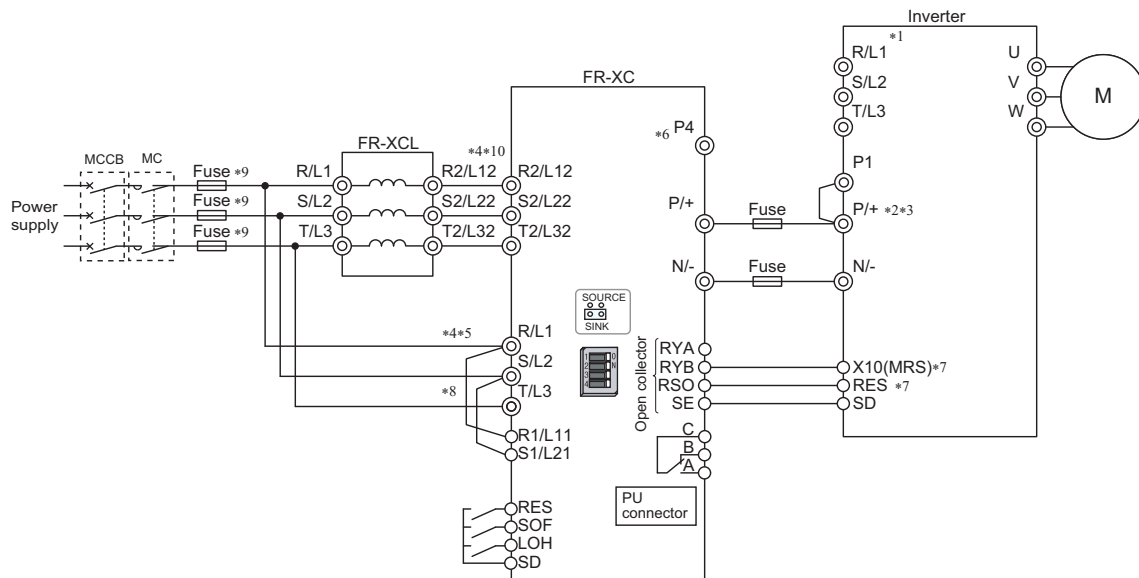

- *1 Never connect the power supply to terminals R/L1, S/L2, and T/L3 on the inverter. Doing so will damage the inverter and the converter.
- *2 When the FR-XC is connected, the jumper across terminals P/+ and P1 does not affect the function. (The FR-XC can be connected with the jumper connected.)
- *3 Connect between the inverter terminal P/+ and the converter terminal P/+ and between the inverter terminal N/- and the converter terminal N/- for polarity consistency. Failure to do so will damage the converter and the inverter.
- *4 Confirm the correct phase sequence of three-phase current to connect between the reactor and the converter, and between the power supply and terminals R/L1, S/L2, and T/L3. Failure to do so will damage the converter.
- *5 Be sure to connect the power supply and terminals R/L1, S/L2, and T/L3 of the converter. Operating the inverter without connecting them will damage the converter.
- *6 Do not connect anything to terminal P4.
- *7 Assign the X10 and RES signals to any of the input terminals.
- *8 To use separate power supply for the control circuit, remove each jumper at terminal R1/L11 and terminal S1/L21.

*9 Install UL listed fuses on the input side of the reactor to meet the UL/cUL standards (refer to the FR-XC Instruction Manual for information about the fuse).

*10 Do not install an MCCB or MC between the reactor and the converter. Doing so disrupts proper operation.

CAUTION

- In the common bus regeneration mode, always connect between the converter terminal RYB and the inverter terminal to which the X10 (MRS) signal is assigned and between the converter terminal SE and the inverter terminal SD. Failure to do so will damage the converter.

NOTE

- Configure a system so that the magnetic contactor at the converter input side shuts off the power supply at a failure of the converter or the connected inverter. (The converter does not shut off the power supply by itself.) Failure to do so may overheat and burn the resistors in the converter and the connected inverter.
- For details on model selection and connection, refer to the FR-XC Instruction Manual.
- For details on connection in harmonic suppression mode or in power regeneration mode 2, refer to the FR-XC Instruction Manual.

2.8.5 Connection of the AC reactor (FR-HAL)

- Keep the surrounding air temperature within the permissible range (-10°C to +50°C). Keep enough clearance around the reactor as it gets hot. (Take 10 cm or more clearance on top and bottom and 5 cm or more on left and right regardless of the installation direction.)

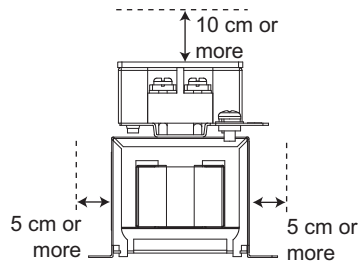

Three-phase power supply

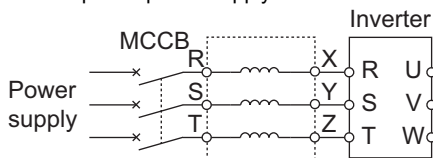

Single-phase power supply

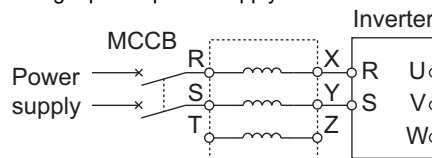

- For multiple inverters, an AC reactor (FR-HAL) should be installed per inverter. If one reactor is used for multiple inverters, the power factor improving effect will be insufficient unless all inverters are operated.

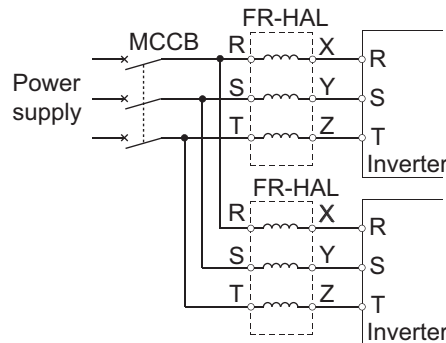

- Select an AC reactor according to the applied motor capacity. When using a motor with capacity lower than 0.4 kW, select the reactor for a 0.4 kW motor. For the single-phase 200 V power input models, select the reactor whose capacity is one rank higher than the motor capacity. (Refer to [page 107](#).) For the single-phase 100 V power input models, select the reactor whose capacity is three ranks higher than the motor capacity. (Refer to [page 110](#).)
- Securely perform grounding (earthing) by using the earth (ground) terminal.

NOTE

- As a reference, the cable gauge for the connection must be equal to or larger than that of the power cables (R/L1, S/L2, T/L3) and the earthing (grounding) cable. (Refer to [page 53](#).)

2.8.6 Connection of the DC reactor (FR-HEL)

- Keep the surrounding air temperature within the permissible range (-10°C to +50°C). Keep enough clearance around the reactor as it gets hot. (Take 10 cm or more clearance on top and bottom and 5 cm or more on left and right regardless of the installation direction.)

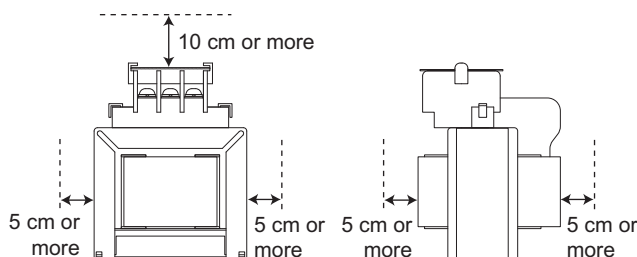

- When using the DC reactor (FR-HEL), connect it to terminals P/+ and P1.
- In this case, the jumper connected across terminals P/+ and P1 must be removed. Otherwise, the reactor will not be effective.

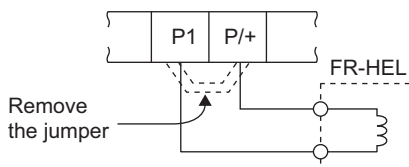

- Select a DC reactor according to the applied motor capacity. When using a motor with capacity lower than 0.4 kW, select the reactor for a 0.4 kW motor. For the single-phase 200 V power input models, select the reactor whose capacity is one rank higher than the motor capacity. (Refer to [page 107](#).)
- Since the DC reactor (FR-HEL) is electrically connected to the enclosure through mounting screws, the DC reactor is earthed (grounded) by being securely mounted to the enclosure. However, if the DC reactor is not earthed (grounded) securely enough, an earthing (grounding) cable may be used.
- For compliance with UL/cUL standards, EU Directive (CE marking) (EMC Directive and Low Voltage Directive), EAC certification, and UK certification scheme (UKCA marking), the inverter must be earthed (grounded) via the earth (ground) terminal.

NOTE

- The wiring distance must be within 5 m.
- For the size of the cables used, refer to [page 53](#).
- A DC reactor (FR-HEL) cannot be connected to the single-phase 100 V power input models.

3 Precautions for Use of the Inverter

This chapter explains the precautions for use of this product.
Always read the instructions before use.

3.1 Electro-magnetic interference (EMI) and leakage currents

3.1.1 Leakage currents and countermeasures

Capacitance exists between the inverter I/O cables, other cables and earth and in the motor, through which a leakage current flows. The amount of current leakage depends on the factors such as the size of the capacitance and the carrier frequency. Low acoustic noise operation at an increased carrier frequency of the inverter will increase current leakage. Take the following precautions to prevent current leakage. Earth leakage circuit breakers should be selected based on their rated current sensitivity, independently of the carrier frequency setting.

◆ To-earth (ground) leakage currents

Leakage currents may flow not only into the power system of the inverter but also into the other power systems through the earthing (grounding) cable, etc. These leakage currents may operate earth leakage circuit breakers and earth leakage relays unnecessarily.

■ Precautions

- If the carrier frequency setting is high, decrease the **Pr.72 PWM frequency selection** setting. Note that motor noise increases. Selecting **Pr.240 Soft-PWM operation selection** makes the sound inoffensive.
- By using earth leakage circuit breakers designed to suppress harmonics and surge voltage in the power system of the inverter and other power systems, operation can be performed with the carrier frequency kept high (with low noise).

NOTE

- Long wiring will increase the leakage current.
- High motor capacity will increase the leakage current. The leakage current of the 400 V class is larger than that of the 200 V class.

◆ Line-to-line leakage currents

Harmonics of leakage currents flowing in static capacitance between the inverter output cables may operate the external thermal relay unnecessarily. When the wiring length is long (50 m or more) for the 400 V class small-capacity models (FR-D840-7.5K-163 or lower), the external thermal relay is likely to operate unnecessarily because the ratio of the leakage current to the rated motor current increases.

■ Line-to-line leakage current example (200 V class)

Motor capacity (kW)	Rated motor current (A)	Leakage current (mA) ^{*1}		Condition
		Wiring length 50 m	Wiring length 100 m	
0.4	1.8	310	500	• Motor: SF-JR 4P • Carrier frequency: 14.5 kHz • Cable: 2 mm ² , 4 cores • Cabtyre cable
0.75	3.2	340	530	
1.5	5.8	370	560	
2.2	8.1	400	590	
3.7	12.8	440	630	
5.5	19.4	490	680	
7.5	25.6	535	725	

*1 The leakage currents of the 400 V class are about twice as large.

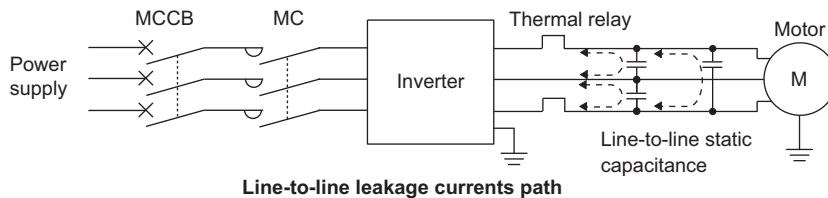

■ Precautions

- Use **Pr.9 Electronic thermal O/L relay**.
- If the carrier frequency setting is high, decrease the **Pr.72 PWM frequency selection** setting. Note that motor noise increases. Selecting **Pr.240 Soft-PWM operation selection** makes the sound inoffensive. To ensure that the motor is protected against line-to-line leakage currents, it is recommended to use a temperature sensor to directly detect motor temperature.

■ Installation and selection of the molded case circuit breaker

Install a molded case circuit breaker (MCCB) on the power receiving side to protect the wiring at the inverter input side. Select an MCCB according to the inverter input side power factor, which depends on the power supply voltage, output frequency and load. Especially for a completely electromagnetic MCCB, a slightly large capacity must be selected since its operation characteristic varies with harmonic currents. (Check it in the data of the corresponding breaker.) As an earth leakage current breaker, use the Mitsubishi earth leakage current breaker designed for harmonics and surge suppression.

◆ Selecting the rated sensitivity current for the earth leakage circuit breaker

To install the earth leakage circuit breaker on the inverter circuit, select its rated sensitivity current as follows, independently of the PWM carrier frequency.

- Breaker designed for harmonic and surge suppression
Rated sensitivity current
 $I_{\Delta n} \geq 10 \times (I_{g1} + I_{gn} + I_{gi} + I_{g2} + I_{gm})$
- Standard breaker
Rated sensitivity current
 $I_{\Delta n} \geq 10 \times \{I_{g1} + I_{gn} + I_{gi} + 3 \times (I_{g2} + I_{gm})\}$

- I_{g1}, I_{g2} : Leakage currents in wire path during commercial power supply operation
- I_{gn} : Leakage current from noise filters on the input side of the inverter
- I_{gm} : Leakage current from the motor during commercial power supply operation
- I_{gi} : Leakage current of inverter unit

Example of leakage current of cable path per 1 km during the commercial power supply operation when the CV cable is routed in metal conduit (200 V 60 Hz)

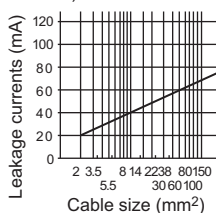

Leakage current example of three-phase induction motor during the commercial power supply operation (200 V 60 Hz)

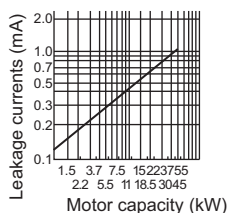

Example of leakage current of cable path per 1km during the commercial power supply operation when the CV cable is routed in metal conduit

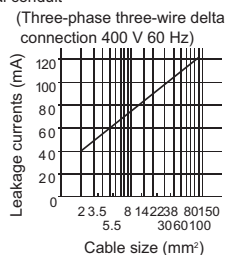

Leakage current example of three-phase induction motor during the commercial power supply operation

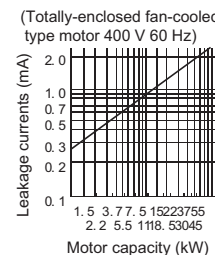

For "Δ" connection, the amount of leakage current is approx. 1/3 of the above value.

Example	Item	Breaker designed for harmonic and surge suppression	Standard breaker
	Leakage current I_{g1} (mA)	$33 \times \frac{5m}{1000m} = 0.17$	
	Leakage current I_{gn} (mA)	0 (without noise filter)	
	Leakage current I_{gi} (mA)	1 (without EMC filter)	
	Leakage current I_{g2} (mA)	$33 \times \frac{50m}{1000m} = 1.65$	
	Motor leakage current I_{gm} (mA)	0.18	
	Total leakage current (mA)	3.00	6.66
	Rated sensitivity current (mA) ($\geq I_g \times 10$)	30	100

NOTE

- Install the earth leakage circuit breaker (ELB) on the input side of the inverter.
- In the Δ connection earthed-neutral system, the sensitivity current is blunt against a ground fault in the inverter output side. Earthing (Grounding) must conform to the requirements of national and local safety regulations and electrical codes. (NEC section 250, IEC 61140 class 1 and other applicable standards)
- When the breaker is installed on the output side of the inverter, it may be unnecessarily operated by harmonics even if the effective value is within the rating.
- In this case, do not install the breaker since the eddy current and hysteresis loss will increase, leading to temperature rise.
- The following models and products are standard breakers: the models BV-C1, BC-V, NVB, NV-L, NV-G2N, NV-G3NA, and NV-2F, the earth leakage circuit breakers with AA neutral wire open-phase protection, and the earth leakage relays (except NV-ZHA).
The other series, models, and products are designed for harmonic and surge suppression: the NV-C series, NV-S series, MN series, the models NV30-FA, NV50-FA, BV-C2, earth leakage alarm breaker (NF-Z), NV-ZHA, and NV-H.

3.1.2 Techniques and measures for electromagnetic compatibility (EMC)

Some electromagnetic noises enter the inverter to cause the inverter malfunction, and others are radiated by the inverter to cause the peripheral devices to malfunction. (The former is called EMS problem, the latter is called EMI problem, and both is called EMC problem.) Though the inverter is designed to be immune to noises, it requires the following basic measures and EMS measures as it handles low-level signals. Pay attention to the electromagnetic noises that could be generated by the inverter since the inverter chops outputs at high carrier frequency. If these electromagnetic noises cause peripheral devices to malfunction, EMI countermeasures should be taken to suppress noises. These techniques differ slightly depending on EMI paths.

◆ Basic measures

- Do not run the power cables (I/O cables) and signal cables of the inverter in parallel with each other and do not bundle them.
- Use shielded twisted pair cables for the detector connecting and control signal cables and connect the sheathes of the shielded cables to terminal SD.
- Ground (Earth) the inverter, motor, etc. at one point.

◆ EMS measures to reduce electromagnetic noises that enter the inverter and cause it to malfunction

When devices that generate many electromagnetic noises (which use magnetic contactors, electromagnetic brakes, many relays, for example) are installed near the inverter and the inverter may malfunction due to electromagnetic noises, the following countermeasures must be taken:

- Provide surge suppressors for devices that generate many electromagnetic noises to suppress electromagnetic noises.
- Install data line filters to signal cables (refer to [page 92](#)).
- Ground (Earth) the shields of the detector connection and control signal cables with cable clamp metal.
- If affected by noise, earth (ground) the shielded part of the communication cable to the enclosure (as close as possible to the inverter) using a metal P-clip or U-clip to reduce noise on the communication cable.

◆ EMI measures to reduce electromagnetic noises that are radiated by the inverter to cause the peripheral devices to malfunction

Inverter-generated noises are largely classified into those radiated by the inverter itself and by the I/O cables connected to its main circuit, those electromagnetically and electrostatically induced to the signal cables of the peripheral devices close to the power cable connected to the inverter main circuit, and those transmitted through the power cables.

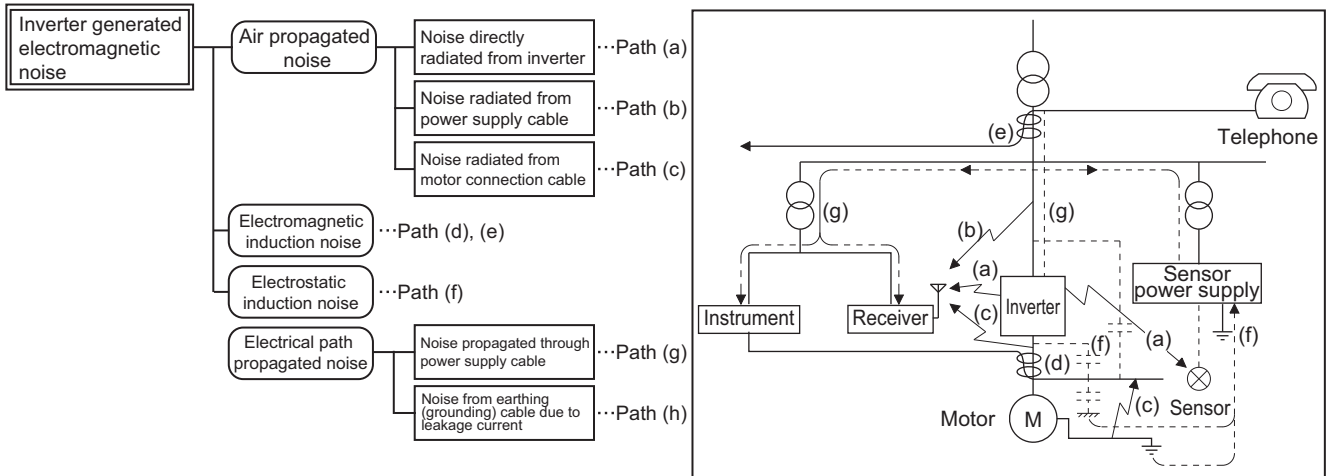

Noise propagation path	Countermeasure
(a), (b), (c)	<p>When devices that handle low-level signals and are liable to malfunction due to electromagnetic noises, e.g. instruments, receivers and sensors, are contained in the enclosure that contains the inverter or when their signal cables are run near the inverter, the devices may malfunction due to by air-propagated electromagnetic noises. The following countermeasures must be taken:</p> <ul style="list-style-type: none"> • Install easily affected devices as far away as possible from the inverter. • Run easily affected signal cables as far away as possible from the inverter and its I/O cables. • Do not run the signal cables and power cables (inverter I/O cables) in parallel with each other and do not bundle them. • Install an external EMC filter. • Install a line noise filter or radio noise filter on the input side and install a line noise filter on the output side to suppress the radiated noise from the cables. • Use shielded cables as signal cables and power cables and run them in individual metal conduits to produce further effects.
(d), (e), (f)	<p>When the signal cables are run in parallel with or bundled with the power cables, magnetic and static induction noises may be propagated to the signal cables to cause malfunction of the devices and the following countermeasures must be taken:</p> <ul style="list-style-type: none"> • Install easily affected devices as far away as possible from the inverter. • Run easily affected signal cables as far away as possible from the inverter and its I/O cables. • Do not run the signal cables and power cables (inverter I/O cables) in parallel with each other and do not bundle them. • Use shielded cables as signal cables and power cables and run them in individual metal conduits to produce further effects.
(g)	<p>When the power supplies of the peripheral devices are connected to the power supply of the inverter in the same power system, inverter-generated noises may flow back through the power supply cables to cause malfunction of the devices and the following countermeasures must be taken:</p> <ul style="list-style-type: none"> • Install an external EMC filter. • Install the line noise filter (FR-BLF/FR-BSF01) on the power cables (output cables) of the inverter.
(h)	<p>When a closed loop circuit is formed by connecting the peripheral device wiring to the inverter, leakage currents may flow through the earthing (grounding) cable of the inverter to cause the device to malfunction. In that case, disconnecting the earthing (grounding) cable from the device may stop the malfunction of the device.</p>

■ Data line filter

Data line filter is effective as an EMI countermeasure. Provide a data line filter for the detector cable, etc.

- Commercially available data line filter: ZCAT3035-1330 (by TDK), ESD-SR-250 (by TOKIN)
- Specification example (ZCAT3035-1330 by TDK)

Item	Description	
Impedance (Ω)	10 to 100 MHz	80
	100 to 500 MHz	150
Outline dimension drawings (mm)		

The impedance values above are reference values, and not guaranteed values.

■ EMI measure example

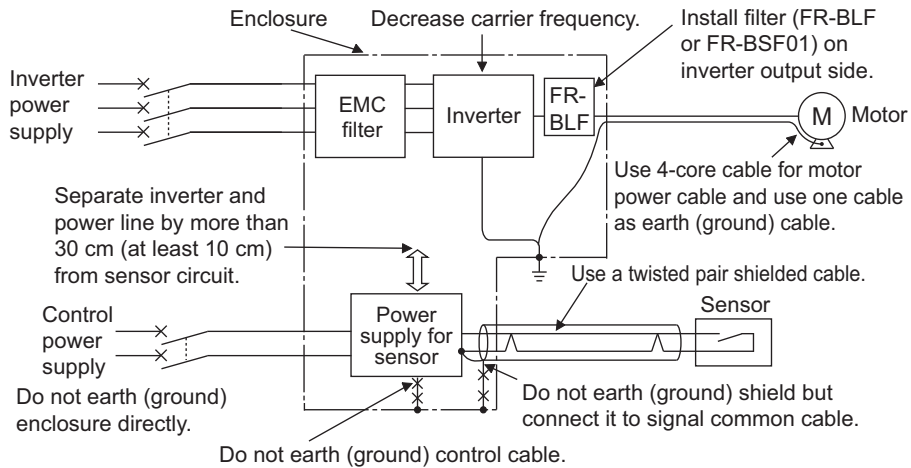

NOTE

- For compliance with the EU EMC Directive, refer to the document enclosed with the product.

3.2 Power supply harmonics

3.2.1 Power supply harmonics

The inverter may generate power supply harmonics from its converter circuit to affect the power generator, power factor correction capacitor etc. Power supply harmonics are different from noise and leakage currents in source, frequency band and transmission path. Take the following countermeasures.

- Differences between harmonics and noises

Item	Harmonics	Noise
frequency	Normally 40th to 50th degrees or less (3 kHz or less).	High frequency (several 10 kHz to 1 GHz order).
Location	To-electric channel, power impedance.	To-space, distance, wiring path.
Quantitative understanding	Theoretical calculation possible.	Random occurrence, quantitative grasping difficult.
Generated amount	Nearly proportional to the load capacity.	Changes with the current variation ratio. (Gets larger as switching speed increases.)
Affected equipment immunity	Specified by standards per equipment.	Different depending on maker's equipment specifications.
Countermeasure	Provide a reactor.	Increase distance.

- Countermeasures

The harmonic current generated from the inverter to the input side differs according to various conditions such as the wiring impedance, whether a reactor is used or not, and output frequency and output current on the load side.

For the output frequency and output current, we understand that this should be calculated in the conditions under the rated load at the maximum operating frequency.

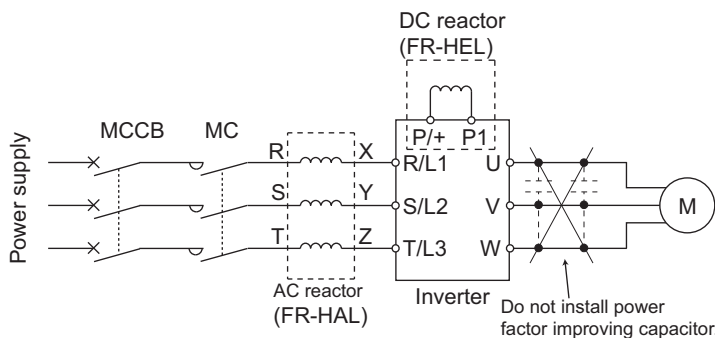

NOTE

- The power factor improving capacitor and surge suppressor on the inverter output side may be overheated or damaged by the harmonic components of the inverter output. Also, since an excessive current flows in the inverter to activate overcurrent protection, do not provide a capacitor and surge suppressor on the inverter output side when the motor is driven by the inverter. For power factor improvement, install a reactor on the inverter input side or in the DC circuit.

3.2.2 Harmonic suppression guidelines in Japan

Inverters have a converter section (rectifier circuit) and generate a harmonic current.

Harmonic currents flow from the inverter to a power receiving point via a power transformer. The Harmonic Suppression Guidelines was established to protect other consumers from these outgoing harmonic currents.

The three-phase 200 V input specifications 3.7 kW or lower (or single-phase 200 V input specifications 2.2 kW or lower and single-phase 100 V input specifications 0.75 kW or lower) were previously covered by the Harmonic Suppression Guidelines for Household Appliances and General-purpose Products and other models were covered by the Harmonic Suppression Guidelines for Consumers Who Receive High Voltage or Special High Voltage. However, the transistorized inverter has been excluded from the target products covered by the Harmonic Suppression Guidelines for Household Appliances and General-

purpose Products in January 2004 and the Harmonic Suppression Guideline for Household Appliances and General-purpose Products was repealed on September 6, 2004.

All capacity and all models of general-purpose inverter used by specific consumers are now covered by "the Harmonic Suppression Guidelines for Consumers Who Receive High Voltage or Special High Voltage" (hereinafter referred to as "the Specific Consumer Guidelines").

- "Specific Consumer Guidelines"
- This guideline sets forth the maximum harmonic currents outgoing from a high-voltage or especially high-voltage receiving consumer who will install, add or renew harmonic generating equipment. If any of the maximum values is exceeded, this guideline requires that consumer to take certain suppression measures.
- Maximum values of outgoing harmonic currents per 1 kW contract power

Received power voltage	5th	7th	11th	13th	17th	19th	23rd	Over 23rd
6.6 kV	3.5	2.5	1.6	1.3	1.0	0.9	0.76	0.70
22 kV	1.8	1.3	0.82	0.69	0.53	0.47	0.39	0.36
33 kV	1.2	0.86	0.55	0.46	0.35	0.32	0.26	0.24

◆ Application of the specific consumer guidelines

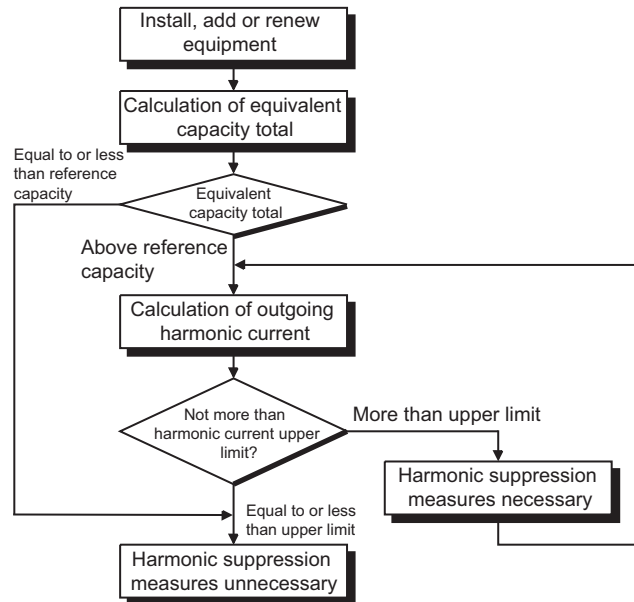

■ Conversion factor

Classification	Circuit type		Conversion factor Ki
3	Three-phase bridge (capacitor smoothing)	Without reactor	K31 = 3.4
		With reactor (AC side)	K32 = 1.8
		With reactor (DC side)	K33 = 1.8
		With reactors (AC, DC sides)	K34 = 1.4
4	Single-phase bridge (capacitor smoothing, double voltage rectification)	Without reactor	K41 = 2.3
		With reactor (AC side)	K42 = 0.35
	Single-phase bridge (capacitor smoothing, full-wave rectification)	Without reactor	K43 = 2.9
		With reactor (AC side)	K44 = 1.3
5	Self-excitation three-phase bridge	When a high power factor converter is used	K5 = 0

■ Equivalent capacity limit

Received power voltage	Reference capacity
6.6 kV	50 kVA
22/33 kV	300 kVA
66 kV or more	2000 kVA

■ Harmonic content (when the fundamental current is considered as 100%)

	Reactor	5th	7th	11th	13th	17th	19th	23rd	25th
Three-phase bridge (capacitor smoothing)	Not used	65	41	8.5	7.7	4.3	3.1	2.6	1.8
	Used (AC side)	38	14.5	7.4	3.4	3.2	1.9	1.7	1.3
	Used (DC side)	30	13	8.4	5.0	4.7	3.2	3.0	2.2
	Used (AC, DC sides)	28	9.1	7.2	4.1	3.2	2.4	1.6	1.4
Single-phase bridge (capacitor smoothing, double voltage rectification)	Not used	50	24	5.1	4.0	1.5	1.4	—	—
	Used (AC side)	6.0	3.9	1.6	1.2	0.6	0.1	—	—
Single-phase bridge (capacitor smoothing, full-wave rectification)	Not used	60	33.5	6.1	6.4	2.6	2.7	1.5	1.5
	Used (AC side)	31.9	8.3	3.8	3.0	1.7	1.4	1.0	0.7

■ Calculation of equivalent capacity P₀ of harmonic generating equipment

"Equivalent capacity" is the capacity of a 6-pulse converter converted from the capacity of consumer's harmonic generating equipment and is calculated by the following equation. If the sum of equivalent capacities is higher than the limit (refer to the list of the equivalent capacity limits), harmonics must be calculated by the equation in next subheading.

$$P_0 = \sum (K_i \times P_i) \text{ [kVA]}$$

K_i: Conversion factor (Refer to the list of the conversion factors.)

P_i: Rated capacity of harmonic generating equipment^{*1} [kVA]

i: Number indicating the conversion circuit type

*1 Rated capacity: Determined by the capacity of the applied motor and found in the table "Rated capacities and outgoing harmonic currents of inverter-driven motors". The rated capacity used here is used to calculate the generated harmonic amount and is different from the power supply capacity required for actual inverter drive.

■ Calculation of outgoing harmonic current

Outgoing harmonic current = fundamental wave current (value converted from received power voltage) × operation ratio × harmonic content

• Operation ratio: actual load factor × operation time ratio during 30 minutes

• Harmonic content: Refer to the list of the harmonic content.

■ Rated capacities and outgoing harmonic currents of inverter-driven motors

Applicable motor (kW)	Fundamental wave current (A)		Fundamental wave current converted from 6.6 kV (mA)	Rated capacity (kVA)	Outgoing harmonic current converted from 6.6 kV (mA) (No reactor, 100% operation ratio)							
	200 V	400 V			5th	7th	11th	13th	17th	19th	23rd	25th
0.4	1.61	0.81	49	0.57	31.85	20.09	4.165	3.773	2.107	1.519	1.274	0.882
0.75	2.74	1.37	83	0.97	53.95	34.03	7.055	6.391	3.569	2.573	2.158	1.494
1.5	5.50	2.75	167	1.95	108.6	68.47	14.20	12.86	7.181	5.177	4.342	3.006
2.2	7.93	3.96	240	2.81	156.0	98.40	20.40	18.48	10.32	7.440	6.240	4.320
3.7	13.0	6.50	394	4.61	257.1	161.5	33.49	30.34	16.94	12.21	10.24	7.092
5.5	19.1	9.55	579	6.77	376.1	237.4	49.22	44.58	24.90	17.95	15.05	10.42
7.5	25.6	12.8	776	9.07	504.4	318.2	65.96	59.75	33.37	24.06	20.18	13.97
11	36.9	18.5	1121	13.1	728.7	459.6	95.29	86.32	48.20	34.75	29.15	20.18
15	49.8	24.9	1509	17.6	980.9	618.7	128.3	116.2	64.89	46.78	39.24	27.16

■ Determining if a countermeasure is required

A countermeasure for harmonics is required if the following condition is satisfied: outgoing harmonic current > maximum value per 1 kW contract power × contract power.

■ Harmonic suppression techniques

No.	Item	Description
1	Reactor installation (FR-HAL, FR-HEL ^{*1})	Install an AC reactor (FR-HAL) on the AC side of the inverter or a DC reactor (FR-HEL) on its DC side, or install both to suppress outgoing harmonic currents.
2	High power factor converter (FR-HC2), multifunction regeneration converter (FR-XC)	These converters trim the current waveform to be a sine waveform by switching the rectifier circuit (converter module) with transistors. Doing so suppresses the generated harmonic amount significantly. Connect it to the DC area of an inverter. Use the high power factor converter (FR-HC2) with the accessories that come as standard. To use the FR-XC series converter, use the converter with an FR-XCB box-type reactor and enable the harmonic suppression function.
3	Installation of power factor improving capacitor	When used with a reactor connected in series, the power factor improving correction capacitor can absorb harmonic currents.
4	Transformer multi-phase operation	Use two transformers with a phase angle difference of 30° in combinations of λ to Δ and Δ to Δ , to provide an effect corresponding to 12 pulses, reducing low-degree harmonic currents.
5	Passive filter (AC filter)	A capacitor and a reactor are used together to reduce impedances at specific frequencies. Harmonic currents are expected to be absorbed greatly by using this technique.
6	Active filter	This filter detects the current in a circuit generating a harmonic current and generates a harmonic current equivalent to a difference between that current and a fundamental wave current to suppress the harmonic current at the detection point. Harmonic currents are expected to be absorbed greatly by using this technique.

*1 A DC reactor (FR-HEL) cannot be connected to the single-phase 100 V power input models.

3.3 Installation of a reactor

When the inverter is connected near a large-capacity power transformer (500 kVA or more) or when a power factor correction capacitor is to be switched over, an excessive peak current may flow in the power input circuit, damaging the converter circuit. To prevent this, always install an AC reactor (FR-HAL), which is available as an option. Select a reactor according to the applied motor capacity. When using a motor with capacity lower than 0.4 kW, select the reactor for a 0.4kW motor. For the single-phase 200 V power input models, select the reactor whose capacity is one rank higher than the motor capacity. When connecting a single-phase 100 V power input model to power transformer (exceeding 50 kVA), install an AC reactor (FR-HAL) so that the performance is more reliable.

The following table shows the combinations of the single-phase 100 V power input model and AC reactor.

Inverter model	AC reactor (FR-HAL-□)
FR-D810W-0.1K-008	0.75K ^{*1}
FR-D810W-0.2K-014	1.5K ^{*1}
FR-D810W-0.4K-025	2.2K ^{*1}
FR-D810W-0.75K-042	3.7K ^{*1}

*1 The power factor may be slightly lower.

- Three-phase power input

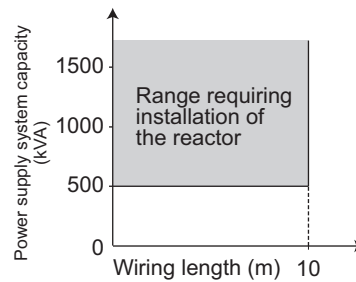
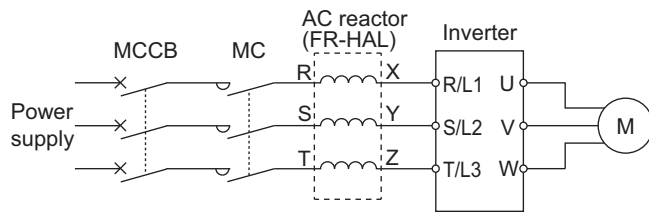

- Single-phase power input

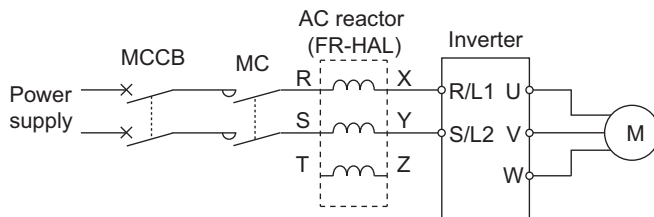

3.4 Power shutdown and magnetic contactor (MC)

◆ Inverter input side magnetic contactor (MC)

On the inverter input side, it is recommended to provide an MC for the following purposes. (Refer to [page 19](#) for selection.)

- To disconnect the inverter from the power supply at activation of a protective function or at malfunctioning of the driving system (emergency stop, etc.). For example, an MC prevents overheat or burnout of the brake resistor when heat capacity of the resistor is insufficient or brake regenerative transistor is damaged with short while connecting an optional brake resistor.
- To prevent any accident due to an automatic restart at power restoration after an inverter stop made by a power failure.
- To separate the inverter from the power supply to ensure safe maintenance and inspection work. Use the inverter input current as a reference for selection of an MC to perform an emergency stop during operation, and select the MC conforming to JEM 1038-AC-3 class rated operational current.

NOTE

- Since repeated inrush currents at power ON will shorten the life of the converter circuit (switching life is about 1,000,000 times), frequent starts and stops of the magnetic contactor must be avoided. Turn ON or OFF the start (STF/STR) signal for the inverter start control to run or stop the inverter.

• Inverter start/stop circuit example

As shown in the following figure, always use the start signal (turn ON or OFF the STF/STR signal) to make a start or stop.

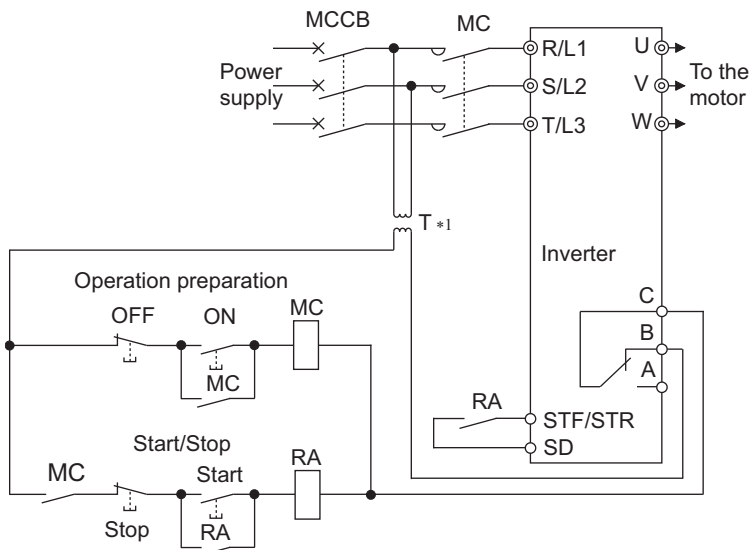

*1 When the power supply is 400 V class, install a stepdown transformer.

◆ Handling of the magnetic contactor on the inverter's output side

Switch the magnetic contactor between the inverter and motor only when both the inverter and motor are at a stop. When the magnetic contactor is turned ON while the inverter is operating, overcurrent protection of the inverter and such will activate.

◆ Handling of the manual contactor on the inverter's output side

A PM motor is a synchronous motor with high-performance magnets embedded inside. High-voltage is generated at the motor terminals while the motor is running even after the inverter power is turned OFF. In an application where the PM motor is driven by the load even after the inverter is powered OFF, a low-voltage manual contactor must be connected at the inverter's output side.

 **NOTE**

- Before wiring or inspection for a PM motor, confirm that the PM motor is stopped. In an application, such as fan and blower, where the motor is driven by the load, a low-voltage manual contactor must be connected at the inverter's output side, and wiring and inspection must be performed while the contactor is open. Otherwise you may get an electric shock.
- Do not open or close the contactor while the inverter is running (outputting).

3.5 Countermeasures against deterioration of the 400 V class motor insulation

In the PWM type inverter, a surge voltage attributable to wiring constants is generated at the motor terminals. Especially in a 400 V class motor, the surge voltage may deteriorate the insulation. When the 400 V class motor is driven by the inverter, consider the following countermeasures:

◆ Countermeasures

It is recommended to take one of the following countermeasures:

■ Rectifying the motor insulation and limiting the PWM carrier frequency according to the wiring length

For the 400 V class motor, use an insulation-enhanced motor.

Specifically,

- Order a "400 V class inverter-driven insulation-enhanced motor".
- For the dedicated motor such as the constant-torque motor and low-vibration motor, use an "inverter-driven dedicated motor".
- Set **Pr.72 PWM frequency selection** as indicated below according to the wiring length.

	Wiring length		
	Shorter than 50 m	50 to 100 m	Longer than 100 m
Pr.72 PWM frequency selection	14.5 kHz or less	8 kHz or less	2 kHz or less

■ Suppressing the surge voltage on the inverter side

- Connect the surge voltage suppression filter (FR-ASF-H/FR-BMF-H) to the output side of the inverter.

NOTE

- For details on the surge voltage suppression filter (FR-ASF-H/FR-BMF-H), refer to the Instruction Manual of each option.

3.6 Checklist before starting operation

The FR-D800 series inverter is a highly reliable product, but incorrect peripheral circuit making or operation/handling method may shorten the product life or damage the product. Before starting operation, always recheck the following points.

Checkpoint	Countermeasure	Refer to page	Check by user
Crimp terminals are insulated.	Use crimp terminals with insulation sleeves to wire the power supply and the motor.	—	
The wiring between the power supply (terminals R/L1, S/L2, T/L3) and the motor (terminals U, V, W) is correct.	Application of power to the output terminals (U, V, W) of the inverter will damage the inverter. Never perform such wiring.	50	
No wire offcuts are left from the time of wiring.	Wire offcuts can cause a fault, failure, or malfunction. Always keep the inverter clean. When drilling mounting holes in an enclosure etc., take caution not to allow chips and other foreign matter to enter the inverter.	—	
The main circuit cable gauge is correctly selected.	Use an appropriate cable gauge to suppress the voltage drop to 2% or less. If the wiring distance is long between the inverter and motor, a voltage drop in the main circuit will cause the motor torque to decrease especially during the output of a low frequency.	53	
The total wiring length is within the specified length.	Keep the total wiring length within the specified length. In long distance wiring, charging currents due to stray capacitance in the wiring may degrade the fast-response current limit operation or cause the equipment on the inverter's output side to malfunction. Pay attention to the total wiring length.	53	
Countermeasures are taken against EMI.	The input/output (main circuit) of the inverter includes high frequency components, which may interfere with the communication devices (such as AM radios) used near the inverter. Connect radio noise filters or EMC filters on the input side of the inverter to minimize interference.	90	
On the inverter's output side, there is no power factor correction capacitor, surge suppressor, or radio noise filter installed.	Doing so will shut off the inverter output or damage the capacitor or surge suppressor. If any of the above devices is connected, immediately remove it.	—	
When performing an inspection or rewiring on the product that has been energized, the operator has waited long enough after shutting off the power supply.	For a short time after the power-OFF, a high voltage remains in the smoothing capacitor, and it is dangerous. Before performing an inspection or rewiring, wait 10 minutes or longer after the power supply turns OFF, then confirm that the voltage across the main circuit terminals P/+ and N/- of the inverter is low enough using a digital multimeter, etc.	—	
The inverter's output side has no short circuit or ground fault occurring.	<ul style="list-style-type: none"> • A short circuit or ground fault on the inverter's output side may damage the inverter module. • Fully check the insulation resistance of the circuit prior to inverter operation since repeated short circuits caused by peripheral circuit inadequacy or an earth (ground) fault caused by wiring inadequacy or reduced motor insulation resistance may damage the inverter module. • Fully check the to-earth (ground) insulation and phase-to-phase insulation of the inverter's output side before power-ON. Especially for an old motor or use in hostile atmosphere, securely check the motor insulation resistance, etc. 	—	
The circuit is not configured to use the inverter's input-side magnetic contactor to start/stop the inverter frequently.	Since repeated inrush currents at power ON will shorten the life of the converter circuit, frequent starts and stops of the magnetic contactor must be avoided. Turn ON or OFF the inverter's start (STF/STR) signal to run or stop the inverter.	98	
A mechanical brake is not connected to terminals P/+ and PR.	To terminals P/+ and PR, connect only an external brake resistor.	78	
The voltage applied to the inverter I/O signal circuits is within the specifications.	Application of a voltage higher than the permissible voltage to the inverter I/O signal circuits or opposite polarity may damage the I/O devices.	59	

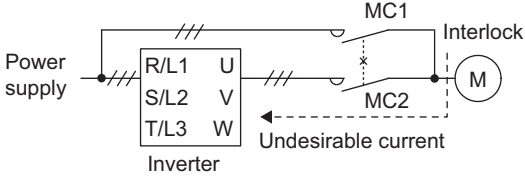
Checkpoint	Countermeasure	Refer to page	Check by user
<p>When using the electronic bypass operation, electrical and mechanical interlocks are provided between the electronic bypass contactors MC1 and MC2.</p>	<p>When using a switching circuit as shown below, chattering due to misconfigured sequence or arc generated at switching may allow undesirable current to flow in and damage the inverter. Miswiring may also damage the inverter. (Note that a PM motor cannot be driven by the commercial power supply.)</p>  <p>If switching to the commercial power supply operation while a failure such as an output short circuit has occurred between the magnetic contactor MC2 and the motor, the damage may spread further. If a failure has occurred between the MC2 and the motor, a protection circuit such as using the OH signal input must be provided.</p>	—	
<p>A countermeasure is provided for power restoration after a power failure.</p>	<p>If the machine must not be restarted when power is restored after a power failure, provide an MC on the inverter's input side and also make up a sequence which will not switch ON the start signal. If the start signal (start switch) remains ON after a power failure, the inverter will automatically restart as soon as the power is restored.</p>	—	
<p>A magnetic contactor (MC) is installed on the inverter's input side.</p>	<p>On the inverter's input side, connect an MC for the following purposes:</p> <ul style="list-style-type: none"> • To disconnect the inverter from the power supply at activation of a protective function or at malfunctioning of the driving system (emergency stop, etc.). • To prevent any accident due to an automatic restart at power restoration after an inverter stop made by a power failure. • To separate the inverter from the power supply to ensure safe maintenance and inspection work. <p>Use the inverter input current as a reference for selection of an MC to perform an emergency stop during operation, and select the MC conforming to JEM 1038-AC-3 class rated operational current.</p>	98	
<p>The magnetic contactor on the inverter's output side is properly handled.</p>	<p>Switch the magnetic contactor between the inverter and motor only when both the inverter and motor are at a stop.</p>	98	
<p>When using a PM motor, a low-voltage manual contactor is installed on the inverter's output side.</p>	<p>A PM motor is a synchronous motor with high-performance magnets embedded inside. High-voltage is generated at the motor terminals while the motor is running even after the inverter power is turned OFF. In an application, such as fan and blower, where the motor is driven by the load, a low-voltage manual contactor must be connected on the inverter's output side, and wiring and inspection must be performed while the contactor is open. Otherwise you may get an electric shock.</p>	98	
<p>An EMI countermeasure is provided for the frequency setting signals.</p>	<p>If electromagnetic noise generated from the inverter causes the frequency setting signal to fluctuate and the motor rotation speed to be unstable when changing the motor speed with analog signals, the following countermeasures are effective:</p> <ul style="list-style-type: none"> • Do not run the signal cables and power cables (inverter I/O cables) in parallel with each other and do not bundle them. • Run the signal cables as far away as possible from the power cables (inverter I/O cables). • Use shielded cables. • Install a data line filter to signal cable (example: ZCAT3035-1330 by TDK). 	90	
<p>A countermeasure is provided for an overload operation.</p>	<p>When performing frequent starts/stops by the inverter, rise/fall in the temperature of the transistor element of the inverter will repeat due to a repeated flow of large current, shortening the life from thermal fatigue. Since thermal fatigue is related to the amount of current, the life can be increased by reducing current at locked condition, starting current, etc. Reducing current may extend the service life but may also cause torque shortage, which leads to a start failure. Adding a margin to the current can eliminate such a condition. For an induction motor, use an inverter of a higher capacity (up to two ranks). For a PM motor, use an inverter and PM motor of higher capacities.</p>	—	
<p>The specifications and rating match the system requirements.</p>	<p>Make sure that the specifications and rating match the system requirements.</p>	107	

Checkpoint	Countermeasure	Refer to page	Check by user
Countermeasures are taken against electrical corrosion on the motor bearing.	<p>When a motor is driven by the inverter, axial voltage is generated on the motor shaft, which may cause electrical corrosion of the bearing in rare cases depending on the wiring, load, operating conditions of the motor or specific inverter settings (high carrier frequency). Contact your sales representative to take appropriate countermeasures for the motor. The following shows examples of countermeasures for the inverter.</p> <ul style="list-style-type: none"> • Decrease the carrier frequency. • Provide a common mode choke ^{*1} on the output side of the inverter. 	—	

*1 Our recommended common mode choke is FT-3KM F series FINEMET® common mode choke core which is manufactured by Proterial, Ltd. FINEMET is a registered trademark of Proterial, Ltd.

3.7 Failsafe system which uses the inverter

When a fault is detected by the protective function, the protective function activates and outputs the Fault signal. However, the Fault signal may not be output at an inverter's fault occurrence when the detection circuit or output circuit fails, etc. Although Mitsubishi assures the best quality products, provide an interlock which uses inverter status output signals to prevent accidents such as damage to the machine when the inverter fails for some reason. Also at the same time consider the system configuration where a failsafe from outside the inverter, without using the inverter, is enabled even if the inverter fails.

◆ Interlock method which uses the inverter status output signals

By combining the inverter output signals to provide an interlock as shown in the following table, an inverter failure can be detected. (For details of each signal, refer to the Instruction Manual (Function).)

No.	Interlock method	Check method	Used signals
a	Inverter protective function operation	Operation check of an alarm contact. Circuit error detection by negative logic.	Fault (ALM) signal
b	Inverter operating status	Operation ready signal check.	Inverter operation ready (RY) signal
c	Inverter running status	Logic check of the start signal and running signal.	Start (STF or STR) signal Inverter running (RUN) signal
d	Inverter running status ^{*1}	Logic check of the start signal and output current.	Start (STF or STR) signal Output current detection (Y12) signal

*1 This interlock method cannot be used when a PM motor is used.

- When using various signals, assign the functions to **Pr.190 to Pr.196 (Output terminal function selection)** referring to the following table.

Output signal	Pr.190 to Pr.196 settings	
	Positive logic	Negative logic
ALM	99	199
RY	11	111
RUN	0	100
Y12	12	112

NOTE

- Changing the terminal assignment using **Pr.190 to Pr.196 (Output terminal function selection)** may affect the other functions. Set parameters after confirming the function of each terminal.

■ Checking by using the fault signal output from the inverter ... (a)

When the inverter's protective function is activated and the inverter output is stopped, the Fault (ALM) signal is output. (The ALM signal is assigned to terminals A, B, and C in the initial setting). With this signal, check that the inverter operates properly. In addition, negative logic can be set. (ON when the inverter is normal, OFF when the fault occurs.)

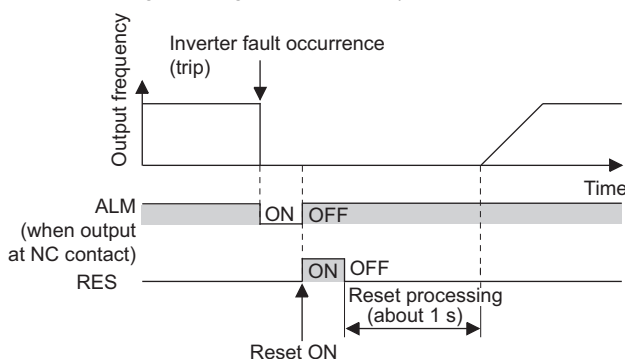

■ Checking the inverter operating status by using the Inverter operation ready signal output from the inverter ... (b)

The Inverter operation ready (RY) signal is output when the inverter power is ON and the inverter becomes operative. Check if the RY signal is output after powering ON the inverter.

■ Checking the inverter operating status by using the start signal input to the inverter and the Inverter running signal output from the inverter ... (c)

The Inverter running (RUN) signal is output when the inverter is running. Check if the RUN signal is output while a start signal (the STF/STR signal for forward/reverse rotation command) is input to the inverter. Even after the start signal is turned OFF, the RUN signal is kept output until the inverter makes the motor to decelerate and to stop. For the logic check, configure a sequence considering the inverter's deceleration time.

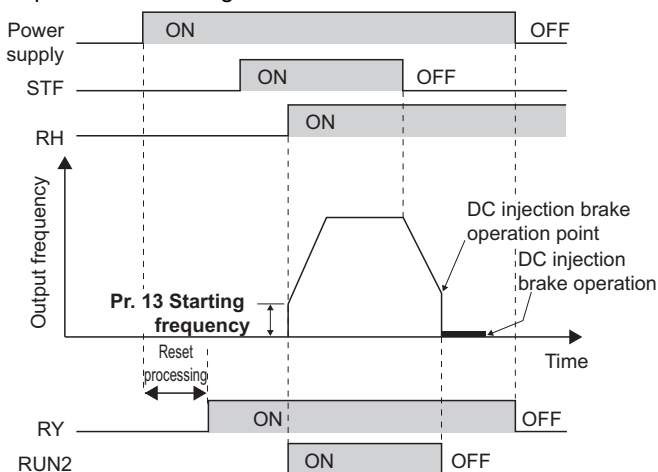

■ Checking the motor operating status by using the start signal input to the inverter and the Output current detection signal output from the inverter ... (d)

This interlock method cannot be used when a PM motor is used.

The Output current detection (Y12) signal is output when the inverter operates and current flows into the motor.

Check if the Y12 signal is output while a start signal (the STF/STR signal for forward/reverse rotation command) is input to the inverter. The Y12 signal is initially set to be output at 150% inverter rated current. Adjust the level to around 20% using no load current of the motor as reference with **Pr.150 Output current detection level**.

Like the Inverter running (RUN) signal, even after the start signal is turned OFF, the Y12 signal is kept output until the inverter makes the motor decelerate and stop. For the logic check, configure a sequence considering the inverter's deceleration time.

◆ Backup method which does not use the inverter

Even if the interlock is provided by the inverter status signal, enough failsafe is not ensured depending on the failure status of the inverter itself. For example, if an inverter CPU fails in a system interlocked with the inverter's fault, start, and RUN signals, no Fault signals will be output and the RUN signal will be kept ON because the inverter CPU is down.

Provide a speed detector to detect the motor speed and current detector to detect the motor current, and consider the backup system such as performing a check as follows according to the level of importance of the system.

■ Start signal and actual operation check

Check the motor running and motor current while the start signal is input to the inverter by comparing the start signal to the inverter and detected speed of the speed detector or detected current of the current detector. Note that the current is flowing through the motor while the motor coasts to stop, even after the inverter's start signal is turned OFF. For the logic check, configure a sequence considering the inverter's deceleration time. In addition, it is recommended to check the three-phase current when using the current detector.

■ Command speed and actual operation check

Check for a gap between the actual speed and commanded speed by comparing the inverter's speed command and the speed detected by the speed detector.

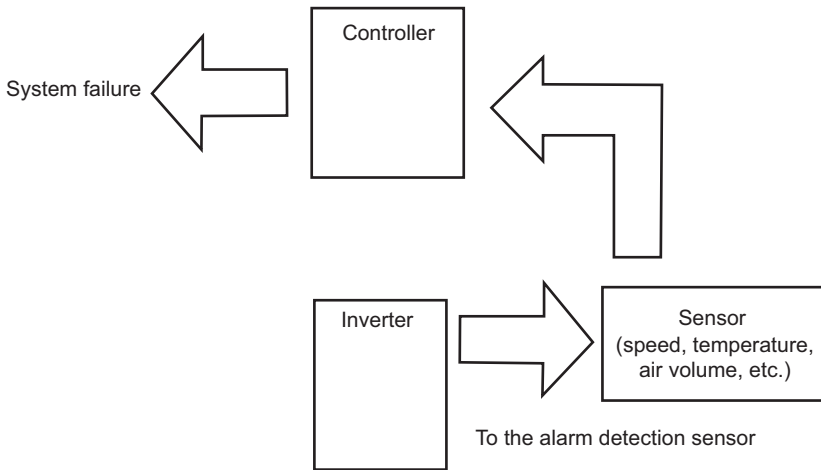

4 Specifications

This chapter explains the specifications of this product.
Always read the instructions before use.

4.1 Inverter rating

◆ Three-phase 200 V power supply

Model FR-D820-[]			0.1K-008	0.2K-014	0.4K-025	0.75K-042	1.5K-070	2.2K-100	3.7K-165	5.5K-238	7.5K-318	11K-450	15K-580	
Applicable motor capacity (kW) ^{*1}	SLD		0.2	0.4	0.75	1.1	2.2	3.7	5.5	7.5	11	15	18.5	
	ND (initial setting)		0.1	0.2	0.4	0.75	1.5	2.2	3.7	5.5	7.5	11	15	
Output Rated capacity (kVA) ^{*2}	SLD		0.5	1.0	1.6	2.3	3.8	6.3	9.1	12.1	17.1	22.1	27.4	
	ND (initial setting)		0.3	0.5	1.0	1.6	2.7	3.8	6.3	9.1	12.1	17.1	22.1	
Rated current (A) ^{*7}	SLD		1.4 (1.1)	2.5 (2.0)	4.2 (3.5)	6.0 (5.1)	10 (8.5)	16.5 (12.0)	23.8 (19.6)	31.8 (26.0)	45 (37.0)	58 (48.0)	72 (61.0)	
	ND (initial setting)		0.8	1.4	2.5	4.2	7	10	16.5	23.8	31.8	45	58	
Overload current rating ^{*3}	SLD		110% 60 s, 120% 3 s (inverse-time characteristics) at surrounding air temperature of 40°C											
	ND (initial setting)		150% 60 s, 200% 0.5 s (inverse-time characteristics) at surrounding air temperature of 50°C											
Rated voltage ^{*4}			Three-phase 200 to 240 V											
Regenerative braking	Brake transistor		Not used			Built-in								
	Maximum brake torque (ND reference) ^{*5}		150%			100%		50%		20%				
Power supply ^{*9}	Rated input AC voltage/frequency		Three-phase 200 to 240 V, 50/60 Hz											
	Permissible AC voltage fluctuation		170 to 264 V, 50/60 Hz											
	Permissible frequency fluctuation		±5%											
	Rated input current (A) ^{*8}	Without DC reactor	SLD	1.8	3.4	5.6	8.0	13.7	20.6	31.2	40.5	57.5	74.4	89.8
			ND	1.2	2.2	3.7	6.1	10.2	13.6	21.6	31.0	41.2	56.3	74.1
Power supply capacity (kVA) ^{*6}	With DC reactor	SLD	1.4	2.5	4.2	6.0	10.0	16.5	23.8	31.8	45.0	58.0	72.0	
		ND	0.8	1.4	2.5	4.2	7.0	10.0	16.5	23.8	31.8	45.0	58.0	
Protective structure	Without DC reactor	SLD	0.7	1.3	2.1	3.1	5.2	7.8	11.9	15.4	21.9	28.3	34.2	
		ND	0.4	0.8	1.4	2.3	3.9	5.2	8.2	11.8	15.7	21.5	28.2	
		SLD	0.5	1.0	1.6	2.3	3.8	6.3	9.1	12.1	17.1	22.1	27.4	
		ND	0.3	0.5	1.0	1.6	2.7	3.8	6.3	9.1	12.1	17.1	22.1	
Cooling system			Natural					Forced air						
Approx. mass (kg)			0.5	0.5	0.6	0.7	1.2	1.3	1.4	2.4	2.5	5.1	5.1	

- *1 The applicable motor capacity indicated is the maximum capacity applicable for use of the Mitsubishi Electric standard 4-pole motor.
- *2 The rated output capacity is the value with respect to 230 V output voltage.
- *3 The percentage of the overload current rating is the ratio of the overload current to the inverter's rated output current. For repeated duty, allow time for the inverter and motor to return to or below the temperatures under 100% load.
- *4 The maximum output voltage does not exceed the power supply voltage. The maximum output voltage can be changed within the setting range.
The maximum point of the voltage waveform at the output side of the inverter is approximately the power supply voltage multiplied by $\sqrt{2}$.
- *5 The amount of braking torque is the average short-term torque (which varies depending on motor loss) that is generated when a motor decelerates in the shortest time by itself from 60 Hz. It is not continuous regenerative torque. The average deceleration torque becomes lower when a motor decelerates from a frequency higher than the base frequency. The inverter is not equipped with a built-in brake resistor. Use an option brake resistor for an operation with large regenerative power (not available for the FR-D820-0.1K-008 and FR-D820-0.2K-014). The brake unit (FR-BU2) can be also used.
- *6 The power supply capacity varies with the value of the input power impedance (including those of the input reactor and cables).
- *7 The value in parentheses is the rated output current when the low acoustic noise operation is performed with the surrounding air temperature exceeding 30°C while a 3 kHz or higher value is selected in **Pr.72 PWM frequency selection**.
- *8 The rated input current is the value at a rated output voltage. The input power impedances (including those of the input reactor and cables) affect the value.
- *9 To be compliant with the standards, wire the inverter using the following earthing (grounding) and power supply methods:
TN-C (corner earthed), TN-S (corner earthed), or IT (isolated, phase earthed over impedance)

◆ Three-phase 400 V power supply

Model FR-D840-□			0.4K-012	0.75K-022	1.5K-037	2.2K-050	3.7K-081	5.5K-120	7.5K-163	11K-230	15K-295	
Applicable motor capacity (kW) ^{*1}	SLD		0.75	1.5	2.2	3.7	5.5	7.5	11	15	18.5	
	ND (initial setting)		0.4	0.75	1.5	2.2	3.7	5.5	7.5	11	15	
Output	Rated capacity (kVA) ^{*2}	SLD	1.7	2.8	3.8	6.2	9.1	12.4	17.5	22.5	29.0	
		ND (initial setting)	0.9	1.7	2.8	3.8	6.2	9.1	12.4	17.5	22.5	
	Rated current (A) ^{*7}	SLD	2.2 (1.8)	3.7 (3.0)	5 (4.2)	8.1 (6.8)	12 (10.0)	16.3 (13.8)	23 (19.5)	29.5 (25.0)	38 (32.0)	
		ND (initial setting)	1.2	2.2	3.7	5	8.1	12	16.3	23	29.5	
	Overload current rating ^{*3}	SLD	110% 60 s, 120% 3 s (inverse-time characteristics) at surrounding air temperature of 40°C									
		ND (initial setting)	150% 60 s, 200% 0.5 s (inverse-time characteristics) at surrounding air temperature of 50°C									
Rated voltage ^{*4}		Three-phase 380 to 480 V										
Regenerative braking	Brake transistor		Built-in									
	Maximum brake torque (ND reference) ^{*5}		100%	50%	20%							
Power supply ^{*9}	Rated input AC voltage/frequency		Three-phase 380 to 480 V, 50/60 Hz									
	Permissible AC voltage fluctuation		323 to 528 V, 50/60 Hz									
	Permissible frequency fluctuation		±5%									
	Rated input current (A) ^{*8}	Without DC reactor	SLD	3.1	6.0	7.8	11.9	16.1	21.3	29.1	37.9	45.5
			ND	1.8	3.2	5.7	7.6	11.4	16.3	20.9	28.7	37.6
		With DC reactor	SLD	2.2	3.7	5.0	8.1	12.0	16.3	23.0	29.5	38.0
ND			1.2	2.2	3.6	5.0	8.0	12.0	16.0	23.0	29.5	
Power supply capacity (kVA) ^{*6}	Without DC reactor	SLD	2.4	4.2	6.1	9.0	12.5	16.2	22.2	28.9	34.7	
		ND	1.4	2.7	4.4	5.8	8.6	12.4	15.9	21.9	28.6	
	With DC reactor	SLD	1.7	2.8	3.8	6.2	9.1	12.4	17.5	22.5	29.0	
		ND	0.9	1.7	2.7	3.8	6.1	9.1	12.2	17.5	22.5	
Protective structure			Open type IP20 (for IEC 60529 only)									
Cooling system			Natural			Forced air						
Approx. mass (kg)			0.8	0.8	1.1	1.3	1.4	2.3	2.4	3.8	3.9	

*1 The applicable motor capacity indicated is the maximum capacity applicable for use of the Mitsubishi Electric standard 4-pole motor.

*2 The rated output capacity is the value with respect to 440 V output voltage.

*3 The percentage of the overload current rating is the ratio of the overload current to the inverter's rated output current. For repeated duty, allow time for the inverter and motor to return to or below the temperatures under 100% load.

*4 The maximum output voltage does not exceed the power supply voltage. The maximum output voltage can be changed within the setting range.

The maximum point of the voltage waveform at the output side of the inverter is approximately the power supply voltage multiplied by $\sqrt{2}$.

*5 The amount of braking torque is the average short-term torque (which varies depending on motor loss) that is generated when a motor decelerates in the shortest time by itself from 60 Hz. It is not continuous regenerative torque. The average deceleration torque becomes lower when a motor decelerates from a frequency higher than the base frequency. The inverter is not equipped with a built-in brake resistor. Use an option brake resistor for an operation with large regenerative power. The brake unit (FR-BU2) can be also used.

*6 The power supply capacity varies with the value of the input power impedance (including those of the input reactor and cables).

*7 The value in parentheses is the rated output current when the low acoustic noise operation is performed with the surrounding air temperature exceeding 30°C while a 3 kHz or higher value is selected in **Pr.72 PWM frequency selection**.

*8 The rated input current is the value at a rated output voltage. The input power impedances (including those of the input reactor and cables) affect the value.

*9 To be compliant with the standards, wire the inverter using the following earthing (grounding) and power supply methods: TN-C (neutral earthed), TN-S (neutral earthed), or IT (isolated, neutral over impedance)

◆ Single-phase 200 V power supply

Model FR-D820S-□			0.1K-008	0.2K-014	0.4K-025	0.75K-042	1.5K-070	2.2K-100	
Applicable motor capacity (kW) ^{*1}		ND	0.1	0.2	0.4	0.75	1.5	2.2	
Output	Rated capacity (kVA) ^{*2}	ND	0.3	0.5	1.0	1.6	2.7	3.8	
	Rated current (A)	ND	0.8	1.4	2.5	4.2	7	10	
	Overload current rating ^{*3}	ND	150% 60 s, 200% 0.5 s (inverse-time characteristics) at surrounding air temperature of 50°C						
	Rated voltage ^{*4}	Three-phase 200 to 240 V							
	Regenerative braking	Brake transistor	Not used			Built-in			
Maximum brake torque (ND reference) ^{*5}		150%			100%		50%	20%	
Power supply ^{*8}	Rated input AC voltage/frequency		Single-phase 200 to 240 V, 50/60 Hz						
	Permissible AC voltage fluctuation		170 to 264 V, 50/60 Hz						
	Permissible frequency fluctuation		±5%						
	Rated input current (A) ^{*7}	Without DC reactor	ND	2.3	3.9	6.6	10.9	17.4	24.2
		With DC reactor		1.1	2.1	3.7	6.7	12.6	17.8
	Power supply capacity (kVA) ^{*6}	Without DC reactor	ND	0.5	0.9	1.4	2.4	3.8	5.3
With DC reactor			0.2	0.5	0.8	1.5	2.8	3.9	
Protective structure			Open type IP20 (for IEC 60529 only)						
Cooling system			Natural					Forced air	
Approx. mass (kg)			0.5	0.5	0.7	0.8	1.3	1.4	

*1 The applicable motor capacity indicated is the maximum capacity applicable for use of the Mitsubishi Electric standard 4-pole motor.

*2 The rated output capacity is the value with respect to 230 V output voltage.

*3 The percentage of the overload current rating is the ratio of the overload current to the inverter's rated output current. For repeated duty, allow time for the inverter and motor to return to or below the temperatures under 100% load. For single-phase power input model, the bus voltage decreases to power failure detection level and the load of 100% or higher may not be available if the automatic restart after instantaneous power failure function (**Pr.57**) or the power failure stop function (**Pr.261**) is set and power supply voltage is low while the load increases.

*4 The maximum output voltage does not exceed the power supply voltage. The maximum output voltage can be changed within the setting range.

The maximum point of the voltage waveform at the output side of the inverter is approximately the power supply voltage multiplied by $\sqrt{2}$.

*5 The amount of braking torque is the average short-term torque (which varies depending on motor loss) that is generated when a motor decelerates in the shortest time by itself from 60 Hz. It is not continuous regenerative torque. The average deceleration torque becomes lower when a motor decelerates from a frequency higher than the base frequency. The inverter is not equipped with a built-in brake resistor. Use an option brake resistor for an operation with large regenerative power (not available for the FR-D820S-0.1K-008 and FR-D820S-0.2K-014). The brake unit (FR-BU2) can be also used.

*6 The power supply capacity varies with the value of the input power impedance (including those of the input reactor and cables).

*7 The rated input current is the value at a rated output voltage. The input power impedances (including those of the input reactor and cables) affect the value.

*8 To be compliant with the standards, wire the inverter using the following earthing (grounding) and power supply methods: TN-C, TN-S, or IT (Isolated, neutral or phase earthed over impedance)

◆ Single-phase 100 V power supply

Model FR-D810W-[]		0.1K-008	0.2K-014	0.4K-025	0.75K-042	
Applicable motor capacity (kW) ^{*1}	ND	0.1	0.2	0.4	0.75	
Output	Rated capacity (kVA) ^{*2}	0.3	0.5	1.0	1.6	
	Rated current (A)	0.8	1.4	2.5	4.2	
	Overload current rating ^{*3}	150% 60 s, 200% 0.5 s (inverse-time characteristics) at surrounding air temperature of 50°C				
	Rated voltage ^{*7,8}	Three-phase 200 to 240 V				
	Regenerative braking	Brake transistor	Not used		Built-in	
Maximum brake torque (ND reference) ^{*4}		150%		100%		
Power supply ^{*9}	Rated input AC voltage/frequency		Single-phase 100 to 120 V, 50/60 Hz			
	Permissible AC voltage fluctuation		90 to 132 V, 50/60 Hz			
	Permissible frequency fluctuation		±5%			
	Rated input current (A) ^{*6}	ND	3.8	6.2	10.5	18.8
	Power supply capacity (kVA) ^{*5}	ND	0.4	0.6	1.1	1.8
Protective structure		Open type IP20 (for IEC 60529 only)				
Cooling system		Natural				
Approx. mass (kg)		0.5	0.6	0.7	1.3	

*1 The applicable motor capacity indicated is the maximum capacity applicable for use of the Mitsubishi Electric standard 4-pole motor.

*2 The rated output capacity is the value with respect to 230 V output voltage.

*3 The percentage of the overload current rating is the ratio of the overload current to the inverter's rated output current. For repeated duty, allow time for the inverter and motor to return to or below the temperatures under 100% load. For single-phase power input model, the bus voltage decreases to power failure detection level and the load of 100% or higher may not be available if the automatic restart after instantaneous power failure function (**Pr.57**) or the power failure stop function (**Pr.261**) is set and power supply voltage is low while the load increases.

*4 The amount of braking torque is the average short-term torque (which varies depending on motor loss) that is generated when a motor decelerates in the shortest time by itself from 60 Hz. It is not continuous regenerative torque. The average deceleration torque becomes lower when a motor decelerates from a frequency higher than the base frequency. The inverter is not equipped with a built-in brake resistor. Use an option brake resistor for an operation with large regenerative power (not available for the FR-D810W-0.1K-008 and FR-D810W-0.2K-014). The brake unit (FR-BU2) can be also used.

*5 The power supply capacity varies with the value of the input power impedance (including those of the input reactor and cables).

*6 The rated input current is the value at a rated output voltage. The input power impedances (including those of the input reactor and cables) affect the value.

*7 For the single-phase 100 V power input models, the maximum output voltage is twice the amount of the power supply voltage.

*8 For the single-phase 100 V power input models, output voltage decreases by applying motor load, and output current increases compared to the three-phase power input models. The load must be reduced so that output current does not exceed the rated motor current.

*9 To be compliant with the standards, wire the inverter using the following earthing (grounding) and power supply methods: TN-C, TN-S, or IT (Isolated, neutral or phase earthed over impedance)

4.2 Motor rating

4.2.1 PM motor EM-A

◆ Motor specifications

EM-AMF 0.1kW 3000r/min 200V

A B C D E

- A: Electromagnetic brake

Symbol	Electromagnetic brake
None	Without
B	With

- B: Shaft end

Symbol	Shaft end
None	Standard
K	Key shaft

- C: Protective structure

Symbol	Protective structure
None	IP44
W	IP65

- D: Output power

Symbol	Description
0.1kW to 7.5kW	Rated capacity (kW)

- E: Voltage class

Symbol	Description
200V	200 V class
400V	400 V class

◆ Specifications of the dedicated PM motor (EM-A motor) (200 V class)

■ Motor specifications (standard)

Motor model: EM-AMF□	0.1kW	0.2kW	0.4kW	0.75kW	1.5kW	2.2kW	3.7kW	5.5kW	7.5kW
Applicable inverter model FR-D820-□ ^{*7}	0.1K-008	0.2K-014	0.4K-025	0.75K-042	1.5K-070	2.2K-100	3.7K-165	5.5K-238	7.5K-318
Rated speed (r/min)	3000								
Maximum speed (r/min)	4000								
Number of poles	4				6				
Rated current (A)	0.55	1.1	1.8	3.3	6.1	9.3	16.5	22	31
Rated torque (N·m) ^{*1*8}	0.32	0.64	1.27	2.39	4.77	7.00	11.8	17.5	23.9
Maximum torque (%)	200%								
Insulation class	130(B)						155(F)		
Recommended load inertia moment ratio	10 times max.								
Structure	Totally enclosed self-cooling								
Protective structure	IP44 ^{*2} , IP65 ^{*2*3}								
Environment ^{*5}	Surrounding air temperature and humidity	0°C to +40°C (non-freezing), 90% RH or less (non-condensing)							
	Altitude	Maximum 1000 m							
	Vibration resistance ^{*4}	4.9 m/s ² or less (momentarily tolerable up to 9.8 m/s ²)							
Permissible load on the shaft ^{*6}	L (mm)	17	22	30	41.5				
	Radial (N)	392	490	686	1470				
	Thrust (N)	196	294	490	980				
Mass (kg)	Without brake	2.9	4.9	6.4	9.5	11.7	22	28	34
	With brake	3.9	6.7	8.2	12.2	14.4	28	34	40

*1 The above characteristics apply when the rated AC voltage is input from the inverter (refer to [page 111](#)). The rated output power or speed is not guaranteed at low supply voltages.

*2 Except for the shaft hole.

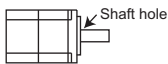

*3 Applicable for EM-AMF□□W motors.

*4 For the vibration direction, X indicates the direction of the motor output axis and Y indicates the direction perpendicular to the motor output axis. The numbers are values at points where the maximum values are indicated (normally the bracket at the non-load side). Bearings are subjected to fretting while the motor is stopped. Suppress the vibration to about the half of the permissible value.

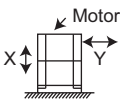

*5 The standard motor may not be used under the condition where it is constantly exposed to oil mist, oil, or water. For details, contact your sales representative.

*6 For the permissible load on the shaft, refer to the following figure. On the shaft, do not apply a load exceeding the value in the table. Each value in the table shows the permissible value for the single load application.

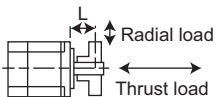

L: Distance from the flange mounting surface to the center of the load

*7 By setting **Pr.80**, a motor with one rank lower capacity than the inverter capacity can be used. To use a motor capacity that is one rank lower than the inverter capacity, set **Pr.80 Motor capacity** before performing PM parameter initialization. (Refer to the Instruction Manual (Function).)

*8 To drive a machine that produces unbalanced torque, such as a lift axis, the unbalanced torque is recommended to be equal to or less than the 90% of the rated torque (or to be equal to or less than the rated torque for 0.75 kW).

◆ Specifications of the dedicated PM motor (EM-A motor) (400 V class)

■ Motor specifications (standard)

Motor model: EM-AMF□		0.4kW	0.75kW	1.5kW	2.2kW	3.7kW	5.5kW	7.5kW
Applicable inverter model FR-D840-□ ^{*7}		0.4K-012	0.75K-022	1.5K-037	2.2K-050	3.7K-081	5.5K-120	7.5K-163
Rated speed (r/min)		3000						
Maximum speed (r/min)		4000						
Number of poles		4			6			
Rated current (A)		0.9	1.7	3.1	4.7	8.3	11	15.5
Rated torque (N·m) ^{*1*8}		1.27	2.39	4.77	7.00	11.8	17.5	23.9
Maximum torque (%)		200%						
Insulation class		130(B)				155(F)		
Recommended load inertia moment ratio		10 times max.						
Structure		Totally enclosed self-cooling						
Protective structure		IP44 ^{*2} , IP65 ^{*2*3}						
Environment ^{*5}	Surrounding air temperature and humidity	0°C to +40°C (non-freezing), 90% RH or less (non-condensing)						
	Altitude	Maximum 1000 m						
	Vibration resistance ^{*4}	4.9 m/s ² or less (momentarily tolerable up to 9.8 m/s ²)						
Permissible load on the shaft ^{*6}	L (mm)	22			30		41.5	
	Radial (N)	490			686		1470	
	Thrust (N)	294			490		980	
Mass (kg)	Without brake	4.9	6.4	9.5	11.7	22	28	34
	With brake	6.7	8.2	12.2	14.4	28	34	40

*1 The above characteristics apply when the rated AC voltage is input from the inverter (refer to page 111). The rated output power or speed is not guaranteed at low supply voltages.

*2 Except for the shaft hole.

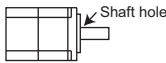

*3 Applicable for EM-AMF□□□W motors.

*4 For the vibration direction, X indicates the direction of the motor output axis and Y indicates the direction perpendicular to the motor output axis. The numbers are values at points where the maximum values are indicated (normally the bracket at the non-load side). Bearings are subjected to fretting while the motor is stopped. Suppress the vibration to about the half of the permissible value.

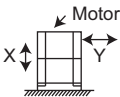

*5 The standard motor may not be used under the condition where it is constantly exposed to oil mist, oil, or water. For details, contact your sales representative.

*6 For the permissible load on the shaft, refer to the following figure. On the shaft, do not apply a load exceeding the value in the table. Each value in the table shows the permissible value for the single load application.

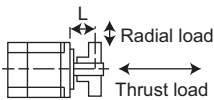

L: Distance from the flange mounting surface to the center of the load

*7 By setting Pr.80, a motor with one rank lower capacity than the inverter capacity can be used. To use a motor capacity that is one rank lower than the inverter capacity, set Pr.80 Motor capacity before performing PM parameter initialization. (Refer to the Instruction Manual (Function).)

*8 To drive a machine that produces unbalanced torque, such as a lift axis, the unbalanced torque is recommended to be equal to or less than the 90% of the rated torque.

◆ Motor torque

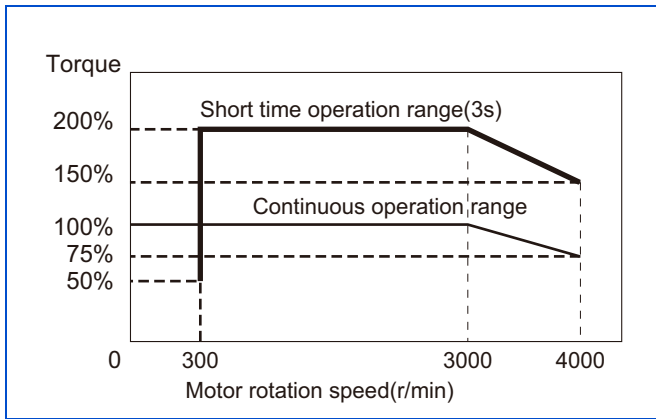

- When the input voltage is low, the torque may be reduced.
- In the low-speed range, torque ripples or uneven rotation occur. Adjust the setting of **Pr.820 Speed control P gain 1** as required.

4.3 Common specifications

Control	Control method		Soft-PWM control / High carrier frequency PWM control
		Induction motor	Selectable among V/F control and Advanced magnetic flux vector control
		PM motor	PM sensorless vector control
	Output frequency range	Induction motor	0.2 to 590 Hz (The upper-limit frequency is 400 Hz under Advanced magnetic flux vector control.)
		PM motor	0.2 to 400 Hz (not operable at a frequency higher than the maximum motor frequency)
	Frequency setting and resolution	Analog input	0.015 Hz / 0 to 60 Hz at 0 to 10 V / 12 bits (terminals 2 and 4) 0.03 Hz / 60 Hz at 0 to 5 V / 11 bits or 0 to 20 mA / 11 bits (terminals 2 and 4)
		Digital input	0.01 Hz
	Frequency accuracy	Analog input	Within $\pm 0.2\%$ of the maximum output frequency ($25^{\circ}\text{C} \pm 10^{\circ}\text{C}$)
		Digital input	0.01% or less of the set output frequency
	Voltage/frequency characteristics		Base frequency can be set from 0 to 590 Hz. Constant-torque/variable-torque pattern can be selected (with induction motor only).
	Starting torque	Induction motor	Advanced magnetic flux vector control: 200% at 0.5 Hz (3.7K or lower), 150% at 0.5 Hz (5.5K or higher)
		PM motor	50%
	Torque boost		Manual torque boost (induction motor only)
	Acceleration/deceleration time setting		0 to 3600 s (acceleration and deceleration can be set individually), linear or S-pattern acceleration/ deceleration modes are available.
DC injection brake	Induction motor	Operation frequency (0 to 120 Hz), operation time (0 to 10 s), operation voltage (0% to 30%) variable (The current is limited at the inverter rated current.)	
	PM motor	Operation time (0 to 10 s) variable, operating voltage (operating current) fixed	
Stall prevention operation level		Operation current: 0% to 200% variable, with selectable availability of the function	
Torque limit level		Torque limit value: 0% to 400% variable (under PM sensorless vector control only)	
Operation	Frequency setting signal	Analog input	Terminals 2 and 4: 0 to 10 V / 0 to 5 V / 4 to 20 mA (0 to 20 mA)
		Digital input	Input using the operation panel or parameter unit
		Pulse train input	100k pulses/s (inverter)
	Start signal		Forward and reverse rotation or start signal automatic self-holding input (3-wire input) can be selected.
	Input signal		5 Low-speed operation command, middle-speed operation command, high-speed operation command, forward rotation command, reverse rotation command The input signal can be changed using Pr.178 to Pr.182 (Input terminal function selection) .
	Operational function		Maximum and minimum frequency settings, multi-speed operation, acceleration/deceleration pattern, thermal protection, DC injection brake, starting frequency, JOG operation, output stop (MRS), stall prevention, regeneration avoidance, increased magnetic excitation deceleration, frequency jump, rotation display, automatic restart after instantaneous power failure, remote setting, retry function, carrier frequency selection, fast-response current limit, forward/reverse rotation prevention, operation mode selection, slip compensation, speed smoothing control, traverse, auto tuning, applied motor selection, RS-485 communication, PID control, easy dancer control, cooling fan operation selection, stop selection (deceleration stop/coasting), power failure time deceleration-to-stop function, life diagnosis, maintenance timer, current average monitor, multiple rating, speed control, torque limit, test operation, safety stop function, emergency drive, Optimum excitation control
	Output signal	Open collector output	2
Relay output		1	The output signal can be changed using Pr.190 to Pr.192 (Output terminal function selection) .
Analog output		Terminal AM: 0 to +10 V / 12 bits	

Protective /warning function	Protective functions	Overcurrent trip during acceleration, overcurrent trip during constant speed, overcurrent trip during deceleration/stop, regenerative overvoltage trip during acceleration, regenerative overvoltage trip during constant speed, regenerative overvoltage trip during deceleration or stop, inverter overload trip (electronic thermal relay function), motor overload trip (electronic thermal relay function), heat sink overheat, undervoltage, input phase loss ^{*1} , stall prevention stop, loss of synchronism detection ^{*2} , upper limit fault detection, lower limit fault detection, brake transistor fault, output side earth (ground) fault overcurrent, output short circuit, inrush resistance overheat, output phase loss, external thermal relay operation, PTC thermistor operation ^{*2} , Internal storage device fault, parameter storage device fault, disconnected PU, retry count excess, CPU fault, abnormal output current detection, USB communication fault, analog input fault, safety circuit fault, speed deviation excess detection ^{*2} , PID signal fault, internal circuit fault
	Warning functions	Fan alarm, stall prevention (overcurrent), stall prevention (overvoltage), regenerative brake pre-alarm ^{*2} , electronic thermal relay function pre-alarm, PU stop, maintenance timer alarm, parameter write error, operation panel lock ^{*2} , Password locked ^{*2} , safety stop, load fault warning ^{*2} , emergency drive in operation ^{*2} , Continuous operation during communication fault ^{*2} , incorrect parameter setting
Environment	Surrounding air temperature	-20°C to +60°C (non-freezing) SLD rating: The rated current must be reduced at a temperature above 40°C. ND rating: The rated current must be reduced at a temperature above 50°C. (For information on output current reduction, refer to page 39 .)
	Surrounding air humidity	95% RH or less (non-condensing) (With circuit board coating (conforming to IEC 60721-3-3:1994 3C2/3S2)) 90% RH or less (non-condensing) (Without circuit board coating)
	Storage temperature ^{*3}	-40°C to +70°C
	Ambience	Indoors (free from corrosive gas, flammable gas, oil mist, dust and dirt)
	Altitude/vibration	Maximum 3000 m ^{*4} , 5.9 m/s ² or less at 10 to 55 Hz in X, Y, and Z directions

*1 Available for the three-phase power input model.

*2 Not activated in the inverter in the initial state.

*3 Applicable to conditions for a short time, for example, in transit.

*4 For the installation at an altitude above 1000 m, consider a 3% reduction in the rated current per 500 m increase in altitude.

4.4 Outline dimension drawings

4.4.1 Inverter outline dimension drawings

FR-D820-0.1K-008, FR-D820-0.2K-014, FR-D820-0.4K-025, FR-D820-0.75K-042
 FR-D840-0.4K-012, FR-D840-0.75K-022, FR-D840-1.5K-037
 FR-D820S-0.1K-008, FR-D820S-0.2K-014, FR-D820S-0.4K-025, FR-D820S-0.75K-042
 FR-D810W-0.1K-008, FR-D810W-0.2K-014, FR-D810W-0.4K-025

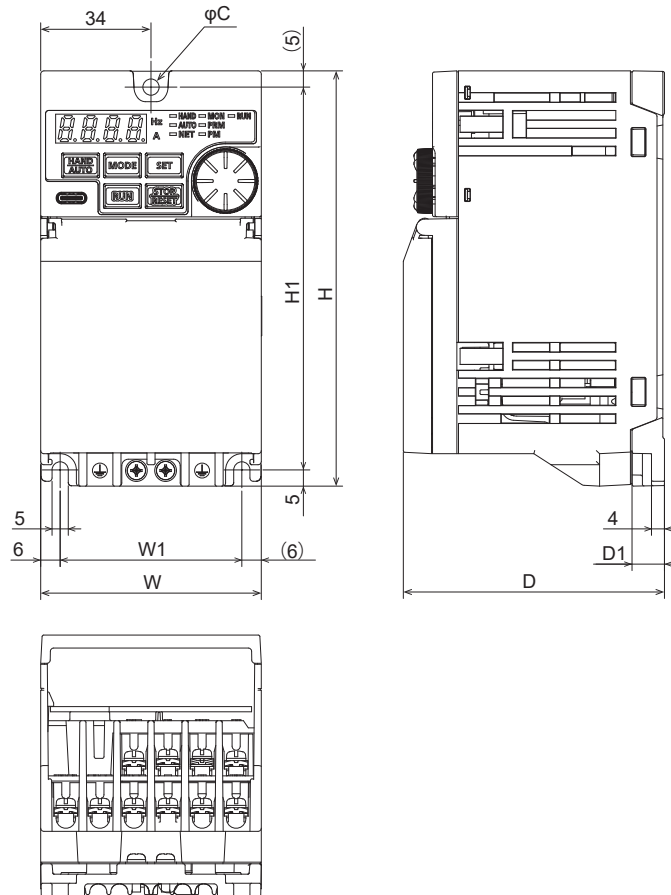

Inverter model	W	W1	H	H1	D	D1	C
FR-D820-0.1K-008 FR-D820-0.2K-014	68	56	128	118	80.5	10	5
FR-D820-0.4K-025 FR-D820-0.75K-042					102.5	32	
FR-D840-0.4K-012 FR-D840-0.75K-022					129.5	42	
FR-D840-1.5K-037					167.5	62	
FR-D820S-0.1K-008 FR-D820S-0.2K-014					80.5	10	
FR-D820S-0.4K-025 FR-D820S-0.75K-042					132.5	32	
FR-D820S-0.75K-042					142.5	42	
FR-D810W-0.1K-008 FR-D810W-0.2K-014					80.5	10	
FR-D810W-0.2K-014 FR-D810W-0.4K-025					110.5	10	
FR-D810W-0.4K-025					132.5	32	

(Unit: mm)

FR-D820-1.5K-070, FR-D820-2.2K-100, FR-D820-3.7K-165
 FR-D840-2.2K-050, FR-D840-3.7K-081
 FR-D820S-1.5K-070, FR-D820S-2.2K-100
 FR-D810W-0.75K-042

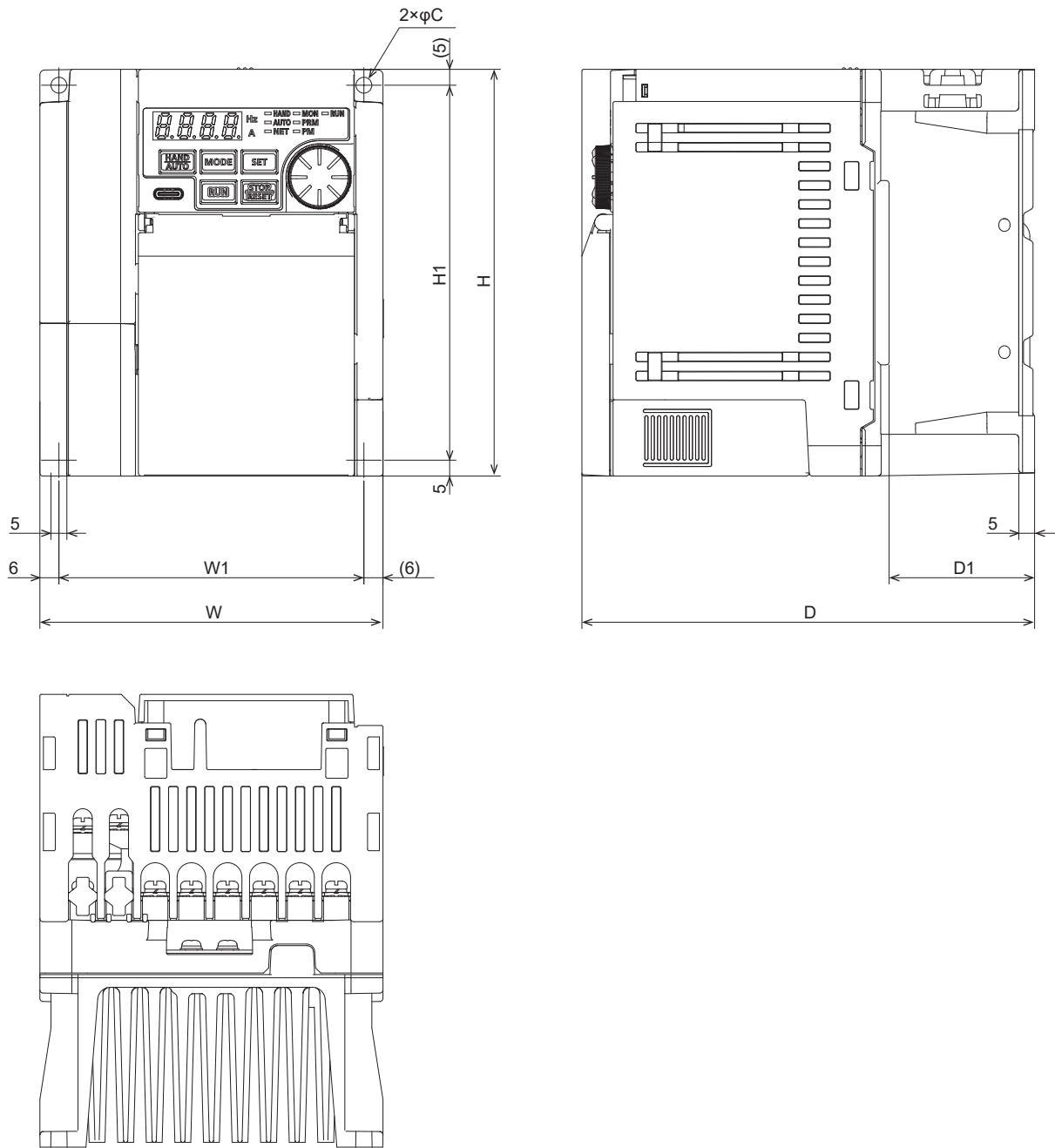

Inverter model	W	W1	H	H1	D	D1	C
FR-D820-1.5K-070 FR-D820-2.2K-100	108	96	128	118	132.5	36	5
FR-D820-3.7K-165					142.5	46	
FR-D840-2.2K-050 FR-D840-3.7K-081	108	96	128	118	155.5	36	5
FR-D820S-1.5K-070 FR-D820S-2.2K-100					145	36	
FR-D810W-0.75K-042					145	36	

(Unit: mm)

FR-D820-5.5K-238, FR-D820-7.5K-318
 FR-D840-5.5K-120, FR-D840-7.5K-163

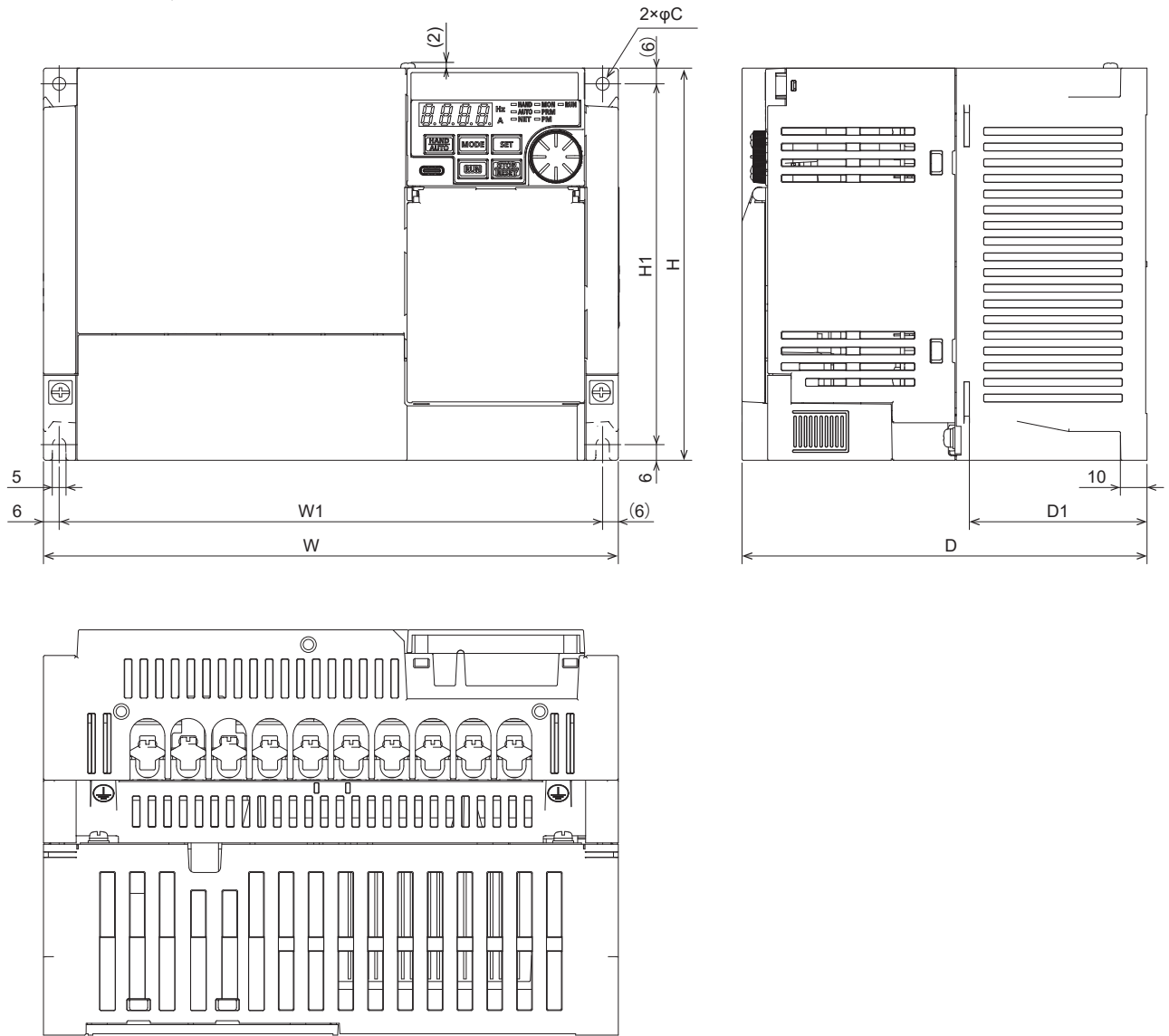

4

Inverter model	W	W1	H	H1	D	D1	C
FR-D820-5.5K-238 FR-D820-7.5K-318	220	208	150	138	155	68	5
FR-D840-5.5K-120 FR-D840-7.5K-163							

(Unit: mm)

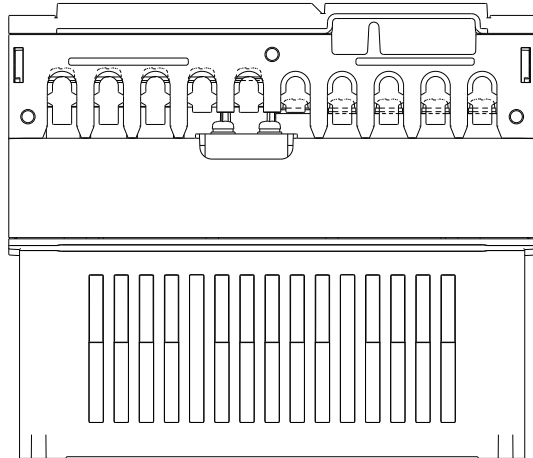
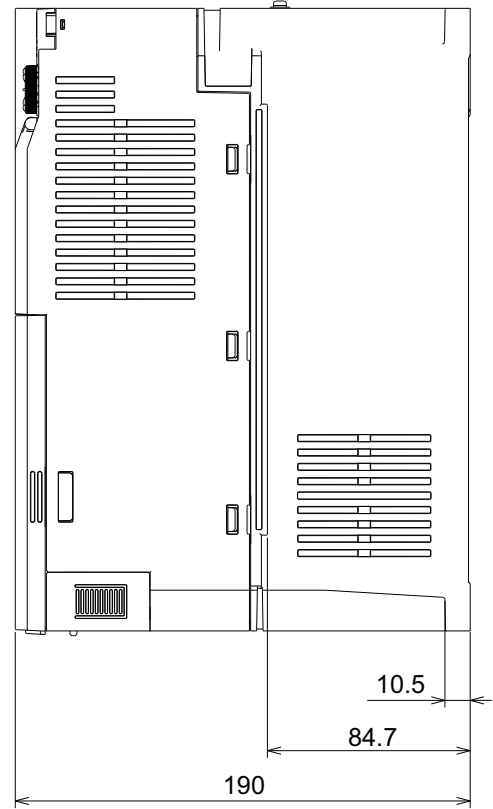
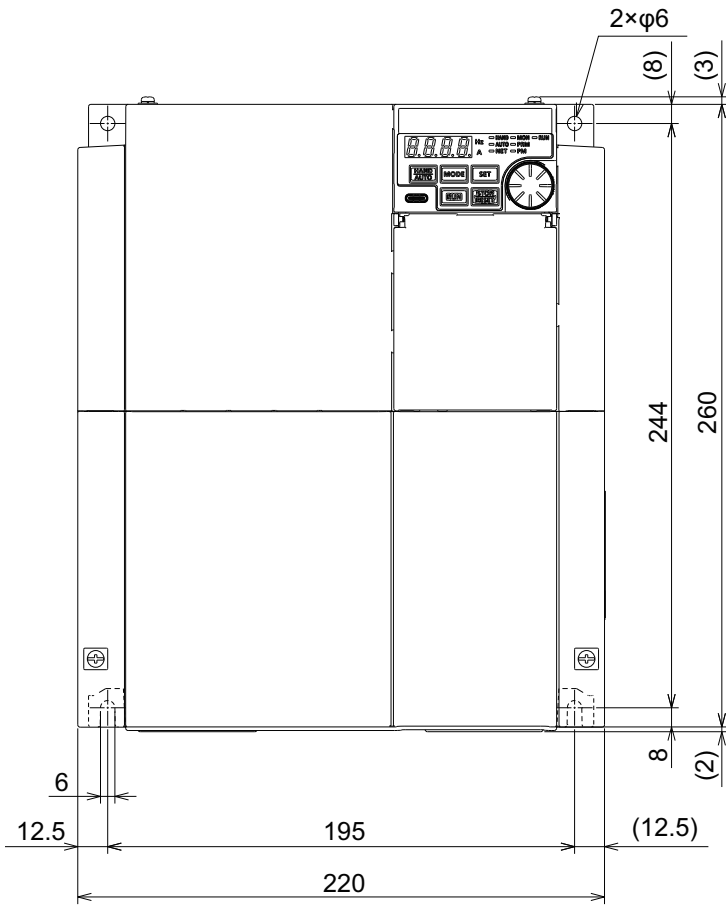

(Unit: mm)

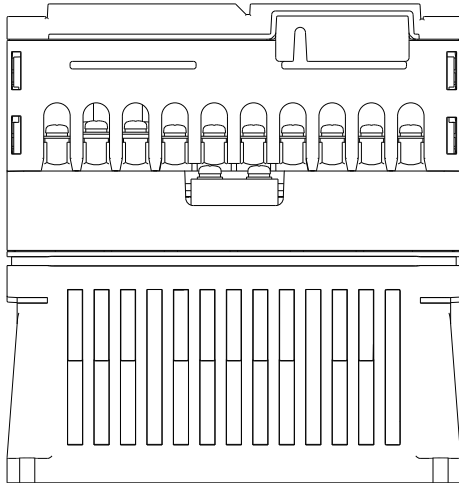
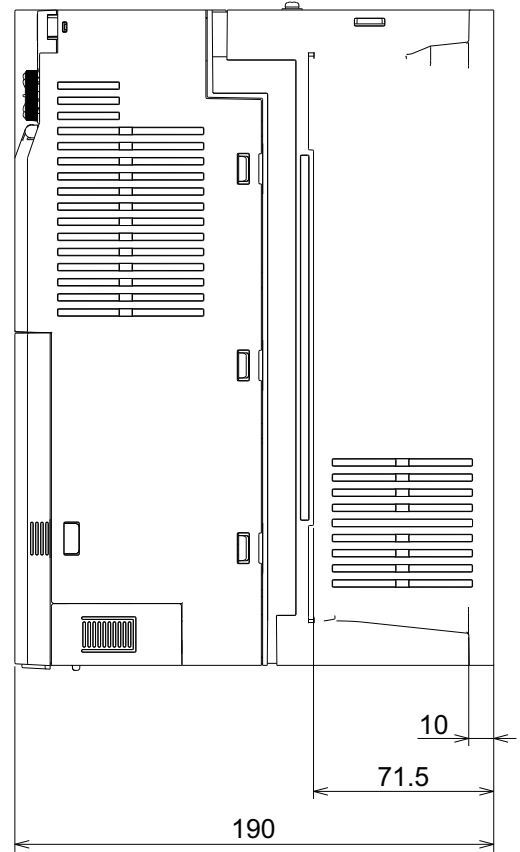
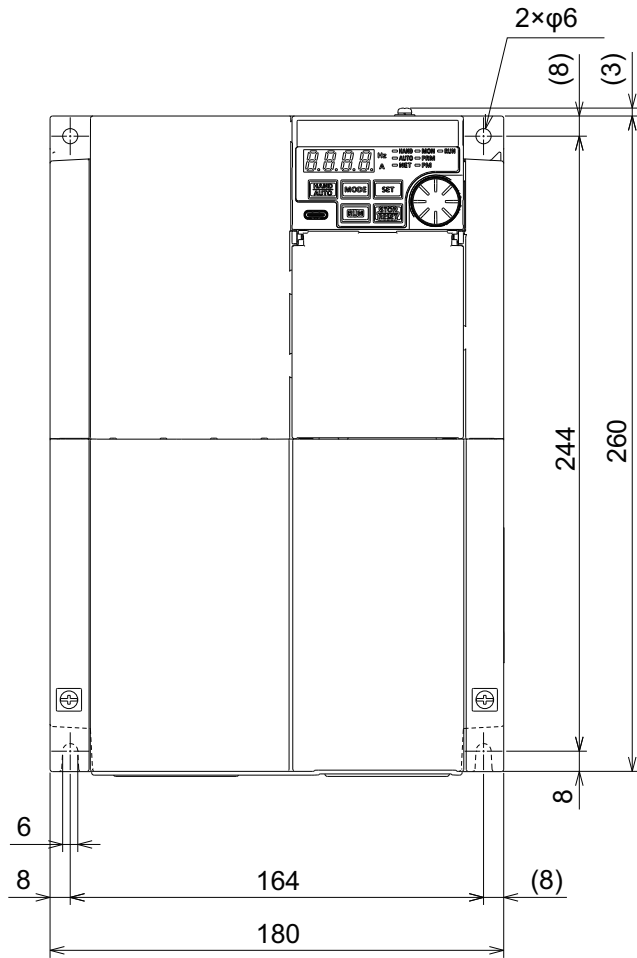

(Unit: mm)

4.4.2 Dedicated motor outline dimension drawings

◆ Dedicated PM motor (EM-A) outline dimension drawings

■ EM-AMF

0.1kW, 0.2kW

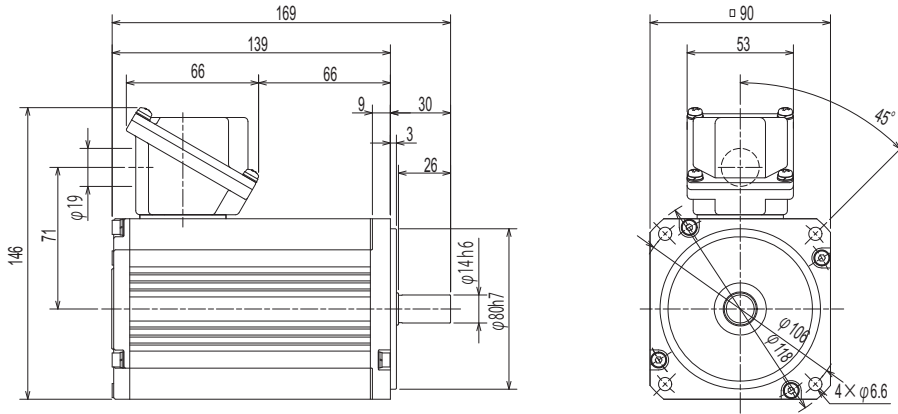

0.4 kW

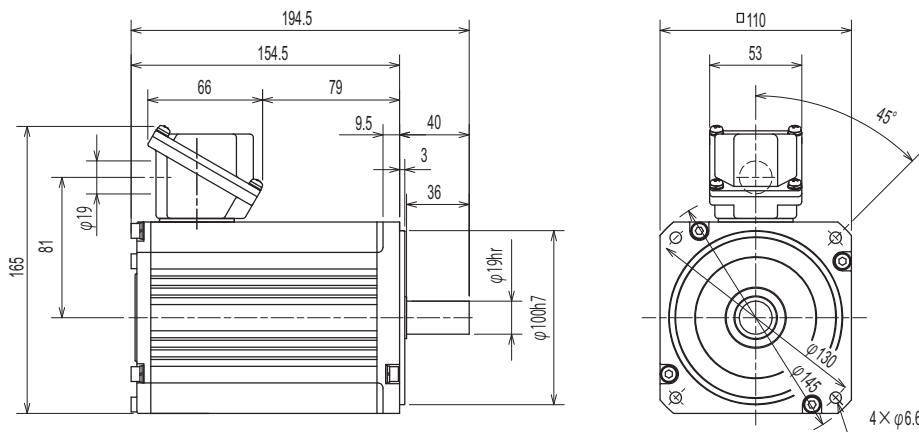

0.75kW

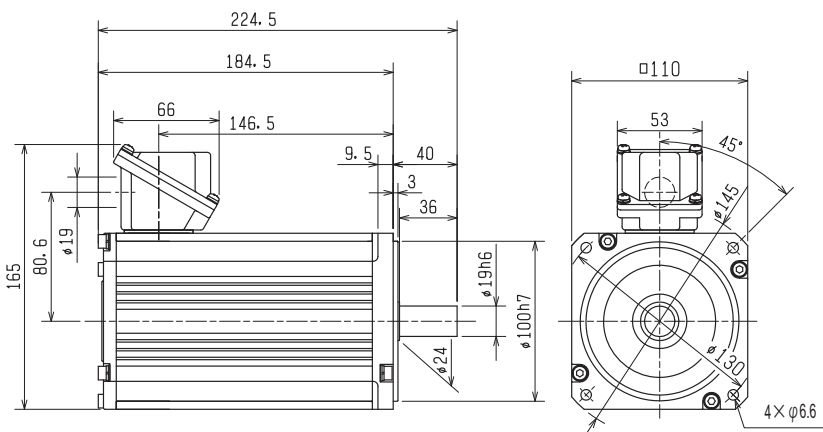

(Unit: mm)

1.5 kW

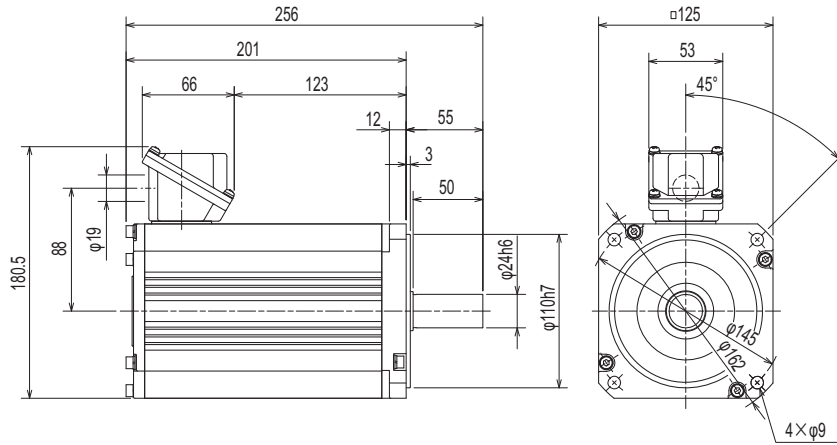

2.2kW

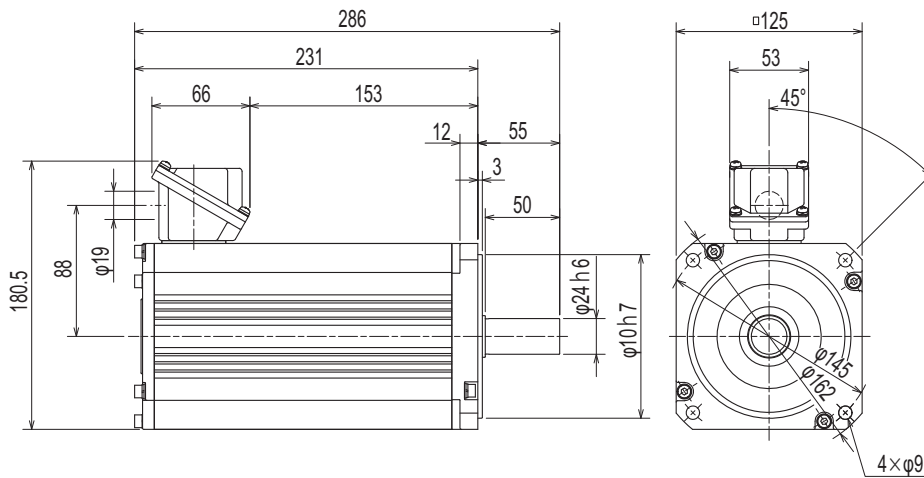

3.7kW

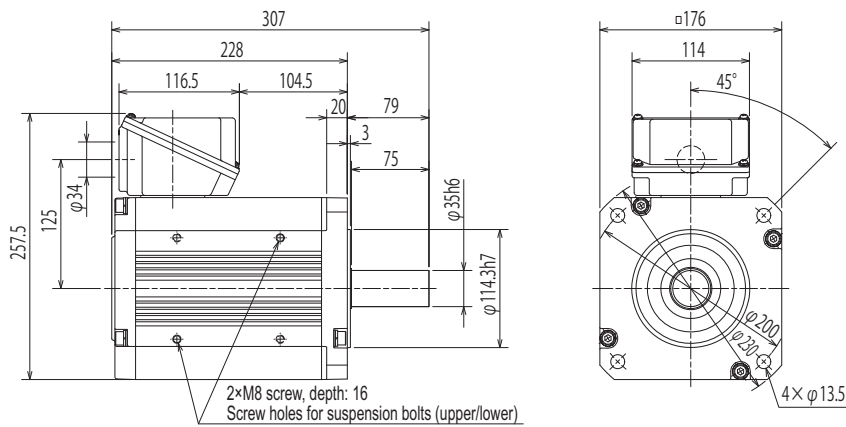

(Unit: mm)

5.5 kW

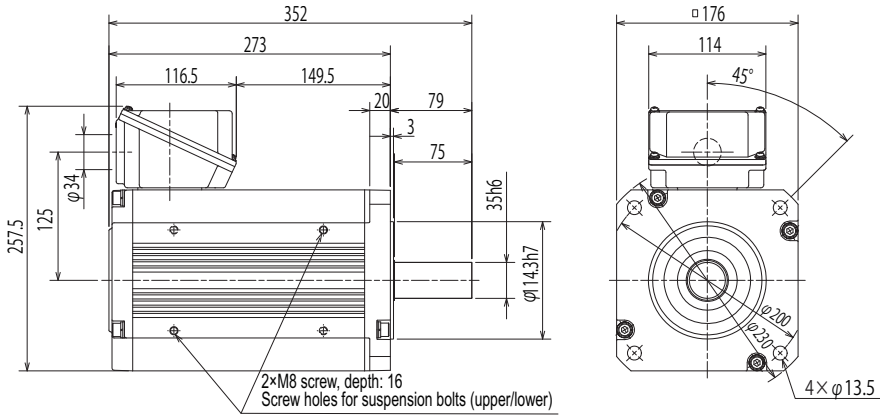

7.5kW

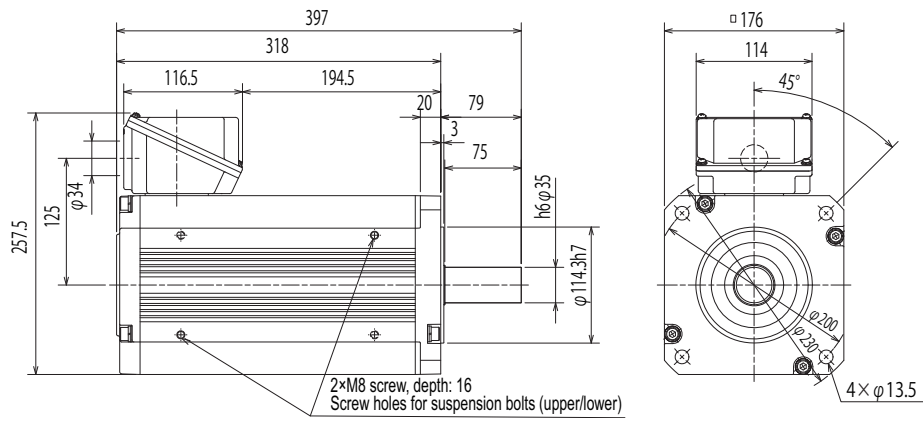

(Unit: mm)

■ EM-AMFB

0.1kW, 0.2kW

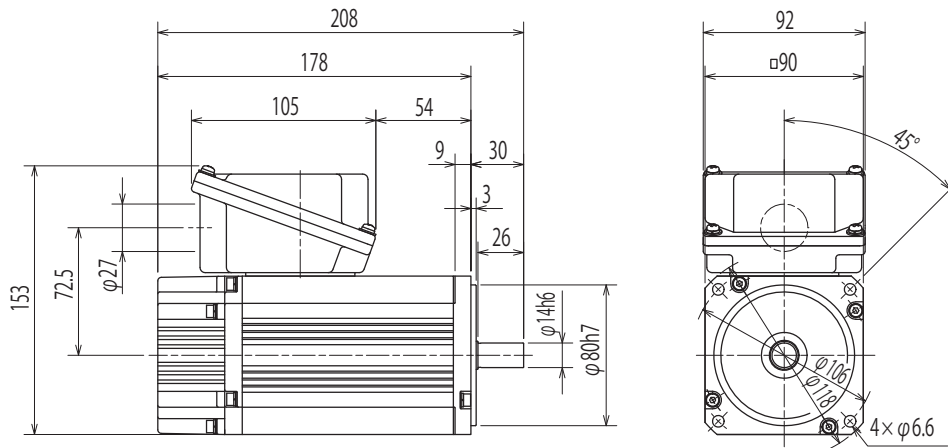

0.4 kW

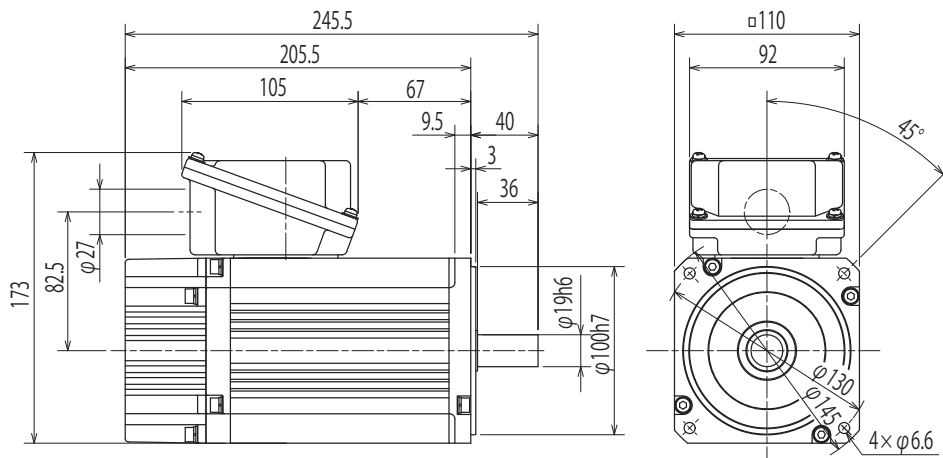

0.75kW

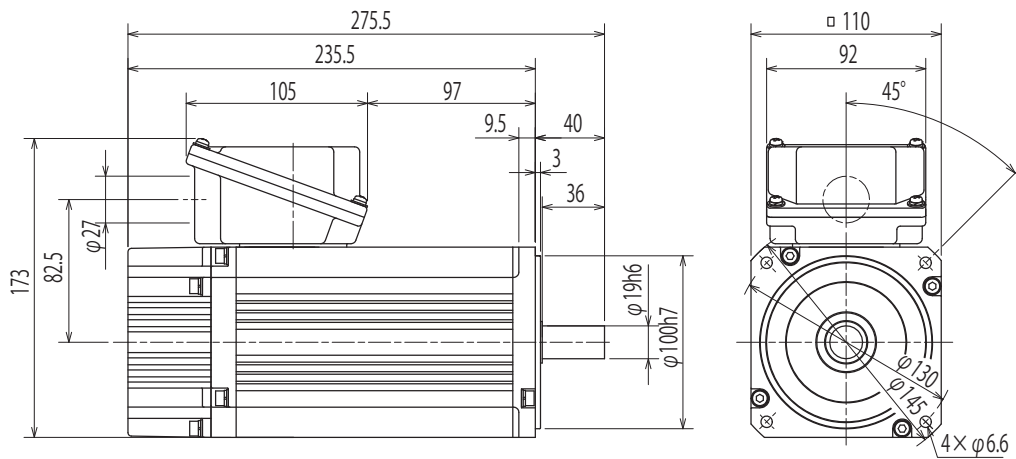

(Unit: mm)

1.5 kW

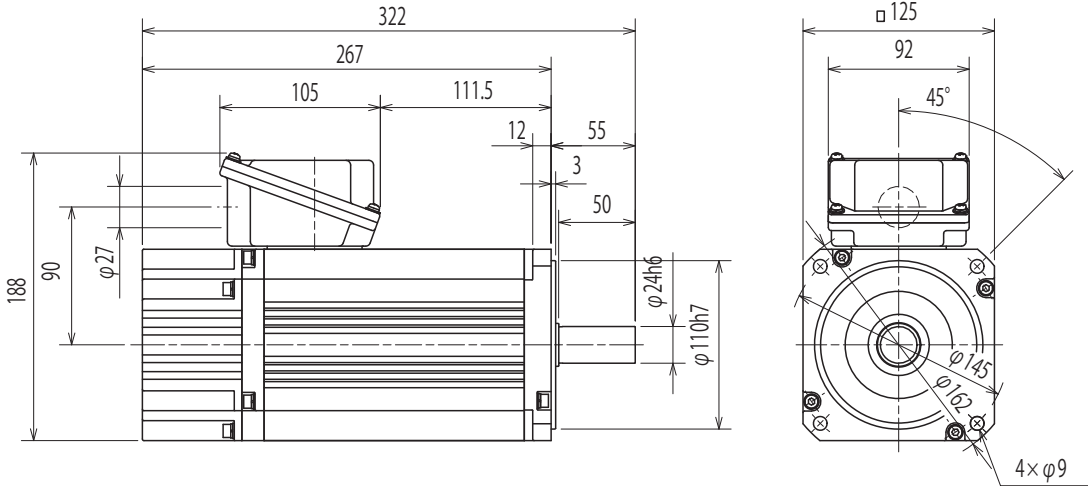

2.2kW

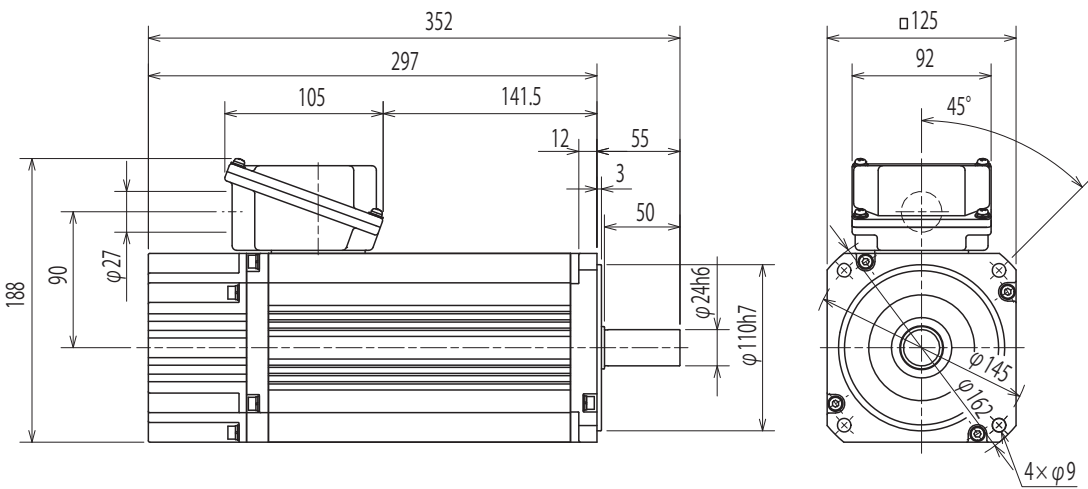

3.7kW

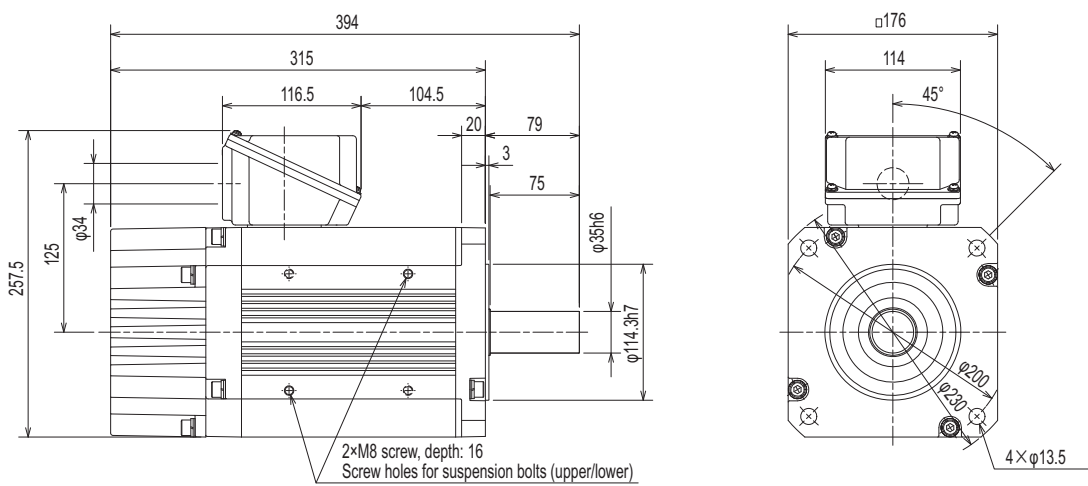

(Unit: mm)

5.5 kW

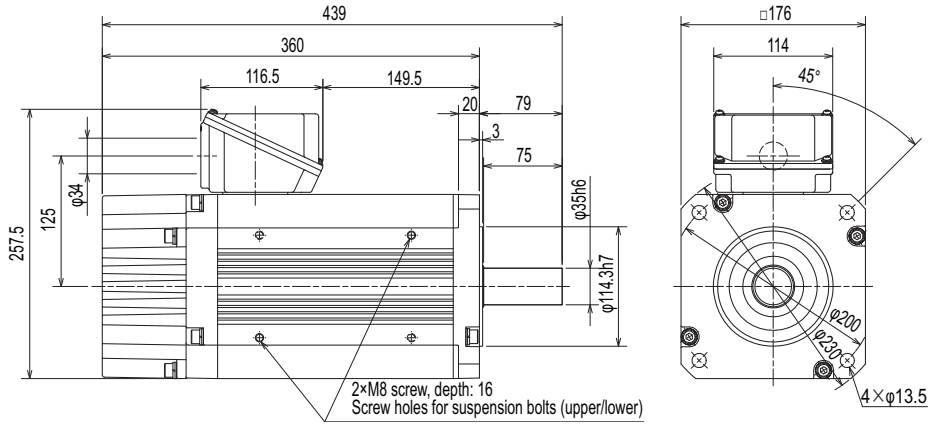

7.5 kW

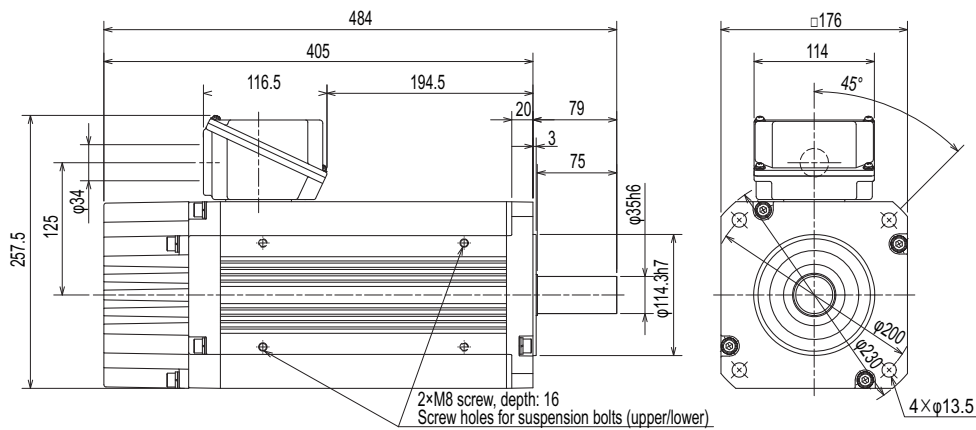

(Unit: mm)

5 Appendix

5.1 Instructions for EAC



The product certified in compliance with the Eurasian Conformity has the EAC marking.

Note: EAC marking

In 2010, three countries (Russia, Belarus, and Kazakhstan) established a Customs Union for the purposes of revitalizing the economy by forming a large economic bloc by abolishing or reducing tariffs and unifying regulatory procedures for the handling of articles.

Products to be distributed over these three countries of the Customs Union must comply with the Customs Union Technical Regulations (CU-TR), and the EAC marking must be affixed to the products.

For information on the country of origin, manufacture year and month, and authorized sales representative (importer) in the CU area of this product, refer to the following:

- Country of origin indication
Check the rating plate of the product. (Refer to [page 12.](#))
Example: MADE IN JAPAN
- Manufactured year and month
Check the SERIAL number indicated on the rating plate of the product. (Refer to [page 12.](#))
- Authorized sales representative (importer) in the CU area
The authorized sales representative (importer) in the CU area is shown below.
Name: Mitsubishi Electric Turkey A.S. Head Office
Address: Serifali Mahallesi Kale Sokak. No:41 34775 Umraniye, Istanbul, Turkey
Phone: +90-216-969-25-00
FAX: +90-216-661-44-47

5.2 Compliance with the UK certification scheme



We declare that this product conforms with the related technical requirements under UK legislation, and affix the UKCA (UK Conformity Assessed) marking on the product.

Approval conditions are the same as those for the EU Directives. Refer to the "Instructions for compliance with the EU Directives" in the document enclosed with the product.

The UKCA marking is used for products sold in the markets of Great Britain (England, Wales, and Scotland) from January 1, 2021 after the departure of the UK from the EU on January 31, 2020.

5.3 Restricted Use of Hazardous Substances in Electronic and Electrical Products

The mark of restricted use of hazardous substances in electronic and electrical products is described as follows based on the "Management Methods for the Restriction of the Use of Hazardous Substances in Electrical and Electronic Products" of the People's Republic of China.

电器电子产品有害物质限制使用标识要求



本产品中所含有的有害物质的名称、含量、含有部件如下表所示。

部件名称 ^{*2}	产品中有害物质的名称及含有的信息表									
	有害物质 ^{*1}									
	铅 (Pb)	汞 (Hg)	镉 (Cd)	六价铬 (Cr(VI))	多溴联苯 (PBBs)	多溴二苯醚 (PBDEs)	邻苯二甲酸二正丁酯 (DBP)	邻苯二甲酸二异丁酯 (DIBP)	邻苯二甲酸丁苯酯 (BBP)	邻苯二甲酸二(2-乙基)己酯 (DEHP)
电路板组件 (包括印刷电路板及其构成的零部件, 如电阻、电容、集成电路、连接器等)、电子部件	×	○	○	○	○	○	○	○	○	○
金属壳体、金属部件	×	○	○	○	○	○	○	○	○	○
树脂壳体、树脂部件	○	○	○	○	○	○	○	○	○	○
螺丝、电线	○	○	○	○	○	○	○	○	○	○

注 1: ○: 表示该有害物质在该部件所有均质材料中的含量均不超出电器电子产品有害物质限制使用国家标准要求。
 ×: 表示该有害物质至少在该部件的某一均质材料中的含量超出电器电子产品有害物质限制使用国家标准要求。
 注 2: 以上未列出的部件, 表明其有害物质含量均不超出电器电子产品有害物质限制使用国家标准要求。

*1 即使表中记载为 ×, 根据产品型号, 也可能会有有害物质的含量为限制值以下的情况。
 *2 根据产品型号, 一部分部件可能不包含在产品中。

5.4 Referenced Standard (Requirement of Chinese standardized law)

This Product is designed and manufactured accordance with following Chinese standards.

Machinery safety	GB/T 16855.1 GB/T 12668.502 GB 28526 GB/T 12668.3
Electrical safety	GB/T 12668.501
EMC	GB/T 12668.3

Warranty

When using this product, make sure to understand the warranty described below.

1. Warranty period and coverage

We will repair any failure or defect (hereinafter referred to as "failure") in our FA equipment (hereinafter referred to as the "Product") arisen during warranty period at no charge due to causes for which we are responsible through the distributor from which you purchased the Product or our service provider. However, we will charge the actual cost of dispatching our engineer for an on-site repair work on request by customer in Japan or overseas countries. We are not responsible for any on-site readjustment and/or trial run that may be required after a defective unit are repaired or replaced.

[Term]

The term of warranty for Product is twelve months after your purchase or delivery of the Product to a place designated by you or eighteen months from the date of manufacture whichever comes first ("Warranty Period"). Warranty period for repaired Product cannot exceed beyond the original warranty period before any repair work.

[Limitations]

- (1) You are requested to conduct an initial failure diagnosis by yourself, as a general rule. It can also be carried out by us or our service company upon your request and the actual cost will be charged.
However, it will not be charged if we are responsible for the cause of the failure.
- (2) This limited warranty applies only when the condition, method, environment, etc. of use are in compliance with the terms and conditions and instructions that are set forth in the instruction manual and user manual for the Product and the caution label affixed to the Product.
- (3) Even during the term of warranty, the repair cost will be charged on you in the following cases;
 - a failure caused by your improper storing or handling, carelessness or negligence, etc., and a failure caused by your hardware or software problem
 - a failure caused by any alteration, etc. to the Product made on your side without our approval
 - a failure which may be regarded as avoidable, if your equipment in which the Product is incorporated is equipped with a safety device required by applicable laws and has any function or structure considered to be indispensable according to a common sense in the industry
 - a failure which may be regarded as avoidable if consumable parts designated in the instruction manual, etc. are duly maintained and replaced
 - any replacement of consumable parts (condenser, cooling fan, etc.)
 - a failure caused by external factors such as inevitable accidents, including without limitation fire and abnormal fluctuation of voltage, and acts of God, including without limitation earthquake, lightning and natural disasters
 - a failure caused by using the emergency drive function
 - a failure generated by an unforeseeable cause with a scientific technology that was not available at the time of the shipment of the Product from our company
 - any other failures which we are not responsible for or which you acknowledge we are not responsible for

2. Term of warranty after the stop of production

- (1) We may accept the repair at charge for another seven (7) years after the production of the product is discontinued. The announcement of the stop of production for each model can be seen in our Sales and Service, etc.
- (2) Please note that the Product (including its spare parts) cannot be ordered after its stop of production.

3. Service in overseas

Our regional FA Center in overseas countries will accept the repair work of the Product; however, the terms and conditions of the repair work may differ depending on each FA Center. Please ask your local FA center for details.

4. Exclusion of loss in opportunity and secondary loss from warranty liability

Regardless of the gratis warranty term, Mitsubishi Electric shall not be liable for compensation to:

- (1) Damages caused by any cause found not to be the responsibility of Mitsubishi Electric.
- (2) Loss in opportunity, lost profits incurred to the user by Failures of Mitsubishi Electric products.
- (3) Special damages and secondary damages whether foreseeable or not, compensation for accidents, and compensation for damages to products other than Mitsubishi Electric products.
- (4) Replacement by the user, maintenance of on-site equipment, start-up test run and other tasks.

5. Change of Product specifications

Specifications listed in our catalogs, manuals or technical documents may be changed without notice.

6. Application and use of the Product

- (1) For the use of our product, its applications should be those that may not result in a serious damage even if any failure or malfunction occurs in product, and a backup or fail-safe function should operate on an external system to product when any failure or malfunction occurs.
- (2) Our product is designed and manufactured as a general purpose product for use at general industries.
Therefore, applications substantially influential on the public interest for such as atomic power plants and other power plants of electric power companies, and also which require a special quality assurance system, including applications for railway companies and government or public offices are not recommended, and we assume no responsibility for any failure caused by these applications when used.

In addition, applications which may be substantially influential to human lives or properties for such as airlines, medical treatments, railway service, incineration and fuel systems, man-operated material handling equipment, entertainment machines, safety machines, etc. are not recommended, and we assume no responsibility for any failure caused by these applications when used. We will review the acceptability of the abovementioned applications, if you agree not to require a specific quality for a specific application. Please contact us for consultation.

Model	FR-D800 TORISETSU SETSUZOKU EIBUN
Model code	1AJ080

mitsubishi electric corporation

HEAD OFFICE: TOKYO BUILDING 2-7-3, MARUNOUCHI, CHIYODA-KU, TOKYO 100-8310, JAPAN