

Programmable Controller



MELSEC iQ-R
series

MELSEC iQ-R
Module Configuration Manual

SAFETY PRECAUTIONS

(Read these precautions before using this product.)

Before using MELSEC iQ-R series programmable controllers, please read the manuals for the product and the relevant manuals introduced in those manuals carefully, and pay full attention to safety to handle the product correctly. If products are used in a different way from that specified by manufacturers, the protection function of the products may not work properly. In this manual, the safety precautions are classified into two levels: "⚠️ WARNING" and "⚠️ CAUTION".

 WARNING	Indicates that incorrect handling may cause hazardous conditions, resulting in death or severe injury.
 CAUTION	Indicates that incorrect handling may cause hazardous conditions, resulting in minor or moderate injury or property damage.

Under some circumstances, failure to observe the precautions given under "⚠️ CAUTION" may lead to serious consequences.

Observe the precautions of both levels because they are important for personal and system safety.

Make sure that the end users read this manual and then keep the manual in a safe place for future reference.

[Design Precautions]

WARNING

- Configure safety circuits external to the programmable controller to ensure that the entire system operates safely even when a fault occurs in the external power supply or the programmable controller. Failure to do so may result in an accident due to an incorrect output or malfunction.
 - (1) Emergency stop circuits, protection circuits, and protective interlock circuits for conflicting operations (such as forward/reverse rotations or upper/lower limit positioning) must be configured external to the programmable controller.
 - (2) When the programmable controller detects an abnormal condition, it stops the operation and all outputs are:
 - Turned off if the overcurrent or overvoltage protection of the power supply module is activated.
 - Held or turned off according to the parameter setting if the self-diagnostic function of the CPU module detects an error such as a watchdog timer error.
 - (3) All outputs may be turned on if an error occurs in a part, such as an I/O control part, where the CPU module cannot detect any error. To ensure safety operation in such a case, provide a safety mechanism or a fail-safe circuit external to the programmable controller. For a fail-safe circuit example, refer to Page 282 General Safety Requirements in this manual.
 - (4) Outputs may remain on or off due to a failure of a component such as a relay and transistor in an output circuit. Configure an external circuit for monitoring output signals that could cause a serious accident.
 - In an output circuit, when a load current exceeding the rated current or an overcurrent caused by a load short-circuit flows for a long time, it may cause smoke and fire. To prevent this, configure an external safety circuit, such as a fuse.
 - Configure a circuit so that the programmable controller is turned on first and then the external power supply. If the external power supply is turned on first, an accident may occur due to an incorrect output or malfunction.
 - Configure a circuit so that the external power supply is turned off first and then the programmable controller. If the programmable controller is turned off first, an accident may occur due to an incorrect output or malfunction.
 - For the operating status of each station after a communication failure, refer to manuals for the network used. For the manuals, please consult your local Mitsubishi representative. Incorrect output or malfunction due to a communication failure may result in an accident.
 - When connecting an external device with a CPU module or intelligent function module to modify data of a running programmable controller, configure an interlock circuit in the program to ensure that the entire system will always operate safely. For other forms of control (such as program modification, parameter change, forced output, or operating status change) of a running programmable controller, read the relevant manuals carefully and ensure that the operation is safe before proceeding. Improper operation may damage machines or cause accidents. When a Safety CPU is used, data cannot be modified while the Safety CPU is in SAFETY MODE.
-

[Design Precautions]

WARNING

- Especially, when a remote programmable controller is controlled by an external device, immediate action cannot be taken if a problem occurs in the programmable controller due to a communication failure. To prevent this, configure an interlock circuit in the program, and determine corrective actions to be taken between the external device and CPU module in case of a communication failure.
- Do not write any data to the "system area" and "write-protect area" of the buffer memory in the module. Also, do not use any "use prohibited" signals as an output signal from the CPU module to each module. Doing so may cause malfunction of the programmable controller system. For the "system area", "write-protect area", and the "use prohibited" signals, refer to the user's manual for the module used. For areas used for safety communications, they are protected from being written by users, and thus safety communications failure caused by data writing does not occur.
- If a communication cable is disconnected, the network may be unstable, resulting in a communication failure of multiple stations. Configure an interlock circuit in the program to ensure that the entire system will always operate safely even if communications fail. Incorrect output or malfunction due to a communication failure may result in an accident. When safety communications are used, an interlock by the safety station interlock function protects the system from an incorrect output or malfunction.

[Precautions for using digital-analog converter modules and high speed digital-analog converter modules]

- Analog outputs may remain on due to a failure of the module. Configure an external interlock circuit for output signals that could cause a serious accident.

[Precautions for using channel isolated analog-digital converter modules (with signal conditioning function)]

- When using the module in the system where a 2-wire transmitter is not connected, use the module where the current input range is set. If the actual system configuration is not consistent with the range setting, it may cause an electric shock.
-

[Design Precautions]

WARNING

[Precautions for using high-speed counter modules and flexible high-speed I/O control modules]

- Outputs may remain on or off due to a failure of a transistor for external output. Configure an external circuit for monitoring output signals that could cause a serious accident.

[Precautions for using flexible high-speed I/O control modules]

- When changing data and operating status of the running module from an external device such as a personal computer connected, configure an interlock circuit external to the programmable controller to ensure that the entire system always operates safely. In addition, before performing online operations, determine corrective actions to be taken between the external device and the module in case of a communication failure due to poor contact of cables.

[Precautions for using positioning modules, Simple Motion modules, and Motion modules]

- Configure safety circuits external to the programmable controller to ensure that the entire system operates safely even when a fault occurs in the external power supply or the programmable controller. Failure to do so may result in an accident due to an incorrect output or malfunction.
 - (1) Machine OPR (Original Point Return) is controlled by two kinds of data: an OPR direction and an OPR speed. Deceleration starts when the near-point dog signal turns on. If an incorrect OPR direction is set, motion control may continue without deceleration. To prevent machine damage caused by this, configure an interlock circuit external to the programmable controller.
 - (2) When the positioning module detects an error, the motion slows down and stops or the motion suddenly stops, depending on the stop group setting in parameter. Set the parameters to meet the specifications of the positioning control system used. In addition, set the OPR parameters and positioning data within the specified setting range.
 - (3) Outputs may remain on or off, or become undefined due to a failure of a component such as an insulation element and transistor in an output circuit, where the positioning module cannot detect any error. In a system where the incorrect outputs could cause a serious accident, configure an external circuit for monitoring output signals.
 - An absolute position restoration by the positioning module may turn off the servo-on signal (servo off) for approximately 60ms + scan time, and the motor may run unexpectedly. If this causes a problem, provide an electromagnetic brake to lock the motor during absolute position restoration.
-

[Design Precautions]

WARNING

[Precautions for using Motion CPUs, Simple Motion modules, and Motion modules]

- Configure safety circuits external to the programmable controller to ensure that the entire system operates safely even when a fault occurs in the external power supply or the programmable controller. Failure to do so may result in an accident due to an incorrect output or malfunction.
- If safety standards (ex., robot safety rules, etc.,) apply to the system using the module, servo amplifier and servo motor, make sure that the safety standards are satisfied.
- Construct a safety circuit externally of the module or servo amplifier if the abnormal operation of the module or servo amplifier differs from the safety directive operation in the system.
- Do not remove the SSCNETⅢ cable while turning on the control circuit power supply of modules and servo amplifier. Do not see directly the light generated from SSCNETⅢ connector of the module or servo amplifier and the end of SSCNETⅢ cable. When the light gets into eyes, you may feel something wrong with eyes. (The light source of SSCNETⅢ complies with class1 defined in IEC 60825-1/JIS C6802.)

[Precautions for using CC-Link IE Controller Network (when optical fiber cables are used)]

- The optical transmitter and receiver of the CC-Link IE Controller Network module use laser diodes (class 1 in accordance with IEC 60825-1: 2014/JIS C6802: 2014). Do not look directly at a laser beam. Doing so may harm your eyes. Also, do not handle the product in ways other than those described in this manual, or do not disassemble or modify the product. Doing so may result in exposure to laser radiation.

[Precautions for using CC-Link system master/local modules]

- To set a refresh device in the module parameters, select the device Y for the remote output (RY) refresh device. If a device other than Y, such as M and L, is selected, the CPU module holds the device status even after its status is changed to STOP. For how to stop data link, refer to the MELSEC iQ-R CC-Link System Master/Local Module User's Manual (Application).

[Precautions for using C Controller modules]

- In the settings of refresh parameters, link output (LY) refresh devices and remote output (RY) refresh devices do not allow the specification of Y. Thus, the CPU module holds the device status even after its status is changed to STOP.
-

[Design Precautions]

WARNING

[Precautions for using I/O modules with diagnostic functions (SIL2 mode)]

- When the I/O module with diagnostic functions detects a fault in the external power supply or programmable controller, it turns off outputs. Configure an external circuit to ensure that the power source of a hazard is shut off by turning off the outputs. Failure to do so may result in an accident.
 - When a load current exceeding the rated current or an overcurrent caused by a load short-circuit flows, the output module with diagnostic functions detects an error and turns off all outputs. Note that if the overcurrent state continues for a long time, it may cause smoke and fire. To prevent this, configure an external safety circuit, such as a fuse.
 - Configure protection circuits, such as a fuse and breaker, external to the output module with diagnostic functions.
 - When a communication failure occurs with CC-Link IE Field Network, the I/O module with diagnostic functions turns off outputs. However, the program does not automatically turn off outputs. Create a program that turns off outputs when a CC-Link IE Field Network error is detected. If CC-Link IE Field Network is restored with outputs on, connected machines may suddenly operate, resulting in an accident.
 - Create an interlock circuit which uses reset buttons so that the system does not restart automatically after executing safety functions and turning off outputs.
-

[Design Precautions]

WARNING

[Precautions for using channel isolated analog-digital converter modules (SIL2 mode)]

- When the R60AD8-G detects a fault in the external power supply or programmable controller, a digital operation value becomes an OFF value (equivalent to 0V/0mA) in all channels. Configure an external circuit to ensure that the power source of a hazard is shut off when a digital operation value of the R60AD8-G is an OFF value (equivalent to 0V/0mA). Failure to do so may result in an accident.
- When a communication failure occurs with CC-Link IE Field Network, a digital operation value of the R60AD8-G becomes an OFF value (equivalent to 0V/0mA). Check the communication status information and configure an interlock circuit in the program to ensure that the entire system will operate safely. Failure to do so may result in an accident due to an incorrect output or malfunction.

[Precautions for using channel isolated digital-analog converter modules (SIL2 mode)]

- When the R60DA8-G detects a fault in the external power supply or programmable controller, an analog output value becomes an OFF value (0V/0mA) in all channels. Configure an external circuit to ensure that the power source of a hazard is shut off when an analog output value of the R60DA8-G is an OFF value (0V/0mA). Failure to do so may result in an accident.
- When a load current exceeding the rated current or an overcurrent caused by a load short-circuit flows, the R60DA8-G detects an error and an analog output value becomes an OFF value (0V/0mA) in all channels. Note that if the overcurrent state continues for a long time, it may cause smoke and fire. To prevent this, configure an external safety circuit, such as a fuse.
- When a communication failure occurs with CC-Link IE Field Network, an analog output value of the R60DA8-G becomes an OFF value (0V/0mA) in all channels. Check the communication status information and configure an interlock circuit in the program to ensure that the entire system will operate safely. Failure to do so may result in an accident due to an incorrect output or malfunction.
- Create an interlock circuit which uses reset buttons so that the system does not restart automatically after safety functions are executed and an analog output value becomes an OFF value (0V/0mA).

[Precautions for using redundant function modules]

- The optical transmitter and receiver of the redundant function module use laser diodes (class 1 in accordance with IEC 60825-1: 2014/JIS C6802: 2014). Do not look directly at a laser beam. Doing so may harm your eyes. Also, do not handle the product in ways other than those described in this manual, or do not disassemble or modify the product. Doing so may result in exposure to laser radiation.

[Precautions for using products in a Class I, Division 2 environment]

- Products with the Cl.I, DIV.2 mark on the rating plate are suitable for use in Class I, Division 2, Groups A, B, C and D hazardous locations, or nonhazardous locations only.
This mark indicates that the product is certified for use in the Class I, Division 2 environment where flammable gases, vapors, or liquids exist under abnormal conditions. When using the products in the Class I, Division 2 environment, observe the following to reduce the risk of explosion.
 - This device is open-type and is to be installed in an enclosure suitable for the environment and require a tool or key to open.
 - Warning - Explosion Hazard - Substitution of any component may impair suitability for Class I, Division 2.
 - Warning - Explosion Hazard - Do not disconnect equipment while the circuit is live or unless the area is known to be free of ignitable concentrations.
 - Do not open the cover of the CPU module and remove the battery unless the area is known to be nonhazardous.
 - All MELSEC iQ-R modules (except base modules) are to be connected to a base module only.

[Design Precautions]

WARNING

[Precautions for using Process CPUs]

- If the redundant system fails, control of the entire system may not be maintained depending on the failure mode. The control may not be maintained in the following case either: An error in an extension base unit or in a module on an extension base unit is detected and causes a stop error of the control system, system switching occurs, and a similar error is detected and causes a stop error of the standby system (new control system). To ensure that the entire system operates safely even in these cases, configure safety circuits external to the programmable controller.

[Precautions for using SIL2 Process CPUs]

- When the programmable controller compliant with SIL2 (IEC 61508) detects a fault in the external power supply or itself, it turns off all outputs in the safety system. Configure an external circuit to ensure that the power source of a hazard is shut off by turning off the outputs. Failure to do so may result in an accident.
 - Configure short current protection circuits for safety relays and protection circuits, such as a fuse and breaker, external to the programmable controller.
 - When a load current exceeding the rated current or an overcurrent caused by a load short-circuit flows, modules operating in SIL2 mode detect an error and turn off all outputs. Note that if the overcurrent state continues for a long time, it may cause smoke and fire. To prevent this, configure an external safety circuit, such as a fuse.
 - When changing data and operating status, and modifying program of the running programmable controller from an external device such as a personal computer connected to the SIL2 Process CPU, configure an interlock circuit in the program or external to the programmable controller to ensure that the entire system always operates safely. In addition, before performing online operations, determine corrective actions to be taken between the external device and SIL2 Process CPU in case of a communication failure due to poor contact of cables.
 - Do not use any "use prohibited" signals of modules as an I/O signal since they are used by the system. Do not write any data to the "use prohibited" areas in the buffer memory of modules. For the "use prohibited" signals, refer to the user's manual for each module. Do not turn on or off these signals on a program since normal operations cannot be guaranteed. Doing so may cause malfunction of the programmable controller system.
 - When a module operating in SIL2 mode detects an error in a safety communication path, it turns off outputs. However, the program does not automatically turn off outputs. Create a program that turns off outputs when an error is detected in a safety communication path. If safety communications are restored with outputs on, connected devices may suddenly operate, resulting in an accident.
 - Create an interlock circuit which uses reset buttons so that the system does not restart automatically after executing safety functions and turning off outputs.
 - In the case of a communication failure in the network, the status of the error station will be as follows:
 - (1) Inputs from remote stations are not refreshed.
 - (2) All outputs from remote stations are turned off.Check the communication status information and configure an interlock circuit in the program to ensure that the entire system will operate safely. Failure to do so may result in an accident due to an incorrect output or malfunction.
 - Outputs may remain on or off due to a failure of an output module operating in SIL2 mode. Configure an external circuit for monitoring output signals that could cause a serious accident.
-

[Design Precautions]

WARNING

[Precautions for using Safety CPUs]

- When the safety programmable controller detects a fault in the external power supply or itself, it turns off all outputs in the safety system. Configure an external circuit to ensure that the power source of a hazard is shut off by turning off the outputs. Failure to do so may result in an accident.
 - Configure short current protection circuits for safety relays and protection circuits, such as a fuse and breaker, external to the safety programmable controller.
 - When a load current exceeding the rated current or an overcurrent caused by a load short-circuit flows, the CC-Link IE Field Network remote I/O module (with safety functions) detects an error and turns off all outputs. Note that if the overcurrent state continues for a long time, it may cause smoke and fire. To prevent this, configure an external safety circuit, such as a fuse.
 - When changing data and operating status, and modifying program of the running safety programmable controller from an external device such as a personal computer connected to the Safety CPU, configure an interlock circuit in the program or external to the safety programmable controller to ensure that the entire system always operates safely. In addition, before performing online operations, determine corrective actions to be taken between the external device and Safety CPU in case of a communication failure due to poor contact of cables.
 - Do not use any "use prohibited" signals as a remote I/O signal since they are used by the system. Do not write any data to the "use prohibited" areas in the remote register. For the "use prohibited" signals, refer to the MELSEC iQ-R CC-Link IE Field Network User's Manual (Application). Do not turn on or off these signals on a program since normal operations cannot be guaranteed. Doing so may cause malfunction of the programmable controller system.
 - When the CC-Link IE Field Network remote I/O module (with safety functions) detects a CC-Link IE Field Network error, it turns off outputs. However, the program does not automatically turn off outputs. Create a program that turns off outputs when a CC-Link IE Field Network error is detected. If CC-Link IE Field Network is restored with outputs on, connected machines may suddenly operate, resulting in an accident.
 - Ensure that the system does not restart automatically after executing safety functions and turning off outputs. Create a circuit that does not allow the system to restart until an intentional start has been manually issued by an operator.
 - In the case of a communication failure in the network, the CPU module recognizes the communication destination station as an error station. The error station will be as follows:
 - (1) All safety inputs from the error station to the CPU module are not refreshed.
 - (2) All safety outputs from the error station to external devices are turned off because the CPU module does not communicate with the error station.Check the communication status information and configure an interlock circuit in the program to ensure that the entire system will operate safely. Failure to do so may result in an accident due to an incorrect output or malfunction.
 - Outputs may remain on or off due to a failure of the CC-Link IE Field Network remote I/O module (with safety functions). Configure an external circuit for monitoring output signals that could cause a serious accident.
-

[Design Precautions]

WARNING

[Precautions for using remote head modules]

- Configure safety circuits external to the remote head module to ensure that the entire system operates safely even when a fault occurs in the external power supply or the remote head module. Failure to do so may result in an accident due to an incorrect output or malfunction.
 - (1) Emergency stop circuits, protection circuits, and protective interlock circuits for conflicting operations (such as forward/reverse rotations or upper/lower limit positioning) must be configured external to the remote head module.
 - (2) When the remote head module detects an abnormal condition, outputs are:
 - Held or turned off according to the parameter setting of each module mounted on the main base unit or extension base unit if the self-diagnostic function of the remote head module detects an error such as a watchdog timer error.
 - (3) All outputs may be turned on if an error occurs in a part, such as an I/O control part, where the remote head module cannot detect any error. To ensure safety operation in such a case, provide a safety mechanism or a fail-safe circuit external to the remote head module. For a fail-safe circuit example, refer to Page 282 General Safety Requirements in this manual.
 - Configure a circuit so that the remote head module is turned on first and then the external power supply. If the external power supply is turned on first, an accident may occur due to an incorrect output or malfunction.
 - When connecting an external device with a remote head module to modify data of a running remote head module, configure an interlock circuit in the program of the master station to ensure that the entire system will always operate safely. For other forms of control (such as parameter change, forced output, or operating status change) of a running remote head module, read the relevant manuals carefully and ensure that the operation is safe before proceeding. Improper operation may damage machines or cause accidents.
 - Especially, when a remote head module is remotely controlled by an external device, immediate action cannot be taken if a problem occurs in the remote head module due to a communication failure. To prevent this, configure an interlock circuit in the program of the master station, and determine corrective actions to be taken between the external device and remote head module in case of a communication failure.
 - Do not write any data to the buffer memory in the remote head module. Doing so may cause malfunction of the programmable controller system.
 - Do not write any data from the remote head module to the "system area" and "write-protect area" of the buffer memory in each module. Also, do not use any "use prohibited" signals as an output signal from the remote head module to each module. Doing so may cause malfunction of the programmable controller system. For the "system area", "write-protect area", and the "use prohibited" signals, refer to the user's manual for the module used.
-

[Design Precautions]

WARNING

[Precautions for using AnyWireASLINK master modules]

- An AnyWireASLINK system has no control function for ensuring safety.

[Precautions for using DeviceNet master/slave modules]

- If a communication failure occurs on a DeviceNet network, faulty nodes will behave as (1) and (2) below. Configure an interlock circuit in the program using the communication status information of slave nodes and provide a safety mechanism external to the slave node to ensure that the entire system will operate safely.
 - (1) The master node (RJ71DN91) holds input data which had been received from slave nodes before the communication failure occurred.
 - (2) Whether output signals of a slave node are turned off or held is determined by the specifications of slave nodes or the parameter settings of the master node. When the RJ71DN91 is used as a slave node, it holds input data that had been received from the master node before the communication failure occurred.

[Precautions for using PROFIBUS-DP modules]

- If a communication failure occurs with a PROFIBUS-DP network, the operating status of each station is as follows:
 - (1) The DP-Master holds the input data when the communication failure occurs.
 - (2) If the DP-Master goes down, the output status of each DP-Slave depends on the parameter setting of the DP-Master.
 - (3) If a DP-Slave goes down, the output status of other DP-Slaves depends on the parameter setting of the DP-Master.

Check the diagnostic information and configure an interlock circuit in the program to ensure that the entire system will operate safely. Failure to do so may result in an accident due to an incorrect output or malfunction.

- The assignments of I/O signals and buffer memory areas differ depending on whether the RJ71PB91V is used as the DP-Master or a DP-Slave. Configure an interlock circuit in the program to ensure that the program does not run with the incorrect station type.
 - If a stop error occurs in the CPU module, the operating status of the DP-Master is as follows. In a redundant system, however, the operation is the same as when "CPU Error Output Mode Setting" is set to "Hold" regardless of its setting value.
 - (1) When "CPU Error Output Mode Setting" is set to "Clear"
 - I/O data exchanges with DP-Slaves are interrupted.
 - Output data in the buffer memory of the DP-Master are cleared and not sent.
 - Input data which have been received from DP-Slaves when a stop error occurs in the CPU module are held in the buffer memory of the DP-Master.
 - (2) When "CPU Error Output Mode Setting" is set to "Hold"
 - I/O data exchanges with DP-Slaves are continued.
 - Output data which have been stored in the buffer memory of the DP-Master when a stop error occurs in the CPU module are held and sent to DP-Slaves.
 - Data in the buffer memory of the DP-Master are updated with input data received from DP-Slaves.
-

[Design Precautions]

WARNING

- If a stop error occurs in the CPU module, the operating status of DP-Slaves is as follows:
 - (1) When "CPU Error Output Mode Setting" is set to "Clear"
 - Input data to be sent from DP-Slaves to the DP-Master are cleared.
 - Output data which have been received from the DP-Master when a stop error occurs in the CPU module are held in the buffer memory of DP-Slaves.
 - (2) When "CPU Error Output Mode Setting" is set to "Hold"
 - Input data to be sent from DP-Slaves to the DP-Master when a stop error occurs in the CPU module are held.
 - Output data which have been received from the DP-Master when a stop error occurs in the CPU module are held in the buffer memory of DP-Slaves.

[Precautions for using laser displacement sensor control modules]

- Provide safety measures such as a dual safety mechanism when the module is used for applications that have the possibility of causing physical injury or serious damage.

[Precautions for using EtherNet/IP network interface modules]

- For the operating status of each EtherNet/IP device after a communication failure, refer to the MELSEC iQ-R EtherNet/IP Network Interface Module User's Manual (Application). Incorrect output or malfunction due to a communication failure may result in an accident.
- Configure an interlock circuit in the program to ensure that the entire system will always operate safely even if communications fail in multiple EtherNet/IP devices. Failure to do so may result in an accident due to an incorrect output or malfunction.

[Precautions for using MELSECWinCPU modules]

- The execution of a user application may be delayed on Windows[®] 10 IoT Enterprise LTSC 2019 due to the effect of operating system scheduling. Do not use this product in a situation that requires a fixed-cycle operation and a high-speed response.

In addition, the execution of a user application may be delayed when any of the following operations is performed:

- Connecting or disconnecting an HDMI connector cable
- Mounting or removing a device to/from a USB connector
- Inserting an SD memory card into the SD memory card slot
- Unlocking a Windows lock screen
- Signing in to Windows
- Signing out of Windows
- Remote desktop connection
- Starting other applications

[Precautions for using MELSECNET/H network modules]

- If a coaxial cable is disconnected, the network may be unstable, resulting in a communication failure of multiple stations. Configure an interlock circuit in the sequence program to ensure that the entire system will always operate safely even if communications fail in multiple stations. Incorrect output or malfunction due to a communication failure may result in an accident.
-

[Design Precautions]

WARNING

[Precautions for using I/O modules (with safety functions)]

- When the I/O module (with safety functions) detects an error in an external power supply or a failure in the module, it turns off the outputs. Configure an external circuit to ensure that the power source of a hazard is shut off by turning off the outputs. Failure to do so may result in an accident due to an incorrect output or malfunction.
 - When a load current exceeding the rated current or an overcurrent caused by a load short-circuit flows, the I/O module (with safety functions) defines it as a fault and turns off the outputs. Note that if the overcurrent state continues for a long time, it may cause smoke and fire. To prevent this, configure an external safety circuit, such as a fuse.
 - At the start-up of the system, if the external power supply is short-circuited by the output wiring of the I/O module (with safety functions), or if the external power supply is connected with a wrong polarity, a load may turn on just after the power-on. Configure an interlock circuit to ensure that the entire system will always operate safely.
 - When a safety I/O refresh error (error code: 1A03H to 1A09H) occurs in the I/O module (with safety functions), the error module will be as follows. Check the safety I/O refresh status and configure an interlock circuit in the program to ensure that the entire system will operate safely. Failure to do so may result in an accident due to an incorrect output or malfunction.
 - (1) All data that are output from the I/O module (with safety functions) are turned off.
 - (2) All data that are sent from the I/O module (with safety functions) to the Safety CPU are turned off.
 - Do not write any data to the "system area" and "write-prohibited area" of the buffer memory in the module. Also, do not use any "use prohibited" signals as an I/O signal. If these operations are performed, the correct operation of the module cannot be guaranteed. For the "system area", "write-prohibited area", and the "use prohibited" signals, refer to MELSEC iQ-R I/O Module (With Safety Functions) User's Manual.
 - To satisfy SIL3, Category 4 PLe, use input devices with normally closed contacts. Inputs using the devices with normally open contacts do not satisfy SIL3, Category 4 PLe.
 - When "Safety I/O refresh continues (Without output interlock)" is selected for the operation setting of external power supply voltage error detection, configure an external interlock circuit for the safety outputs to prevent unintended restart.
-

[Design Precautions]

CAUTION

- Do not install the control lines or communication cables together with the main circuit lines or power cables. Doing so may result in malfunction due to electromagnetic interference. Keep a distance of 100mm or more between those cables.
- During control of an inductive load such as a lamp, heater, or solenoid valve, a large current (approximately ten times greater than normal) may flow when the output is turned from off to on. Therefore, use a module that has a sufficient current rating.
- After the CPU module is powered on or is reset, the time taken to enter the RUN status varies depending on the system configuration, parameter settings, and/or program size. Design circuits so that the entire system will always operate safely, regardless of the time.
- Do not power off the programmable controller or reset the CPU module while the settings are being written. Doing so will make the data in the flash ROM and SD memory card undefined. The values need to be set in the buffer memory and written to the flash ROM and SD memory card again. Doing so also may cause malfunction or failure of the module.
- When changing the operating status of the CPU module from external devices (such as the remote RUN/STOP functions), select "Do Not Open by Program" for "Opening Method" of "Module Parameter". If "Open by Program" is selected, an execution of the remote STOP function causes the communication line to close. Consequently, the CPU module cannot reopen the line, and external devices cannot execute the remote RUN function.
- Power the base unit and the modules mounted on the base unit from a power supply that satisfies SELV (Safety Extra Low Voltage) and LIM (Limited Energy Circuit) or satisfies UL 1310 Class 2.

[Precautions for using digital-analog converter modules and high speed digital-analog converter modules]

- Power on or off the external power supply while the programmable controller is on. Failure to do so may result in incorrect output or malfunction.
- At on/off of the power or external power supply, or at the output range switching, a voltage may occur or a current may flow between output terminals for a moment. In this case, start the control after analog outputs become stable.

[Precautions for using high-speed counter modules and flexible high-speed I/O control modules]

- Do not install the control lines or communication cables together with the main circuit lines or power cables. Doing so may result in malfunction due to noise. Keep a distance of 150mm or more between those cables.

[Precautions for using SIL2 Process CPUs]

- Do not install the control lines or communication cables together with the main circuit lines or power cables. Doing so may result in malfunction due to noise. Keep a distance of 100mm or more between those cables.
 - When selecting external devices to be connected to modules that operate in SIL2 mode, consider the maximum inrush current described in the user's manual for each module. Exceeding the maximum inrush current may cause malfunction or failure of the module.
-

[Design Precautions]

CAUTION

[Precautions for using Safety CPUs]

- When selecting external devices to be connected to the CC-Link IE Field Network remote I/O module (with safety functions), consider the maximum inrush current described in the CC-Link IE Field Network Remote I/O Module (With Safety Functions) User's Manual. Exceeding the maximum inrush current may cause malfunction or failure of the module.

[Precautions for using remote head modules]

- After the remote head module is powered on or is reset, the time taken to enter the RUN status varies depending on the system configuration and/or parameter settings. Design circuits so that the entire system will always operate safely, regardless of the time.
- Do not power off or reset the remote head module while the parameters are being written. Doing so may cause malfunction or failure of the module.

[Precautions for using laser displacement sensor control modules]

- Do not use the laser displacement sensor outside of its specifications (such as ratings or environments). Doing so may result in overheating or smoke.
- Do not disassemble or modify the modules. Doing so may cause failure, malfunction, injury, or a fire.
- Do not touch any terminal while power is on. Doing so will cause electric shock or malfunction.

[Precautions for using MELSECWinCPU modules]

- After the MELSECWinCPU module is powered on or the hardware or a bus is reset, the time taken to enter the READY status varies depending on the system configuration, parameter settings, and/or program size. Design circuits so that the entire system will always operate safely, regardless of the time.

[Precautions for using C Controller modules]

- After a C Controller module is powered on or is reset, the time taken to enter the RUN status varies depending on the system configuration, parameter settings, program size, and/or connection status with external devices. Design circuits so that the entire system will always operate safely, regardless of the time.

[Precautions for using I/O modules (with safety functions)]

- Select the external devices to be connected to the module by referring to the performance specifications in the MELSEC iQ-R I/O Module (With Safety Functions) User's Manual and considering the maximum inrush current. Connecting a device exceeding the maximum inrush current may cause malfunction or failure of the module.
-

[Security Precautions]

WARNING

- To maintain the security (confidentiality, integrity, and availability) of the programmable controller and the system against unauthorized access, denial-of-service (DoS) attacks, computer viruses, and other cyberattacks from external devices via the network, take appropriate measures such as firewalls, virtual private networks (VPNs), and antivirus solutions.
-

[Installation Precautions]

WARNING

- Shut off the external power supply (all phases) used in the system before mounting or removing the module. Failure to do so may result in electric shock or cause the module to fail or malfunction.

[Precautions for using C Controller modules]

- When mounting a C Controller module, make sure to attach the included connector cover for a base unit to the module connector of the second slot to prevent entrance of foreign material such as dust.
-

[Installation Precautions]

CAUTION

- Use the programmable controller in an environment that meets Page 136 General Specifications in this manual. Failure to do so may result in electric shock, fire, malfunction, or damage to or deterioration of the product.
- To mount a module, place the concave part(s) located at the bottom onto the guide(s) of the base unit, and push in the module until the hook(s) located at the top snaps into place. Incorrect interconnection may cause malfunction, failure, or drop of the module.
- To mount a module with no module fixing hook, place the concave part(s) located at the bottom onto the guide(s) of the base unit, push in the module, and fix it with screw(s). Incorrect interconnection may cause malfunction, failure, or drop of the module.
- When using the programmable controller in an environment of frequent vibrations, fix the module with a screw.
- Tighten the screws within the specified torque range. Undertightening can cause drop of the component or wire, short circuit, or malfunction. Overtightening can damage the screw and/or module, resulting in drop, short circuit, or malfunction. For the specified torque range, refer to Page 192 Precautions and Page 204 Handling precautions in this manual.
- When using an extension cable, connect it to the extension cable connector of the base unit securely. Check the connection for looseness. Poor contact may cause malfunction.
- When using an SD memory card, fully insert it into the SD memory card slot. Check that it is inserted completely. Poor contact may cause malfunction.
- Securely insert an extended SRAM cassette or a battery-less option cassette into the cassette connector of the CPU module. After insertion, close the cassette cover and check that the cassette is inserted completely. Poor contact may cause malfunction.
- Beware that the module could be very hot while power is on and immediately after power-off.
- Do not directly touch any conductive parts and electronic components of the module, SD memory card, extended SRAM cassette, battery-less option cassette, or connector. Doing so can cause malfunction or failure of the module.

[Precautions for using Safety CPUs]

- Use the CC-Link IE Field Network remote I/O module (with safety functions) and CC-Link IE Field Network remote I/O module in an environment that meets the general specifications in the corresponding manuals (CC-Link IE Field Network Remote I/O Module (With Safety Functions) User's Manual and CC-Link IE Field Network Remote I/O Module User's Manual). Failure to do so may result in electric shock, fire, malfunction, or damage to or deterioration of the product.
 - Securely fix the CC-Link IE Field Network remote I/O module (with safety functions) and CC-Link IE Field Network remote I/O module with a DIN rail or module fixing screws. Tighten the screws within the specified torque range. Undertightening can cause drop of the screw, short circuit, or malfunction. Overtightening can damage the screw and/or module, resulting in drop, short circuit, or malfunction.
-

[Installation Precautions]

CAUTION

[Precautions for using MELSECWinCPU modules]

- Use a CFast card in an environment that meets Page 136 General Specifications in this manual. Failure to do so may result in electric shock, fire, malfunction, or damage to or deterioration of the product.
- When using an SD memory card and CFast card, fully insert them into the card slots. Check that they are inserted completely. Poor contact may cause malfunction.
- Do not directly touch any conductive parts and electronic components of the module, SD memory card, CFast card, or connector. Doing so can cause malfunction or failure of the module.

[Precautions for using I/O modules (with safety functions)]

- After the first use of the product, do not connect/remove the connector more than 50 times (IEC 61131-2/JIS B 3502 compliant). Exceeding the limit may cause malfunction.
 - Connect each connection cable to the connector securely. Poor contact may cause malfunction.
-

[Wiring Precautions]

WARNING

- Shut off the external power supply (all phases) used in the system before installation and wiring. Failure to do so may result in electric shock or cause the module to fail or malfunction.
- After installation and wiring, attach a blank cover module (RG60) to each empty slot before powering on the system for operation. Also, attach an extension connector protective cover^{*1} to each unused extension cable connector as necessary. Directly touching any conductive parts of the connectors while power is on may result in electric shock.

*1 For details, please consult your local Mitsubishi Electric representative.

[Precautions for using CC-Link IE TSN (when optical fiber cables are used)]

- The optical transmitter and receiver of the CC-Link IE TSN master/local module (1000BASE-SX model) use laser diodes (class 1 in accordance with IEC 60825-1: 2014/JIS C6802: 2014). Do not look directly at a laser beam. Doing so may harm your eyes. Also, do not handle the product in ways other than those described in this manual, or do not disassemble or modify the product. Doing so may result in exposure to laser radiation.

[Precautions for using flexible high-speed I/O control modules]

- When connecting a differential output terminal to a differential receiver of a drive unit, connect the high-speed output common terminal to the differential receiver common terminal of the drive unit. Failure to do so may cause the module to fail or malfunction because of the potential difference that occurs between the high-speed output common terminal and the differential receiver common terminal.
-

[Wiring Precautions]

CAUTION

- Individually ground the FG and LG terminals of the programmable controller with a ground resistance of 100 ohms or less. Failure to do so may result in electric shock or malfunction.
 - Use applicable solderless terminals and tighten them within the specified torque range. If any spade solderless terminal is used, it may be disconnected when the terminal screw comes loose, resulting in failure.
 - Check the rated voltage and signal layout before wiring to the module, and connect the cables correctly. Connecting a power supply with a different voltage rating or incorrect wiring may cause fire or failure.
 - Connectors for external devices must be crimped or pressed with the tool specified by the manufacturer, or must be correctly soldered. Incomplete connections may cause short circuit, fire, or malfunction.
 - Securely connect the connector to the module. Poor contact may cause malfunction.
 - Do not install the control lines or communication cables together with the main circuit lines or power cables. Doing so may result in malfunction due to noise. Keep a distance of 100mm or more between those cables. (Except for the RJ71GN11-SX)
 - Place the cables in a duct or clamp them. If not, dangling cables may swing or inadvertently be pulled, resulting in malfunction or damage to modules or cables.
In addition, the weight of the cables may put stress on modules in an environment of strong vibrations and shocks.
Do not clamp the extension cables with the jacket stripped. Doing so may change the characteristics of the cables, resulting in malfunction.
 - Check the interface type and correctly connect the cable. Incorrect wiring (connecting the cable to an incorrect interface) may cause failure of the module and external device.
 - Tighten the terminal screws or connector screws within the specified torque range. Undertightening can cause drop of the screw, short circuit, fire, or malfunction. Overtightening can damage the screw and/or module, resulting in drop, short circuit, fire, or malfunction.
 - When disconnecting the cable from the module, do not pull the cable by the cable part. For the cable with connector, hold the connector part of the cable. For the cable connected to the terminal block, loosen the terminal screw. Pulling the cable connected to the module may result in malfunction or damage to the module or cable.
 - When wiring, shield the module using a cover or similar means to prevent foreign matter such as dust or wire chips from entering the module. Such foreign matter can cause a fire, failure, or malfunction. Remove the shield for heat dissipation before operating the system.
 - When a protective film is attached to the top of the module, remove it before system operation. If not, inadequate heat dissipation of the module may cause a fire, failure, or malfunction.
-

[Wiring Precautions]

CAUTION

- Programmable controllers must be installed in control panels. Connect the main power supply to the power supply module in the control panel through a relay terminal block. Wiring and replacement of a power supply module must be performed by qualified maintenance personnel with knowledge of protection against electric shock. For wiring, refer to Page 179 Wiring in this manual.
- For Ethernet cables to be used in the system, select the ones that meet the specifications in the user's manual for the module used. If not, normal data transmission is not guaranteed.

[Precautions for using channel isolated analog-digital converter modules, channel isolated digital-analog converter modules, channel isolated RTD input modules, temperature control modules, and channel isolated analog-digital converter modules (with signal conditioning function)]

- Individually ground the shielded cables of the programmable controller with a ground resistance of 100 ohms or less. Failure to do so may result in electric shock or malfunction.

[Precautions for using channel isolated thermocouple input modules]

- Individually ground the shielded cables of the programmable controller with a ground resistance of 100 ohms or less. Failure to do so may result in electric shock or malfunction.
- Do not place the module near a device that generates magnetic noise.

[Precautions for using high-speed counter modules and flexible high-speed I/O control modules]

- Do not install the control lines or communication cables together with the main circuit lines or power cables. Doing so may result in malfunction due to noise. Keep a distance of 150mm or more between those cables.
- Ground the shielded cables on the encoder side (relay box) with a ground resistance of 100 ohms or less. Failure to do so may cause malfunction.

[Precautions for using channel isolated pulse input modules]

- Do not install the control lines or communication cables together with the main circuit lines or power cables. Doing so may result in malfunction due to noise. Keep a distance of 150mm or more between those cables.
- Ground the shielded cables with a ground resistance of 100 ohms or less. Failure to do so may cause malfunction.

[Precautions for using CC-Link IE TSN (when optical fiber cables are used)]

- For optical fiber cables to be used in the system, select the ones that meet the specifications in the MELSEC iQ-R CC-Link IE TSN User's Manual (Startup). If not, normal data transmission is not guaranteed.

[Precautions for using CC-Link IE Controller Network (when optical fiber cables are used)]

- For optical fiber cables to be used in the system, select the ones that meet the specifications in the MELSEC iQ-R Ethernet/CC-Link IE User's Manual (Startup). If not, normal data transmission is not guaranteed.

[Precautions for using CC-Link system master/local modules]

- Use Ver.1.10-compatible CC-Link dedicated cables in a CC-Link system. If not, the performance of the CC-Link system is not guaranteed. For the station-to-station cable length and the maximum overall cable length, follow the specifications in the MELSEC iQ-R CC-Link System Master/Local Module User's Manual (Startup). If not, normal data transmission is not guaranteed.
-

[Wiring Precautions]

CAUTION

[Precautions for using redundant function modules]

- For tracking cables to be used in the system, select the ones that meet the specifications in the MELSEC iQ-R CPU Module User's Manual (Startup). If not, normal data transmission is not guaranteed.

[Precautions for using AnyWireASLINK master modules]

- Do not apply the 24VDC power before wiring the entire AnyWireASLINK system. If the power is applied before wiring, normal data transmission is not guaranteed.
- Connect a 24VDC external power supply to the device(s) in an AnyWireASLINK system.

[Precautions for using laser displacement sensor control modules]

- Do not apply the 24VDC power before connecting a sensor head. If the power is applied before wiring, normal data transmission is not guaranteed.

[Precautions for using MELSECNET/H network modules]

- Connectors for external devices and connectors for coaxial cables must be crimped or pressed with the tool specified by the manufacturer, or must be correctly soldered. Incomplete connections may cause short circuit, fire, or malfunction.
- Properly solder the parts of a soldering-type coaxial cable connector. Incomplete soldering may result in malfunction.
- Crimp the parts of a crimping-type coaxial cable connector with proper force at a proper position. Failure to do so may cause drop of the cable or malfunction.
- For optical fiber cables and coaxial cables to be used in the system, select the ones that meet the specifications in the MELSEC iQ-R MELSECNET/H Network Module User's Manual (Startup). If not, normal data transmission is not guaranteed.

[Precautions for using I/O modules (with safety functions)]

- When an overcurrent caused by an error of an external device or a failure of the module flows for a long time, it may cause smoke and fire. To prevent this, configure an external safety circuit, such as a fuse.
 - Programmable controllers must be installed in control panels. Wiring and replacement of the power supply module and the I/O module (with safety functions) must be performed by qualified maintenance personnel with knowledge of protection against electric shock. For wiring of the power supply module, refer to Page 179 Wiring in this manual. For wiring of the I/O module (with safety functions), refer to the MELSEC iQ-R I/O Module (With Safety Functions) User's Manual.
-

[Startup and Maintenance Precautions]

WARNING

- Do not touch any terminal while power is on. Doing so will cause electric shock or malfunction.
- Correctly connect the battery connector. Do not charge, disassemble, heat, short-circuit, solder, or throw the battery into the fire. Also, do not expose it to liquid or strong shock. Doing so will cause the battery to produce heat, explode, ignite, or leak, resulting in injury and fire.
- Shut off the external power supply (all phases) used in the system before cleaning the module or retightening the terminal screws, connector screws, or module fixing screws. Failure to do so may result in electric shock.

[Precautions for using I/O modules (with safety functions)]

- Shut off the external power supply (all phases) used in the system before cleaning the module. Failure to do so may result in electric shock.
-

[Startup and Maintenance Precautions]

CAUTION

- When connecting an external device with a CPU module or intelligent function module to modify data of a running programmable controller, configure an interlock circuit in the program to ensure that the entire system will always operate safely. For other forms of control (such as program modification, parameter change, forced output, or operating status change) of a running programmable controller, read the relevant manuals carefully and ensure that the operation is safe before proceeding. Improper operation may damage machines or cause accidents.
 - Especially, when a remote programmable controller is controlled by an external device, immediate action cannot be taken if a problem occurs in the programmable controller due to a communication failure. To prevent this, configure an interlock circuit in the program, and determine corrective actions to be taken between the external device and CPU module in case of a communication failure.
 - Do not disassemble or modify the modules. Doing so may cause failure, malfunction, injury, or a fire.
 - Use any radio communication device such as a cellular phone or PHS (Personal Handy-phone System) 25cm or more away in all directions from the programmable controller. Failure to do so may cause malfunction.
 - Shut off the external power supply (all phases) used in the system before mounting or removing the module. Failure to do so may cause the module to fail or malfunction.
 - Tighten the screws within the specified torque range. Undertightening can cause drop of the component or wire, short circuit, or malfunction. Overtightening can damage the screw and/or module, resulting in drop, short circuit, or malfunction.
-

[Startup and Maintenance Precautions]

CAUTION

- After the first use of the product, do not perform each of the following operations more than 50 times (IEC 61131-2/JIS B 3502 compliant).
Exceeding the limit may cause malfunction.
 - Mounting/removing the module to/from the base unit
 - Inserting/removing the extended SRAM cassette or battery-less option cassette to/from the CPU module
 - Mounting/removing the terminal block to/from the module
 - Connecting/disconnecting the extension cable to/from the base unit
 - After the first use of the product, do not insert/remove the SD memory card to/from the CPU module more than 500 times. Exceeding the limit may cause malfunction.
 - Do not touch the metal terminals on the back side of the SD memory card. Doing so may cause malfunction or failure of the module.
 - Do not touch the integrated circuits on the circuit board of an extended SRAM cassette or a battery-less option cassette. Doing so may cause malfunction or failure of the module.
 - Do not drop or apply shock to the battery to be installed in the module. Doing so may damage the battery, causing the battery fluid to leak inside the battery. If the battery is dropped or any shock is applied to it, dispose of it without using.
 - Startup and maintenance of a control panel must be performed by qualified maintenance personnel with knowledge of protection against electric shock. Lock the control panel so that only qualified maintenance personnel can operate it.
 - Before handling the module, touch a conducting object such as a grounded metal to discharge the static electricity from the human body. Wearing a grounded antistatic wrist strap is recommended. Failure to discharge the static electricity may cause the module to fail or malfunction.
 - After unpacking, eliminate static electricity from the module to prevent electrostatic discharge from affecting the module. If an electrostatically charged module comes in contact with a grounded metal object, a sudden electrostatic discharge of the module may cause failure.
For details on how to eliminate static electricity from the module, refer to the following.
Safety Precautions For Static Electricity Before Using MELSEC MX Controller MX-R Model and MELSEC iQ-R Series Models (FA-A-0368)
 - Use a clean and dry cloth to wipe off dirt on the module.
-

[Startup and Maintenance Precautions]

CAUTION

[Precautions for using SIL2 Process CPUs]

- When performing online operations to the running SIL2 Process CPU such as program modification, device test, and operating status change (for example, from RUN to STOP) of the running programmable controller from an external device such as a personal computer connected, read relevant manuals carefully and ensure the safety before operation. The operations must be performed by qualified operators following the operating procedure that is predetermined at the design stage. Modifying a program while the SIL2 Process CPU is running (the online change) may cause corruption of the program depending on operating conditions. Fully understand the precautions described in the GX Works3 Operating Manual before operation.

[Precautions for using flexible high-speed I/O control modules]

- When performing online operations of the running module from an external device such as a personal computer connected, read the relevant manuals carefully and ensure that the operation is safe before proceeding.
- Before changing any setting of the module, read the relevant manuals carefully, ensure the safety, and change the operating status of the CPU module to STOP. Especially when operating the module in the network system, ensure the safety thoroughly because controlled machines are likely to be moved inadvertently. Improper operation may damage machines or cause accidents.

[Precautions for using positioning modules, Motion CPUs, Simple Motion modules, and Motion modules]

- Before testing the operation, set a low speed value for the speed limit parameter so that the operation can be stopped immediately upon occurrence of a hazardous condition.
- Confirm and adjust the program and each parameter before operation. Unpredictable movements may occur depending on the machine.

[Precautions for using Motion CPUs, Simple Motion modules, and Motion modules]

- When using the absolute position system function, on starting up, and when the module or absolute position motor has been replaced, always perform a home position return.
 - Before starting the operation, confirm the brake function.
 - Do not perform a megger test (insulation resistance measurement) during inspection.
 - After maintenance and inspections are completed, confirm that the position detection of the absolute position detection function is correct.
 - Lock the control panel and prevent access to those who are not certified to handle or install electric equipment.
-

[Startup and Maintenance Precautions]

CAUTION

[Precautions for using remote head modules]

- When connecting an external device with a remote head module to modify data of a running programmable controller, configure an interlock circuit in the program of the master station to ensure that the entire system will always operate safely. For other forms of control (such as parameter change, forced output, or operating status change) of a running remote head module, read the relevant manuals carefully and ensure that the operation is safe before proceeding. Improper operation may damage machines or cause accidents.
- Especially, when a remote head module is remotely controlled by an external device, immediate action cannot be taken if a problem occurs in the remote head module due to a communication failure. To prevent this, configure an interlock circuit in the program of the master station, and determine corrective actions to be taken between the external device and remote head module in case of a communication failure.

[Precautions for using MELSECWinCPU modules]

- Do not disassemble or modify the CFast cards. Doing so may cause failure, malfunction, injury, or a fire.
- After the first use of the product, do not insert/remove the CFast card to/from the CPU module more than 10,000 times. Exceeding the limit may cause malfunction.
- Do not touch the metal terminals on the back side of the SD memory card and CFast card. Doing so may cause malfunction or failure of the module.
- Before handling the CFast card, touch a conducting object such as a grounded metal to discharge the static electricity from the human body. Failure to discharge the static electricity may cause the CFast card to fail or malfunction.

[Precautions for using I/O modules (with safety functions)]

- Do not drop or apply strong shock to the module. Doing so may damage the module.
 - Check the I/O module (with safety functions) once a day, by turning on output signals and confirming that no error occurs.
-

[Operating Precautions]

CAUTION

- When changing data and operating status, and modifying program of the running programmable controller from an external device such as a personal computer connected to an intelligent function module, read relevant manuals carefully and ensure the safety before operation. Incorrect change or modification may cause system malfunction, damage to the machines, or accidents.
- Do not power off the programmable controller or reset the CPU module while the setting values in the buffer memory are being written to the flash ROM in the module. Doing so will make the data in the flash ROM and SD memory card undefined. The values need to be set in the buffer memory and written to the flash ROM and SD memory card again. Doing so can cause malfunction or failure of the module.

[Precautions for using positioning modules, Motion CPUs, Simple Motion modules, and Motion modules]

- Note that when the reference axis speed is specified for interpolation operation, the speed of the partner axis (2nd, 3rd, or 4th axis) may exceed the speed limit value.
- Do not go near the machine during test operations or during operations such as teaching. Doing so may lead to injuries.

[Precautions for using C Controller modules]

- A C Controller module requires preparation time from when the module is powered on or is reset until it is connectable for connecting to an engineering tool or FTP. Do not connect a C Controller module to an engineering tool or FTP during the preparation time.

A C Controller module is connectable at the timing when the BUS RUN LED of the C Controller module is turned on (RUN status) after setting the RESET/STOP/RUN switch to the RUN position.

[Computer Connection Precautions]

CAUTION

- When connecting a personal computer to a module having a USB interface, observe the following precautions as well as the instructions described in the manual for the personal computer used. Failure to do so may cause the module to fail.

(1) When the personal computer is AC-powered

When the personal computer has a 3-pin AC plug or an AC plug with a grounding wire, connect the plug to a grounding receptacle or ground the grounding wire. Ground the personal computer and the module with a ground resistance of 100 ohms or less.

When the personal computer has a 2-pin AC plug without a grounding wire, connect the computer to the module by following the procedure below. For power supplied to the personal computer and the module, using the same power source is recommended.

1. Unplug the personal computer from the AC receptacle.
2. Check that the personal computer is unplugged. Then, connect the personal computer to the module with a USB cable.
3. Plug the personal computer into the AC receptacle.

(2) When the personal computer is battery-powered

The personal computer can be connected to the module without taking specific measures.

For details, refer to the following.

Cautions When Using Mitsubishi Electric Controllers or GOTs Connected to a Personal Computer Via RS-232/USB Interface (FA-A-0298)

When the USB cable used is the GT09-C30USB-5P manufactured by Mitsubishi Electric, specific measures are not required to connect the AC-powered personal computer to the module. However, note that the signal ground (SG) is common for the module and its USB interface. Therefore, if an SG potential difference occurs between the module and the connected devices, it causes failures of the module and the connected devices.

[Disposal Precautions]

CAUTION

- When disposing of this product, treat it as industrial waste.
 - When disposing of batteries, separate them from other wastes according to the local regulations. For details on battery regulations in EU member states, refer to Page 292 Disposal precautions in this manual.
-

[Transportation Precautions]

CAUTION

- When transporting lithium batteries, follow the transportation regulations. For details on the regulated models, refer to Page 291 Transport guidelines in this manual.
- The halogens (such as fluorine, chlorine, bromine, and iodine), which are contained in a fumigant used for disinfection and pest control of wood packaging materials, may cause failure of the product. Prevent the entry of fumigant residues into the product or consider other methods (such as heat treatment) instead of fumigation. The disinfection and pest control measures must be applied to unprocessed raw wood.

[Precautions for using I/O modules (with safety functions)]

- For shipping, always use the original packaging.
-

[Precautions for Using Products]

CAUTION

[Precautions for using I/O modules (with safety functions)]

- Although MELCO has obtained the certification for Product's compliance to the international safety standards IEC 61508 and ISO 13849-1 from TUV Rheinland, this fact does not guarantee that Product will be free from any malfunction or failure.
 - With very small probability shown in PFDavg / PFH, the I/O module (with safety functions) has residual risk that input and output may remain on or off. When using this product, perform risk assessment on target equipment, and select appropriate SIL and PL, as well as reduce the risk.
 - This product complies with following requirements of international safety standards: SIL3 (IEC 61508: 2010), PL_e (EN ISO 13849-1: 2015).
-

CONDITIONS OF USE FOR THE PRODUCT

- (1) MELSEC programmable controller ("the PRODUCT") shall be used in conditions;
- i) where any problem, fault or failure occurring in the PRODUCT, if any, shall not lead to any major or serious accident; and
 - ii) where the backup and fail-safe function are systematically or automatically provided outside of the PRODUCT for the case of any problem, fault or failure occurring in the PRODUCT.
- (2) The PRODUCT has been designed and manufactured for the purpose of being used in general industries. MITSUBISHI ELECTRIC SHALL HAVE NO RESPONSIBILITY OR LIABILITY (INCLUDING, BUT NOT LIMITED TO ANY AND ALL RESPONSIBILITY OR LIABILITY BASED ON CONTRACT, WARRANTY, TORT, PRODUCT LIABILITY) FOR ANY INJURY OR DEATH TO PERSONS OR LOSS OR DAMAGE TO PROPERTY CAUSED BY THE PRODUCT THAT ARE OPERATED OR USED IN APPLICATION NOT INTENDED OR EXCLUDED BY INSTRUCTIONS, PRECAUTIONS, OR WARNING CONTAINED IN MITSUBISHI ELECTRIC USER'S, INSTRUCTION AND/OR SAFETY MANUALS, TECHNICAL BULLETINS AND GUIDELINES FOR the PRODUCT.
- ("Prohibited Application")
- Prohibited Applications include, but not limited to, the use of the PRODUCT in;
- Nuclear Power Plants and any other power plants operated by Power companies, and/or any other cases in which the public could be affected if any problem or fault occurs in the PRODUCT.
 - Railway companies or Public service purposes, and/or any other cases in which establishment of a special quality assurance system is required by the Purchaser or End User.
 - Aircraft or Aerospace, Medical applications, Train equipment, transport equipment such as Elevator and Escalator, Incineration and Fuel devices, Vehicles, Manned transportation, Equipment for Recreation and Amusement, and Safety devices, handling of Nuclear or Hazardous Materials or Chemicals, Mining and Drilling, and/or other applications where there is a significant risk of injury to the public or property.
- Notwithstanding the above restrictions, Mitsubishi Electric may in its sole discretion, authorize use of the PRODUCT in one or more of the Prohibited Applications, provided that the usage of the PRODUCT is limited only for the specific applications agreed to by Mitsubishi Electric and provided further that no special quality assurance or fail-safe, redundant or other safety features which exceed the general specifications of the PRODUCTS are required. For details, please contact the Mitsubishi Electric representative in your region.
- (3) Mitsubishi Electric shall have no responsibility or liability for any problems involving programmable controller trouble and system trouble caused by DoS attacks, unauthorized access, computer viruses, and other cyberattacks.

- For SIL2 Process CPUs

- (1) The Product has been certified by a third-party certification body as being in compliance with the IEC 61508 safety standards and meets the requirements of the IEC 61511 safety standards. However, this does not guarantee that the Product is free from malfunctions or failures. The user of this Product shall comply with any and all applicable safety standard, regulation or law and take appropriate safety measures for the system in which the Product is installed or used and shall take the second or third safety measures other than the Product. Mitsubishi Electric is not liable for damages that could have been prevented by compliance with any applicable safety standard, regulation or law.
- (2) Mitsubishi Electric prohibits the use of Products with or in any application involving, and Mitsubishi Electric shall not be liable for a default, a liability for defect warranty, a quality assurance, negligence or other tort and a product liability in these applications.
 - (a) power plants,
 - (b) trains, railway systems, airplanes, airline operations, other transportation systems,
 - (c) hospitals, medical care, dialysis and life support facilities or equipment,
 - (d) amusement equipments,
 - (e) incineration and fuel devices,
 - (f) handling of nuclear or hazardous materials or chemicals,
 - (g) mining and drilling,
 - (h) and other applications where the level of risk to human life, health or property are elevated.
- (3) Mitsubishi Electric shall have no responsibility or liability for any problems involving programmable controller trouble and system trouble caused by DoS attacks, unauthorized access, computer viruses, and other cyberattacks.

- For Safety CPUs

- (1) Although Mitsubishi Electric has obtained the certification for Product's compliance to the international safety standards IEC61508, ISO13849-1 from TUV Rheinland, this fact does not guarantee that Product will be free from any malfunction or failure. The user of this Product shall comply with any and all applicable safety standard, regulation or law and take appropriate safety measures for the system in which the Product is installed or used and shall take the second or third safety measures other than the Product. Mitsubishi Electric is not liable for damages that could have been prevented by compliance with any applicable safety standard, regulation or law.
- (2) Mitsubishi Electric prohibits the use of Products with or in any application involving, and Mitsubishi Electric shall not be liable for a default, a liability for defect warranty, a quality assurance, negligence or other tort and a product liability in these applications.
 - (a) power plants,
 - (b) trains, railway systems, airplanes, airline operations, other transportation systems,
 - (c) hospitals, medical care, dialysis and life support facilities or equipment,
 - (d) amusement equipments,
 - (e) incineration and fuel devices,
 - (f) handling of nuclear or hazardous materials or chemicals,
 - (g) mining and drilling,
 - (h) and other applications where the level of risk to human life, health or property are elevated.
- (3) Mitsubishi Electric shall have no responsibility or liability for any problems involving programmable controller trouble and system trouble caused by DoS attacks, unauthorized access, computer viruses, and other cyberattacks.

INTRODUCTION

Thank you for purchasing the Mitsubishi Electric MELSEC iQ-R series programmable controllers.

This manual describes the system configuration, specifications, installation, wiring, maintenance, and inspection of MELSEC iQ-R series programmable controllers.

Before using this product, please read this manual and the relevant manuals carefully and develop familiarity with the functions and performance of the MELSEC iQ-R series programmable controller to handle the product correctly.

When applying the program and circuit examples provided in this manual to an actual system, ensure the applicability and confirm that it will not cause system control problems.

Note that the menu names and operating procedures may differ depending on an operating system in use and its version.

When reading this manual, replace the names and procedures with the applicable ones as necessary.

Please make sure that the end users read this manual.

C Controller module

When using the C Controller module and reading this manual and relevant manuals, read "programmable controller CPU" as "C Controller module".

Refer to the following instead of the GX Works3 Operating Manual, MELSEC iQ-R CPU Module User's Manual (Startup), and MELSEC iQ-R CPU Module User's Manual (Application).

 CW Configurator Operating Manual

 MELSEC iQ-R C Controller Module User's Manual

Motion CPU

When using the Motion CPU and reading this manual and relevant manuals, read "programmable controller CPU" as "Motion CPU".

Refer to the following instead of the MELSEC iQ-R CPU Module User's Manual (Startup) and MELSEC iQ-R CPU Module User's Manual (Application).

 MELSEC iQ-R Motion Controller User's Manual

 MELSEC iQ-R Motion Controller Programming Manual (Common)

NCCPU

When using the NCCPU and reading this manual and relevant manuals, read "programmable controller CPU" as "NCCPU".

Refer to the following instead of the MELSEC iQ-R CPU Module User's Manual (Startup) and MELSEC iQ-R CPU Module User's Manual (Application).

 C80 Series Connection and Setup Manual

 C80 Series Instruction Manual

 C80 Series Maintenance Manual

Robot CPU

When using the robot CPU and reading this manual and relevant manuals, read "programmable controller CPU" as "robot CPU".

Refer to the following instead of the MELSEC iQ-R CPU Module User's Manual (Startup) and MELSEC iQ-R CPU Module User's Manual (Application).

 SAFETY MANUAL

 Standard Specifications Manual for the controller used

 CR800 Series Controller INSTRUCTION MANUAL Controller setup, basic operation, and maintenance

 CR800 Series Controller INSTRUCTION MANUAL Detailed explanations of functions and operations

 CR800 Series Controller INSTRUCTION MANUAL Troubleshooting

 CR800 series controller ADDITIONAL AXIS FUNCTION INSTRUCTION MANUAL

 CR800 series controller Tracking Function Instruction Manual

 CR800-D series controller GOT Direct Connection Extended Function Instruction Manual

 CR800-R series controller iQ Platform Supporting Extended Function Instruction Manual

 CR750/CR751 series controller, CR800 series controller Ethernet Function Instruction Manual

MELSECWinCPU module

When using the MELSECWinCPU module and reading this manual and relevant manuals, read "programmable controller CPU" as "MELSECWinCPU module".

Refer to the following instead of the GX Works3 Operating Manual, MELSEC iQ-R CPU Module User's Manual (Startup), and MELSEC iQ-R CPU Module User's Manual (Application).

 CW Configurator Operating Manual

 MELSEC iQ-R MELSECWinCPU Module User's Manual

MELSEC iQ-R series manuals

The manuals are categorized into the following.

Read the Module Configuration Manual before configuring the system because the common information on all modules are included.

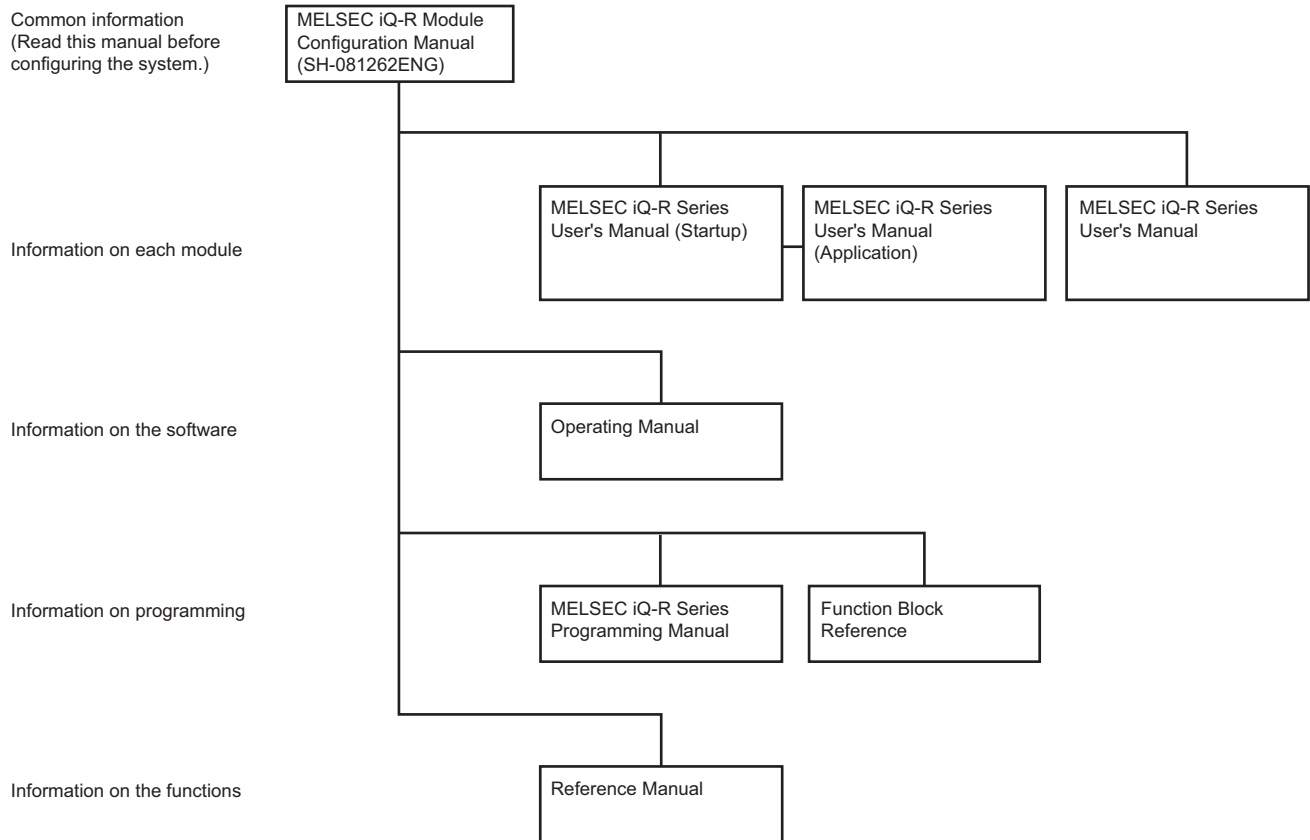

No.	Manual	Description
(1)	Module Configuration Manual	Module Configuration Manual describes common information on the hardware configuration of all modules, overview of each system configuration, and specifications of the power supply module, base unit, SD memory card, and battery.
(2)	User's Manual	User's Manual for modules such as the CPU modules and intelligent function modules consists of Startup and Application. Startup describes specifications, function lists, procedures before operation, and operation examples of each module. Application describes details on I/O signals/buffer memory addresses/functions, parameter settings, error codes, special relay areas, and special register areas of each module. For some other modules, their User's Manuals consist of a single volume instead of Startup and Application.
(3)	Operating Manual	Operating Manual describes operation methods of the tool.
(4)	Programming Manual	The Programming Manual consists of manuals such as Program Design which describes the program languages, CPU Module Instructions, Standard Functions/Function Blocks and Module Dedicated Instructions which describe the instructions and functions, and Process Control Function Blocks/Instructions which describes the function blocks for process control.
(5)	Function Block Reference	Function Block Reference describes module FBs of each model.
(6)	Reference Manual	Reference Manual describes common functions of modules (such as the online module change and the inter-module synchronization function) or specifications of communication protocols, and how to use them.

CONTENTS

SAFETY PRECAUTIONS	1
CONDITIONS OF USE FOR THE PRODUCT	29
INTRODUCTION	31
TERMS	37
GENERIC TERMS AND ABBREVIATIONS	39
CHAPTER 1 SYSTEM CONFIGURATION	41
1.1 Overall Configuration	41
Single CPU system	45
Multiple CPU system	45
Redundant system	46
System using the Safety CPU	62
System using the SIL2 Process CPU	65
1.2 Lists of Configuration Devices	74
MELSEC iQ-R series	74
MELSEC-Q series	83
1.3 System Configuration Specifications	86
Modules having restrictions on the number of mountable modules	90
Base unit combination	95
Combinations of a base unit and a power supply module	95
Combinations of CPU modules in a multiple CPU system	96
1.4 Applicable Software	97
1.5 Precautions for System Configuration	97
Precautions when using the extended temperature range base unit	97
Consideration for internal current consumption	98
Precautions for multiple CPU system configuration	99
Precautions for redundant system with redundant extension base unit	104
Precautions for C Controller system configuration	106
Precautions for MELSECWinCPU module system configuration	108
Precautions when using a recorder module or camera recorder module	109
Precautions when using a C intelligent function module	109
Precautions when using an MES interface module (RD81MES96N)	110
Precautions when using an OPC UA server module	110
Precautions when using a high speed data logger module	111
Precautions when using a high speed data communication module	111
CHAPTER 2 ASSIGNMENT FOR MODULES	112
2.1 Slot Numbers on a Base Unit	113
2.2 I/O Numbers of Modules	117
2.3 CPU Numbers	126
2.4 Control CPU	128
CHAPTER 3 PART NAMES	129
3.1 Power Supply Module	129
3.2 Base Unit	131
Main base unit	131
Extension base unit	132
Redundant extension base unit	133

RQ extension base unit (for MELSEC-Q series modules)	134
3.3 SD Memory Card	135
CHAPTER 4 SPECIFICATIONS	136
4.1 General Specifications	136
4.2 Performance Specifications of Power Supply Module	137
4.3 Performance Specifications of Base Unit	141
Main base unit	141
Extension base unit	143
RQ extension base unit (for MELSEC-Q series modules)	145
4.4 Performance Specifications of SD Memory Card	146
4.5 Performance Specifications of CFast Card	148
4.6 Performance Specifications of Battery	149
Application	149
Battery life	149
Precautions	155
CHAPTER 5 INSTALLATION AND WIRING	156
5.1 Installation Environment	156
5.2 Installation Position	157
5.3 Installing Base Unit to Control Panel	160
Installation method	160
5.4 Mounting Base Unit on the DIN Rail	162
Mounting the base unit on the DIN rail	162
5.5 Connection Method for the Extension Base Unit	170
When a redundant system with redundant extension base unit is configured	170
When MELSEC-Q series modules are used	171
5.6 Connection/Disconnection of Extension Cable	176
MELSEC iQ-R series extension cable	176
MELSEC-Q series extension cable	177
Handling precautions	178
5.7 Wiring	179
Wiring to the power supply module	179
Wiring to a screw terminal block	183
Wiring to a spring clamp terminal block (Q6TE-18SN)	185
Wiring to a spring clamp terminal block (R60TCTRT2TT2-TS, R60TCRT4-TS)	186
Wiring to a spring clamp terminal block (lever type)	188
Wiring a connector	190
Grounding	193
5.8 Mounting/Removing a Module or Terminal Block	194
Mounting/removing a module on/from a main base unit or extension base unit	194
Mounting/removing a module on/from a RQ extension base unit	199
Installing/removing a terminal block	201
Handling precautions	204
CHAPTER 6 MAINTENANCE AND INSPECTION	205
6.1 Daily Inspection	205
6.2 Periodic Inspection	206
Battery replacement procedure	207
Replacement procedure of redundant power supply modules	209

APPENDICES	210
Appendix 1 Checking Production Information and Firmware Version	210
Checking methods	210
Appendix 2 Firmware Update Function	212
Update using an engineering tool	212
Update using an SD memory card	228
Appendix 3 Pair Version	244
Checking methods	244
Appendix 4 Troubleshooting by Symptom	245
When the POWER LED of the power supply module turns off, or the ERR contact turns off (opens)	245
When the specific extension base unit cannot be recognized	245
When the specific Q series extension base unit cannot be recognized	246
When an error occurs in a redundant extension base unit	246
Appendix 5 Differences Between MELSEC iQ-R Series and MELSEC-Q Series	247
Appendix 6 How to Use MELSEC-Q Series Modules	248
Window change between GX Works2 and GX Works3	248
Setting procedure	252
Refresh processing time	254
Precautions	256
Appendix 7 EMC and Low Voltage Directives	262
Measures to comply with the EMC Directive	262
Measures to comply with the Low Voltage Directive	278
Appendix 8 Machinery Directive	280
Measures to comply with the Machinery Directive	280
Appendix 9 General Safety Requirements	282
System design circuit examples	282
Fail-safe measures for programmable controller failure	287
Appendix 10 Calculating Heating Value of Programmable Controller	288
Calculation formula for the average power consumption	288
Calculation examples for the average power consumption	290
Appendix 11 Precautions for Battery Transportation	291
Regulated models	291
Transport guidelines	291
Appendix 12 Handling of Batteries and Devices with Built-In Batteries in EU Member States	292
Disposal precautions	292
Exportation precautions	292
Appendix 13 Type Approval Certificates for Ship Classifications	294
Appendix 14 External Dimensions	295
Power supply module	295
Base unit	297

INDEX	306
REVISIONS	308
WARRANTY	311
INFORMATION AND SERVICES	316
TRADEMARKS	316

TERMS

Unless otherwise specified, this manual uses the following terms.

Term	Description
Control CPU	A CPU module that controls connected I/O modules and intelligent function modules. In a multiple CPU system, a control CPU is set to each connected module.
Control system	A system that controls a redundant system and performs network communications in a redundant system
Dedicated instruction	An instruction that simplifies programming for using functions of intelligent function modules
Engineering tool	A tool used for setting up programmable controllers, programming, debugging, and maintenance
Intelligent function module	A module that has functions other than input and output, such as an A/D converter module and D/A converter module
Multiple CPU system	A system where 2 to 4 CPU modules control I/O modules or intelligent function modules assigned to
New control system	A system that has switched to control system from standby system after system switching
Process CPU (process mode)	A Process CPU operating in process mode. Process control function blocks and the online module change function can be used.
Process CPU (redundant mode)	A Process CPU operating in redundant mode. A redundant system is configured with this CPU module. Process control function blocks and the online module change function can be used even in this mode.
Redundant function module	A module that configures a redundant system and is used with a Process CPU (redundant mode) or a SIL2 Process CPU. The redundant function module model name is R6RFM.
Redundant power supply system	A system that has two power supply modules on a base unit. Even if one power supply module has failed, operation can be continued with the other power supply module.
Redundant system	A system consisting of two systems that have the same configuration (CPU module, power supply module, network module, and other modules). Even after an error occurs in one of the two system, the other system takes over the control of the entire system. (Page 46 Redundant system)
Redundant system with redundant extension base unit	A redundant system that is configured using extension base unit(s)
Relay station	A station that includes two or more network modules. Data are passed through this station to stations on other networks.
Safety CPU	A module that performs both standard control and safety control and is used with a safety function module. The Safety CPU models include the R08SFPCPU, R16SFPCPU, R32SFPCPU, and R120SFPCPU.
Safety function module	A module that performs safety control and must be used with a Safety CPU. This module can only be used with the Safety CPU. The safety function module model name is R6SFM.
SIL2 function module	A module that performs safety control and must be used with a SIL2 Process CPU. This module can only be used with the SIL2 Process CPU. The SIL2 function module model name is R6PSFM.
SIL2 mode	An operation mode of the I/O module and the intelligent function module to perform safety input and output at the SIL2 level. For details on the SIL2 mode, refer to the following. Manuals for the I/O module or the intelligent function module used
SIL2 Process CPU	A module that performs both standard control and safety control and is used with a SIL2 function module. This module is also used with a redundant function module and configures a redundant system. The SIL2 Process CPU models include the R08PSFPCPU, R16PSFPCPU, R32PSFPCPU, and R120PSFPCPU.
Single CPU system	A system where a single CPU module controls I/O modules and intelligent function modules
Slim type main base unit	A MELSEC iQ-R series slim type main base unit
Slim type power supply module	A MELSEC iQ-R series slim type power supply module
Standby system	A backup system in a redundant system
System A	A system specified as a system A to distinguish between two systems connected with a tracking cable. When the two systems are simultaneously started up, the system A operates as a control system. The system A is not changed to the system B even after system switching.
System B	A system specified as a system B to distinguish between two systems connected with a tracking cable. When the two systems are simultaneously started up, the system B operates as a standby system. The system B is not changed to the system A even after system switching.
System switching	A function which switches the systems between the control system and the standby system to continue operation of the redundant system when a failure or an error occurs in the control system
Tracking cable	An optical fiber cable used to connect two redundant function modules in a redundant system

The following terms are used to explain systems using the SIL2 Process CPU and the Safety CPU.

Term	Description
Pair version	Version information to determine the pairs of the SIL2 Process CPU and SIL2 function module and the pairs of the Safety CPU and Safety function module
Safety communications	Communication service that performs send/receive processing in the safety layer of the safety communication protocol
Safety control	Machine control by safety programs and safety data communications. When an error occurs, the machine in operation is securely stopped.
Safety device	A device that can be used in safety programs
Safety program	A program that performs safety control
Standard communications	Communications other than safety communications, such as cyclic transmission and transient transmission of CC-Link IE Field Network
Standard control	Machine control by standard programs and standard data communications. Programmable controllers other than the safety programmable controller perform only standard control. (This term is used to distinguish from safety control.)
Standard device	A device (X, Y, M, D, or others) in a CPU module. (Safety devices are excluded.) This device can be used only in standard programs. (This term is used to distinguish from a safety device.)
Standard program	A program that performs sequence control (Safety programs are excluded.) (This term is used to distinguish from a safety program.)

GENERIC TERMS AND ABBREVIATIONS

Unless otherwise specified, this manual uses the following generic terms and abbreviations.

Generic term/abbreviation	Description
Base unit	A main base unit, an extension base unit, an RQ extension base unit
C Controller module	A MELSEC iQ-R series C Controller module
CC-Link IE	Includes the following: <ul style="list-style-type: none"> • CC-Link IE TSN (📖 MELSEC iQ-R CC-Link IE TSN User's Manual (Application), 📖 MELSEC iQ-R CC-Link IE TSN Plus Master/Local Module User's Manual) • CC-Link IE Controller Network (📖 MELSEC iQ-R CC-Link IE Controller Network User's Manual (Application)) • CC-Link IE Field Network (📖 MELSEC iQ-R CC-Link IE Field Network User's Manual (Application))
CC-Link IE Controller Network-equipped module	An RJ71GP21-SX CC-Link IE Controller Network module, an RJ71GP21S-SX CC-Link IE Controller Network module, and the following modules when the CC-Link IE Controller Network function is used: <ul style="list-style-type: none"> • RJ71EN71 • RnENCPU
CC-Link IE Field Network-equipped master/local module	An RJ71GF11-T2 CC-Link IE Field Network master/local module and the following modules when the CC-Link IE Field Network function is used: <ul style="list-style-type: none"> • RJ71EN71 • RnENCPU
CC-Link IE TSN master/local module	RJ71GN11-T2, RJ71GN11-SX, RJ71GN11-EIP (CC-Link IE TSN part)
Control module	A MELSEC iQ-R laser displacement sensor control module
Device station	A station other than a master station: a local station, a remote I/O station, a remote device station, and an intelligent device station
Ethernet interface module with built-in CC-Link IE	RJ71EN71
Extended temperature range base unit	A base unit that is compatible with an operating ambient temperature of 0°C to 60°C
Extension base unit	A MELSEC iQ-R series extension base unit
Extension cable	A MELSEC iQ-R series extension cable
I/O module	An input module, an output module, an I/O combined module, and an interrupt module
Main base unit	A MELSEC iQ-R series main base unit
MELSECWinCPU module	A MELSEC iQ-R series MELSECWinCPU module
Motion CPU	A MELSEC iQ-R series Motion controller
Motion module	RD78G4, RD78G8, RD78G16, RD78G32, RD78G64, RD78GHV, RD78GHW
NCCPU	R16NCCPU
Network module	Includes the following: <ul style="list-style-type: none"> • Ethernet interface module • CC-Link IE TSN master/local module • CC-Link IE Controller Network module • CC-Link IE Field Network master/local module • MELSECNET/H network module • MELSECNET/10 network module • RnENCPU (network part)
Power supply module	A MELSEC iQ-R series power supply module
Process CPU	R08PCPU, R16PCPU, R32PCPU, R120PCPU
Programmable controller CPU	R00CPU, R01CPU, R02CPU, R04CPU, R04ENCPU, R08CPU, R08ENCPU, R16CPU, R16ENCPU, R32CPU, R32ENCPU, R120CPU, R120ENCPU
Q5□B	A MELSEC-Q series extension base unit (type requiring no power supply module)
Q6□B	A MELSEC-Q series extension base unit (type requiring a power supply module)
Redundant extension base unit	An extension base unit which is essential for configuring a redundant system with redundant extension base unit
Redundant power supply base unit	A base unit used for a redundant configuration of power supplies. This unit is used together with redundant power supply modules, to build a redundant power supply system.
Redundant power supply module	A power supply module used for a redundant configuration of power supplies. This module is used together with a redundant power supply base unit, to build a redundant power supply system.
Remote head module	An RJ72GF15-T2 CC-Link IE Field Network remote head module
RJ71GN11-EIP (CC-Link IE TSN part)	An RJ71GN11-EIP when it performs communications on CC-Link IE TSN

Generic term/abbreviation	Description
RJ71GN11-EIP (EtherNet/IP part)	An RJ71GN11-EIP when it performs communications on EtherNet/IP
RnCPU	R00CPU, R01CPU, R02CPU, R04CPU, R08CPU, R16CPU, R32CPU, R120CPU
RnENCPU	R04ENCPU, R08ENCPU, R16ENCPU, R32ENCPU, R120ENCPU
RnENCPU (CPU part)	A module on the left-hand side of the RnENCPU (📖 MELSEC iQ-R Ethernet/CC-Link IE User's Manual (Startup))
RnENCPU (network part)	A module on the right-hand side of the RnENCPU (📖 MELSEC iQ-R Ethernet/CC-Link IE User's Manual (Startup))
Robot CPU	R16RTCPU
RQ extension base unit	A MELSEC iQ-R series RQ extension base unit

The following generic terms and abbreviations are used to explain systems using the SIL2 Process CPU and the Safety CPU.

Generic term and abbreviation	Description
Safety programmable controller	A MELSEC iQ-R series module that performs safety control: a Safety CPU, a safety function module, a CC-Link IE Field Network remote I/O module (with safety functions)
Standard CPU	A MELSEC iQ-R series CPU module that performs standard control (This term is used to distinguish such CPU modules from the CPU modules that perform safety control.)
Standard programmable controller	A MELSEC iQ-R series module that performs standard control (This term is used to distinguish such programmable controllers from the safety programmable controllers.)

1 SYSTEM CONFIGURATION

This chapter describes the MELSEC iQ-R series system configuration.

1.1 Overall Configuration

The MELSEC iQ-R series programmable controller system is configured by mounting modules on a base unit. A power supply module is mounted on the power supply slot located on the left end of a main base unit, and a CPU module is mounted on the CPU slot located on the right side of the power supply slot. Modules other than the power supply module are mounted on the slots located on the right side of the CPU slot.

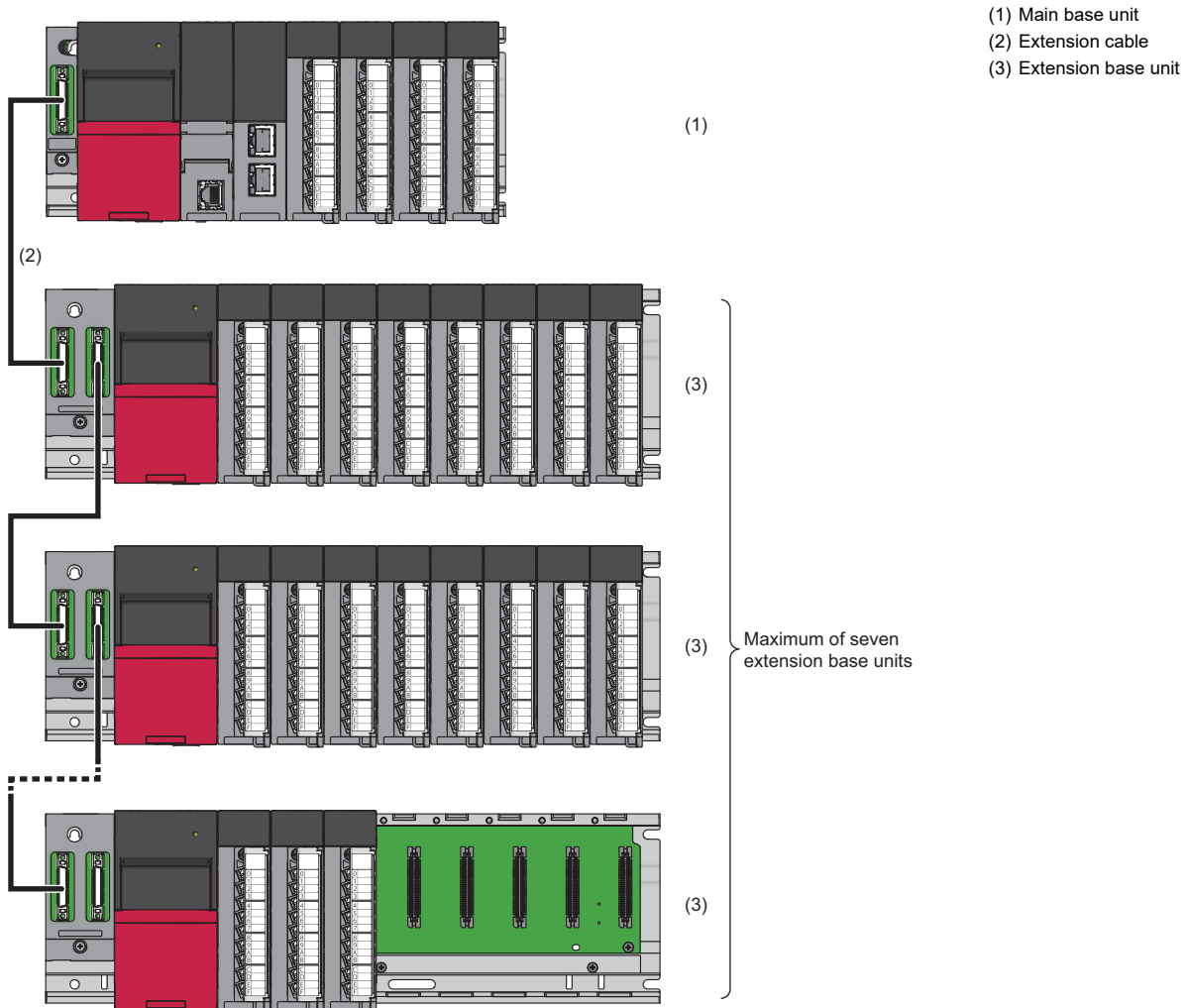

MELSEC-Q series modules and base units can be used by connecting the RQ extension base unit in the MELSEC iQ-R series system. (☞ Page 170 Connection Method for the Extension Base Unit)
MELSEC-Q series power supply modules, I/O modules, and intelligent function modules can be mounted on the RQ extension base unit. (☞ Page 134 RQ extension base unit (for MELSEC-Q series modules))
Using the RQ extension base unit enables the use of the existing MELSEC-Q series system as shown below.

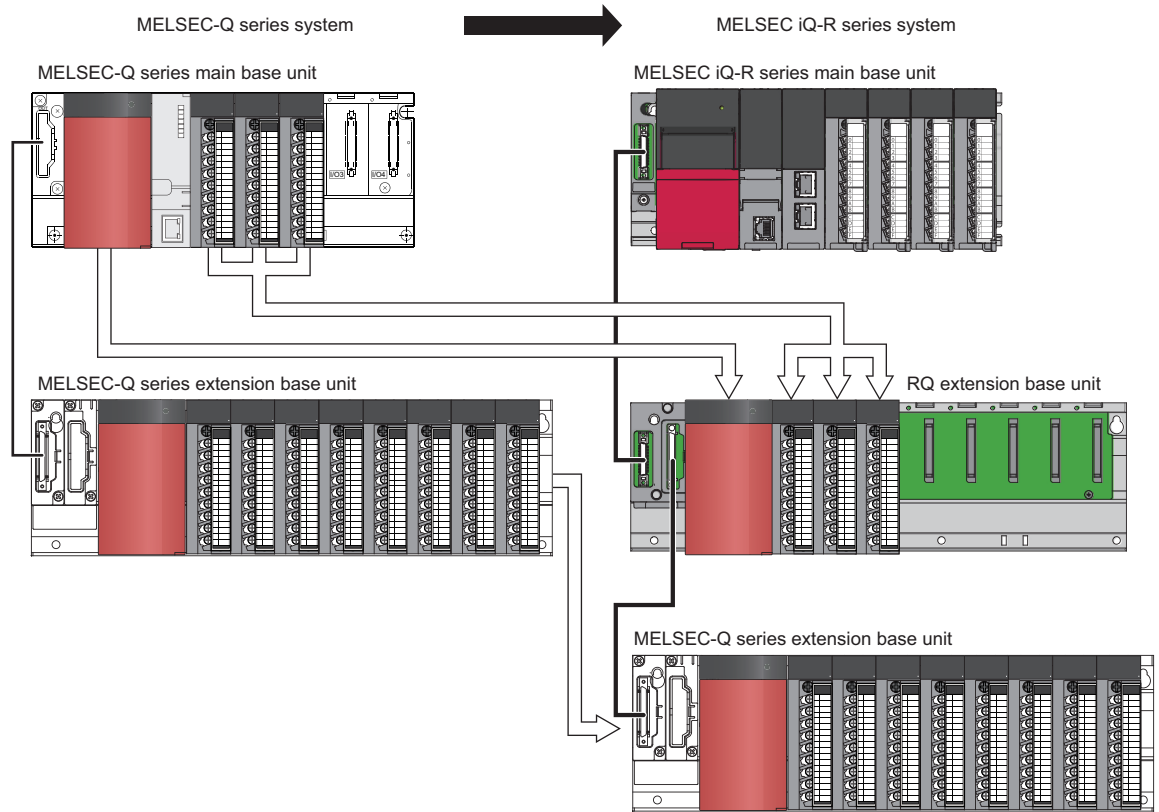

Connecting systems over various networks such as Ethernet and CC-Link IE enables seamless data communications across various levels, from the production control of all automation down to a device such as a sensor.

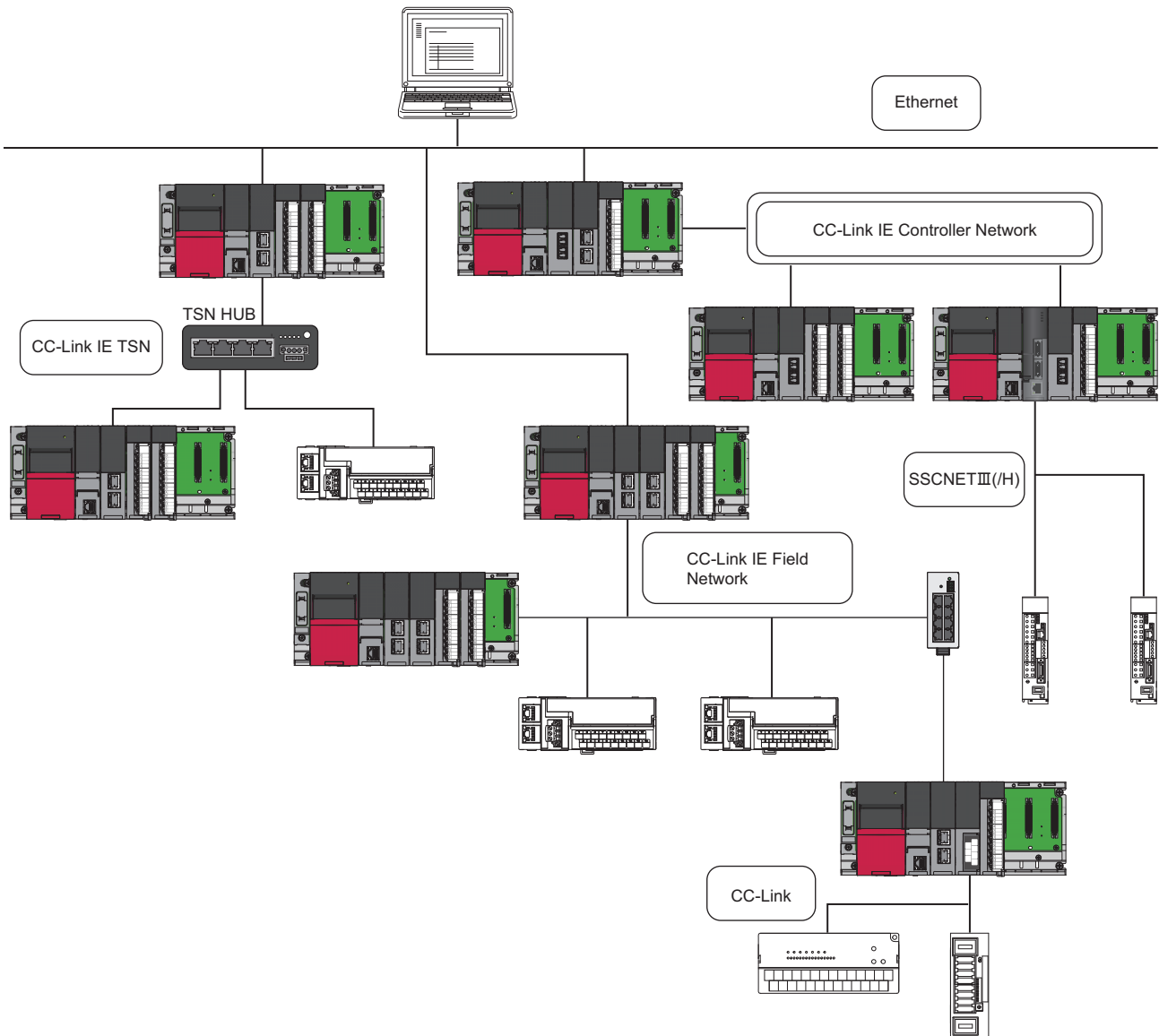

- Without being aware of layers and boundaries of the networks, access to the production control system, programmable controllers, and other devices is possible in a seamless and identical manner. Device monitoring and data collection are easy to perform from anywhere.
- CC-Link IE is the network with a large capacity and a high speed of 1Gbps. The 1Gbps broad bandwidth which is divided into two parts, one for control communications and the other for information communications, ensures the time reliability of control communications and achieves a real-time data collection, which is not allowed via TCP/IP.
- CC-Link is a globally standardized open field network. Flexible support for a multi-vendor environment allows a rich variety of more than 1000 partner products to be connected to the MELSEC iQ-R series.
- SSCNET III/(H) is a synchronous motion network that supports optical network and offers high speed and high reliability.

Ex.

Other series network can be connected by setting relay stations with multiple modules of difference network.

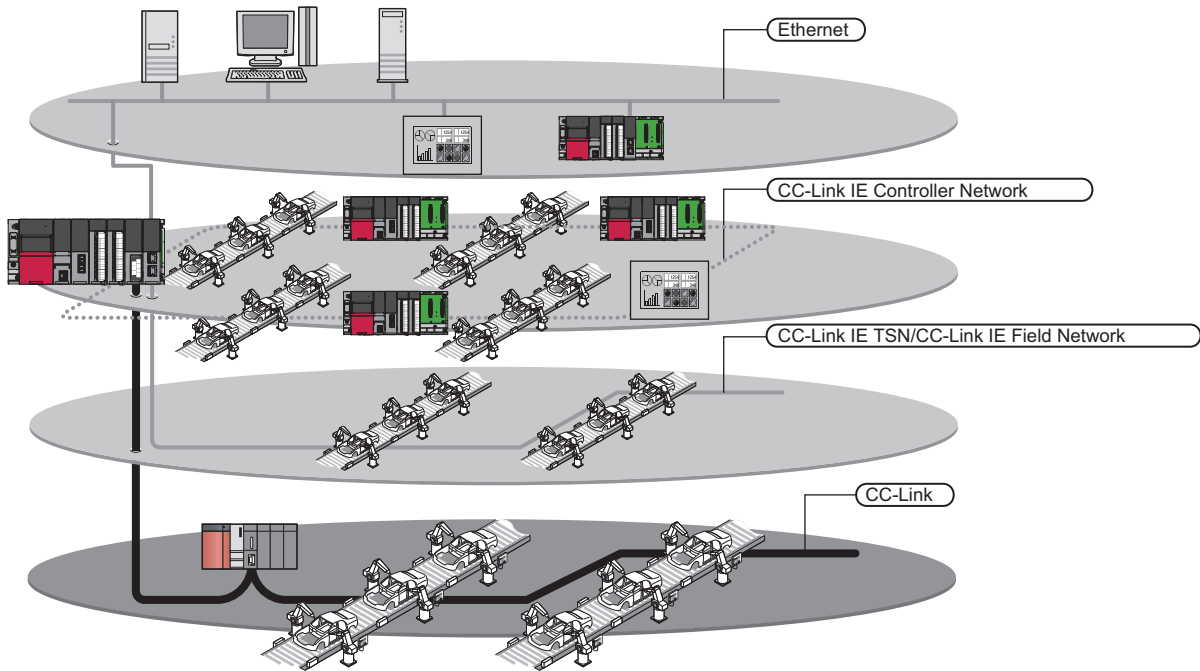

For the network modules that can be used in the MELSEC iQ-R series system, refer to the following.

☞ Page 74 Lists of Configuration Devices

Single CPU system

This system controls I/O modules and intelligent function modules with a single CPU module mounted on a main base unit.

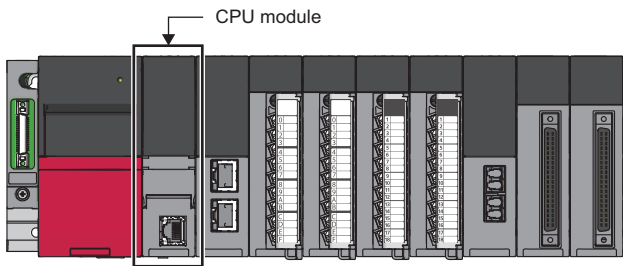

Multiple CPU system

This system requires multiple CPU modules, and each CPU module controls I/O modules and intelligent function modules.

([Page 128 Control CPU](#))

Configure a multiple CPU system in the following cases:

- To execute the high-accuracy motion control by using a Motion CPU in a system
- To execute the high-accuracy NC control by using the NCCPU in a system
- To execute the high-accuracy machining and assembly by using the robot CPU in a system
- To shorten the scan time of the entire system by distributing the control of I/O modules and intelligent function modules with multiple CPU modules

The CPU module can only be mounted on the main base unit, and the maximum number of mountable CPU modules is four.

([Page 96 Combinations of CPU modules in a multiple CPU system](#), [Page 126 CPU Numbers](#))

For details on the multiple CPU system function, refer to the following.

[MELSEC iQ-R CPU Module User's Manual \(Application\)](#)

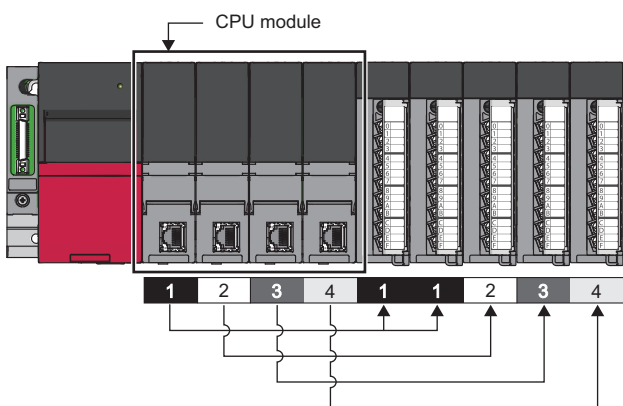

Redundant system

A redundant system consists of two systems that have the same configuration (CPU module, power supply module, network module, and other modules). Even if an error occurs in one system, the other system takes over the control of the entire system.

I/O modules and intelligent function modules used in a redundant system are mounted to the intelligent device station (remote head module) on CC-Link IE Field Network or an extension base unit in a redundant system with redundant extension base unit.

A redundant configuration of power supply modules is available with redundant power supply base units and redundant power supply modules. (Redundant power supply system)

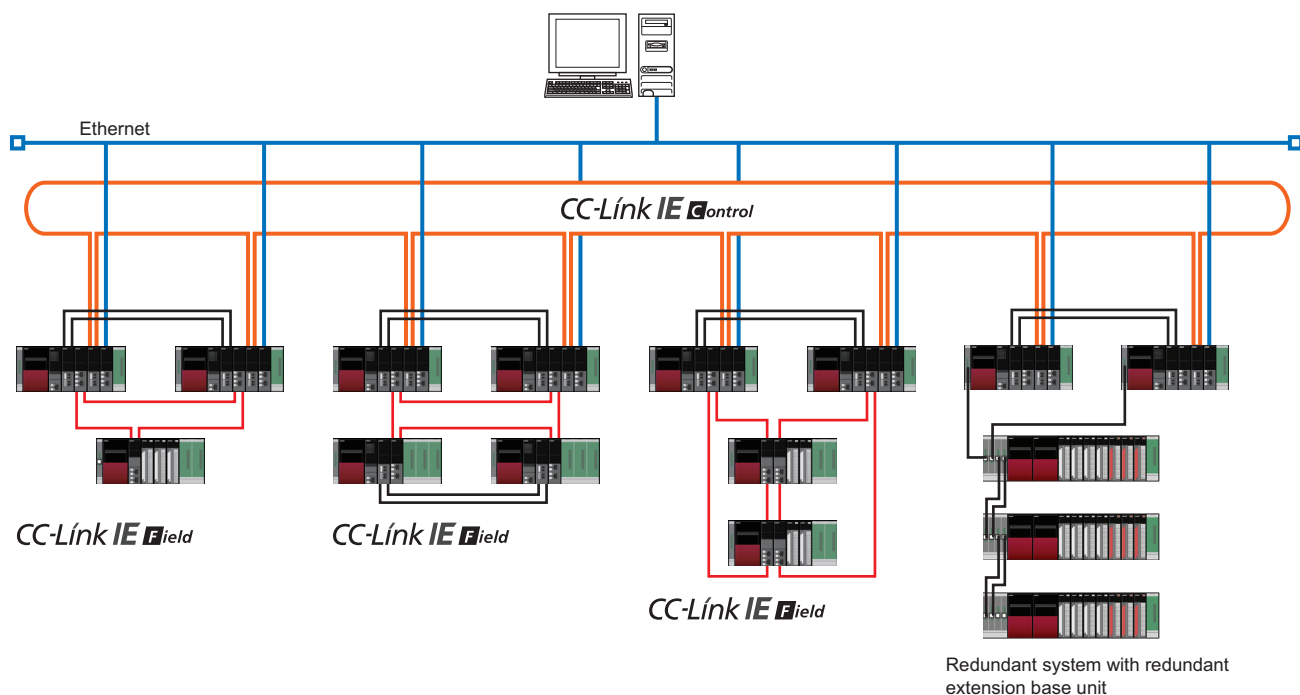

The redundant system is categorized into the following types.

- ☞ Page 47 Redundant configuration of basic systems
- ☞ Page 50 Redundant configuration of power supply modules
- ☞ Page 51 Redundant system for Ethernet
- ☞ Page 51 Redundant system for CC-Link IE Controller Network
- ☞ Page 52 Redundant system for CC-Link IE Field Network
- ☞ Page 54 When CC-Link is used in a redundant system
- ☞ Page 55 Redundant system for MELSECNET/H network module
- ☞ Page 55 Redundant system for PROFIBUS-DP network
- ☞ Page 56 Redundant system for serial communication

Redundant configuration of basic systems

A basic system (CPU module, power supply module, network module, and other modules on a main base unit) can be redundant using a redundant function module and operating the Process CPU used in redundant mode.

To configure a redundant system, configure two basic systems that have the same configuration including a redundant function module, and connect the redundant function modules in those two systems with tracking cables. Connecting the redundant function modules with two tracking cables also makes the cables to be redundant.

Mount modules of the same model on the same slot of each main base unit. The redundant function module can be mounted on any slot of the main base unit. (It does not need to be mounted on the right side of the CPU module.)

In a redundant system, the CPU module of one system executes programs and controls the entire redundant system. The other system will be in the standby state and does not perform control. The system that performs control is called "control system" and the system in the standby state is called "standby system".

Data link is performed between redundant function modules connected with tracking cables. If an error occurs in the control system, the system is switched to the standby system and the standby system continues the operation.

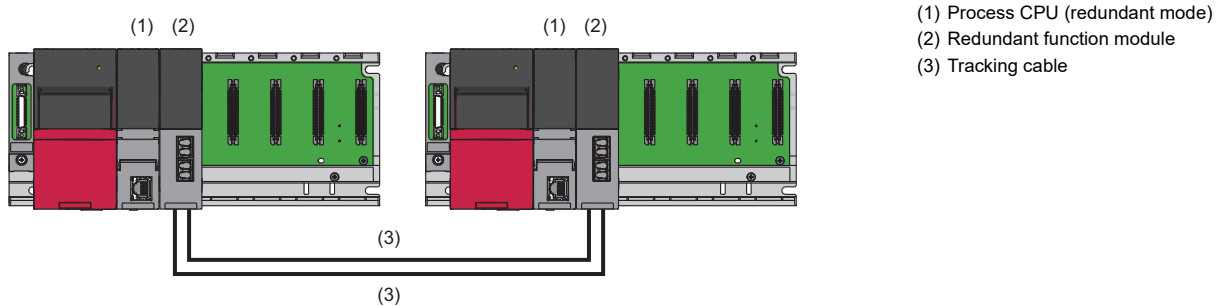

For details, refer to "WHEN USING THE PROCESS CPU (REDUNDANT MODE)" in the following.

MELSEC iQ-R CPU Module User's Manual (Application)

Redundant system with redundant extension base unit

A redundant system to which extension base units are connected (redundant system with redundant extension base unit) is available.

To configure a redundant system with redundant extension base unit, connect a redundant extension base unit to the extension level 1. ( Page 104 Precautions for redundant system with redundant extension base unit)

Comparing with the redundant configuration that uses the CC-Link IE Field Network remote head module, the CPU module can communicate data with input and output modules faster with this configuration.

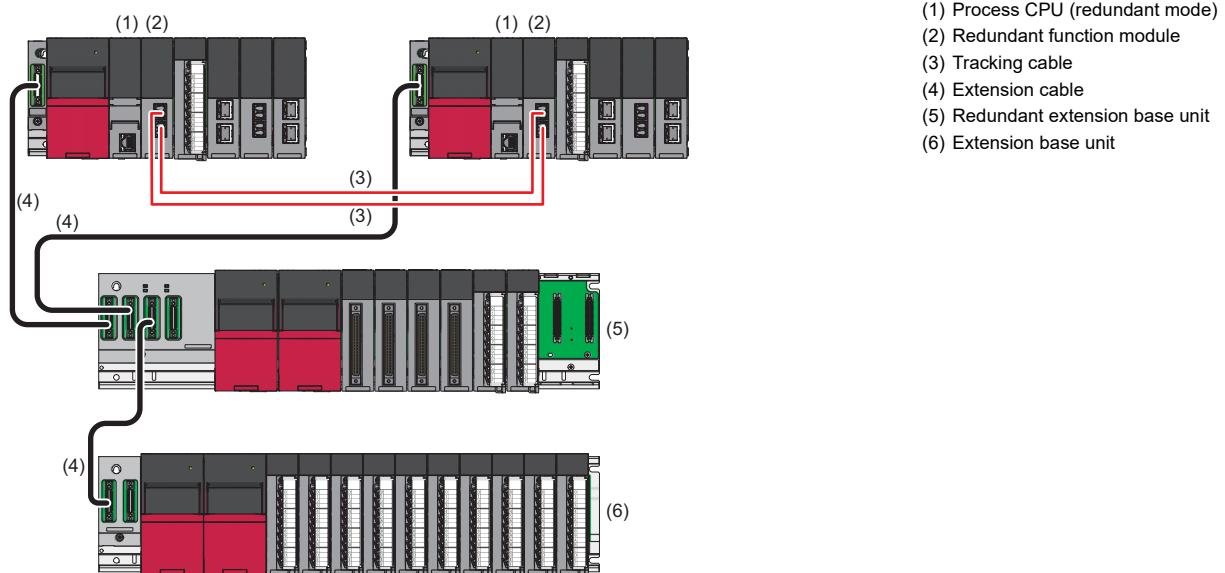

Point

The redundant system with redundant extension base unit can be configured in combination with the redundant system configuration that uses the CC-Link IE Field Network remote head module. ( Page 46 Redundant system)

■ Redundant configuration of extension cables

With the redundant configuration of extension cables, control of the redundant system can be maintained by switching the systems even if an extension cable in data communications fails.

To achieve extension cable redundancy, use the redundant extension base units in the extension level 2 and later levels.

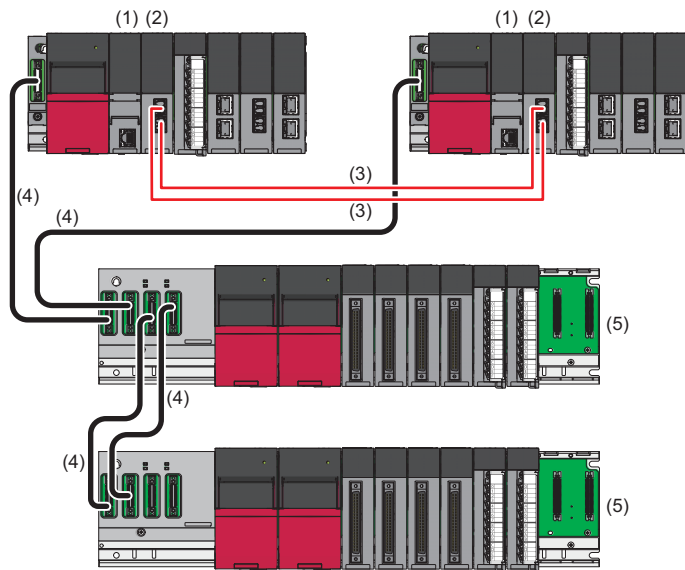

- (1) Process CPU (redundant mode)
- (2) Redundant function module
- (3) Tracking cable
- (4) Extension cable
- (5) Redundant extension base unit

Point

Extension cables are preferably redundant at all extension levels because if an error occurs in an extension cable not being redundant, a stop error occurs in the CPU module of both systems and the control of the entire system cannot be maintained.

Redundant configuration of power supply modules

A redundant power supply module can be redundant by mounting two redundant power supply modules on a redundant power supply base unit. (Redundant power supply system)

Even if the power supply module fails or an error occurs in the power supply source connected to the power supply module in one system, system operation will be continued with the power supply module in the other system.

The power supply system error can be cleared or the failed power supply module can be replaced online. The power supply module can also be replaced online as preventive maintenance. (➡ Page 209 Replacement procedure of redundant power supply modules)

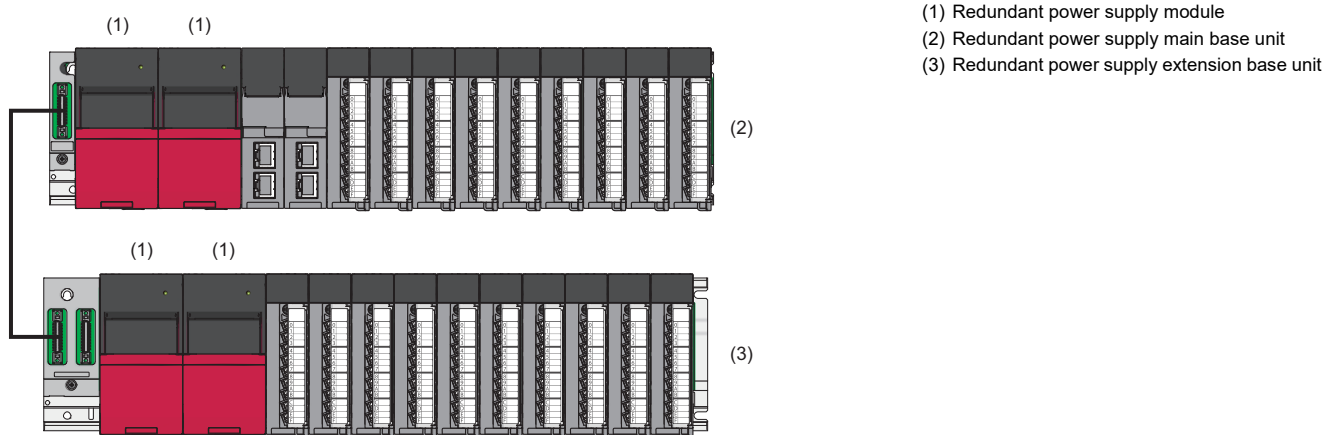

Point

A redundant power supply system can be configured with CPU modules other than Process CPUs (redundant mode). For the modules compatible with redundant power supply base units and redundant power supply modules, check "Lists of configuration devices". (➡ Page 74 Lists of Configuration Devices)

Redundant system for Ethernet

By mounting an Ethernet interface module on each of the base units of the control system and standby system, the new control system can continue communications if an error occurs in the control system.

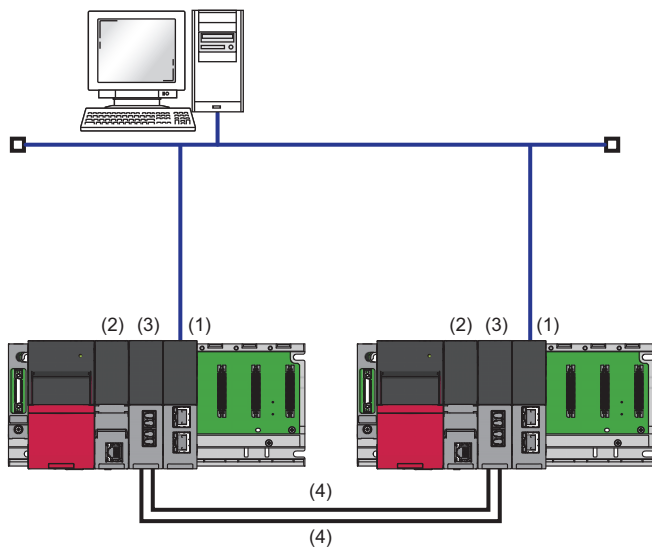

- (1) Ethernet interface module
- (2) Process CPU (redundant mode)
- (3) Redundant function module
- (4) Tracking cable

■ Redundant group setting

The redundant group setting is used to ensure that when the Ethernet network is duplicated in a redundant system, system switching is not executed for an error that occurs in one Ethernet network.

There are two types of redundant group setting: redundant module group setting and port group setting.

For details, refer to "Redundant System Function" in the following.

📖 MELSEC iQ-R Ethernet User's Manual (Application)

Redundant system for CC-Link IE Controller Network

By mounting a CC-Link IE Controller Network module on each of the base units of the control system and standby system, the new control system can continue data link if an error occurs in the control system.

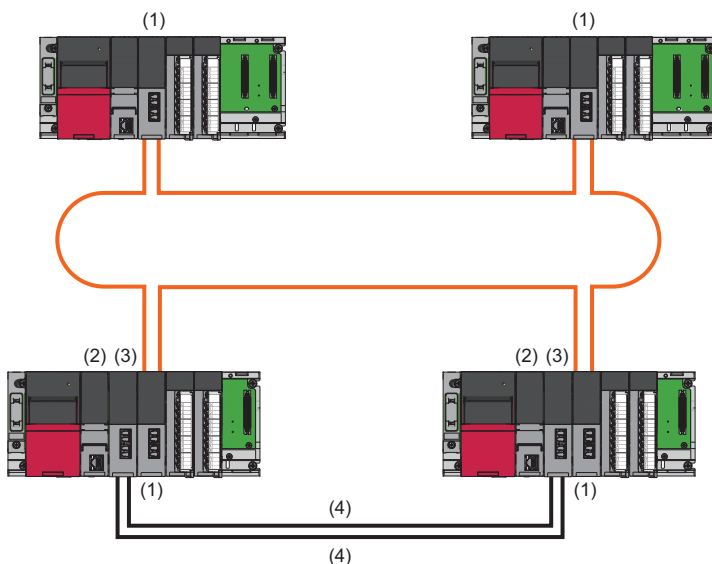

- (1) CC-Link IE Controller Network module
- (2) Process CPU (redundant mode)
- (3) Redundant function module
- (4) Tracking cable

For details, refer to "Redundant System Function" in the following.

📖 MELSEC iQ-R CC-Link IE Controller Network User's Manual (Application)

Redundant system for CC-Link IE Field Network

With a redundant configuration of CC-Link IE Field Network master/local modules or remote head modules, the new control system can continue data link if an error occurs in the control system.

The following table lists the redundant system configurations for CC-Link IE Field Network.

System configuration	Overview
Redundant specified station	Redundant master station A redundant configuration of the master station is available. When the redundant master station is used as the own station, the station can be connected to the following. • Device station • Redundant device station
	Redundant device station A redundant configuration of the device station is available. When the redundant device station is used as the own station, the station can be connected to the following. • Master station or redundant master station • Device station • Redundant device station
Redundant configuration of entire network	Redundant line A redundant configuration of the entire network including the master station, device station, and transmission path is available. The redundant line is configured in combination with the redundant master station and redundant device station with the remote head module. When a communication error occurs in the master station or device station, the control is continued by the system switching of the whole network instead of the faulty station. For the redundant line, the time required for system switching is shorter than the redundant master station or redundant device station.

There are no restrictions on network topologies for redundant systems. However, the ring topology is recommended to configure a redundant system because the loopback function avoids system switching when a cable disconnection or a faulty station is generated in a system other than the redundant system.

■ Redundant master station

Mount a CC-Link IE Field Network master/local module on each of the base units of the control system and standby system. If an error occurs in the master station of the control system, the submaster station of the standby system performs control.

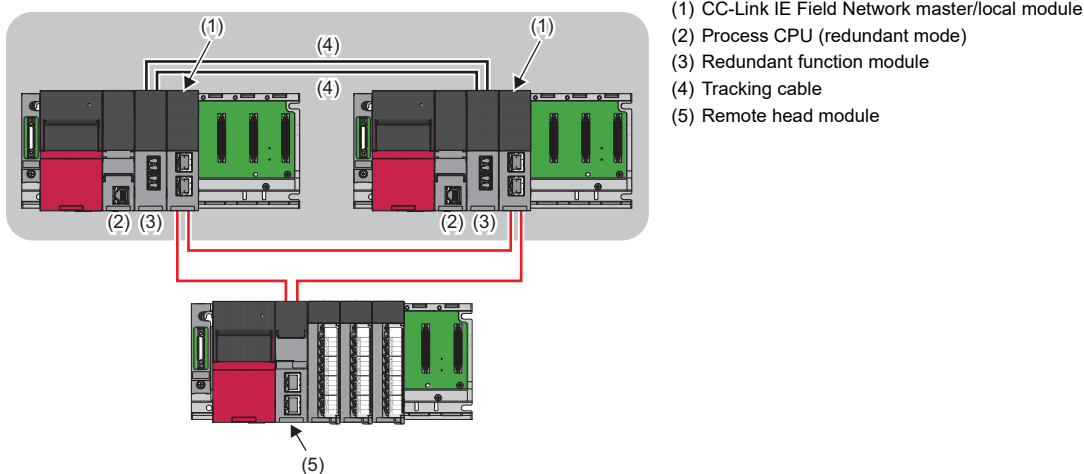

For details, refer to "Redundant System Function" in the following.

📖 MELSEC iQ-R CC-Link IE Field Network User's Manual (Application)

■Redundant device station

For the redundant device station, two types of redundant configurations, redundant local station and redundant remote head module, are provided.

- Redundant local station

Mount a CC-Link IE Field Network master/local module on each of the base units of the control system and standby system. If an error occurs in the local station of the control system, the local station of the standby system performs control.

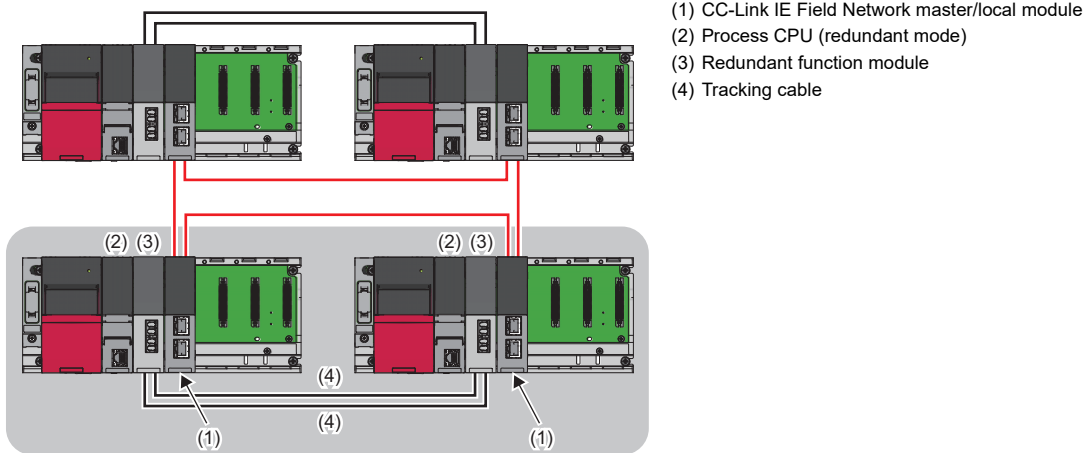

For details, refer to "Redundant System Function" in the following.

📖 MELSEC iQ-R CC-Link IE Field Network User's Manual (Application)

- Redundant configuration of remote head modules

Mount a remote head module to the CPU slot and slot No.0 of the base unit. If an error occurs in the remote head module of the control system, the remote head module of the standby system performs control.

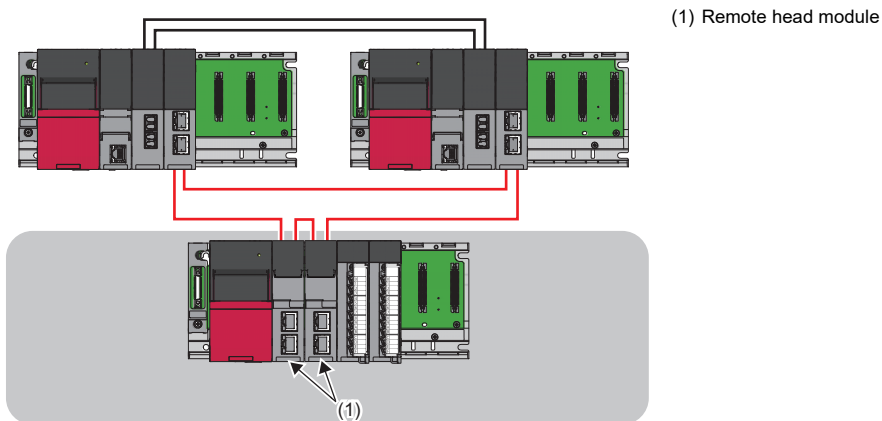

For details, refer to "Redundant Function" in the following.

📖 MELSEC iQ-R CC-Link IE Field Network Remote Head Module User's Manual (Application)

■Redundant line

A redundant configuration of network lines is available.

Mount a CC-Link IE Field Network master/local module on each of the base units of the control system and standby system in the master station where a redundant configuration has been configured. By mounting two remote head modules on the base unit of a device station, make a redundant configuration of the remote head modules. Connect the master station to the remote head modules of the control system and do the same for the standby system. With a redundant configuration of network lines, control is performed on a network of the standby system if an error occurs on the network of the control system.

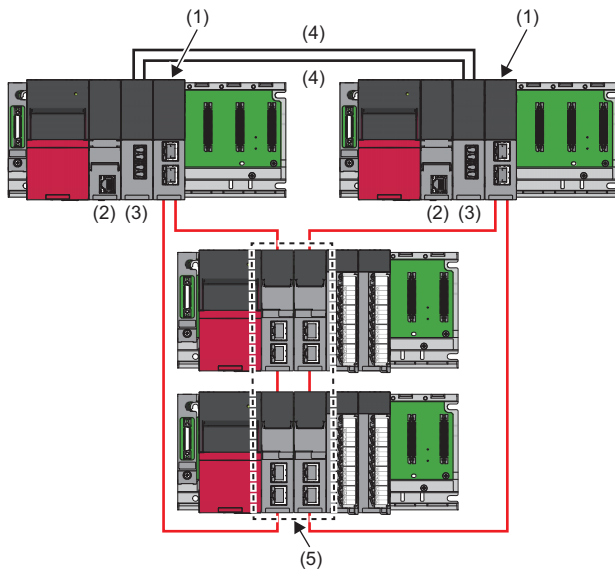

- (1) CC-Link IE Field Network master/local module
- (2) Process CPU (redundant mode)
- (3) Redundant function module
- (4) Tracking cable
- (5) Remote head module

Only the remote head modules used in the redundant system can be used for the device station.

For details, refer to "Redundant System Function" in the following.

📖 MELSEC iQ-R CC-Link IE Field Network User's Manual (Application)

When CC-Link is used in a redundant system

CC-Link system master/local modules can be used in a redundant system.

With the standby master function, system switching due to a stop error of a CPU module can be supported.

For details, refer to "How to Use Standby Master Function in Redundant System" in the following.

📖 MELSEC iQ-R CC-Link System Master/Local Module User's Manual (Application)

Redundant system for MELSECNET/H network module

The MELSECNET/H network module supports the PLC to PLC network which is for data communications between the control station and normal stations. (Only for the RJ71LP21-25)

In a redundant system, using a MELSECNET/H network module in both the control system and the standby system can continue the data link in the new control system if an error occurs in the current control system.

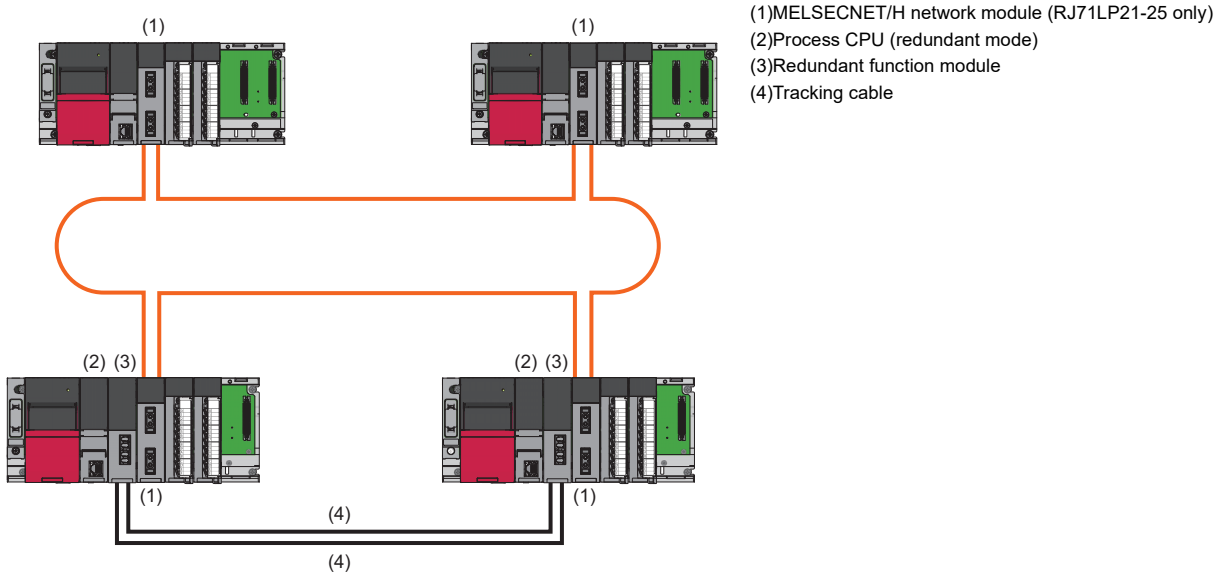

For details, refer to the following.

MELSEC iQ-R MELSECNET/H Network Module User's Manual (Application)

Redundant system for PROFIBUS-DP network

With a redundant configuration of the RJ71PB91V, the new control system can continue data communications if an error occurs in the control system.

■ System switching due to an error in the master station of the control system

Mount the RJ71PB91V on each base unit of the control system and standby system.

If an error occurs in the master station of the control system, the master station of the standby system performs control.

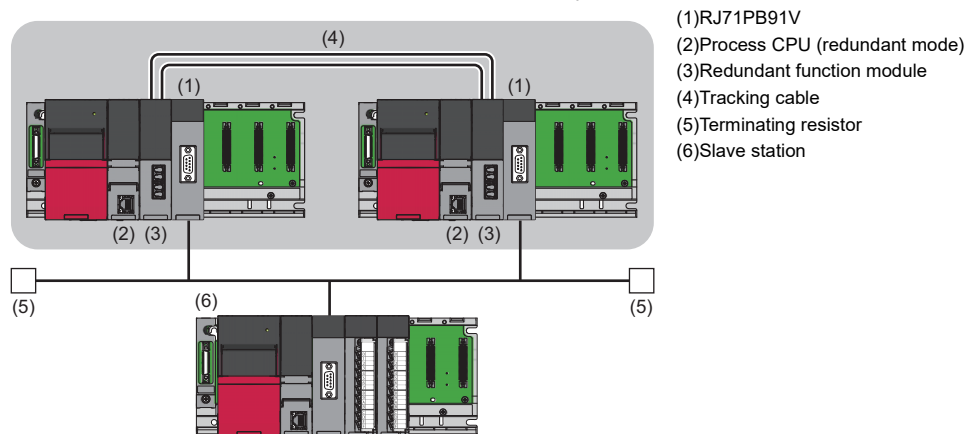

For details, refer to "Redundant System Function" in the following.

MELSEC iQ-R PROFIBUS-DP Module User's Manual (Application)

Redundant system for serial communication

By mounting a serial communication module on each of the base units of the control system and standby system, the new control system can continue communications if an error occurs in the control system.

The following table lists the communication protocols that can be used in a redundant system.

Communication	Communication protocol
MODBUS	<ul style="list-style-type: none"> • Master station (control system and standby system): Communication protocol • Slave station: MODBUS slave (RTU) or MODBUS slave (ASCII)

Communication protocols other than the predefined protocol and MODBUS slave (RTU/ASCII) cannot be used for communication.

For details, refer to "Using MODBUS in a Redundant System" in the following:

📖 MELSEC iQ-R Serial Communication Module User's Manual (Application)

The following table lists the redundant system configurations for serial communication.

System configuration	Overview	
Redundant specified station	Redundant master station (single line)	A redundant configuration of the master station is available.
	Redundant master station (redundant line)	
	Redundant slave station (redundant line)	A redundant configuration of the slave station is available.

■Redundant master station (single line)

Connect the master station of the control system and that of the standby system with a tracking cable.

If an error occurs in the master station of the control system, the master station of the standby system performs control and continues communications with a slave station.

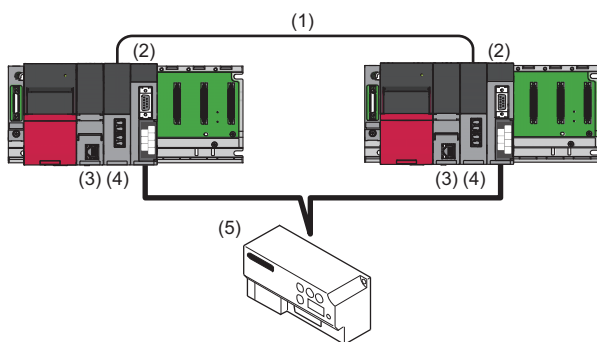

- (1) Tracking cable
- (2) Serial communication module
- (3) Process CPU (redundant mode)
- (4) Redundant function module
- (5) Slave station

■Redundant master station (redundant line)

Connect the master station of the control system and that of the standby system with a tracking cable.

Slave stations must be set for each master station.

If an error occurs in the master station of the control system, the master station of the standby system performs control and continues communications with slave stations.

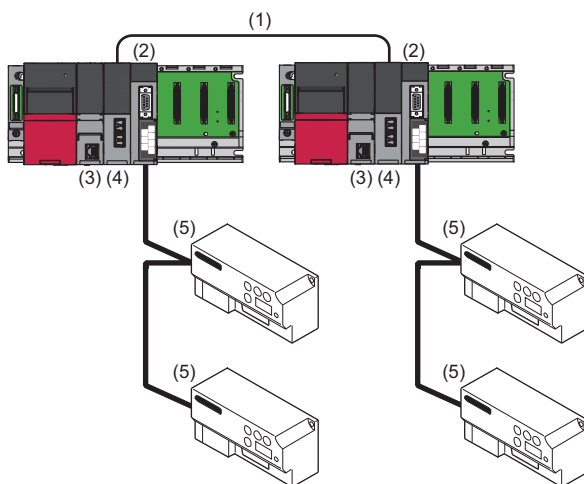

- (1) Tracking cable
- (2) Serial communication module
- (3) Process CPU (redundant mode)
- (4) Redundant function module
- (5) Slave station

■ Redundant slave station (redundant line)

Connect the slave station of the control system and that of the standby system with a tracking cable.

A line with the master station is required for each slave station.

If an error occurs in the slave station of the control system, the slave station of the standby system performs control and continues communications with the master station.

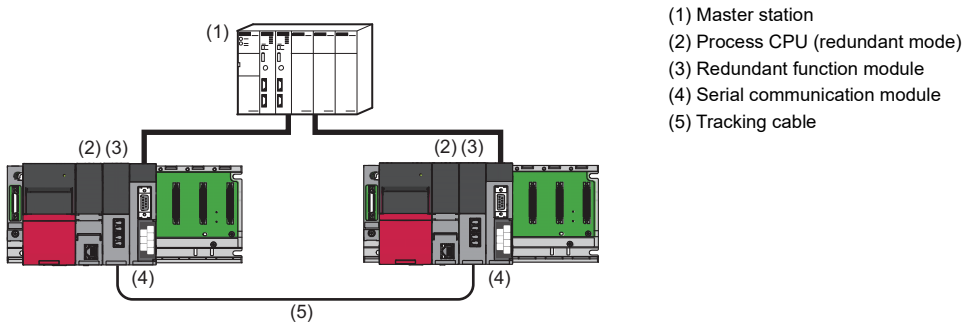

Settings specific to redundant systems

To configure a redundant system, select an operation mode and a model for the redundant system with the engineering tool. The following describes the modules for which users need to select an operation mode and a model for the redundant system.

■CPU module

When using the Process CPU in redundant mode, select "Redundant" for the operation mode.

Window

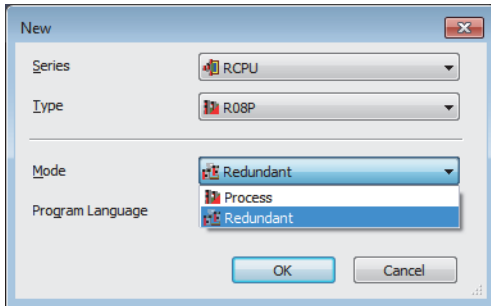

■CC-Link IE Controller Network

When placing a module on the "Module Configuration" window or adding a module on the "Navigation window" in the engineering tool, select "RJ71GP21-SX(R)" or "RJ71GP21S-SX(R)" for the model.

Window

RJ71GP21-SX	CC IE Control
RJ71GP21-SX(R)	CC IE Control(Redundant system)
RJ71GP21S-SX	CC IE Control (with external power supply function)
RJ71GP21S-SX(R)	CC IE Control (with external power supply function (Redundant system))

Point

RJ71GP21(S)-SX(R) is the model name on the engineering tool for using the RJ71GP21(S)-SX in a redundant system.

(R) of the model name is the abbreviation for Redundant.

The following describes model names to be selected using the following redundant system configuration for CC-Link IE Controller Network as an example.

Configuration example	Description
	<p>Select "RJ71GP21-SX" or "RJ71GP21S-SX" for the CC-Link IE Controller Network module mounted on the base unit for which a redundant configuration has not been made.</p> <p>Select "RJ71GP21-SX(R)" or "RJ71GP21S-SX(R)" for the CC-Link IE Controller Network module mounted on the base unit where the Process CPU (redundant mode) and the redundant function module have been mounted on and for which a redundant system has been configured.</p>

■CC-Link IE Field Network

When placing a module on the "Module Configuration" window or adding a module from the "Navigation window", select a proper model with the engineering tool depending on the application.

Configuration	CC-Link IE Field Network master/local module	Remote head module
Redundant master station	RJ71GF11-T2(MR)	RJ72GF15-T2
Redundant device station	RJ71GF11-T2(SR)	RJ72GF15-T2(SR)
Redundant line	RJ71GF11-T2(LR)	RJ72GF15-T2(LR)

Select a model name for the remote head module at project creation.

Window

- Project creation

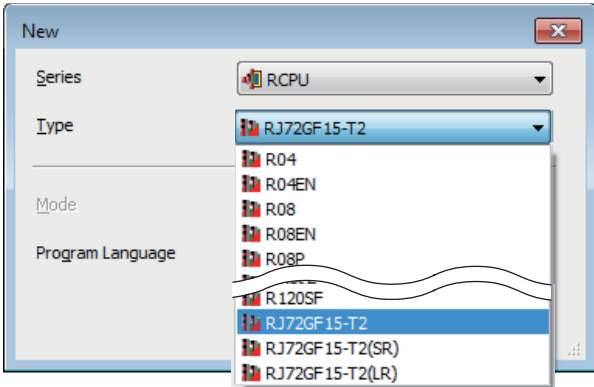

- "Element Selection" window of "Module Configuration" (CC-Link IE Field Network master/local module)

	RJ71GF11-T2	CC IE Field
	RJ71GF11-T2(LR)	CC IE Field(Redundant line system)
	RJ71GF11-T2(MR)	CC IE Field(Redundant master stations)
	RJ71GF11-T2(SR)	CC IE Field(Redundant slave stations)

- "Element Selection" window of "Module Configuration" (Remote head module)

Head Module	
	RJ72GF15-T2 CC IE Field
	RJ72GF15-T2(LR) CC IE Field(Redundant line)
	RJ72GF15-T2(SR) CC IE Field(Redundant slave stations)

Point

RJ71GF11-T2(LR), RJ71GF11-T2(MR), and RJ71GF11-T2(SR) are model names on the engineering tool for using the RJ71GF11-T2 in a redundant system. (Equivalent model names have been prepared for remote head modules.)

(LR), (MR), and (SR) of the model names are abbreviations as follows.

- LR: Line Redundant
- MR: Master Redundant
- SR: Slave Redundant

The following describes model names to be selected using the following redundant system configuration for CC-Link IE Field Network as an example.

- Redundant master station

Configuration example	Description
	<p>Select "RJ71GF11-T2(MR)" because a redundant configuration of the CC-Link IE Field Network master/local modules in the master station has been made.</p> <p>Select "RJ72GF15-T2" because the remote head module in the device station is not in the redundant system configuration.</p>

• Redundant device stations

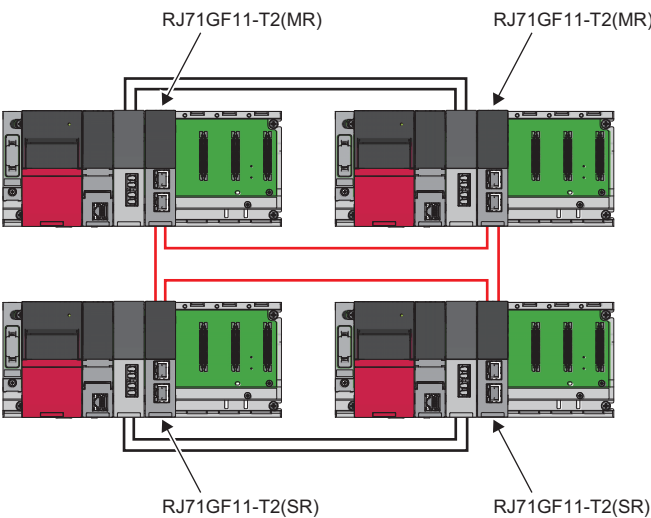
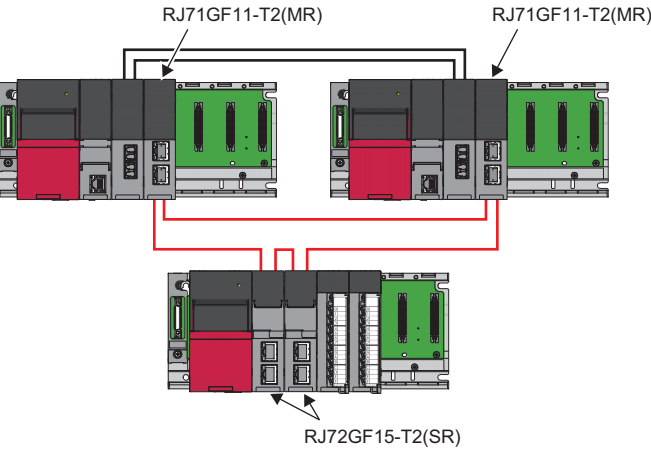
Configuration example	Description
<p>Redundant local station</p> 	<p>Select "RJ71GF11-T2(MR)" because a redundant configuration of the CC-Link IE Field Network master/local modules in the master station has been made.</p> <p>Select "RJ71GF11-T2(SR)" because a redundant configuration of the CC-Link IE Field Network master/local modules in the device stations has been made.</p>
<p>Redundant remote head modules</p> 	<p>Select "RJ71GF11-T2(MR)" because a redundant configuration of the CC-Link IE Field Network master/local modules in the master station has been made.</p> <p>Select "RJ72GF15-T2(SR)" because a redundant configuration of the remote head modules in the device station is made.</p>

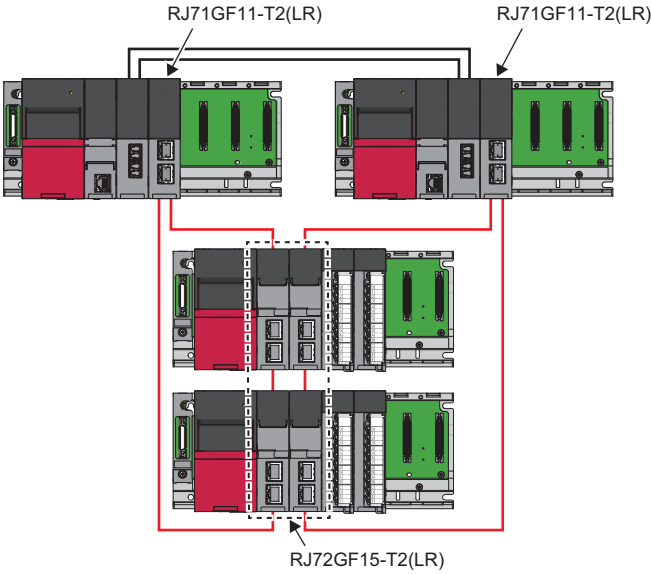

• Redundant line

Configuration example	Description
	<p>Select "RJ71GF11-T2(LR)" and "RJ72GF15-T2(LR)" for each of the CC-Link IE Field Network master/local modules of the master station and the remote head module of the device station because a redundant line configuration for these modules has been made.</p>

■ MELSECNET/H network

When placing a module on the "Module Configuration" window or adding a module on the "Navigation window" in the engineering tool, select "RJ71LP21-25(R)" for the model.

Window

 RJ71LP21-25	MELSECNET/H(Optical cable Duplex loop)
 RJ71LP21-25(R)	MELSECNET/H(Optical cable Duplex loop)(Redundant system)

Point

RJ71LP21-25(R) is the model name on the engineering tool for using the RJ71LP21-25 in a redundant system.

(R) of the model name is the abbreviation for Redundant.

The following describes model names to be selected using the following redundant system configuration for MELSECNET/H network as an example.

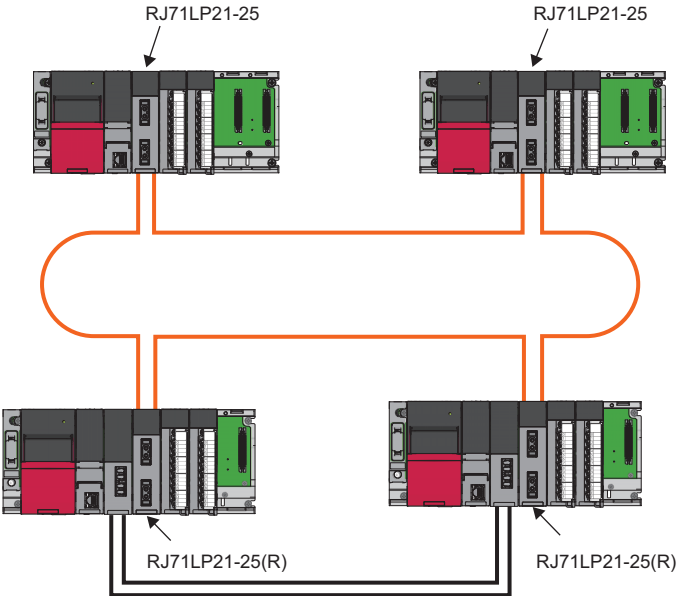
Configuration example	Description
	<p>Select "RJ71LP21-25" for the MELSECNET/H network module mounted on the base unit for which a redundant configuration has not been made.</p> <p>Select "RJ71LP21-25(R)" for the MELSECNET/H network module mounted on the base unit where the Process CPU (redundant mode) and the redundant function module have been mounted on and for which a redundant system has been configured.</p>

System using the Safety CPU

Systems using the Safety CPU obtained the highest safety approvals (ISO 13849-1:2015 Category 4 and PLe, IEC 62061:2012 SIL3, IEC 61508:2010 SIL3) that programmable controllers can obtain.

Programs for safety control and for standard control can be executed simultaneously by one Safety CPU module.

System using the network modules

Systems using the network modules perform both the safety communications and standard communications on one network.

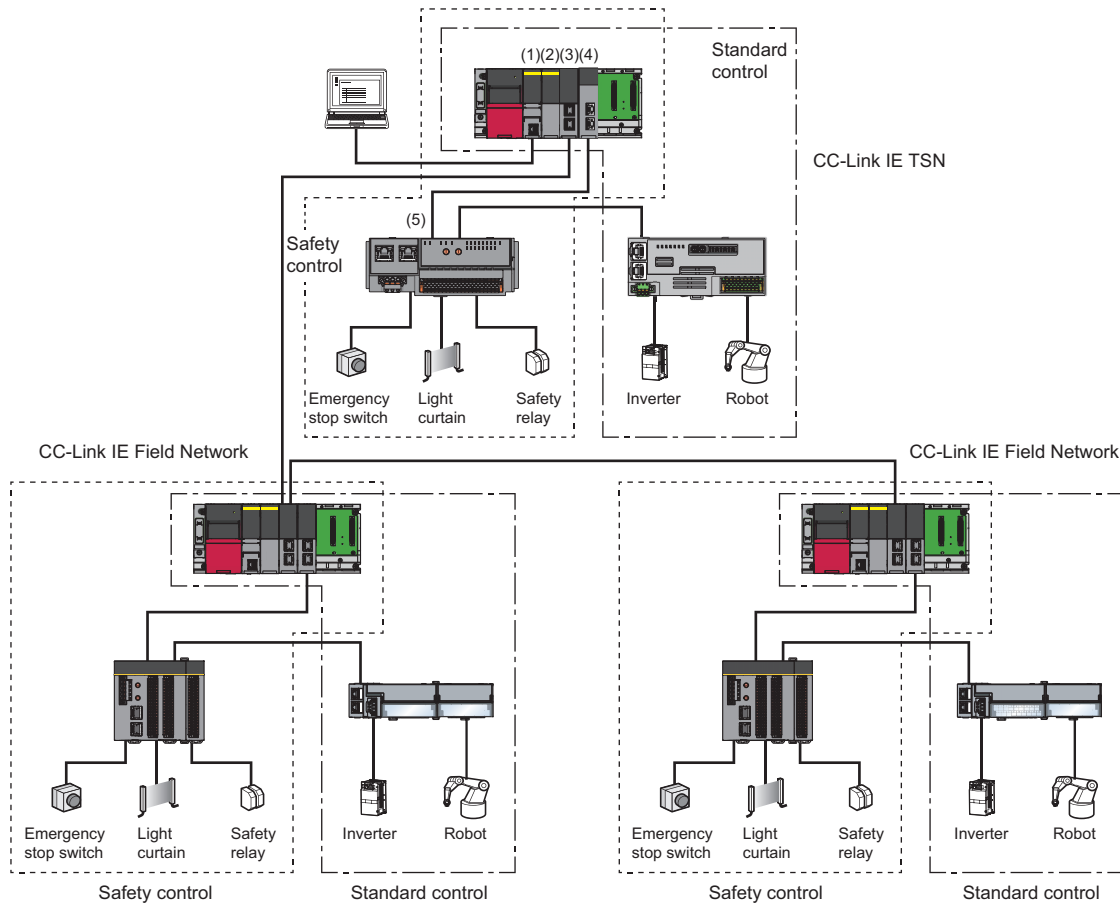

- (1) Safety CPU
- (2) Safety function module
- (3) CC-Link IE Field Network master/local module
- (4) CC-Link IE TSN master/local module (RJ71GN11-T2)
- (5) Safety remote I/O module

For the mounting position of the safety function module, refer to the following.

📖 Page 64 Mounting position of the safety function module

For details on the differences between the Safety CPU and standard CPU and functions of the Safety CPU, refer to the following.

📖 MELSEC iQ-R CPU Module User's Manual (Application)

Point

The Safety CPU and the safety function module must be of the same pair version. Check the pair version with the rating plate on the side of the module, special register, or buffer memory (Safety CPU: SD206, safety function module: Un\G60). (📖 Page 210 Rating plate, Page 244 Pair Version)

Proximity I/O system

The safety I/O refresh processing can be performed for a system that does not use a network module by using the I/O module with safety functions.

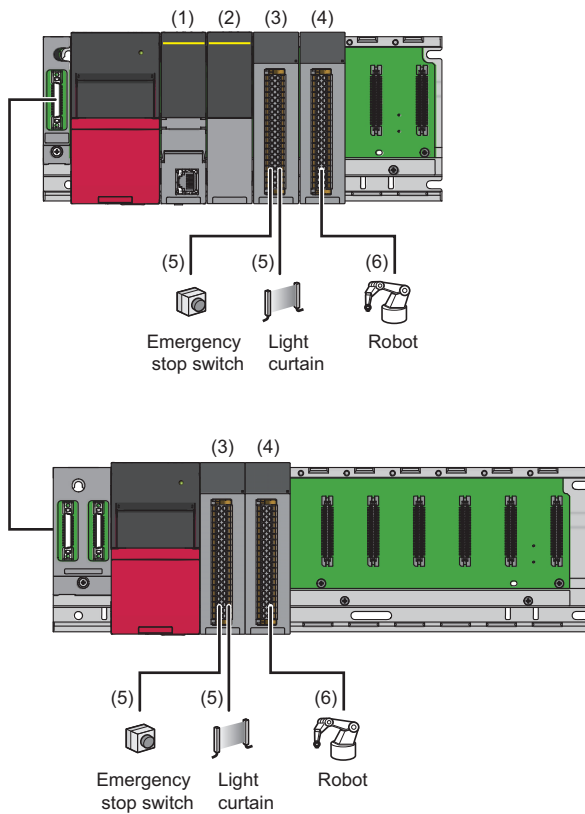

- (1) Safety CPU
- (2) Safety function module
- (3) Input module with safety functions
- (4) Output module with safety functions
- (5) Input signal
- (6) Output signal

For details on the safety I/O refresh function and the settings to perform the safety I/O refresh, refer to the following.

📖 MELSEC iQ-R I/O Module (With Safety Functions) User's Manual

Mounting position of the safety function module

Use the Safety CPU and the Safety function module as a pair.

■Single CPU system

The safety function module is required to be mounted on the main base unit.^{*1} (It cannot be mounted on extension base units.)

^{*1} When using the Safety CPU with firmware version "13" or earlier, mount the safety function module to the right of the Safety CPU. If multiple safety function modules are mounted, the Safety CPU performs safety control with only the safety function module that is mounted at the lowest slot number.

■Multiple CPU system

The safety function module controlled by the Safety CPU is required to be mounted on the main base unit.^{*1} (It cannot be mounted on extension base units.)

^{*1} When using the Safety CPU with firmware version "13" or earlier, mount the safety function module to the right of the Safety CPU. If multiple safety function modules are mounted and the Safety CPU controls them, the Safety CPU performs safety control with only the safety function module that is mounted at the lowest slot number.

For the combinations of CPU modules in a multiple CPU system, refer to the following.

 Page 96 Combinations of CPU modules in a multiple CPU system

Control CPU for safety function module

In a multiple CPU system, the safety function module mounted on the next slot to the Safety CPU is automatically controlled by the Safety CPU when:

- The module configuration diagram or I/O assignment setting for a single CPU system is set to the Safety CPU.
- No parameters are set to the Safety CPU.

If the module configuration diagram or I/O assignment setting for a multiple CPU system is set to the Safety CPU, the safety function module is controlled by the CPU module set in them.

System using the SIL2 Process CPU

Use the SIL2 Process CPU with the SIL2 function module as a pair. Programs for safety control and for standard control can be executed simultaneously in one system. These products can be used to construct a safety function for general industrial machinery.

Use the SIL2 Process CPU with the redundant function module as a pair to configure a redundant system.

Mount the modules on the slots from the CPU slot to slot number 1 in the order of the SIL2 Process CPU, SIL2 function module, and redundant function module.

I/O modules and intelligent function modules set to SIL2 mode are mounted to the intelligent device station (remote head module) on CC-Link IE Field Network.

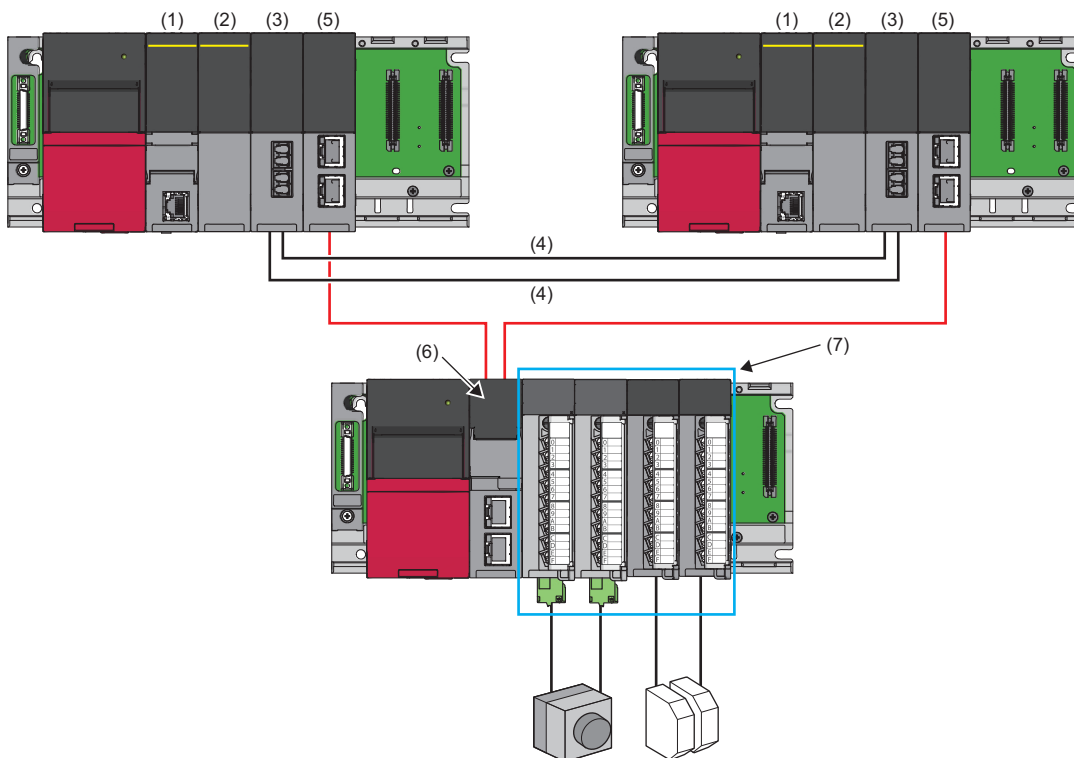

- (1) SIL2 Process CPU
- (2) SIL2 function module
- (3) Redundant function module
- (4) Tracking cable
- (5) CC-Link IE Field Network master/local module
- (6) Remote head module
- (7) Modules set to SIL2 mode ([Page 66 Configuration of a system using the SIL2 Process CPU](#))

For details on the functions of the SIL2 Process CPU, refer to the following.

[MELSEC iQ-R CPU Module User's Manual \(Application\)](#)

Point

- The mounting positions and order are as described above. They cannot be changed.
- The SIL2 Process CPU and the SIL2 function module must be of the same pair version. Check the pair version with the rating plate on the side of the module, special register, or buffer memory (SIL2 Process CPU: SD206, SIL2 function module: Un\G60). ([Page 210 Rating plate](#), [Page 244 Pair Version](#))

Configuration of a system using the SIL2 Process CPU

The following table lists system configuration for systems using the SIL2 Process CPU on CC-Link IE Field Network.

System configuration		Overview
Redundant specified station	Redundant master station	A redundant configuration of the master station is available.
Redundant configuration of entire network	Redundant line	A redundant configuration of the entire network including the master station and transmission path is available. The redundant line is configured in combination with the redundant master station and the redundant intelligent device station with remote head modules. When a communication error occurs in the master station, the control is continued by switching systems together with the network instead of switching the faulty station only. In addition, the time required for system switching is shorter than that for the redundant master station.

There are no restrictions on network topologies. However, the ring topology is recommended to configure a redundant system because the loopback function avoids system switching caused by a cable disconnection or a faulty station in a system.

■ Redundant master station

Mount a CC-Link IE Field Network master/local module on each of the base units of the control system and standby system. If an error occurs in the master station of the control system, the submaster station of the standby system performs control.

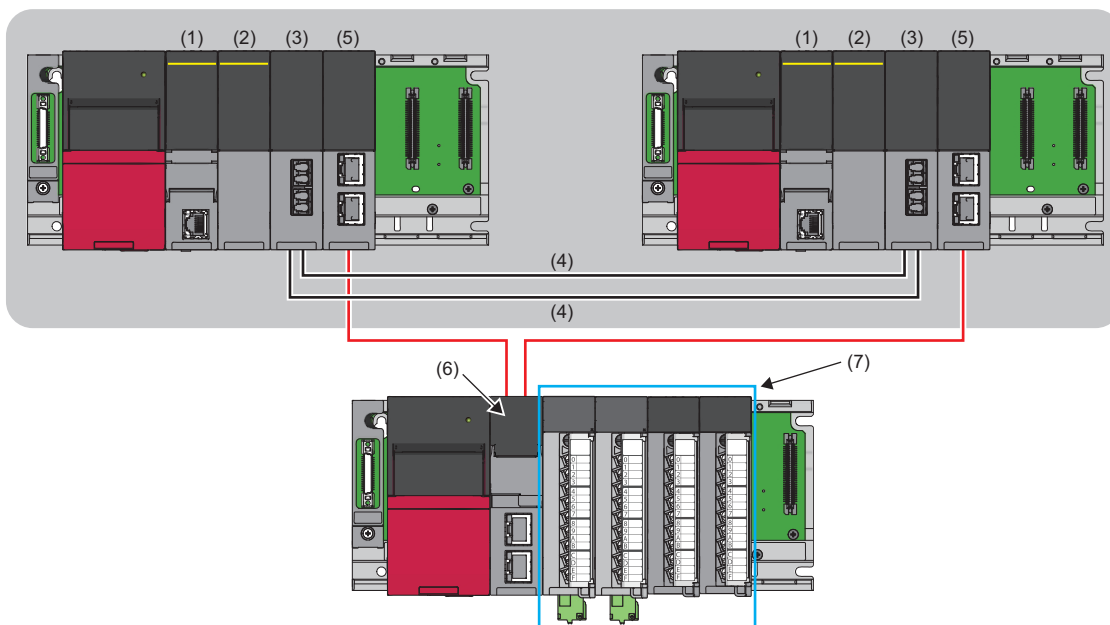

- (1) SIL2 Process CPU
- (2) SIL2 function module
- (3) Redundant function module
- (4) Tracking cable
- (5) CC-Link IE Field Network master/local module
- (6) Remote head module
- (7) Modules set to SIL2 mode

Point

For the redundant master station, safety communications with a redundant intelligent device station (safety station) cannot be performed. To perform, configure the redundant line. (➔ Page 67 Redundant line)

For details, refer to "Redundant System Function" in the following.

📖 MELSEC iQ-R CC-Link IE Field Network User's Manual (Application)

■Redundant line

A redundant configuration of network lines is available.

Mount a CC-Link IE Field Network master/local module on each of the base units of the control system and standby system in the master station where a redundant configuration has been configured. Mount two remote head modules on each base unit of intelligent device stations for the redundant configuration of the remote head module. Connect the master station to the remote head modules of the control system and do the same for the standby system. With a redundant configuration of network lines, control is performed on a network of the standby system if an error occurs on the network of the control system.

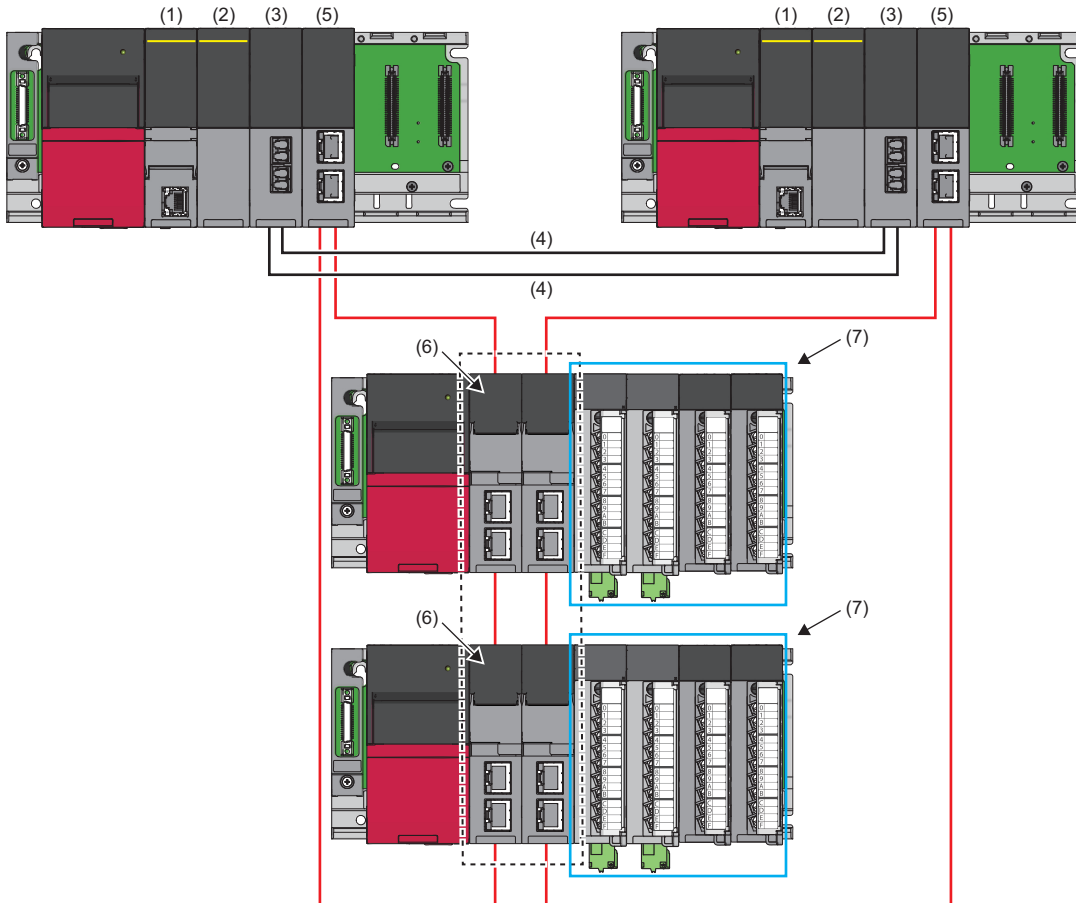

- (1) SIL2 Process CPU
- (2) SIL2 function module
- (3) Redundant function module
- (4) Tracking cable
- (5) CC-Link IE Field Network master/local module
- (6) Remote head module
- (7) Modules set to SIL2 mode

For details, refer to "Redundant System Function" in the following.

📖 MELSEC iQ-R CC-Link IE Field Network User's Manual (Application)

■For safety digital input/output

To perform safety digital input/output in a system using the SIL2 Process CPU, mount the two RX40NC6Bs and two RY40PT5Bs which are set to SIL2 mode, to the right of the remote head module.

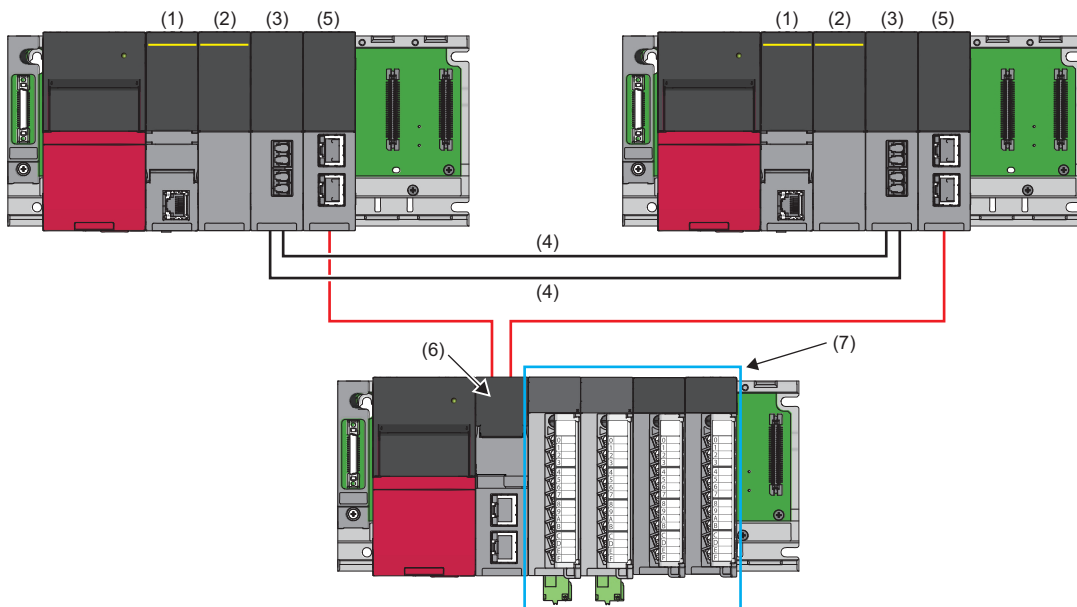

- (1) SIL2 Process CPU
- (2) SIL2 function module
- (3) Redundant function module
- (4) Tracking cable
- (5) CC-Link IE Field Network master/local module
- (6) Remote head module
- (7) Two RX40NC6Bs and two RY40PT5Bs (These four modules are set to SIL2 mode.)

For details, refer to the following.

📖 MELSEC iQ-R I/O Module (With Diagnostic Functions) User's Manual (Application)

■ For safety analog input

To perform safety analog input in a system using the SIL2 Process CPU, mount the two R60AD8-Gs, one R60DA8-G, and one RY40PT5B which are set to SIL2 mode, to the right of the remote head module.

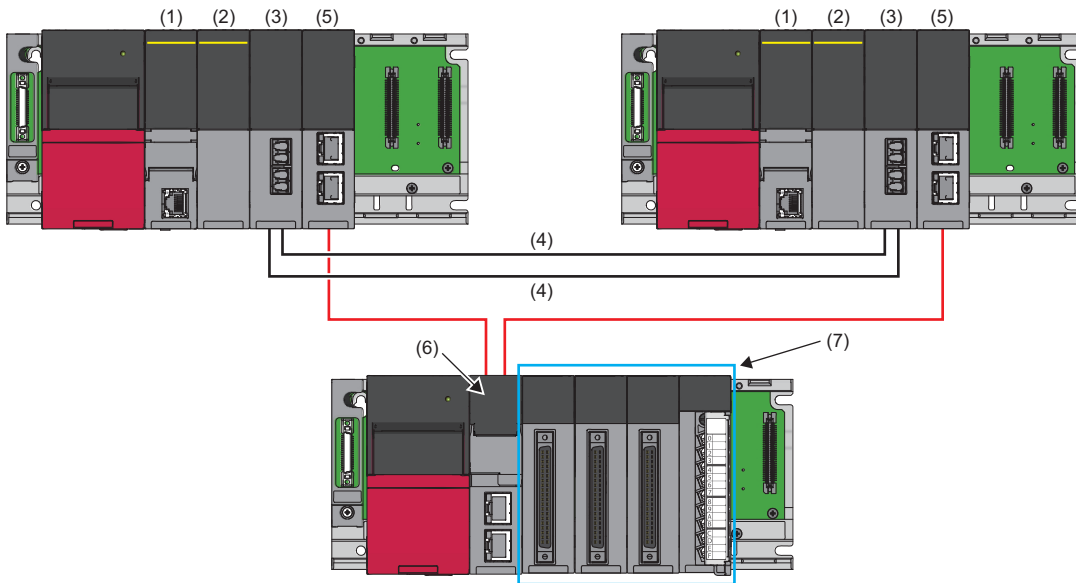

- (1) SIL2 Process CPU
- (2) SIL2 function module
- (3) Redundant function module
- (4) Tracking cable
- (5) CC-Link IE Field Network master/local module
- (6) Remote head module
- (7) Two R60AD8-Gs, one R60DA8-G, and one RY40PT5B (These four modules are set to SIL2 mode.)

For details, refer to the following.

📖 MELSEC iQ-R Channel Isolated Analog-Digital Converter Module User's Manual (Application)

■For safety analog output

To perform safety analog output in a system using the SIL2 Process CPU, mount the one R60DA8-G, one R60AD8-G, and one RY40PT5B-AS which are set to SIL2 mode, to the right of the remote head module.

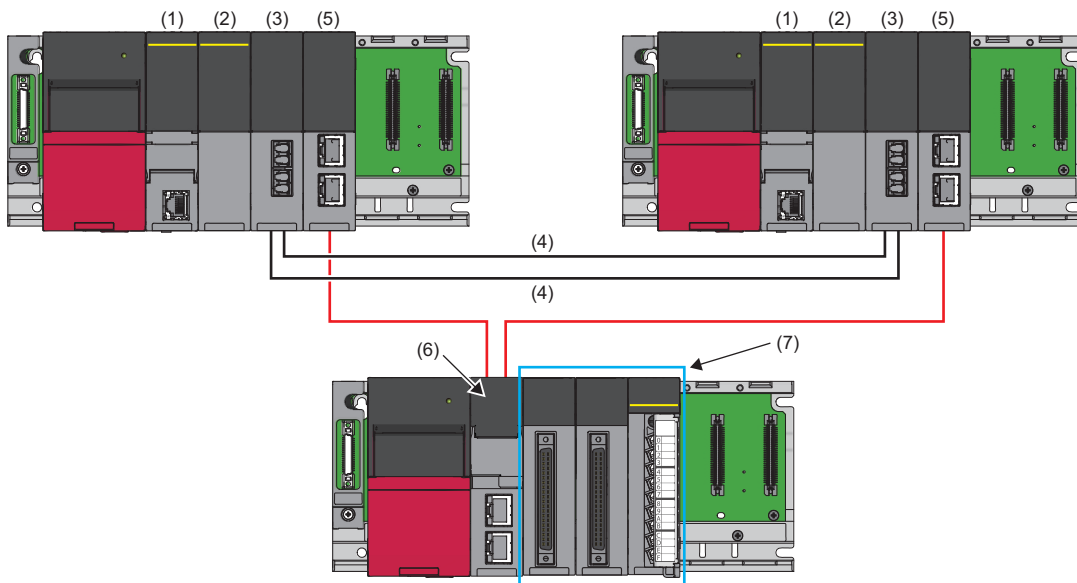

- (1) SIL2 Process CPU
- (2) SIL2 function module
- (3) Redundant function module
- (4) Tracking cable
- (5) CC-Link IE Field Network master/local module
- (6) Remote head module
- (7) One R60DA8-G, one R60AD8-G, one RY40PT5B-AS (These three modules are set to SIL2 mode.)

For details, refer to the following.

📖 MELSEC iQ-R Channel Isolated Digital-Analog Converter Module User's Manual (Application)

Redundant configuration of power supply modules

A redundant configuration of redundant power supply modules is available when two redundant power supply modules are mounted on a redundant power supply base unit. (☞ Page 74 Lists of Configuration Devices)

Even if one power supply module has failed or an error occurs with its power supply system, system operation can be continued with the other power supply module.

The power supply system error can be cleared or the defective power supply module can be replaced during system operation. As preventive maintenance, a power supply module can be replaced during system operation. (☞ Page 209 Replacement procedure of redundant power supply modules)

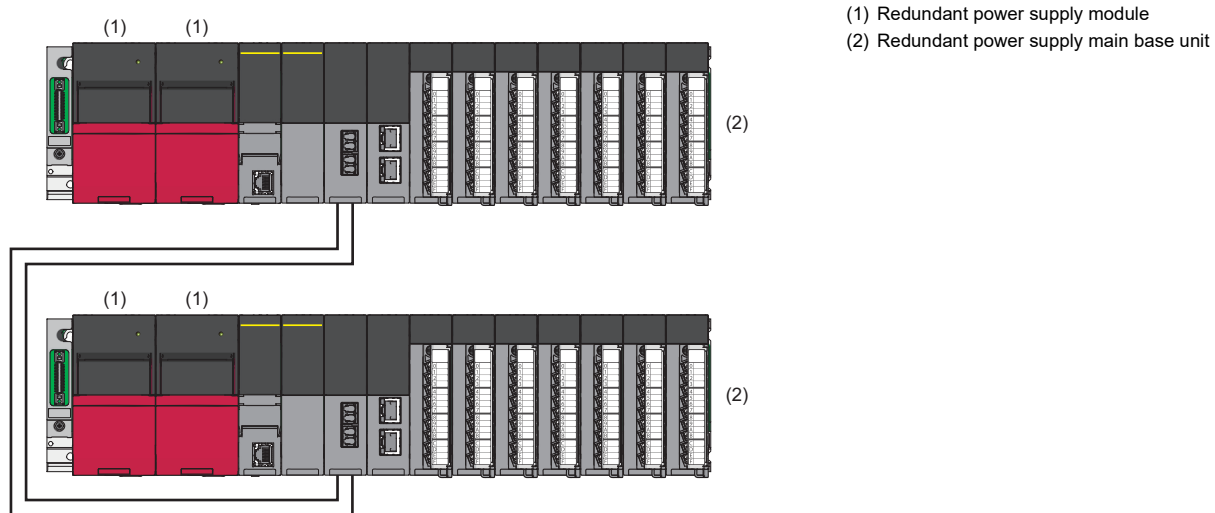

Redundant configuration of CC-Link IE Controller Network

By mounting a CC-Link IE Controller Network module on each of the base units of the control system and standby system, the new control system can continue data link if an error occurs in the control system.

For details, refer to "Redundant System Function" in the following.

☞ MELSEC iQ-R CC-Link IE Controller Network User's Manual (Application)

Redundant configuration of CC-Link

By mounting a CC-Link system master/local module on each of the base units of the control system and standby system, system switching due to a stop error of a CPU module can be supported with the standby master function.

For details, refer to "How to Use Standby Master Function in Redundant System" in the following.

☞ MELSEC iQ-R CC-Link System Master/Local Module User's Manual (Application)

Settings specific to systems using the SIL2 Process CPU

To configure a system using the SIL2 Process CPU, select a model for the systems using the SIL2 Process CPU with the engineering tool. The following describes the modules for which users need to select an operation mode and a model for the systems using the SIL2 Process CPU.

■CPU module

The operation mode for the SIL2 Process CPU is fixed to "Redundant".

Window

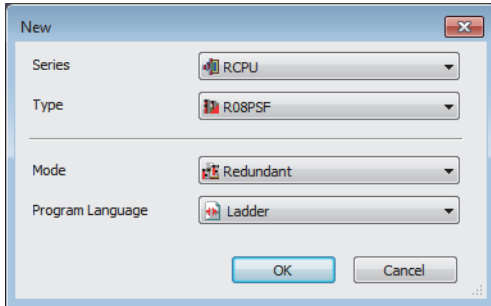

■CC-Link IE Field Network

When placing a module on the "Module Configuration" window or adding a module on the "Navigation window" in the engineering tool, select a proper model depending on whether the remote head module is redundant or not.

Configuration	CC-Link IE Field Network master/local module	Remote head module
When the remote head module is redundant (Redundant line)	RJ71GF11-T2(LR)	RJ72GF15-T2(LR)
When the remote head module is not redundant (Redundant master station)	RJ71GF11-T2(MR)	RJ72GF15-T2

Select a model name for the remote head module at project creation.

Window

- Project creation

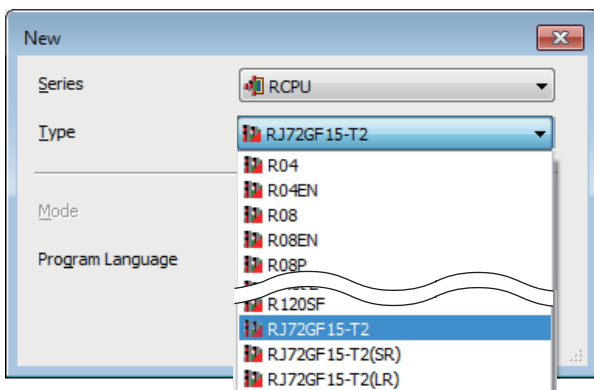

- "Element Selection" window of "Module Configuration" (CC-Link IE Field Network master/local module)

RJ71GF11-T2	CC IE Field
RJ71GF11-T2(LR)	CC IE Field(Redundant line system)
RJ71GF11-T2(MR)	CC IE Field(Redundant master stations)
RJ71GF11-T2(SR)	CC IE Field(Redundant slave stations)

- "Element Selection" window of "Module Configuration" (Remote head module)

Head Module	
RJ72GF15-T2	CC IE Field
RJ72GF15-T2(LR)	CC IE Field(Redundant line)
RJ72GF15-T2(SR)	CC IE Field(Redundant slave stations)

Point

The RJ71GF11-T2(LR) and RJ71GF11-T2(MR) are model names on the engineering tool for using the RJ71GF11-T2 in a system using the SIL2 Process CPU. (Equivalent model names have been prepared for remote head modules.)

(LR) and (MR) of the model names are abbreviations as follows.



- LR: Line Redundant
- MR: Master Redundant

■ Modules to be mounted to the intelligent device station (remote head module)

When placing a module on the "Module Configuration" window or adding a module from the "Navigation window", select a model name which has "(S2M)" or "(S2S)" on its ending in the engineering tool. For example, select "RX40NC6B(S2M)" or "RX40NC6B(S2S)" for the input module with diagnostic functions.

Window

- "Element Selection" window of "Module Configuration"

 RX40NC6B	16 points(Negative common type)
 RX40NC6B(S2M)	16 points(Negative common type)
 RX40NC6B(S2S)	16 points(Negative common type)

For details, refer to the following.

 Manuals for each module used

Point

"(S2M)" and "(S2S)" after the model name are the model names displayed on the engineering tool for using the RJ71GF11-T2 in a system using the SIL2 Process CPU.

"(S2M)" and "(S2S)" are the abbreviations for the following.

- S2M: SIL2 mode Main
- S2S: SIL2 mode Sub

1.2 Lists of Configuration Devices

The following table lists products that can be used in the MELSEC iQ-R series system.

For the modules that are not described in this chapter, refer to the manuals for each module used.

 Manuals for each module used

MELSEC iQ-R series

The following table lists the configuration devices and the availability of each CPU module and remote head module.

Note that there are restrictions on the usable firmware version of CPU modules and the remote head module or the usable functions and firmware version of each module, depending on the combination of modules used. Refer to the manuals for each module used at the same time.

CPU modules and remote head modules are abbreviated as follows:

Symbol	Description
Rn	RnCPU
RnEN	RnENCPU
RnP(P)	Process CPU (process mode)
RnP(R)	Process CPU (redundant mode)
RnP(R)(M)	Process CPU (redundant mode) (main base unit)
RnP(R)(E)	Process CPU (redundant mode) (extension base unit in a redundant system with redundant extension base unit ^{*1})
RnPSF	SIL2 Process CPU
RnSF	Safety CPU
RnC	C Controller module
RnW	MELSECWinCPU module
RnMT	Motion CPU
RnRT	Robot CPU
RnNC	NCCPU
Rem	Remote head module
Rem(R)	Remote head module (redundant system)

*1 To configure a redundant system with redundant extension base unit, there are restrictions on the firmware version of the CPU module. ( MELSEC iQ-R CPU Module User's Manual (Application))

○: Available, ×: Not available

Main base unit

Item	Model	Rn	RnEN	RnP (P)	RnP (R)	RnPSF	RnSF	RnC	RnW	RnMT	RnRT	RnNC	Rem	Rem (R)
Main base unit	R33B, R35B, R38B, R312B	○	○	○	○	○	○	○	○	○	○	○	○	○
Slim type main base unit	R32SB, R33SB, R35SB	○	○	○	○	×	×	×	×	○	×	×	○	○
Extended temperature range main base unit	R310B-HT	○	×	○	○	○	○	○	×	○	×	×	○	○
Redundant power supply main base unit	R310RB	○ ^{*1}	○ ^{*1}	○	○	○	×	×	×	×	×	×	○	○
Extended temperature range redundant power supply main base unit	R38RB-HT	○ ^{*1}	×	○	○	○	×	×	×	×	×	×	○	○

*1 When a redundant power supply system is configured, there are restrictions on the firmware version of the CPU module. ( MELSEC iQ-R CPU Module User's Manual (Application))

Extension base unit and extension cable

Item	Model	Rn	RnEN	RnP (P)	RnP (R)	RnPSF	RnSF	RnC	RnW	RnMT	RnRT	RnNC	Rem	Rem (R)
Extension base unit	R65B, R68B, R612B	○	○	○	○	×	○	○	○	○	× ^{*1}	× ^{*1}	○	○
Extended temperature range extension base unit	R610B-HT	○	×	○	○	×	○	○	×	○	× ^{*1}	× ^{*1}	○	○
Redundant power supply extension base unit	R610RB	○ ^{*2}	○ ^{*2}	○	○	×	×	×	×	×	× ^{*1}	× ^{*1}	○	○
Extended temperature range redundant power supply extension base unit	R68RB-HT	○ ^{*2}	×	○	○	×	×	×	×	×	× ^{*1}	× ^{*1}	○	○
Redundant extension base unit	R68WRB	×	×	×	○ ^{*3}	×	×	×	×	×	×	×	×	×
Extended temperature range redundant extension base unit	R66WRB-HT	×	×	×	○ ^{*3}	×	×	×	×	×	×	×	×	×
RQ extension base unit	RQ65B, RQ68B, RQ612B	○	○	○	×	×	○	○	○	×	× ^{*1}	× ^{*1}	○	○
Extension cable	RC06B, RC12B, RC30B, RC50B, RC100B	○	○	○	○	×	○	○	○	○	× ^{*1}	× ^{*1}	○	○

*1 When a multiple CPU system is configured, the programmable controller system can be extended if there are no modules controlled by the Motion CPU, NCCPU, or robot CPU on the extension base unit.

*2 When a redundant power supply system is configured, there are restrictions on the firmware version of the CPU module. (📖 MELSEC iQ-R CPU Module User's Manual (Application))

*3 There are restrictions on the firmware version of the CPU module. (📖 MELSEC iQ-R CPU Module User's Manual (Application))

Power supply module

Item	Model	Rn	RnEN	RnP (P)	RnP (R)	RnPSF	RnSF	RnC	RnW	RnMT	RnRT	RnNC	Rem	Rem (R)
Power supply module	R61P, R63P, R64P, R69P	○	○	○	○ ^{*3}	○	○	○	○	○	○	○	○	○
	R62P	○	○	○	○ ^{*3}	× ^{*2}	○	○	× ^{*2}	○	○	○	○	○
Slim type power supply module	R61SP	○	○	○	○	× ^{*4}	×	×	× ^{*4}	○	× ^{*4}	× ^{*4}	○	○
Redundant power supply module	R63RP, R64RP, R69RP	○ ^{*1}	○ ^{*1}	○	○	○	×	×	×	×	×	×	○	○

*1 When a redundant power supply system is configured, there are restrictions on the firmware version of the CPU module. (📖 MELSEC iQ-R CPU Module User's Manual (Application))

*2 The R62P cannot be used because the current consumption of the system exceeds the rated output current of the R62P.

*3 These modules cannot be mounted on the redundant extension base unit. (📖 Page 95 Combinations of a base unit and a power supply module)

*4 The R61SP cannot be used because the current consumption of the system exceeds the rated output current of the R61SP.

CPU module

Item	Model	Rn	RnEN	RnP (P)	RnP (R)	RnPSF	RnSF	RnC	RnW	RnMT	RnRT	RnNC	Rem	Rem (R)	
Programmable controller CPU	R00CPU, R01CPU, R02CPU, R04CPU, R04ENCPU*1, R08CPU, R08ENCPU*1, R16CPU, R16ENCPU*1, R32CPU, R32ENCPU*1, R120CPU, R120ENCPU*1	☞ Page 96 Combinations of CPU modules in a multiple CPU system													
Process CPU*2	R08PCPU, R16PCPU, R32PCPU, R120PCPU														
Motion CPU	R16MTCPU, R32MTCPU, R64MTCPU														
NCCPU	R16NCCPU														
Robot CPU	R16RTCPU														
C Controller module	R12CCPU-V														
SIL2 Process CPU*3	R08PSFCPU, R16PSFCPU, R32PSFCPU, R120PSFCPU														
Safety CPU*4	R08SFCPU, R16SFCPU, R32SFCPU, R120SFCPU														
MELSECWinCPU module	R102WCPU-W														

*1 RnENCPU is a module with the integrated CPU module/network functionality. When setting the engineering tool, select a network for the RnENCPU (network part) under "CPU Extension". (☞ MELSEC iQ-R Ethernet/CC-Link IE User's Manual (Startup))

*2 To configure a redundant system, use redundant function modules and operate Process CPUs in redundant mode. When a firmware version of a Process CPU (redundant mode) to be used is "06" or earlier, use the Process CPUs with a firmware version "06" or earlier in both systems.

For the configuration of a redundant system, refer to the following.

☞ Page 46 Redundant system

*3 The SIL2 function module and the redundant function module must be mounted on the right of the SIL2 Process CPU. For the configuration of a system using the SIL2 Process CPU, refer to the following.

☞ Page 65 System using the SIL2 Process CPU

*4 Use the Safety CPU and the Safety function module as a pair. (☞ Page 62 System using the Safety CPU)

CPU module extension

Item	Model	Rn	RnEN	RnP (P)	RnP (R) (M)	RnP (R) (E)	RnPSF	RnSF	RnC	RnW	RnMT	RnRT	RnNC	Rem	Rem (R)
Redundant function module	R6RFM	×	×	×	○	×	○*1	×	×	×	×	×	×	×	×
SIL2 function module	R6PSFM	×	×	×	×	×	○*2	×	×	×	×	×	×	×	×
Safety function module	R6SFM	×	×	×	×	×	×	○*3	×	×	×	×	×	×	×

*1 Use the redundant function module in combination with the Process CPU or SIL2 Process CPU. (☞ Page 46 Redundant system, Page 65 System using the SIL2 Process CPU)

*2 Use the SIL2 function module in combination with the SIL2 Process CPU. (☞ Page 65 System using the SIL2 Process CPU)

*3 Use the Safety CPU and the Safety function module as a pair. (☞ Page 62 System using the Safety CPU)

Remote head module

Item	Model	Rn	RnEN	RnP (P)	RnP (R)	RnPSF	RnSF	RnC	RnW	RnMT	RnRT	RnNC	Rem	Rem (R)
CC-Link IE Field Network	RJ72GF15-T2	—	—	—	—	—	—	—	—	—	—	—	—	—

SD memory card

Item	Model	Rn	RnEN	RnP (P)	RnP (R)	RnPSF	RnSF	RnC	RnW	RnMT	RnRT	RnNC	Rem	Rem (R)
SD memory card	NZ1MEM-2GBSD, NZ1MEM-4GBSD, NZ1MEM-8GBSD, NZ1MEM-16GBSD	○ ^{*1}	○	○	○	○	○	○	○	○	○	○	○	○
	L1MEM-2GBSD, L1MEM-4GBSD	○ ^{*2}	×	×	×	×	×	×	×	×	×	×	×	×

*1 Use this device with the RnCPU except the R00CPU.

*2 Use these devices with the R04CPU, R08CPU, R16CPU, R32CPU, R120CPU.

CFast card

Item	Model	Rn	RnEN	RnP (P)	RnP (R)	RnPSF	RnSF	RnC	RnW	RnMT	RnRT	RnNC	Rem	Rem (R)
CFast card	NZ1MEM-16GBCFT, NZ1MEM-32GBCFT, NZ1MEM-64GBCFT	×	×	×	×	×	×	×	○	×	×	×	×	×

Cassette

Item	Model	Rn	RnEN	RnP (P)	RnP (R)	RnPSF	RnSF	RnC	RnW	RnMT	RnRT	RnNC	Rem	Rem (R)
Extended SRAM cassette	NZ2MC-1MBS	○ ^{*1}	○	×	×	×	○	×	×	×	×	×	×	×
	NZ2MC-2MBS	○ ^{*1}	○	×	×	×	○	×	×	×	×	×	×	×
	NZ2MC-4MBS	○ ^{*1}	○	×	×	×	○	×	×	×	×	×	×	×
	NZ2MC-8MBS	○ ^{*1}	○	×	×	×	○	×	×	×	×	×	×	×
	NZ2MC-16MBS	○ ^{*1*2}	○	×	×	×	×	×	×	×	×	×	×	×
	NZ2MC-2MBSE	×	×	○	○	○	○	×	×	×	×	×	×	×
	NZ2MC-8MBSE	×	×	○	○	○	○	×	×	×	×	×	×	×
Battery-less option cassette	NZ1BLC	○ ^{*1*2}	○ ^{*2}	×	×	×	×	×	×	×	×	×	×	×

*1 Use these devices with the R04CPU, R08CPU, R16CPU, R32CPU, R120CPU.

*2 There are restrictions on the firmware version. (MELSEC iQ-R CPU Module User's Manual (Application))

Battery

Item	Model	Rn	RnEN	RnP (P)	RnP (R)	RnPSF	RnSF	RnC	RnW	RnMT	RnRT	RnNC	Rem	Rem (R)
Battery	Q6BAT, Q7BATN, Q7BATN-SET, Q7BAT, Q7BAT-SET	○ ^{*1}	○	○	○	○	○	×	×	×	×	×	×	×
	FX3U-32BL	○ ^{*2}	×	×	×	×	×	×	○	×	×	×	×	×

*1 Use this device with the R04CPU, R08CPU, R16CPU, R32CPU, R120CPU.

*2 Use this device with the R00CPU, R01CPU, R02CPU.

I/O module

Item	Model	Rn	RnEN	RnP (P)	RnP (R) (M)	RnP (R) (E)	RnPSF	RnSF	RnC	RnW	RnMT	RnRT	RnNC	Rem	Rem (R)
AC input module	RX10	○	○	○	○	○	○	○	○	○	○	○	×	○	○
	RX10-TS	○	○	○	○	○	○	○	○	×	×	×	×	○	○
	RX28	○	○	○	○	○	○	○	○	○	×	○	×	○	○
DC input module	RX40C7, RX41C4, RX42C4	○	○	○	○	○	○	○	○	○	○	○	×	○	○
	RX40C7-TS, RX41C4-TS	○	○	○	○	○	○	○	○	×	×	×	×	○	○
	RX70C4, RX71C4, RX72C4	○	○	○	○	○	○	○	×	×	×	×	×	○	○
DC high-speed input module	RX40PC6H, RX40NC6H	○	○	○	○	○	○	○	○	○	○	×	×	○	○
	RX41C6HS, RX61C6HS	○	○	○	○	○	○	○	○	○	○	×	×	○	○
Input module with diagnostic functions	RX40NC6B	○	○	○	○	○ ^{*3}	○ ^{*2*5}	○	○	○	×	×	×	○	○
Input module with safety functions	RX40NC6S-TS	×	×	×	×	×	×	○ ^{*4}	×	×	×	×	×	×	×
Contact output module	RY10R2	○	○	○	○	○	○	○	○	○	○	○	×	○	○
	RY10R2-TS	○	○	○	○	○	○	○	○	×	×	×	×	○	○
	RY18R2A	○	○	○	○	○	○	○	○	○	×	○	×	○	○
Triac output module	RY20S6	○	○	○	○	○	○	○	○	○	×	○	×	○	○
Transistor output module	RY40NT5P, RY41NT2P, RY42NT2P, RY40PT5P, RY41PT1P, RY42PT1P	○	○	○	○	○	○	○	○	○	○	○	×	○	○
	RY40NT5P-TS, RY41NT2P-TS, RY40PT5P-TS, RY41PT1P-TS	○	○	○	○	○	○	○	○	×	×	×	×	○	○
Transistor high-speed output module	RY41NT2H, RY41PT2H	○	○	○	○	○	○	○	○	○	○	○	×	○	○
Output module with diagnostic functions	RY40PT5B	○	○	○	○	○ ^{*3}	○ ^{*2*5}	○	○	○	×	×	×	○	○
SIL2 analog control output module	RY40PT5B-AS	×	×	×	×	×	○ ^{*2*5}	×	×	×	×	×	×	×	×
Output module with safety functions	RY48PT20S-TS	×	×	×	×	×	×	○ ^{*4}	×	×	×	×	×	×	×
I/O combined module	RH42C4NT2P	○	○	○	○	○	○	○	○	○	○	○	×	○	○
Dual signal module	R173SXY	×	×	×	×	×	×	×	×	×	×	×	○ ^{*1}	×	×

- *1 Up to three dual signal modules can be connected to one NCCPU.
- *2 When using these modules in SIL2 mode, mount them with the intelligent device station (remote head module) on CC-Link IE Field Network. They cannot be used with the main base unit on which the SIL2 Process CPU is mounted. (📖 Page 65 System using the SIL2 Process CPU)
- *3 For the restrictions when using the modules on an extension base unit in a redundant system with redundant extension base unit, refer to the following.
📖 Manuals for each module used
- *4 There are restrictions on the firmware version. (📖MELSEC iQ-R CPU Module User's Manual (Application))
- *5 In the configuration in SIL2 mode, this module can be used for communication using safety protocol version 1. For the restrictions when using the module in SIL2 mode, refer to the following.
📖MELSEC iQ-R CC-Link IE Field Network User's Manual (Application)

Intelligent function module

Item	Model	Rn	Rn EN	RnP (P)	RnP (R) (M)	RnP (R) (E)	RnP SF	RnSF	RnC	RnW	Rn MT	Rn RT	Rn NC	Rem	Rem (R)
Analog-digital converter module	R60AD4, R60ADI8, R60ADV8	○	○	○	×	○ ^{*18}	×	○	○ ^{*7}	○	○	×	×	○	○
Channel isolated analog-digital converter module	R60AD8-G	○	○	○	×	○ ^{*18}	○ ^{*11} *23	○	○ ^{*7}	○	○	×	×	○	○
	R60AD16-G ^{*2}	○	○	○	×	○ ^{*18}	×	○	○ ^{*7}	○	○	×	×	○	○
Channel isolated analog-digital converter module (with signal conditioning function)	R60AD6-DG	○	○	○	×	○ ^{*18}	×	○	○	○	×	×	×	○	○
High speed analog-digital converter module	R60ADH4	○	○	○	×	○ ^{*18}	×	○	○	○	○	×	×	○	○
HART-enabled analog-digital converter module	R60ADI8-HA	○	○	○	×	○ ^{*18}	×	○	×	×	×	×	×	○	○
Digital-analog converter module	R60DA4, R60DAI8, R60DAV8	○	○	○	×	○ ^{*18}	×	○	○ ^{*7}	○	○	×	×	○	○
Channel isolated digital-analog converter module	R60DA8-G	○	○	○	×	○ ^{*18}	○ ^{*11} *23	○	○ ^{*7}	○	○	×	×	○	○
	R60DA16-G ^{*2}	○	○	○	×	○ ^{*18}	×	○	○ ^{*7}	○	○	×	×	○	○
High speed digital-analog converter module	R60DAH4	○	○	○	×	○ ^{*18}	×	○	○	○	×	×	×	○	○
Simple Motion module	RD77MS2, RD77MS4, RD77MS8, RD77MS16	○	○	○	×	○ ^{*18}	×	○	○	×	×	×	×	○ ^{*4}	×
	RD77GF4, RD77GF8, RD77GF16, RD77GF32	○	○	○	×	×	×	○ ^{*9}	○	×	×	×	×	×	×
Channel isolated RTD input module	R60RD8-G	○	○	○	×	○ ^{*18}	×	○	○ ^{*7}	○	○	×	×	○	○
Channel isolated thermocouple input module	R60TD8-G	○	○	○	×	○ ^{*18}	×	○	○ ^{*7}	○	○	×	×	○	○
Channel isolated temperature/micro voltage input module	R60TRD4-G	○	○	○	×	○ ^{*18}	×	○	×	○	×	×	×	○	○
Temperature control module	R60TCTR2T T2, R60TCTR2T T2BW, R60TCRT4, R60TCRT4BW	○	○	○	×	○ ^{*18}	×	○	○	○	×	×	×	○	○ ^{*9}
	R60TCTR2T T2-TS, R60TCRT4-TS	○	○	○	×	○ ^{*18}	×	○	○	×	×	×	×	○	○ ^{*9}
High-speed counter module	RD62P2, RD62D2, RD62P2E	○	○	○	×	○ ^{*18}	×	○	○	○	○	×	×	○	○
Channel isolated pulse input module	RD60P8-G	○	○	○	×	○ ^{*18}	×	○	×	×	×	×	×	○	○
Flexible high-speed I/O control module	RD40PD01	○	○	○	×	○ ^{*18}	×	○	○	○	×	×	×	○	○
MES interface module ^{*5}	RD81MES96	○	○	○	×	×	×	○	○	×	×	×	×	×	×
	RD81MES96N	○	○	○	×	×	×	○	○	×	×	×	×	×	×
High speed data logger module ^{*5}	RD81DL96	○	○	○	×	○ ^{*18}	×	○	○	×	×	×	×	×	×

Item	Model	Rn	Rn EN	RnP (P)	RnP (R) (M)	RnP (R) (E)	RnP SF	RnSF	RnC	RnW	Rn MT	Rn RT	Rn NC	Rem	Rem (R)
OPC UA server module	RD81OPC96	○	○	○	○ ^{*6}	×	×	○	○	×	×	×	×	×	×
Recorder module	RD81RC96	○ ^{*12*15}	○ ^{*15}	×	×	×	×	○ ^{*15}	×	×	×	×	×	×	×
Camera recorder module	RD81RC96-CA	○ ^{*12*15}	○ ^{*15}	×	×	×	×	○ ^{*15}	×	×	×	×	×	×	×
High speed data communication module ^{*5}	RD81DC96	○	○	○	×	×	×	○	○	×	×	×	×	×	×
C intelligent function module	RD55UP06-V	○ ^{*12}	○	○	○ ^{*22}	×	○ ^{*22}	○ ^{*9}	○	×	×	×	×	×	×
	RD55UP12-V	○ ^{*12}	○	○	○ ^{*22}	×	○ ^{*22}	○ ^{*9}	○	×	×	×	×	×	×
Positioning module ^{*4}	RD75P2, RD75P4, RD75D2, RD75D4	○	○	○	×	○ ^{*18}	×	○	○	○	×	×	×	○	×
Energy measuring module	RE81WH	○	○	○	×	○	×	○	×	×	×	×	×	×	×
Ethernet ^{*3*19}	RJ71EN71	○	○	○	○ ^{*9}	○ ^{*18}	○ ^{*9}	○	×	×	×	×	×	○	○
CC-Link IE TSN ^{*20}	RJ71GN11-T2	○ ^{*14}	○ ^{*14}	×	×	×	×	○ ^{*14}	○	○	×	×	×	×	×
	RJ71GN11-SX	○ ^{*14}	○ ^{*14}	×	×	×	×	○ ^{*21}	○	×	×	×	×	×	×
	RJ71GN11-EIP	○ ^{*14}	○ ^{*14}	×	×	×	×	○ ^{*21}	×	×	×	×	×	×	×
Motion module	RD78G4, RD78G8, RD78G16, RD78G32, RD78G64, RD78GHV, RD78GHW	○ ^{*14}	○ ^{*14}	×	×	×	×	○ ^{*14}	○	×	×	×	×	×	×
CC-Link IE Controller Network ^{*19*20}	RJ71GP21-SX	○	○	○	○ ^{*9}	×	○ ^{*9}	○	○	○	×	×	×	×	×
	RJ71GP21S-SX	○	○	○	○	×	○	○	○	○	×	×	×	×	×
	RJ71EN71 ^{*1}	○	○	×	×	×	×	○	○	×	×	×	×	×	×
CC-Link IE Field Network ^{*19}	RJ71GF11-T2	○	○	○	○ ^{*9}	×	○ ^{*9}	○	○	×	×	×	×	×	×
	RJ71EN71	○	○	○	×	×	×	○	○	×	×	×	×	×	×
MODBUS/TCP ^{*9}	RJ71EN71	○	○	○	○	○ ^{*18}	○	○	×	×	×	×	×	○	○
CC-Link ^{*19*20}	RJ61BT11	○	○	○	○ ^{*9}	○ ^{*18}	○ ^{*9}	○	○	○	×	×	×	○	○
MELSECNET/H network module	RJ71LP21-25	○ ^{*14}	○ ^{*14}	○ ^{*14}	○ ^{*14}	×	×	○ ^{*14}	×	×	×	×	×	×	×
	RJ71BR11	○ ^{*14}	○ ^{*14}	×	×	×	×	○ ^{*14}	×	×	×	×	×	×	×
Serial communication module ^{*19*20}	RJ71C24, RJ71C24-R2, RJ71C24-R4	○	○	○	○ ^{*9*} 17	○ ^{*18}	×	○	○	○	×	×	×	○	○
GPIO interface module	RJ71GB91	○	○	○	×	×	×	○	○	○	×	×	×	×	×
MODBUS ^{*9}	RJ71C24, RJ71C24-R2, RJ71C24-R4	○	○	○	○ ^{*17}	○ ^{*18}	×	○	×	×	×	×	×	○	○
AnyWireASLINK master module ^{*13}	RJ51AW12AL	○	○	○	×	×	×	○	○	○	×	×	×	○	×
BACnet module	RJ71BAC96	○	○	○	×	○	×	○	○	○	×	×	×	○	×
CANopen module	RJ71CN91	○ ^{*8}	○ ^{*8}	○ ^{*8}	×	×	×	○ ^{*8*9}	○ ^{*8}	×	×	×	×	×	×
DeviceNet master/slave module	RJ71DN91	○ ^{*10}	○ ^{*10}	○ ^{*10}	×	○ ^{*18}	×	○ ^{*10}	○	×	×	×	×	×	×
PROFIBUS-DP module ^{*9}	RJ71PB91V	○	○	○	○	○ ^{*18}	○	○	×	×	×	×	×	○	○
Laser displacement sensor control module	R60MH112NA	○	○	○	×	○ ^{*14} ^{*18}	×	○	○	○	○	×	×	○	○
EtherNet/IP	RJ71EIP91	○	○	○	×	×	×	○ ^{*16}	×	×	×	×	×	×	×
	RJ71GN11-EIP	○ ^{*14}	○ ^{*14}	×	×	×	×	○ ^{*21}	×	×	×	×	×	×	×

- *1 When the CC-Link IE Controller Network function of the RJ71EN71 is used, there are restrictions on the firmware versions of the RnCPU, Safety CPU, C Controller module, and RJ71EN71. (📖 User's Manual (Application) for the module used)
- *2 These modules occupy two slots. When these modules are used with the RnCPU or the C Controller module, there are restrictions on each firmware version. (📖 User's Manual (Application) for the CPU module used)
- *3 When the RJ71EN71 is used with a remote head module, there are restrictions on network combinations. (📖 MELSEC iQ-R Ethernet/CC-Link IE User's Manual (Startup))
- *4 When a redundant system is built with a master station of CC-Link IE Field Network, these modules cannot be used with a remote head module.
- *5 Depending on the CPU module used, there are restrictions on the firmware version of these modules. (📖 Manual for each module)
- *6 When an OPC UA server module is used in a redundant system, there are restrictions for constructing the system. (📖 MELSEC iQ-R OPC UA Server Module User's Manual (Application))
Also, in a redundant system, use the Process CPU with firmware version "18" or later. (📖 MELSEC iQ-R CPU Module User's Manual (Application))
- *7 The method for enabling parameters differs depending on the firmware version of the C Controller module. (📖 MELSEC iQ-R C Controller Module User's Manual)
- *8 The refresh settings are restricted depending on the firmware version of the CPU module. (📖 MELSEC iQ-R CANopen Module User's Manual (Application))
- *9 There are restrictions on the firmware version. (📖 Manual for each module)
- *10 Use the RnCPU with firmware version "28" or later, the RnENCPU with firmware version "17" or later, the Process CPU (process mode) with firmware version "12" or later, and the Safety CPU with firmware version "14" or later. When the CPU module with a firmware version earlier than this version is used, there are restrictions on "Refresh Setting" in "Module Parameter".
- *11 When using these modules in SIL2 mode, mount them with the intelligent device station (remote head module) on CC-Link IE Field Network. They cannot be used with the main base unit on which the SIL2 Process CPU is mounted. (📖 Page 65 System using the SIL2 Process CPU)
- *12 These modules cannot be used with the R00CPU, R01CPU, and R02CPU.
- *13 The iQSS functions are restricted depending on the system configuration. (📖 iQ Sensor Solution Reference Manual)
- *14 There are restrictions on the firmware version. (📖 MELSEC iQ-R CPU Module User's Manual (Application))
- *15 There are restrictions on the firmware version and production information. (📖 MELSEC iQ-R CPU Module User's Manual (Application))
- *16 There are restrictions on the firmware version. (📖 Manual for each module)
The module cannot be available for the safety communications.
- *17 For details on a redundant system in which serial communication is used, refer to the following.
📖 Page 56 Redundant system for serial communication
- *18 For the restrictions when using the modules on an extension base unit in a redundant system with redundant extension base unit, refer to the following.
📖 Manuals for each module used
- *19 Read the precautions before configuring a C Controller system. (📖 Page 106 When using MELSEC iQ-R series modules)
- *20 Read the precautions before configuring a MELSECWinCPU module system. (📖 Page 108 When using MELSEC iQ-R series modules)
- *21 There are restrictions on the firmware version. (📖 MELSEC iQ-R CPU Module User's Manual (Application))
The module cannot be available for the safety communications.
- *22 There are restrictions on the firmware version and functions. (📖 Manual for each module)
- *23 In the configuration in SIL2 mode, this module can be used for communication using safety protocol version 1. For the restrictions when using the module in SIL2 mode, refer to the following.
📖 MELSEC iQ-R CC-Link IE Field Network User's Manual (Application)

Blank cover module

Item	Model	Rn	RnEN	RnP (P)	RnP (R)	RnPSF	RnSF	RnC	RnW	RnMT	RnRT	RnNC	Rem	Rem (R)
Blank cover module	RG60	○	○	○	○	○	○	○	○	○	○	○	○	○

MELSEC-Q series

The following table lists the MELSEC-Q series modules and extension cables which can be used in the MELSEC iQ-R series system.

To use MELSEC-Q series modules and extension cables in the MELSEC iQ-R series system, connect the RQ extension base unit or MELSEC-Q series extension base units under the RQ extension base unit. (☞ Page 170 Connection Method for the Extension Base Unit)

When a MELSEC-Q series module is used, refer to the following.

☞ Page 248 How to Use MELSEC-Q Series Modules

Item	Model	
Base unit	Extension base unit	Q52B, Q55B, Q63B, Q65B, Q68B, Q612B
	Q series large type extension base unit ^{*5*9}	Q55BL, Q65BL, Q68BL
	Q series large type extension base unit (AnS series size) ^{*5*9}	Q55BLS, Q65BLS, Q68BLS, Q55BLS-D, Q65BLS-D, Q68BLS-D
Extension cable	QC05B, QC06B, QC12B, QC30B, QC50B, QC100B	
Power supply module	Q61P, Q61P-A1, Q61P-A2, Q62P, Q63P, Q64P, Q64PN, Q61P-D	
I/O module	AC input module ^{*9}	QX10, QX10-TS, QX28
	DC input module ^{*9}	QX40, QX40-TS, QX40-S1, QX41, QX41-S1, QX41-S2, QX42, QX42-S1, QX70, QX71, QX72, QX80, QX80-TS, QX81, QX81-S2, QX82, QX82-S1
	DC high-speed input module ^{*4*9}	QX40H, QX70H, QX80H, QX90H
	AC/DC input module ^{*9}	QX50
	Contact output module ^{*9}	QY10, QY10-TS, QY18A
	Triac output module ^{*9}	QY22
	Transistor output module ^{*9}	QY40P, QY40P-TS, QY41P, QY42P, QY50, QY68A, QY70, QY71, QY80, QY80-TS, QY81P, QY82P
	Transistor high-speed output module ^{*9}	QY41H
	I/O combined module	QH42P, QX48Y57 ^{*9} , QX41Y41P ^{*9}
	Interrupt module ^{*9}	QI60 ^{*2}
	Large type AC input module ^{*5*9}	QX11L, QX21L
	Large type contact output module ^{*5*9}	QY11AL, QY13L
	Large type triac output module ^{*5*9}	QY23L
Large type transistor output module ^{*5*9}	QY51PL	

Item		Model
Intelligent function module	Analog-digital converter module ^{*6*9}	Q64AD, Q68ADV, Q68ADI
	Channel isolated high resolution analog-digital converter module ^{*6*9}	Q64AD-GH
	Channel isolated high resolution analog-digital converter module (with signal conditioning function) ^{*6*9}	Q62AD-DGH
	Channel isolated analog-digital converter module ^{*6*9}	Q68AD-G
	Channel isolated analog-digital converter module (with signal conditioning function) ^{*6*9}	Q66AD-DG
	High speed analog-digital converter module ^{*6*9}	Q64ADH
	Digital-analog converter module ^{*6*9}	Q62DA, Q62DAN, Q64DA, Q64DAN, Q68DAV, Q68DAVN, Q68DAI, Q68DAIN
	Channel isolated digital-analog converter module ^{*6*9}	Q62DA-FG, Q66DA-G
	High speed digital-analog converter module ^{*6*9}	Q64DAH
	Analog input/output module ^{*6*9}	Q64AD2DA
	Load cell input module ^{*6*9}	Q61LD
	Current transformer input module ^{*6*9}	Q68CT
	RTD input module ^{*6*9}	Q64RD
	Channel isolated RTD input module ^{*6*9}	Q64RD-G, Q68RD3-G
	Thermocouple input module ^{*6*9}	Q64TD
	Channel isolated thermocouple/micro voltage input module ^{*6*9}	Q64TDV-GH
	Channel isolated thermocouple input module ^{*6*9}	Q68TD-G-H01, Q68TD-G-H02
	Temperature control module ^{*6*9}	Q64TCTN, Q64TCRTN, Q64TCTTBWN, Q64TCRTBWN
	Loop control module ^{*9}	Q62HLC
	Multichannel high-speed counter module ^{*9}	QD63P6
	4Mpps capable high-speed counter module ^{*9}	QD64D2
	Channel isolated pulse input module ^{*9}	QD60P8-G
	Multi function counter/timer module	QD65PD2
	Positioning module ^{*3*9}	QD70P4, QD70P8, QD70D4, QD70D8, QD73A1
	Positioning module with built-in counter function ^{*3*9}	QD72P3C3
	MES interface module ^{*2*5*7*9}	QJ71MES96, QJ71MES96N
	Web server module ^{*2*5*7*9}	QJ71WS96
	CC-Link/LT master module ^{*9}	QJ61CL12
	AnyWire DB A20 master module	QJ51AW12D2
	MELSECNET/H network module ^{*1*8*9}	QJ71LP21 ^{*5} , QJ71LP21-25, QJ71LP21S-25, QJ71LP21G, QJ71LP21GE, QJ71BR11, QJ71NT11B
	MODBUS/TCP interface module ^{*9}	QJ71MT91
	MODBUS interface module ^{*9}	QJ71MB91
	FL-net (OPCN-2) interface module ^{*8*9}	QJ71FL71, QJ71FL71-T, QJ71FL71-B2, QJ71FL71-B5, QJ71FL71-F01, QJ71FL71-T-F01, QJ71FL71-B2-F01, QJ71FL71-B5-F01
AS-i master module ^{*2*9}	QJ71AS92	
Intelligent communication module ^{*5*9}	QD51, QD51-R24	
DeviceNet master-slave module ^{*9}	QJ71DN91	
AnyWireASLINK master module ^{*9}	QJ51AW12AL	
Energy measuring module ^{*9}	QE81WH, QE84WH, QE81WH4W, QE83WH4W	
Insulation monitoring module ^{*9}	QE82LG	
Blank cover module	Blank cover	QG60
	Large type blank cover ^{*5*9}	QG69L
	Q series large type blank cover (AnS series size) ^{*5*9}	QG69LS

- *1 MELSECNET/H network modules can be used with the programmable controller CPU, Safety CPU, or C Controller module. When using this module with the RnCPU, Safety CPU, or C Controller module, check the versions of the CPU module and engineering tool used. (📖 User's Manual (Application) for the CPU module used)
However, in a multiple CPU system where the Process CPU is used, they cannot be used even when the programmable controller CPU, the Safety CPU, or the C Controller module is set as the control CPU of them.
- *2 These modules cannot be used with a remote head module.
- *3 These modules cannot be used with a remote head module (in a redundant system).
- *4 This module cannot be used as an interrupt module when a remote head module is used.
- *5 These modules cannot be used with a C Controller module.
- *6 The method for enabling parameters differs depending on the firmware version of the C Controller module. (📖 MELSEC iQ-R C Controller Module User's Manual)
- *7 There are restrictions on the supported CPU modules. (📖 Page 256 Precautions)
- *8 Read the precautions before configuring a C Controller system. (📖 Page 107 When using MELSEC-Q series modules)
- *9 These modules cannot be used with a MELSECWinCPU module.

1.3 System Configuration Specifications

This section describes the overview of the MELSEC iQ-R series system configuration.

CPU module (except the C Controller module and MELSECWinCPU module)

The following table shows the system configuration of when a CPU module is mounted on a CPU slot of a main base unit.^{*1}

Item	Description	
Module mounting position	Slot number 0 to 63	
Maximum number of mountable modules	Single CPU system	64 ^{*2*4*7*8}
	Multiple CPU system	57 to 63 ^{*2*3*4*7*8}
	Redundant system	63
	System using the SIL2 Process CPU	10
	System using the Safety CPU	63 ^{*2*4*7}
Maximum number of extension base units	7 ^{*5}	
Overall extension cable distance	20m ^{*6}	

- *1 When a CPU module is mounted on a CPU slot, a remote head module cannot be mounted.
- *2 Mount modules so that the total number of occupied I/O points of these modules is equal to or less than the number of I/O points of the CPU module used. (MELSEC iQ-R CPU Module User's Manual (Startup))
The number of I/O points of each module to be mounted can be checked on the engineering tool. (GX Works3 Operating Manual)
- *3 Modules can be mounted on the slot number 63 to the slot on the right of the slot on which the rightmost CPU module is mounted. For example, when four CPU modules are mounted on the CPU slot and slot number 0 to 2, the maximum number of mountable modules is 61.
- *4 The number of mountable modules includes the empty slots. Even if the number of I/O points is set to zero for an empty slot, the slot is counted as one module.
- *5 This is the total number of the extension base units, RQ extension base units, and MELSEC-Q series extension base units.
- *6 When a MELSEC-Q series module is used in the system, the overall cable distance is 13.2m.

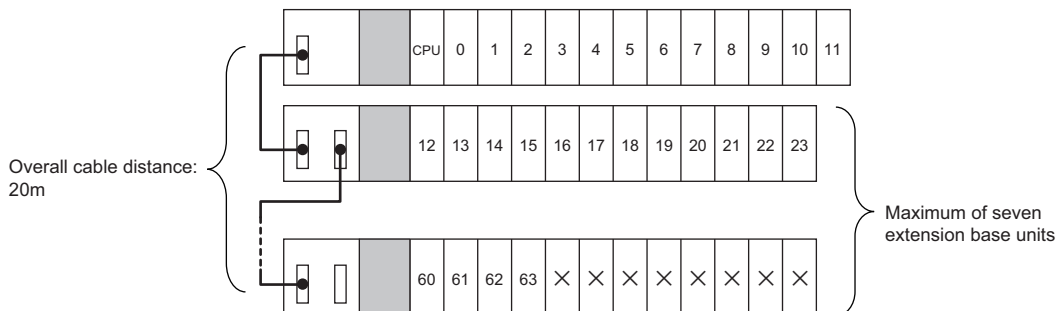

- Shaded areas are for the power supply modules.
- "CPU" is the CPU slot, and the numbers are slot numbers.
- Modules cannot be mounted on the slots marked ×.
- *7 Depending on a module used, mounting of the maximum number of modules may not be possible because of the rated output current of the power supply module used. Configure the system taking the current consumption of each module into consideration.
- *8 The RnENCPU is a module occupies two slots, and therefore the maximum number of mountable modules decreases due to this one more slot occupied.

C Controller module

The following table shows the system configuration of when a C Controller module is mounted on a CPU slot of a main base unit.*1

Item	Description	
Module mounting position	Slot number 1 to 63	
Maximum number of mountable modules	Single CPU system	63*2*3*7
	Multiple CPU system	57 to 62*2*3*4*7
Maximum number of extension base units	7*5	
Overall extension cable distance	20m*6	

- *1 When a C Controller module is mounted on a CPU slot, a remote head module cannot be mounted.
- *2 Mount modules so that the total number of occupied I/O points of these modules is equal to or less than the number of I/O points of the C Controller module used. (📖 MELSEC iQ-R C Controller Module User's Manual)
The number of I/O points of each module to be mounted can be checked on the engineering tool. (📖 CW Configurator Operating Manual)
- *3 The number of mountable modules includes the empty slots. Even if the number of I/O points is set to '0' for an empty slot, the slot is counted as one module.
- *4 Modules can be mounted on the slot number 63 to the slot on the right of the slot on which the rightmost C Controller modules is mounted. For example, when four C Controller modules are mounted on the CPU slot and slot number 1 to 6, the maximum number of mountable modules is 57.
- *5 This is the total number of extension base units, RQ extension base units, and MELSEC-Q series extension base units.
- *6 When a MELSEC-Q series module is used in the system, the overall cable distance is 13.2m.

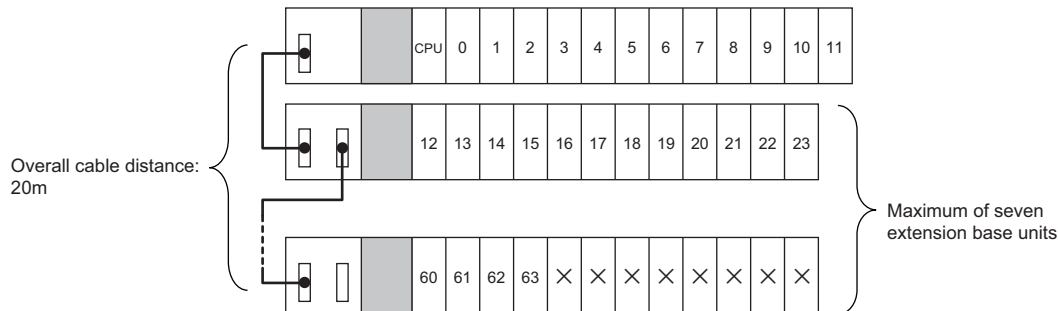

- Shaded areas are for the power supply modules.
 - "CPU" is the CPU slot, and the numbers are slot numbers.
 - Modules cannot be mounted on the slots marked ×.
- *7 Depending on a module used, mounting of the maximum number of modules may not be possible because of the rated output current of the power supply module used. Configure the system taking the current consumption of each module into consideration.

Remote head module

The following table shows the system configuration of when a remote head module is mounted on a CPU slot of a main base unit.^{*1}

Item	Description
Module mounting position	Slot number 0 to 63
Maximum number of mountable modules	64 (When two remote head modules are mounted for a redundant system or a redundant line: 63) ^{*2*3*6*7}
Maximum number of extension base units	7 ^{*4}
Overall extension cable distance	20m ^{*5}

*1 When a remote head module is mounted on a CPU slot, a CPU module cannot be mounted.

*2 Mount modules so that the total number of occupied I/O points of these modules is equal to or less than the number of I/O points of the remote head module used. (📖 MELSEC iQ-R CC-Link IE Field Network Remote Head Module User's Manual (Startup))

The number of I/O points of each module to be mounted can be checked on the engineering tool. (📖 GX Works3 Operating Manual)

*3 The number of mountable modules includes the empty slots. Even if the number of I/O points is set to zero for an empty slot, the slot is counted as one module.

*4 This is the total number of the extension base units, RQ extension base units, and MELSEC-Q series extension base units.

*5 When a MELSEC-Q series module is used in the system, the overall cable distance is 13.2m.

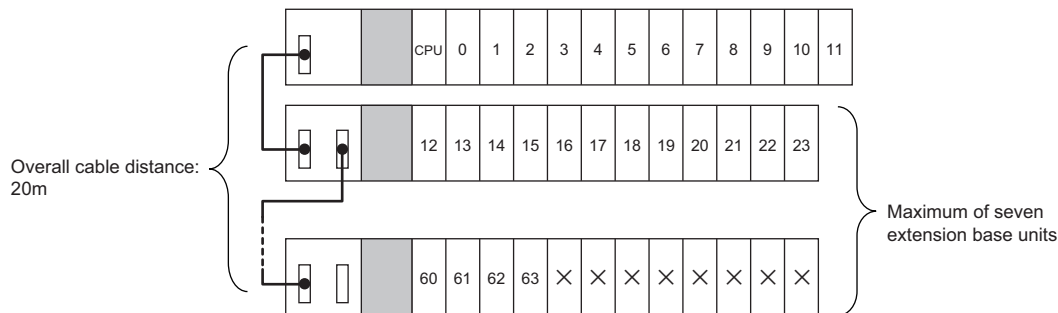

- Shaded areas are for the power supply modules.
- "CPU" is the CPU slot, and the numbers are slot numbers.
- Modules cannot be mounted on the slots marked ×.

*6 Depending on a module used, mounting of the maximum number of modules may not be possible because of the rated output current of the power supply module used. Configure the system taking the current consumption of each module into consideration.

*7 In the configuration in SIL2 mode, if a module that communicates using safety protocol version 2 is mounted, the maximum number of modules set to SIL2 mode Main that can be mounted is 16.

MELSECWinCPU module

The following table shows the system configuration of when a MELSECWinCPU module is mounted on a CPU slot of a main base unit.^{*1}

Item		Description
Module mounting position		Slot number 2 to 63
Maximum number of mountable modules	Single CPU system	62 ^{*2} ×3 ^{*7}
	Multiple CPU system	56 to 61 ^{*2} ×3 ^{*4} ×7
Maximum number of extension base units		7 ^{*5}
Overall extension cable distance		20m ^{*6}

*1 When a MELSECWinCPU module is mounted on a CPU slot, a remote head module cannot be mounted.

*2 Mount modules so that the total number of occupied I/O points of these modules is equal to or less than the number of I/O points of the MELSECWinCPU module used. (📖 MELSEC iQ-R MELSECWinCPU Module User's Manual)

The number of I/O points of each module to be mounted can be checked on the engineering tool. (📖 CW Configurator Operating Manual)

*3 The number of mountable modules includes the empty slots. Even if the number of I/O points is set to '0' for an empty slot, the slot is counted as one module.

*4 Modules can be mounted up to the slot number 63 from the next slot to the right of where the rightmost MELSECWinCPU module is mounted. For example, when a MELSECWinCPU module is mounted on the CPU slot and CPU modules occupying two slots are mounted on the slot number 2 to 7, the maximum number of mountable modules is 56.

*5 This is the total number of extension base units, RQ extension base units, and MELSEC-Q series extension base units.

*6 When a MELSEC-Q series module is used in the system, the overall cable distance is 13.2m.

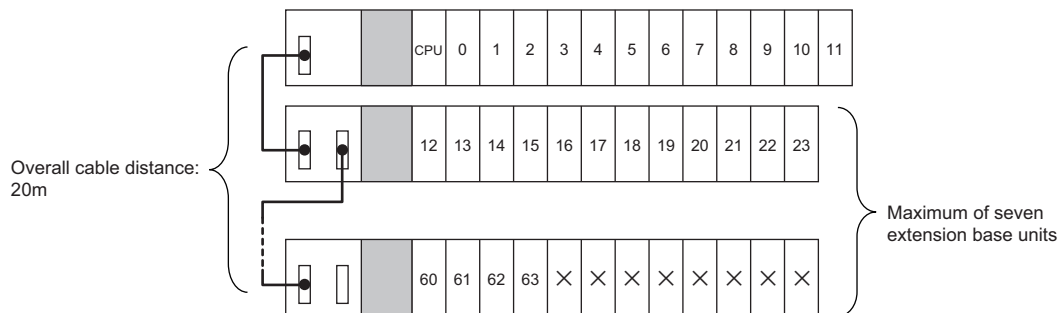

- Shaded areas are for the power supply modules.
- "CPU" is the CPU slot, and the numbers are slot numbers.
- Modules cannot be mounted on the slots marked ×.

*7 Depending on a module used, mounting of the maximum number of modules may not be possible because of the rated output current of the power supply module used. Configure the system taking the current consumption of each module into consideration.

Modules having restrictions on the number of mountable modules

This section describes modules having restrictions on the number of mountable modules.

MELSEC iQ-R series modules

■CPU module (except the C Controller module and MELSECWinCPU module)

The following table shows the restrictions on the number of mountable modules of when a CPU module is mounted on a CPU slot of a main base unit.

Module	Model	Maximum number of mountable modules			
		Single CPU system ^{*16}	Multiple CPU system ^{*16}	Redundant system	System using the SIL2 Process CPU
CC-Link IE Controller Network-equipped module	<ul style="list-style-type: none"> • RJ71GP21-SX • RJ71GP21S-SX • RJ71EN71^{*3} 	8 ^{*4}	32 (One CPU module can control eight modules.)	8	8 ^{*8}
CC-Link IE TSN master/local module	• RJ71GN11-T2	8 ^{*1*4*10}	32 (One CPU module can control eight modules.) ^{*1*4*11}	—	—
	• RJ71GN11-SX	8 ^{*1*4*10}			
	• RJ71GN11-EIP	8 ^{*4*10}			
Motion module	<ul style="list-style-type: none"> • RD78G4 • RD78G8 • RD78G16 • RD78G32 • RD78G64 • RD78GHV • RD78GHW 	8 ^{*1*4*10}	32 (One CPU module can control eight modules.) ^{*1}	8	8 ^{*7*9}
	CC-Link IE Field Network-equipped master/local module				
CC-Link system master/local module	• RJ61BT11	8 ^{*1}	32 (One CPU module can control eight modules.) ^{*1}	8	8 ^{*7}
MES interface module ^{*5}	<ul style="list-style-type: none"> • RD81MES96 • RD81MES96N 	4 ^{*17}	16 (One CPU module can control four modules.) ^{*17}	—	—
High speed data logger module ^{*5}	• RD81DL96	4	16 (One CPU module can control four modules.)	4	—
C intelligent function module ^{*5}	<ul style="list-style-type: none"> • RD55UP06-V • RD55UP12-V 	4 ^{*18}	16 (One CPU module can control four modules.) ^{*18}	11	10
OPC UA server module ^{*5}	• RD81OPC96	4 ^{*19}	16 (One CPU module can control four modules.) ^{*19}	—	—
Recorder module ^{*15}	• RD81RC96	1	4 (One CPU module can control one module.)	—	—
Camera recorder module ^{*15}	• RD81RC96-CA	4	16 (One CPU module can control four modules.)	—	—
High speed data communication module ^{*5}	• RD81DC96	4	16 (One CPU module can control four modules.)	—	—
Simple motion module	<ul style="list-style-type: none"> • RD77GF4 • RD77GF8 • RD77GF16 • RD77GF32 	8 ^{*4*6}	8 (Only CPU No.1 can control modules.) ^{*6}	—	—
MELSECNET/H network module ^{*14}	• RJ71LP21-25	4 ^{*12}	4 (One CPU module can control four modules.) ^{*13}	4 ^{*12}	—
	• RJ71BR11			—	—

- *1 There is no restriction on the number of mountable modules when parameters are set using the dedicated instruction after "Program" in "Module Parameter" is selected. Note that this does not apply to a safety station. Only the module where "Parameter Editor" is set can be set for the safety station.
- *2 There are the restrictions when the CC-Link IE Field Network function is used. Note that the model cannot be used with the Process CPU (redundant mode), SIL2 Process CPU, or Safety CPU.
- *3 There are the restrictions when the CC-Link IE Controller Network function is used. Note that the model cannot be used with the Process CPU (redundant mode), SIL2 Process CPU, or Safety CPU.
- *4 This number includes the RnENCPU (network part). When the CPU module used is the RnENCPU and the RnENCPU (network part) is used for the CC-Link IE Field Network function or the CC-Link IE Controller Network function, the maximum number of mountable modules equipped with the used network function is decreased by 1. For instance, when the RnENCPU (network part) is used for the CC-Link IE Field Network function, the maximum number of mountable CC-Link IE Field Network-equipped master/local modules is decreased by 1. In this case, the maximum number of mountable CC-Link IE Controller Network-equipped modules remains the same.
- *5 For one CPU module, the number of mountable modules that use the sequence scan synchronization sampling function should be a combination of RD81MES96, RD81MES96N, RD81DL96, RD55UP06-V, RD55UP12-V, RD81OPC96, and RD81DC96 with the maximum module count to be four. For the R00CPU, R01CPU, or R02CPU is used, the number of mountable modules that use the function should be a combination of those modules with the maximum module count to be two. Refer to the manuals for the CPU module and each module that uses the sequence scan synchronization sampling function, because the sequence scan synchronization sampling function has other restrictions in addition to the restriction on the number of modules.
- *6 The total number of CC-Link IE Field Network-equipped master/local modules and simple motion modules must be eight modules or less.
- *7 Setting with dedicated instructions is not available.
- *8 To mount the maximum number of the RJ71GP21(S)-SX allowed, use the R64P for the power supply module. Since the rated output current of the R64P is 9A, up to six of the RJ71GP21(S)-SX can be mounted.
- *9 To mount the maximum number of the RJ71GF11-T2 allowed, use the R64P for the power supply module. Since the rated output current of the R64P is 9A, up to seven of the RJ71GF11-T2 can be mounted.
- *10 The total number of CC-Link IE TSN master/local modules, Motion modules, and CC-Link IE Field Network-equipped master/local modules must be eight modules or less.
- *11 The total number of CC-Link IE TSN master/local modules, Motion modules, and CC-Link IE Field Network-equipped master/local modules must be 32 modules or less.
- *12 The total number of mountable CC-Link IE Controller Network-equipped modules and MELSECNET/H network modules is eight.
- *13 The total number of mountable CC-Link IE Controller Network-equipped modules and MELSECNET/H network modules is 32.
- *14 The CPU module that controls a MELSEC-Q series MELSECNET/H network module mounted on the RQ extension base unit cannot control the MELSEC iQ-R series MELSECNET/H network module.
- *15 There are restrictions on the firmware version and production information of the CPU module that controls the recorder modules. (📖 MELSEC iQ-R CPU Module User's Manual (Application))
- *16 The CPU modules are the programmable controller CPU, Process CPU (process mode), and Safety CPU.
- *17 A restriction when using high-speed access
- *18 A restriction when using data sampling in sequence scan
- *19 A restriction when using high-speed sampling

■C Controller module

The following table shows the restrictions on the number of mountable modules of when a C Controller module is mounted on a CPU slot of a main base unit.

Module	Model	Maximum number of mountable modules		
		Single CPU system	Multiple CPU system	Redundant system
CC-Link IE Controller Network-equipped module	<ul style="list-style-type: none"> • RJ71GP21-SX • RJ71GP21S-SX • RJ71EN71*2 	8*1	32 (One CPU module can control eight modules.)*3	—
CC-Link IE TSN master/local module	<ul style="list-style-type: none"> • RJ71GN11-T2*4 • RJ71GN11-SX 	8*5	32 (One CPU module can control eight modules.)*6	—
Motion module	<ul style="list-style-type: none"> • RD78G4 • RD78G8 • RD78G16 • RD78G32 • RD78G64 • RD78GHV • RD78GHW 	8*5	32 (One CPU module can control eight modules.)*6	—
CC-Link IE Field Network-equipped master/local module*4	<ul style="list-style-type: none"> • RJ71GF11-T2 • RJ71EN71*7 	8*5	32 (One CPU module can control eight modules.)*6	—
CC-Link system master/local module	<ul style="list-style-type: none"> • RJ61BT11 	8	32 (One CPU module can control eight modules.)*8	—
High speed data logger module	<ul style="list-style-type: none"> • RD81DL96 	4	16 (One CPU module can control four modules.)	—
High speed data communication module	<ul style="list-style-type: none"> • RD81DC96 	4	16 (One CPU module can control four modules.)	—
Simple motion module*9	<ul style="list-style-type: none"> • RD77GF4 • RD77GF8 • RD77GF16 • RD77GF32 	8	8 (Only CPU No.1 can control modules.)	—

*1 The total number of mountable CC-Link IE Controller Network-equipped modules (when the CC-Link IE Controller Network function is used) and MELSECNET/H network modules is eight. The number of mountable CC-Link IE Controller Network-equipped modules (when the CC-Link IE Controller Network function is used) will decrease when one or more MELSECNET/H network modules are mounted.

*2 There are the restrictions when the CC-Link IE Controller Network function is used.

*3 The total number of mountable CC-Link IE Controller Network-equipped modules (when the CC-Link IE Controller Network function is used) and MELSECNET/H network modules is 32. The number of mountable CC-Link IE Controller Network-equipped modules (when the CC-Link IE Controller Network function is used) will decrease when one or more MELSECNET/H network modules are mounted.

*4 There is no restriction on the number of mountable modules when parameters are set using the dedicated instruction after "Program" in "Module Parameter" is selected.

*5 In the single CPU system configuration, the total number of CC-Link IE TSN master/local modules, Motion modules, and CC-Link IE Field Network-equipped master/local modules must be eight modules or less.

*6 In the multiple CPU system configuration, the total number of CC-Link IE TSN master/local modules, Motion modules, and CC-Link IE Field Network-equipped master/local modules must be 32 modules or less.

*7 There are the restrictions when the CC-Link IE Field Network function is used.

*8 There is no restriction on the number of mountable modules when parameters are set using the dedicated instruction after "Program" in "Module Parameter" is selected. Note that this does not apply when a C Controller module control modules.

*9 The total number of CC-Link IE Field Network-equipped master/local modules and simple motion modules must be eight modules or less.

■Remote head module

The following table shows the restrictions on the number of mountable modules of when a remote head module is mounted on a CPU slot of a main base unit.

Module	Model	Maximum number of mountable modules
CC-Link system master/local module	<ul style="list-style-type: none"> • RJ61BT11 	8 (same as in a redundant system configuration)

■MELSECWinCPU module

The following table shows the restrictions on the number of mountable modules of when a MELSECWinCPU module is mounted on a CPU slot of a main base unit.

Module	Model	Maximum number of mountable modules	
		Single CPU system	Multiple CPU system
CC-Link IE Controller Network-equipped module	<ul style="list-style-type: none"> • RJ71GP21-SX • RJ71GP21S-SX 	8	32 (One CPU module can control eight modules.)
CC-Link IE TSN master/local module	<ul style="list-style-type: none"> • RJ71GN11-T2 	8	32 (One CPU module can control eight modules.)
CC-Link system master/local module	<ul style="list-style-type: none"> • RJ61BT11 	8	32 (One CPU module can control eight modules.)

MELSEC-Q series modules

■CPU module (except the C Controller module and MELSECWinCPU module)

The following table shows the restrictions on the number of mountable modules of when a CPU module is mounted on a CPU slot of a main base unit.

Module	Model	Maximum number of mountable modules	
		Single CPU system	Multiple CPU system
Interrupt module* ¹	• QI60	1	4 (One CPU module can control one module.)
Input module* ^{1,2}	• QX40H • QX70H • QX80H • QX90H	1	4 (One CPU module can control one module.)
MELSECNET/H network module* ⁵	• QJ71LP21 • QJ71LP21-25 • QJ71LP21S-25 • QJ71LP21G, QJ71LP21GE • QJ71BR11 • QJ71NT11B	4* ³	4* ⁴ (One CPU module can control four modules.)

*1 There are the restrictions when parameters are not set in "I/O Assignment Setting" of the [I/O Assignment] tab on the "System Parameter" window. There is no restriction when parameters are set in "I/O Assignment Setting".

*2 There are the restrictions when the input module is shifted to an interrupt module by turning off the function selection switch (SW2).

*3 The total number of mountable CC-Link IE Controller Network-equipped modules (when the CC-Link IE Controller Network function is used) and MELSECNET/H network modules is eight. The number of mountable MELSECNET/H network modules will decrease when five or more CC-Link IE Controller Network-equipped modules (when the CC-Link IE Controller Network function is used) are mounted.

*4 The total number of mountable CC-Link IE Controller Network-equipped modules (when the CC-Link IE Controller Network function is used) and MELSECNET/H network modules is 32. The number of mountable MELSECNET/H network modules will decrease when 28 or more CC-Link IE Controller Network-equipped modules (when the CC-Link IE Controller Network function is used) are mounted.

*5 The CPU module that controls a MELSEC iQ-R series MELSECNET/H network module cannot control the MELSEC-Q series MELSECNET/H network module mounted on the RQ extension base unit.

■C Controller module

The following table shows the restrictions on the number of mountable modules of when a C Controller module is mounted on a CPU slot of a main base unit.

Module	Model	Maximum number of mountable modules	
		Single CPU system	Multiple CPU system
Interrupt module* ¹	• QI60	1	4 (One CPU module can control one module.)
MELSECNET/H network module	• QJ71LP21-25 • QJ71LP21S-25 • QJ71LP21G, QJ71LP21GE • QJ71BR11 • QJ71NT11B	4* ²	4 (One CPU module can control four modules.)* ³

*1 When setting an interrupt pointer to be used with CW Configurator, there is no restriction on the number of mountable modules. (Up to 64 modules can be mounted.)

*2 The total number of mountable CC-Link IE Controller Network-equipped modules (when the CC-Link IE Controller Network function is used) and MELSECNET/H network modules is eight. The number of mountable MELSECNET/H network modules will decrease when five or more CC-Link IE Controller Network-equipped modules (when the CC-Link IE Controller Network function is used) are mounted.

*3 The total number of mountable CC-Link IE Controller Network-equipped modules (when the CC-Link IE Controller Network function is used) and MELSECNET/H network modules is 32. The number of mountable MELSECNET/H network modules will decrease when 28 or more CC-Link IE Controller Network-equipped modules (when the CC-Link IE Controller Network function is used) are mounted.

Base unit combination

The following tables show which base unit combinations are possible.

○: Combination possible, ×: Combination not possible

Main base unit	Extension base unit						
	R6□B	RQ6□B ^{*2}	R6□B-HT	R6□RB	R6□RB-HT	R6□WRB	R6□WRB-HT
R3□B	○	○	○ ^{*1}	○	○ ^{*1}	○ ^{*3}	○ ^{*1*3}
R3□SB	×	×	×	×	×	×	×
R3□B-HT	○ ^{*1}	○ ^{*1}	○	○ ^{*1}	○	○ ^{*1*3}	○ ^{*3}
R3□RB	○	○	○ ^{*1}	○	○ ^{*1}	○ ^{*3}	○ ^{*1*3}
R3□RB-HT	○ ^{*1}	○ ^{*1}	○	○ ^{*1}	○	○ ^{*1*3}	○ ^{*3}

*1 If the combination contains base units other than the extended temperature range base unit, use in an operating ambient temperature of 0 to 55°C.

*2 Only the MELSEC-Q series extension base unit can be connected to the lower level of an RQ extension base unit. (👉 Page 171 When MELSEC-Q series modules are used)

*3 For the combination of extension base units, refer to the following.

👉 Page 104 Precautions for redundant system with redundant extension base unit

Point

Only use the redundant power supply base unit for redundant configuration of power supply modules in the entire system. If another type of base unit is used together and an error occurs in its power supply, the entire system stops.

Combinations of a base unit and a power supply module

The following table shows which combinations of a base unit and a power supply module are possible. In addition, check combinations with CPU modules. (👉 Page 74 Lists of Configuration Devices)

○: Combination possible, ×: Combination not possible

Base unit		Power supply module		
		R6□P	R61SP	R6□RP
Main base unit	R3□B	○	×	○
	R3□SB	×	○	×
	R3□B-HT	○	×	○
	R3□RB	×	×	○
	R3□RB-HT	×	×	○
Extension base unit	R6□B	○	×	○
	RQ6□B	×	×	×
	R6□B-HT	○	×	○
	R6□RB	×	×	○
	R6□RB-HT	×	×	○
	R6□WRB	×	×	○
	R6□WRB-HT	×	×	○

Combinations of CPU modules in a multiple CPU system

The CPU modules that can be used in the multiple CPU system differ depending on what type of CPU module is mounted as CPU No.1.

The following table summarizes the possible combination of CPU modules and the number of mountable modules in the multiple CPU system.

The CPU modules mounted as CPU No.2 or later are described as follows.

- Rn: RnCPU
- RnEN: RnENCPU
- RnP(P): Process CPU (process mode)
- RnMT: Motion CPU
- RnNC: NCCPU
- RnRT: Robot CPU
- RnC: C Controller module
- RnSF: Safety CPU
- RnW: MELSECWinCPU module

CPU module mounted as CPU No.1	Number of CPU modules that can be mounted as CPU No.2 and later								
	Rn	RnEN ^{*6}	RnP(P)	RnMT ^{*13}	RnNC	RnRT	RnC ^{*5}	RnSF	RnW
RnCPU	0 to 3	0 to 1 ^{*2,7}	0 to 3 ^{*1}	0 to 3	0 to 3	0 to 3 ^{*9}	0 to 3 ^{*8}	0 to 1 ^{*2,3,7}	0 to 1 ^{*14}
RnENCPU ^{*6}	0	0	0	0 to 3 ^{*6}	0	0	0	0	0
Process CPU (process mode)	0 to 3 ^{*1,4}	0 to 1 ^{*2,7}	0 to 3	0 to 3 ^{*1,4}	0	0	0 to 3 ^{*8}	0 to 1 ^{*2,7}	0 to 1 ^{*14}
Safety CPU ^{*10}	0 to 3	0 to 1 ^{*7}	0 to 3 ^{*1}	0 to 3 ^{*11}	0 to 3	0 to 3	0 to 3 ^{*8,12}	0	0 to 1 ^{*14}
C Controller module ^{*5}	0 to 3 ^{*8}	0 to 1 ^{*2,7}	0 to 3	0 to 3	0	0	0 to 3 ^{*8}	0 to 1 ^{*2,7}	0 to 1 ^{*14}
MELSECWinCPU module	0 to 3 ^{*1,4}	0 to 1 ^{*2,7}	0 to 3	0 to 3	0	0	0 to 3 ^{*8}	0 to 1 ^{*2,7}	0

- *1 Under the multiple CPU system configuration, online module change is not permitted.
- *2 The Safety CPU with firmware version "13" or earlier or the RnENCPU must be mounted at the rightmost position of the block of CPU modules. For the Safety CPU with firmware version "14" or later, there are no restrictions on the mounting position. However, CPU modules cannot be mounted to the right of the safety function module.
- *3 If the following function is executed in the system where the Safety CPU and the RnCPU with a firmware version "11" or earlier are used, the model of the base unit cannot be displayed.
 - System monitor
 - [Online] ⇒ [Read Module Configuration from PLC] when the "Module Configuration" window is displayed
 - "Read Mounting Status" of the [I/O Assignment] tab on the "System Parameter" window
- *4 If a multiple CPU system is configured in these combinations and "Enable" is set in "Direct change setting" of "CPU Parameter" for the Process CPU No.1 (process mode), an error occurs. To prevent the error, set "Disable" in "Direct change setting".
- *5 When the C Controller module is used in combination with the Process CPU, use the C Controller module with firmware version "04" or later.
- *6 When configuring a multiple CPU system, use the RnENCPU with firmware version "25" or later, the Motion CPU with firmware version "10" or later, and the engineering tool with version "1.032J" or later. ( Page 100 Precautions for the case where an RnENCPU is set as CPU No.1)
- *7 The Safety CPU with firmware version "13" or earlier and the RnENCPU cannot be used together. The Safety CPU with firmware version "14" or later can be used with the RnENCPU. When the two devices are used together, the RnENCPU must be mounted at the rightmost position of the block of CPU modules.
- *8 The C Controller module cannot be used with the R00CPU, R01CPU, or R02CPU.
- *9 The robot CPU cannot be used with any CPU modules other than the RnCPU, Motion CPU, and NCCPU.
- *10 When the Safety CPU is set as CPU No.1, use the Safety CPU and safety function module with firmware versions "14" or later.
- *11 In the Safety CPU and multiple CPU system, use the MT Works2 version "1.155M" or later when using the fixed scan communication function.
- *12 The system parameter utilization function is not available for the import of system parameters of the Safety CPU to the C Controller module.
- *13 If a multiple CPU system is under abnormal conditions (for example, a self-diagnostic error, such as a CPU module configuration error or a parameter error, has occurred), communications over the multiple CPU system may not be performed. In this case, use the PERIPHERAL I/F of the Motion CPU to read/write from/to the Motion CPU.
- *14 The MELSECWinCPU module cannot be used with the R00CPU, R01CPU, or R02CPU.



The Process CPU (redundant mode) or the SIL2 Process CPU cannot be used in a multiple CPU system.

1.4 Applicable Software

The following table lists software that can be used for the MELSEC iQ-R series system. (Manual for each software used)
When using a C Controller module, refer to the following.

📖 MELSEC iQ-R C Controller Module User's Manual

When using a MELSECWinCPU module, refer to the following.

📖 MELSEC iQ-R MELSECWinCPU Module User's Manual

Item	Function and application
iQ Works Version 2	A package software integrated the various software such as a programmable controller, motion controller, and GOT
GX Works3	Software for a system design, programming, debug, and maintenance of a programmable controller
CPU Module Logging Configuration Tool	Software for data logging setting and maintenance
MT Works2	Software for a system design, programming, debug, and maintenance of the Motion CPU

1.5 Precautions for System Configuration

This section describes precautions for configuring a system.

Precautions when using the extended temperature range base unit

Pay attention to the following if using the extended temperature range base unit to construct a system compatible with operating ambient temperature of 0 to 60°C.

- Only use extended temperature range base units in a system. If using a combination with base units other than the extended temperature range base unit, use the system in an operating ambient temperature of 0 to 55°C. (📖 Page 95 Base unit combination)
- All modules mounted on the extended temperature range base unit offer the same performance as that for an operating ambient temperature of 0 to 55°C, and can be used in an operating ambient temperature of 0 to 60°C.
- Select external devices installed in the same control panel that are compatible with an operating ambient temperature of 0 to 60°C.

Consideration for internal current consumption

Configure the system so that the internal current consumption of the entire system will be less than the rated output current of the power supply module.

The internal current consumption can be checked by using the engineering tool as follows.

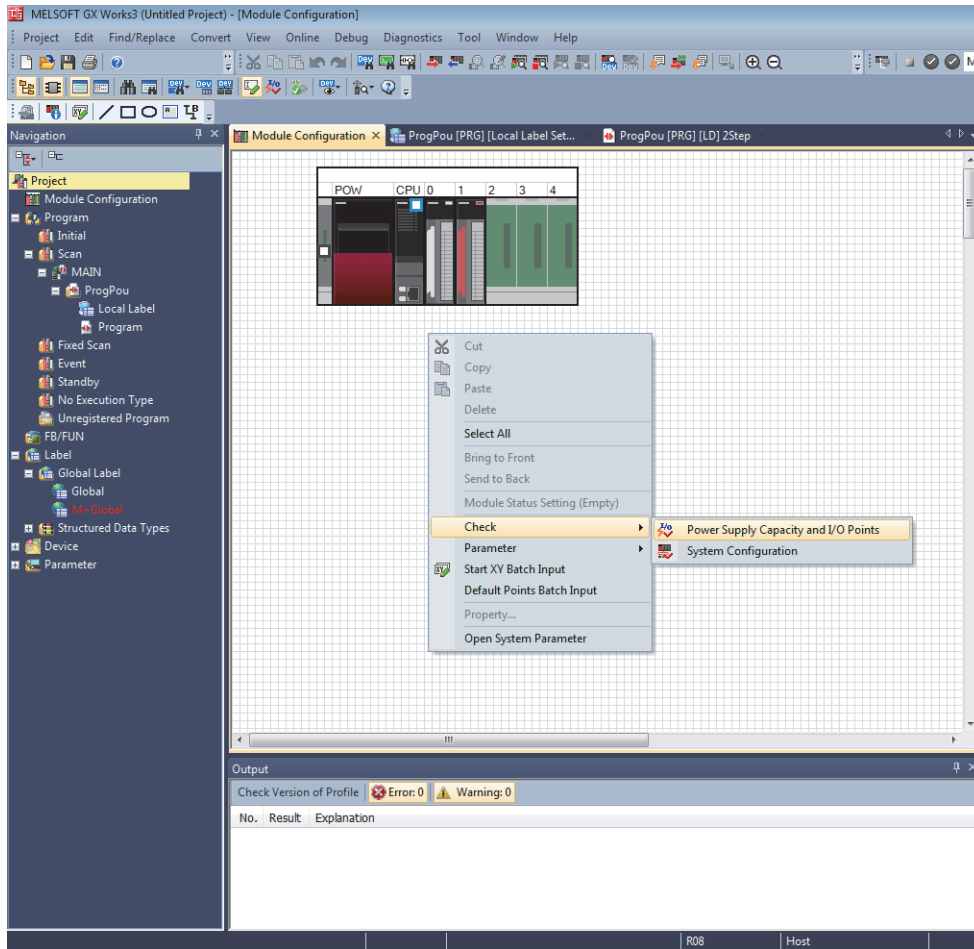

The following window shows the check result.

Result of Power Supply Capacity and I/O Points Check						
Base/Cable	Slot	Model Name	Consumption Current	Total Consumption Current	Total Drop Voltage	Total I/O Points
R35B	-	R35B	0.58A	1.81A / 6.5A		80 Point / 4096 Point
	[Power Supply]	R61P	-			
	[CPU]	R04CPU	0.67A			
	[0]	RX10	0.11A			
	[1]	RY10R2	0.45A			

Precautions for multiple CPU system configuration

This section describes the precautions when configuring a multiple CPU system.

Precautions for access via the network module

In a multiple CPU system, CPU modules cannot access their target CPU module by operating the engineering tool or using dedicated instructions when:

- The target CPU module is not compatible with the network module on the communication path.
- The CPU module requesting the access is not compatible with the network module on the communication path.

Ex.

The following example shows whether each target CPU module is accessible when the network module on the communication path is the CC-Link IE TSN master/local module.

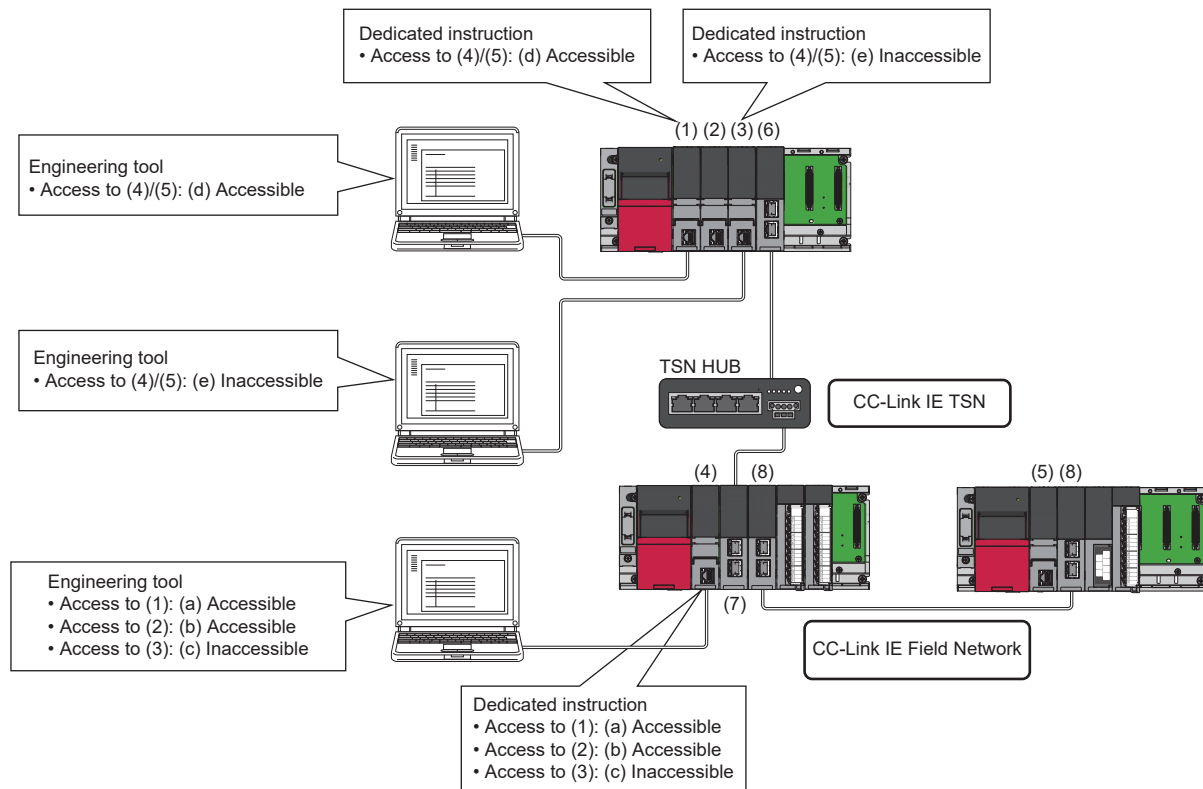

- (1), (2), (4): CPU modules compatible with the CC-Link IE TSN master/local module
 (3), (5): CPU modules not compatible with the CC-Link IE TSN master/local module
 (6): CC-Link IE TSN master/local module controlled by the CPU No.1
 (7): CC-Link IE TSN master/local module
 (8): CC-Link IE Field Network master/local modules

Access to

(a)	The control CPU of the CC-Link IE TSN master/local module
(b)	Another CPU module that is compatible with the CC-Link IE TSN master/local module ^{*1}
(c)	Another CPU module that is not compatible with the CC-Link IE TSN master/local module ^{*1}
(d)	The CPU modules in other stations (from the CPU module that is compatible with the CC-Link IE TSN master/local module ^{*1} via network modules)
(e)	The CPU modules in other stations (from the CPU module that is not compatible with the CC-Link IE TSN master/local module ^{*1} via network modules)

^{*1} For the firmware version of the CPU module that is compatible with the CC-Link IE TSN master/local module, refer to the following.

📖 MELSEC iQ-R CPU Module User's Manual (Application)

Precautions for the case where an RnENCPU is set as CPU No.1

When an RnENCPU is set as CPU No.1, set the module configuration diagram and the I/O assignment as shown below.

■Module configuration diagram settings

Place the RnENCPU (network part)^{*1} on the right of the Motion CPU at the rightmost position.

*1 Set the RnENCPU as "_RJ71EN71(○○)" in GX Works3. ○○ in brackets indicates an abbreviation of network type.

For details, refer to the following.

📖 MELSEC iQ-R Ethernet/CC-Link IE User's Manual (Startup)

• Configuration of two modules (CPU No.1: RnENCPU, No.2: Motion CPU)

• Actual system



• Module configuration diagram

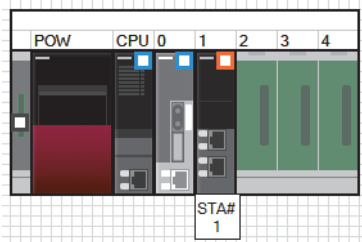

1. Mount the RnENCPU (CPU part) on the CPU slot.
2. Mount the Motion CPU on the slot 0.
3. Mount the RnENCPU (network part) on the slot 1.

• Configuration of three modules (CPU No.1: RnENCPU, No.2 and No.3: Motion CPU)

• Actual system



• Module configuration diagram

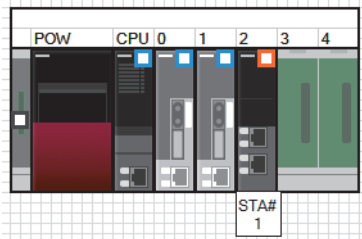

1. Mount the RnENCPU (CPU part) on the CPU slot.
2. Mount the Motion CPUs on the slot 0 and slot 1.
3. Mount the RnENCPU (network part) on the slot 2.

- Configuration of four modules (CPU No.1: RnENCPU, No.2 to No.4: Motion CPU)
- Actual system



- Module configuration diagram

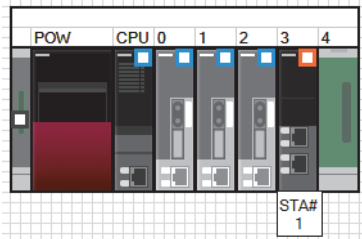

1. Mount the RnENCPU (CPU part) on the CPU slot.
2. Mount the Motion CPUs on the slot 0 to slot 2.
3. Mount the RnENCPU (network part) on the slot 3.

Point

When "Read Module Configuration from PLC" is performed while parameters are not configured, module configuration is read according to the actual system. In that case, change the position of the RnENCPU (network part) to the right of the Motion CPU at the rightmost position as described in this manual. After setting parameters, the module configuration diagram keeps the setting of the parameters even though "Read Module Configuration from PLC" is performed. (Module configuration that differs from actual system is displayed.)

I/O assignment settings

Set the RnENCPU (network part)^{*1} just below the Motion CPU on the last slot.

- *1 Set the RnENCPU as "_RJ71EN71(○○)" in GX Works3. ○○ in brackets indicates an abbreviation of network type. For details, refer to the following.

MELSEC iQ-R Ethernet/CC-Link IE User's Manual (Startup)

- Configuration of two modules (CPU No.1: RnENCPU, No.2: Motion CPU)
- Actual system



- I/O assignment setting

Slot	Module Name	Module Status Setting	Points	Start XY	Control PLC Settings
Base					
CPU	R04ENCPU(Host Station)			3E00	
CPU	R16MTCPU	No Setting		3E10	
1(*-1)	_RJ71EN71(COIEF)	No Setting	32 Points	0000	PLC No. 1

1. Set the Motion CPU on the CPU slot.
2. Set the RnENCPU (network part) on the slot 1.

- Configuration of three modules (CPU No.1: RnENCPU, No.2 and No.3: Motion CPU)
- Actual system



- I/O assignment setting

Slot	Module Name	Module Status Setting	Points	Start XY	Control PLC Settings
Base					
CPU	R04ENCPU(Host Station)			3E00	
CPU	R16MTCPU	No Setting		3E10	
CPU	R16MTCPU	No Setting		3E20	
2(*-2)	_RJ71EN71(COIEF)	No Setting	32 Points	0000	PLC No. 1

1. Set the Motion CPUs (CPU No.2 and No.3) on the CPU slots.
2. Set the RnENCPU (network part) on the slot 2.

- Configuration of four modules (CPU No.1: RnENCPU, No.2 to No.4: Motion CPU)
- Actual system



• I/O assignment setting

Slot	Module Name	Module Status Setting	Points	Start XY	Control PLC Settings
Base					
CPU	R04ENCPU(Host Station)			3E00	
CPU	R16MTCPU	No Setting		3E10	
CPU	R16MTCPU	No Setting		3E20	
CPU	R16MTCPU	No Setting		3E30	
3(←3)	_RJ71EN71(CCEIF)	No Setting	32 Points	0000	PLC No. 1

1. Set the Motion CPUs (CPU No.2 to No.4) on the CPU slots.
2. Set the RnENCPU (network part) on the slot 3.

Point

When "Read Mounting Status" is performed while parameters are not configured, I/O assignment setting is read according to the actual system. In that case, change the position of the RnENCPU (network part) to just below the Motion CPU on the last slot as described in this manual. After setting parameters, the I/O assignment keeps the setting of the parameters even though "Read Mounting Status" is performed. (I/O assignment that differs from actual system is displayed.)

■ Display in the system monitor

The system monitor displays the RnENCPU (network part) placed on the right of the Motion CPU at the rightmost position in the same way as the module configuration window.

- Actual system



- System monitor

Operation Status	No. 1	No. 2	No. 3	No. 4
	STOP	STOP	-	-
Power Supply	-	3E00	I/O0	I/O1
Start I/O No.	-	3E00	3E10	0000
Points	-	-	32 Point	16 Point
I/O2	I/O3	I/O4		
0020	0030	0040		
Module Name	R62P	R04ENCPU	R32MTCPU	_R171E N71 (CCIEF)
Error Status	-	-	-	-
Module Configuration				
Control CPU	-	-	No. 1	-

Point

When the system monitor window is opened while parameters are not configured, module configuration is displayed according to the actual system. The same module configuration as that of the module configuration window is displayed when the system monitor window is opened after setting parameters. (Module configuration that differs from actual system is displayed.)

When mounting a MELSECWinCPU module as CPU No.2 or later

- When resetting the bus master CPU (CPU No.1), Windows in a MELSECWinCPU module is not restarted. To restart the Windows, restart it forcibly or alternatively restart it from the Windows start menu, etc.
- When a major error occurs, a MELSECWinCPU module may not be restarted by resetting the bus master CPU (CPU No.1). If the MELSECWinCPU module does not operate normally after the reset, power off and on the entire system.
- Do not reset the bus master CPU (CPU No.1) consecutively. Doing so may result in a MELSECWinCPU module not operating normally. If the module does not operate normally after resetting the bus master CPU (CPU No.1), power off and on the entire system.

Precautions for redundant system with redundant extension base unit

This section describes the precautions for the redundant system with redundant extension base unit.

Extension base unit for the extension level 1

Always use the redundant extension base unit in the extension level 1.

Extension base unit for the extension levels 2 to 7

- When extension cable redundancy is required, use the redundant extension base units in the extension levels 2 to 7.
- When extension cable redundancy is not required, use other types of extension base units than the redundant extension base unit in the extension levels 2 to 7. Note that the RQ extension base unit cannot be used.

Point

In a system where extension cables are not redundant, using the redundant power supply extension base unit for extension levels 2 to 7 is recommended. Although other types of extension base units can be used, if an error occurs in a power supply module on an extension base unit where the power supply is not redundant, a stop error occurs in the CPU module of both systems and control of the entire system cannot be maintained.

Mountable power supply modules

For the power supply modules that can be mounted on the extension base units in a redundant system with redundant extension base unit, refer to the following.

 Page 95 Combinations of a base unit and a power supply module

Replacement and addition of extension cables

- The extension cable between the main base unit and the extension base unit cannot be replaced during system operation. However, the extension cable between the main base unit of the standby system and the extension level 1 can be replaced or added while the control system is powered off.
- When extension cables are redundant, an extension cable can be replaced or added for the inactive side connector (the connector where ACTIVE LED is off) of the redundant extension base unit. ( MELSEC iQ-R CPU Module User's Manual (Application) (Replacement/Addition of an Extension Cable (Online)))
- When extension cables are not redundant, extension cables between extension base units cannot be replaced or added during system operation.

Overall extension cable distance

- Keep the overall cable distance within 20m in total length of extension cables.
- Keep each cable distance between two base units up to 10m.
- The length of the cables (two extension cables between the redundant extension base unit and two main base units, and those between two redundant extension base units) does not need to be the same. When using varying lengths of cables, use the longer cable to determine the cable distance.

Communications between the CPU module and devices

This section describes the precautions when the following devices communicate with the CPU module in a redundant system via a module on an extension base unit.

1

■When the engineering tool communicates via a module on an extension base unit

- When "Not Specified" is selected for "Specify Redundant CPU" "Specify Redundant CPU" in the "Specify Connection Destination" window, the engineering tool accesses the CPU module of the control system. In the case that the CPU module of system A is the control system, the engineering tool can communicate with the CPU module only when "System A", "Control System", or "Not Specified" is selected. In the case that the CPU module of system A is the standby system, the engineering tool can communicate with the CPU module only when "System A" or "Standby System" is selected.
- In the case where the engineering tool accesses the CPU module in a redundant system via a module on an extension base unit, there are restrictions on the executable functions of the engineering tool depending on the connection destination settings. For details, refer to the following.

 "Precautions for Communications with CPU Module in Redundant System via Module on Extension Base Unit" in the MELSEC iQ-R CPU Module User's Manual (Application)

- A timeout may occur while the systems are being switched. In this case, retry the access or use other communication paths.

■When a device communicates via a module on an extension base unit using SLMP

- Request destination module I/O numbers that can be specified differ depending on the command. ( SLMP Reference Manual)
- A timeout may occur while the systems are being switched. In this case, retry the access or use other communication paths.

■When the FTP server function is used

When the FTP server function of the Ethernet interface module with built-in CC-Link IE mounted on an extension base unit is used, FTP commands that access the CPU module cannot be executed. If executed, an error occurs.

Precautions for C Controller system configuration

Pay attention to the following when configuring a C Controller system by using a C Controller module.

Startup time of a C Controller module

The startup time of a C Controller module may vary depending on the firmware version.

To make a system program run on the startup of a C Controller module, configure an interlock using special relay and special register areas.

Running a system program without an interlock may damage machines or cause accidents due to changes in module behavior caused by the difference in firmware versions resulting from a newly purchased or replaced module, or by the changes in the firmware version after a firmware update.

For details on the special relay or special register areas, refer to the following.

 MELSEC iQ-R C Controller Module User's Manual

When using MELSEC iQ-R series modules

The following describes the precautions when using MELSEC iQ-R series modules.

■CC-Link IE Controller Network module

- The module cannot be used as a relay station for the interlink transmission function or the routing functions. To use either of those functions, use a CC-Link IE Controller Network module controlled by a programmable controller CPU as a relay station.
- An interrupt sequence program cannot be started.
- The dynamic routing function cannot be used.
- The IP packet transfer function using the Ethernet port of C Controller module is not available.
- For a C Controller module with firmware version "15" or earlier, the number of send points extension by using link points extended setting cannot be used.

■CC-Link IE Field Network master/local module

- The module cannot be used as a relay station for the interlink transmission function or the routing functions. To use either of those functions, use a CC-Link IE Field Network master/local module controlled by a programmable controller CPU as a relay station.
- An interrupt sequence program cannot be started.
- It cannot be used as a submaster station.
- The dynamic routing function cannot be used.
- The IP packet transfer function using the Ethernet port of C Controller module is not available.
- The high-speed remote net of communication mode cannot be used.

■CC-Link system master/local module

- An interrupt sequence program cannot be started.
- The automatic CC-Link start function cannot be used.
- The standby master function cannot be used.
- The remote I/O net mode cannot be used.
- The master station duplex function cannot be used.
- The station-based block data assurance cannot be used.

■Serial communication module

- Only the nonprocedural protocol can be used.

■Ethernet interface module with built-in CC-Link IE

- The Ethernet function cannot be used.

■CC-Link IE TSN master/local module

- The module cannot be used as a relay station for the interlink transmission function or the routing functions. To use either of those functions, use a CC-Link IE TSN master/local module controlled by a programmable controller CPU as a relay station.
- An interrupt sequence program cannot be started.
- The dynamic routing function cannot be used.
- The IP packet transfer function using the Ethernet port of C Controller module is not available.
- The co-recording function cannot be used.
- The TSN HUB setting cannot be used.

■CC-Link IE TSN master/local module (RJ71GN11-T2)

- The setting for low-speed of the multiple period setting cannot be changed. (Fixed to "×16")
- The number of send points extension by using the link points extended setting cannot be used.
- The master station shift function cannot be used.

■Motion module

- The module cannot be used as a relay station for the interlink transmission function or the routing functions. To use either of those functions, use a CC-Link IE TSN master/local module controlled by a programmable controller CPU as a relay station.
- An interrupt sequence program cannot be started.
- The dynamic routing function cannot be disabled.
- The IP packet transfer function using the Ethernet port of C Controller module is not available.
- The inter-module synchronization function cannot be used.
- The simple motion mode cannot be used.
- The co-recording function cannot be used.
- The TSN HUB setting cannot be used.
- The communication mode setting cannot be used. The module communicates in unicast mode.
- The setting for low-speed of the multiple period setting cannot be changed. (Fixed to "×16")

When using MELSEC-Q series modules

The following describes the precautions when using MELSEC-Q series modules.

■FL-net (OPCN-2) interface module

- The word block read/write request messages using the message transmission function cannot be received.
- The auto refresh function cannot be used.

■MELSECNET/H network module

- Remote I/O net cannot be used.
- The module cannot be used as a relay station for the interlink data transmission function or the routing functions. To use either of those functions, use a MELSECNET/H network module controlled by a programmable controller CPU as a relay station.
- An interrupt sequence program cannot be started.
- The network diagnostic function cannot be used.
- The module cannot be used in the simple dual-structured system.
- The debug mode cannot be set.

Precautions for MELSECWinCPU module system configuration

Pay attention to the following when configuring a MELSECWinCPU module system by using a MELSECWinCPU module.

Internal current consumption of MELSECWinCPU modules

The internal current consumption of MELSECWinCPU modules is 4.4A. MELSECWinCPU modules use a larger current compared to other modules.

When configuring a MELSECWinCPU module system, ensure that the total internal current consumption of modules in the system does not exceed the rated output current of the power supply module. Configure a system so that the internal current consumption of the entire system is less than the rated output current of the power supply module.

For the method for configuring a system appropriately, refer to the following.

☞ Page 98 Consideration for internal current consumption

Module control

MELSECWinCPU modules do not support controlling modules using the following:

- Inter-module synchronization function
- Function block (FB)
- Multiple CPU dedicated instruction
- Module dedicated instruction (excluding JP.SEND and JP.RECV)

When using MELSEC iQ-R series modules

The following describes the precautions when using MELSEC iQ-R series modules.

■CC-Link IE Controller Network module

- The module cannot be used as a relay station for the interlink transmission function or the routing functions. To use either of those functions, use a CC-Link IE Controller Network module controlled by a programmable controller CPU as a relay station.
- An interrupt sequence program cannot be started.
- The dynamic routing function cannot be used.
- The IP packet transfer function using the Ethernet port of MELSECWinCPU module is not available.
- The number of send points extension by using the link points extended setting cannot be used.
- The module cannot be used in a redundant system.

■CC-Link IE TSN master/local module

- The module cannot be used as a relay station for the interlink transmission function or the routing functions. To use either of those functions, use a CC-Link IE TSN master/local module controlled by a programmable controller CPU as a relay station.
- An interrupt sequence program cannot be started.
- The dynamic routing function cannot be used.
- The IP packet transfer function using the Ethernet port of MELSECWinCPU module is not available.
- The time synchronization function cannot be used.

■CC-Link system master/local module

- An interrupt sequence program cannot be started.
- The automatic CC-Link start function cannot be used.
- The standby master function cannot be used.
- The remote I/O net mode cannot be used.
- The master station duplex function cannot be used.
- The station-based block data assurance cannot be used.
- The remote device station initial setting procedure registration function cannot be used.
- The scan mode setting cannot be used.

■Serial communication module

- Only the nonprocedural protocol can be used.

Precautions when using a recorder module or camera recorder module

Pay attention to the following when configuring a system by using a recorder module/camera recorder module.

Combinations of modules

When configuring a system by using the recorder module/camera recorder module and any of the modules in the table below, select "Online" for the following item in "Module Parameter" of each module: "Basic Settings" ⇨ "Various Operations Settings" ⇨ "Mode Settings".

Module	Model
MES interface module	RD81MES96, RD81MES96N (firmware version "04" or earlier)
High speed data logger module	RD81DL96 (firmware version "08" or earlier)
OPC UA server module	RD81OPC96 (firmware version "04" or earlier)

Precautions when using a C intelligent function module

Pay attention to the following when configuring a system by using a C intelligent function module.

Combinations of modules

When configuring a system by using a C intelligent function module (RD55UP12-V) and any of the modules in the table below, select "Online" for the following item in "Module Parameter" of each module: "Basic Settings" ⇨ "Various Operations Settings" ⇨ "Mode Settings".

Module	Model
MES interface module	RD81MES96, RD81MES96N (firmware version "04" or earlier)
High speed data logger module	RD81DL96 (firmware version "08" or earlier)
OPC UA server module	RD81OPC96 (firmware version "04" or earlier)

Startup time of a C intelligent function module

The startup time of a C intelligent function module may vary depending on the firmware version.

To make a system program run on the startup of a C intelligent function module, configure an interlock using input/output signals.

Running a system program without an interlock may damage machines or cause accidents due to changes in module behavior caused by the difference in firmware versions resulting from a newly purchased or replaced module, or by the changes in the firmware version after a firmware update.

For details on the input/output signals, refer to the following.

 MELSEC iQ-R C Intelligent Function Module User's Manual (Application)

Precautions when using an MES interface module (RD81MES96N)

Pay attention to the following when configuring a system by using an MES interface module (RD81MES96N).

Combinations of modules

When configuring a system by using an MES interface module (RD81MES96N) and any of the modules in the table below, select "Online" for the following item in "Module Parameter" of each module: "Basic Settings" ⇨ "Various Operations Settings" ⇨ "Mode Settings".

Module	Model
MES interface module	RD81MES96, RD81MES96N (firmware version "04" or earlier)
High speed data logger module	RD81DL96 (firmware version "08" or earlier)
OPC UA server module	RD81OPC96 (firmware version "04" or earlier)

Startup time of an MES interface module (RD81MES96N)

The startup time of an MES interface module (RD81MES96N) may vary depending on the firmware version.

To make a system program run on the startup of an MES interface module (RD81MES96N), configure an interlock using input/output signals.

Running a system program without an interlock may damage machines or cause accidents due to changes in module behavior caused by the difference in firmware versions resulting from a newly purchased or replaced module, or by the changes in the firmware version after a firmware update.

For details on the input/output signals, refer to the following.

 MELSEC iQ-R MES Interface Module User's Manual (Application)

Precautions when using an OPC UA server module

Pay attention to the following when configuring a system by using an OPC UA server module.

Startup time of an OPC UA server module

The startup time of an OPC UA server module may vary depending on the firmware version.

To make a system program run on the startup of an OPC UA server module, configure an interlock using input/output signals.

Running a system program without an interlock may damage machines or cause accidents due to changes in module behavior caused by the difference in firmware versions resulting from a newly purchased or replaced module, or by the changes in the firmware version after a firmware update.

For details on the input/output signals, refer to the following.

 MELSEC iQ-R OPC UA Server Module User's Manual (Application)

Precautions when using a high speed data logger module

Pay attention to the following when configuring a system by using a high speed data logger module.

Startup time of a high speed data logger module

The startup time of a high speed data logger module may vary depending on the firmware version.

To make a system program run on the startup of a high speed data logger module, configure an interlock using input/output signals.

Running a system program without an interlock may damage machines or cause accidents due to changes in module behavior caused by the difference in firmware versions resulting from a newly purchased or replaced module, or by the changes in the firmware version after a firmware update.

For details on the input/output signals, refer to the following.

 MELSEC iQ-R High Speed Data Logger Module User's Manual (Application)

Precautions when using a high speed data communication module

Pay attention to the following when configuring a system by using a high speed data communication module.

Startup time of a high speed data communication module

The startup time of a high speed data communication module may vary depending on the firmware version.

To make a system program run on the startup of a high speed data communication module, configure an interlock using input/output signals.

Running a system program without an interlock may damage machines or cause accidents due to changes in module behavior caused by the difference in firmware versions resulting from a newly purchased or replaced module, or by the changes in the firmware version after a firmware update.

For details on the input/output signals, refer to the following.

 MELSEC iQ-R High Speed Data Communication Module User's Manual (Application)





2 ASSIGNMENT FOR MODULES

This chapter describes how to assign slot numbers, I/O numbers, CPU numbers, and control CPUs to modules.

These assignments can be set by placing the same modules in the actual system on the "Module Configuration" window using the engineering tool.

These assignments can also be set by reading system parameters or actual system configuration. ( GX Works3 Operating Manual)

The following table lists the setting availability on the module configuration window or system parameters for each item.

Item	Module configuration window	System parameter
Base unit model	<input type="radio"/>	<input type="radio"/>
Power supply module model	<input type="radio"/>	<input type="radio"/>
Extension cable model	<input type="radio"/>	<input type="radio"/>
Module model	<input type="radio"/>	<input type="radio"/>
Module order	<input type="radio"/>	<input type="radio"/>
Module I/O number ( Page 117 I/O Numbers of Modules)	<input type="radio"/>	<input type="radio"/>
Module status setting ( Page 123 Module status setting)	<input type="radio"/>	<input type="radio"/>
Number of points of an empty slot ( Page 122 I/O numbers of an empty slot)	<input type="radio"/>	<input type="radio"/>
Control CPU ( Page 128 Control CPU)	<input type="radio"/>	<input type="radio"/>
Number of slots on a base unit ( Page 114 Setting the number of slots)	<input type="checkbox"/>	<input type="radio"/>
Number of points of a module	<input type="checkbox"/>	<input type="radio"/>

Point

Set assignments either on the module configuration window or in the system parameters depending on the application.

- Module configuration window: To use information unique to each module, such as the number of occupied points, as it is
- System parameter: To change the number of slots on a base unit or the number of occupied points of a module

2.1 Slot Numbers on a Base Unit

Slot numbers are sequentially assigned starting from the slot on the right side of the CPU slot.

When extension base units are connected, slot numbers are assigned to the main base unit first, and successively to the extension base units (1st level to 7th level).

An extension level needs to be set to the MELSEC-Q series extension base unit with the extension level setting connector pin.

([Page 172](#) Setting method with connector pin for extension level setting)

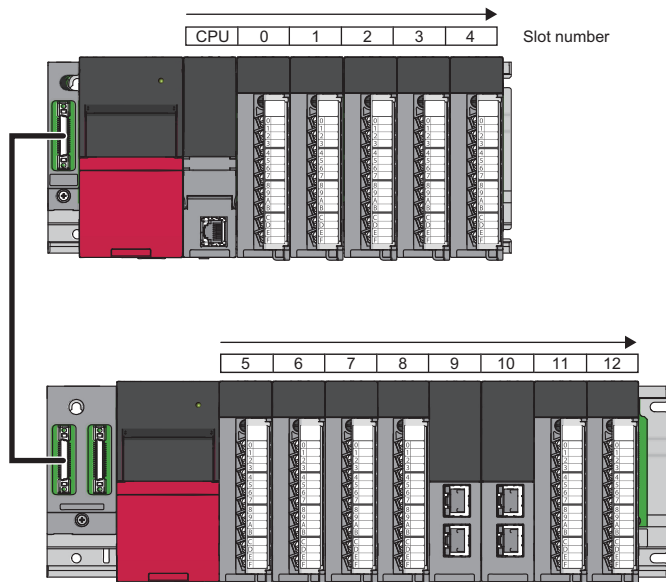

If a module which occupies two slots is mounted, slot numbers for two modules are assigned.

Setting the number of slots

The number of slots for each base unit can be set within the range of 1 to 12. Set the number of slots for the following purposes.

- To secure slots so that the base unit can be changed to the one having the different number of slots in the future
- To keep the same number of slots even after the base unit used in the existing system is changed

 [Navigation window] ⇒ [System Parameter] ⇒ [I/O Assignment] ⇒ [Base/Power/Extension Cable Setting]

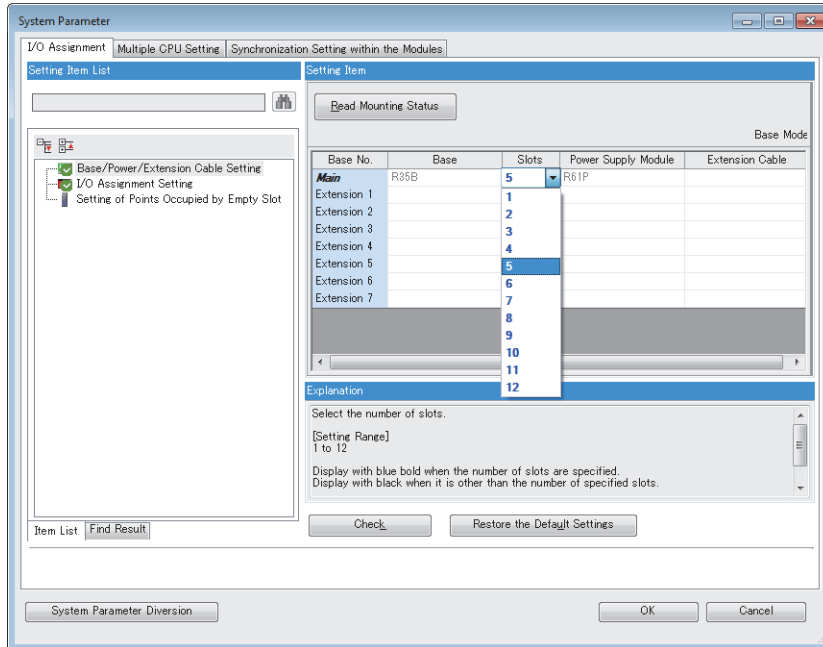

■When the number of set slots is more than the number of actual slots

Slots corresponding to the set number are occupied, where the slots exceeding the actual number are regarded as empty slots.

Ex.

When the number of slots is set to eight for the base unit with five slots, three slots are regarded as empty slots.

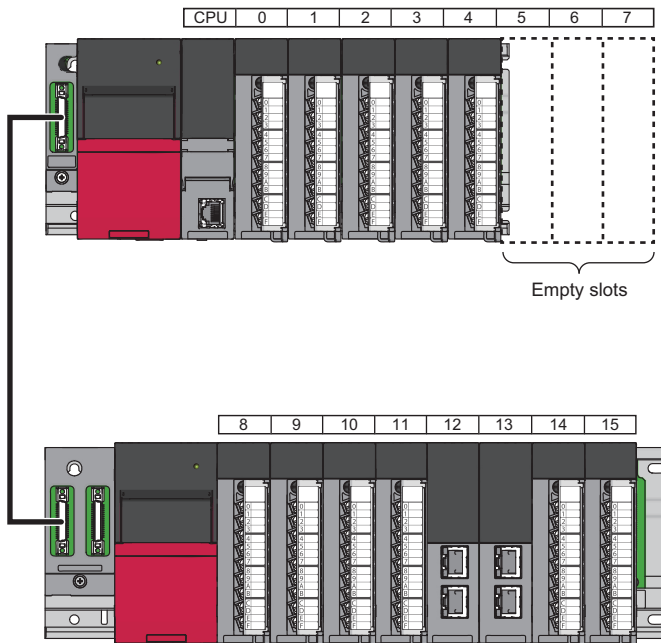

Point

The number of points for empty slots can be changed on the "Module Configuration" window, or in "Setting of Points Occupied by Empty Slot" of the [I/O Assignment] tab on the "System Parameter" window. (→ Page 122 I/O numbers of an empty slot)

■When the number of set slots is less than the number of actual slots

Slots corresponding to the set number are occupied, where slots that are out of the set range are prohibited from mounting a module, and the slot number is not assigned.

Ex.

When the number of slots is set to five for the base unit with eight slots, three slots will be use-prohibited.

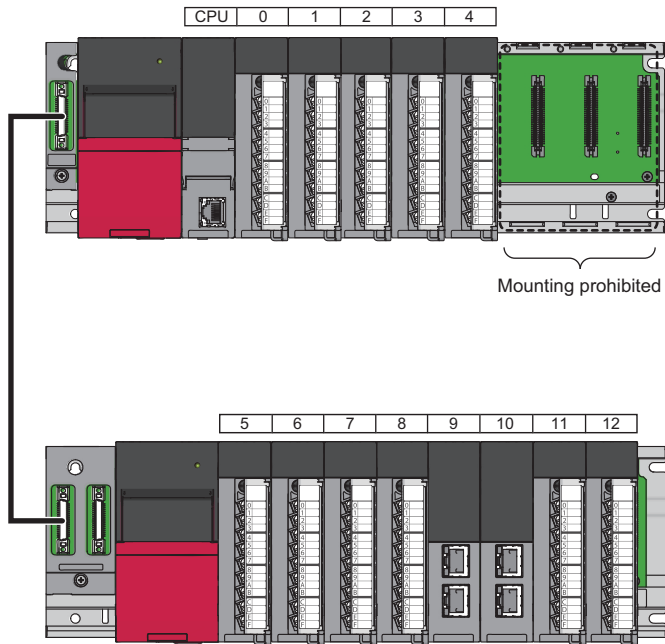

2.2 I/O Numbers of Modules

An I/O number is a number (hexadecimal) assigned to I/O modules and intelligent function modules to communicate data with the CPU module or remote head module. On/off data are classified into two types: input and output, and the symbol, "X" for input, and "Y" for output, is added in front of the I/O number.

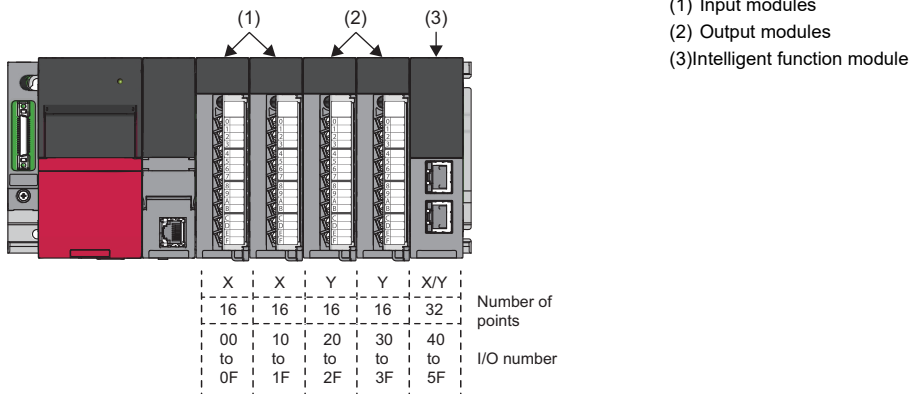

Automatic setting of I/O numbers

I/O numbers are automatically assigned in sequential order. On the main base unit, the I/O number starts from 00H, which is given to the module on the right side of the CPU module or remote head module.

On the extension base unit (1st level), the I/O number starts from the next number of the last I/O number on the main base unit.

Each slot on the base unit occupies I/O numbers corresponding to the number of points of the module mounted.

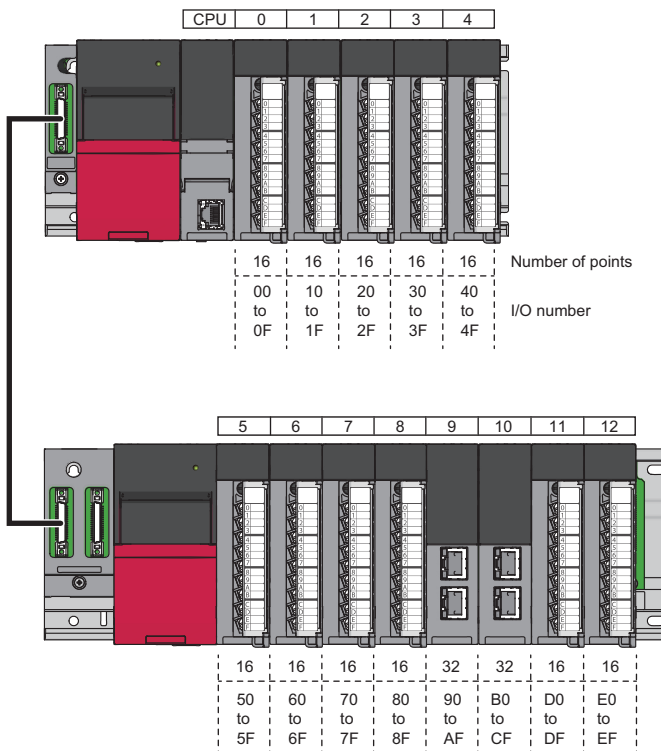

Upon placing a module on the "Module Configuration" window, the I/O numbers are automatically assigned according to the number of occupied points of the module.

Even though the mounting position of the module is changed, the I/O numbers once assigned remain unchanged.

When the CPU module is the RnENCPU, the I/O numbers of the RnENCPU (network part) are automatically assigned as shown below. *1*2

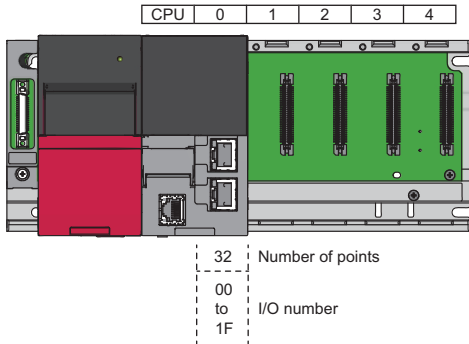

*1 The RnENCPU (network part) occupies I/O numbers of 32 points.

*2 When modules are already placed on the engineering tool, the I/O numbers of empty slots are assigned.



The mounted modules and their I/O numbers can be checked on the "System Monitor" window using the engineering tool. (📖 GX Works3 Operating Manual)

System Monitor Main Base(R38B)

Module Find Target Find

Operation Status: No. 1 No. 2 No. 3 No. 4
RUN

Display Setting... Monitoring Stop Monitoring

	Power Supply	CPU	I/O0	I/O1	I/O2	I/O3	I/O4	I/O5	I/O6	I/O7
Start I/O No.	-	3E00	0000	0010	0020	0030	0040	0050	0060	0070
Points	-	-	16 Point	16 Point	16 Point	16 Point	16 Point	16 Point	16 Point	16 Point
Module Name	R61P	R32CPU	R60AD4	R60DA4	-	-	-	-	-	-
Error Status	-	-	-	-	-	-	-	-	-	-
Module Configuration										
Control CPU	-	-	-	-	-	-	-	-	-	-
Network Information (Port 1)	-	-	-	-	-	-	-	-	-	-
IP Address (Port1 IPv4)	-	192.168.3.39	-	-	-	-	-	-	-	-
Module Synchronous Status	-	-	-	-	-	-	-	-	-	-

Product Information List... Event History... Create File... Error Status Legend: Major, Moderate, Minor, Unit/Base Access Error. Close

Changing I/O numbers

Upon placing a module on the "Module Configuration" window, the I/O numbers are automatically assigned according to the number of occupied points of the module. The assigned I/O numbers, however, can be changed for each module.

- To eliminate the need of modification due to an overlap of I/O numbers after the module is changed to a module having a different number of occupied points
- To reduce the program modifications when using an existing program by assigning modules according to the I/O numbers that have already been used in the program

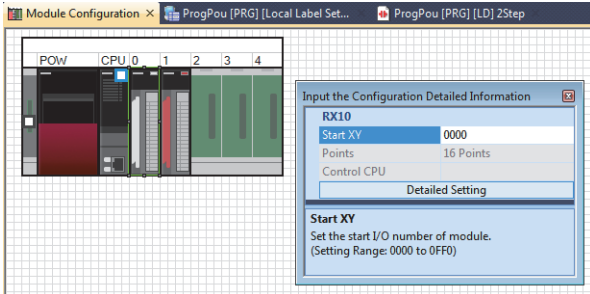

Point

I/O numbers can be freely assigned beyond a boundary between the MELSEC iQ-R series and the MELSEC-Q series, being free from the restriction of assignment orders.

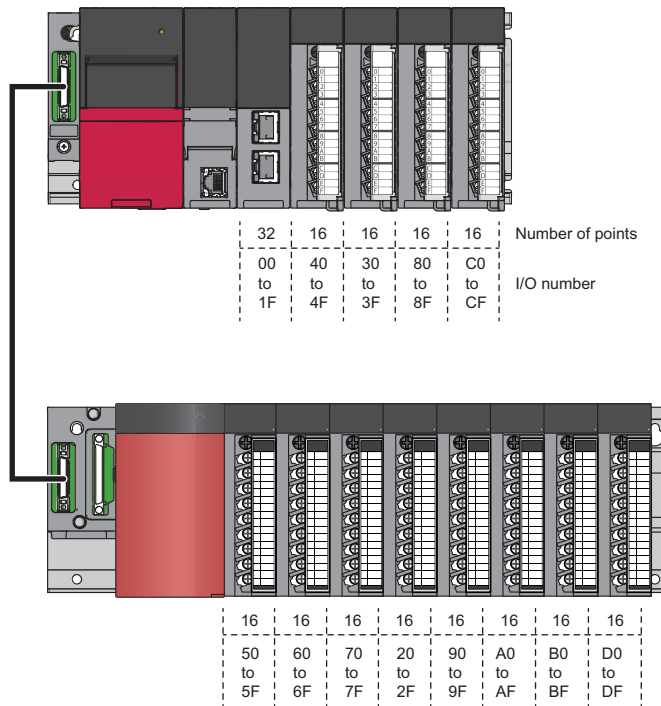

■Precautions

- Set the same model as the one actually mounted.
- The CPU module or remote head module that is not set as actually mounted denies access.
- The number of I/O points of a module can be changed in "I/O Assignment Setting" of the [I/O Assignment] tab on the "System Parameter" window.
- If the number of I/O points set in the parameters differs from that of the module actually mounted, the number of I/O points will be as follows:

Setting	Operation	Remarks
The number of I/O points set in the parameters is less than that of the module actually mounted.	The available number of points for the mounted I/O modules is reduced to the set number of points.	Intelligent function modules do not permit the setting of a fewer number of I/O points.
The number of I/O points set in the parameters is more than that of the module actually mounted.	The number of I/O points exceeding the actual number of I/O points is not used in the mounted I/O modules and intelligent function modules.	—

- Set same modules as in the actual system on the "Module Configuration" window. Because the settings of the engineering tool control the module operation, a setting that is different from the actual configuration may result in unintended operation.
- When changing the default I/O numbers, setting the I/O numbers to all the modules is recommended. I/O numbers of a module that is not set in the engineering tool are assigned following the I/O numbers of the module already set, which may cause an overlap of I/O numbers.

Ex.

I/O numbers overlap as a result of setting the I/O numbers up to the module on slot No.4.

- I/O numbers set by using the engineering tool

Set the start I/O number 40 to the module on slot No.3, and 30 to the module on slot No.4.

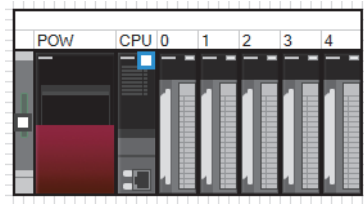

Slot	Module Name	Module Status Setting	Points	Start XY
Main				
CPU	R04CPU(Host Station)			3E00
0(0-0)	RX10	No Setting	16 Points	0000
1(0-1)	RX10	No Setting	16 Points	0010
2(0-2)	RX10	No Setting	16 Points	0020
3(0-3)	RX10	No Setting	16 Points	0040
4(0-4)	RX10	No Setting	16 Points	0030

- I/O numbers in the actual system

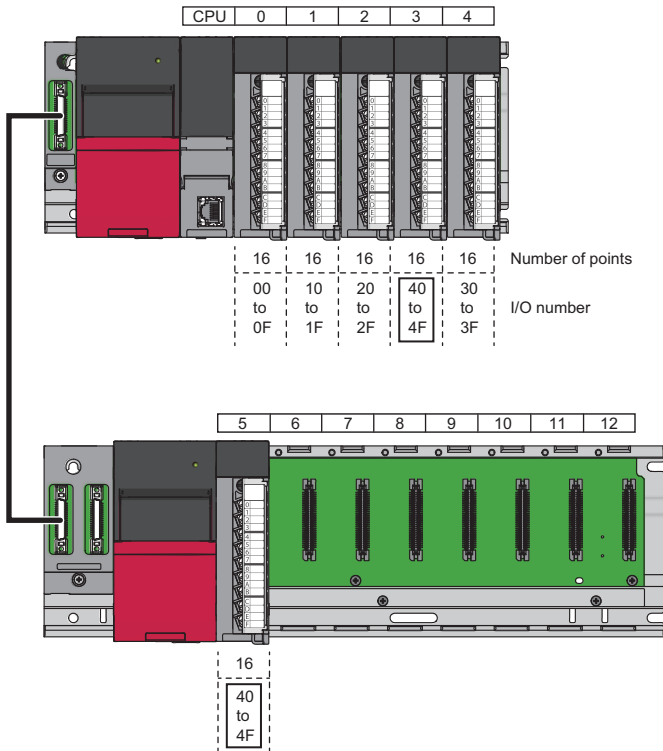

I/O numbers of the module on slot No.5, which is not set in the engineering tool, are assigned following the I/O numbers of the module on slot No.4. This results in an overlap of I/O numbers.

Set the I/O numbers of the module on slot No.5 in the parameter so that they do not overlap.

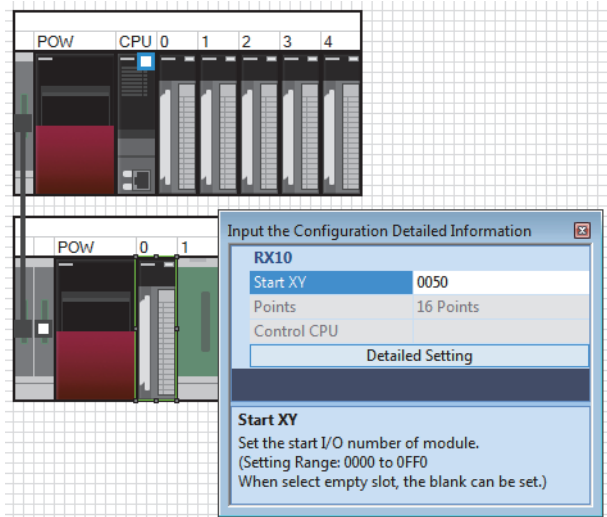

- To set the module reserved for future use, or when an already set module is not to be mounted, perform the module status setting. (Page 123 Module status setting)

I/O numbers of an empty slot

An empty slot is a slot where a module is not mounted, and occupies 16 points by default.

I/O numbers and the number of points can be set to empty slots for future use.

The number of I/O points can be changed for all empty slots at once by selecting the CPU module or remote head module on the "Module Configuration" window as shown below.

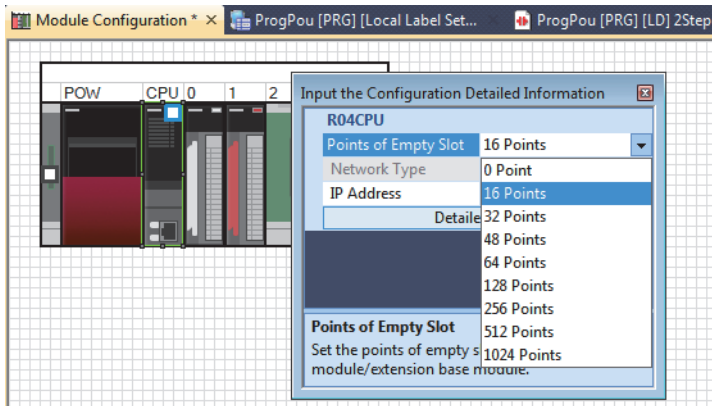

Module status setting

The module status setting makes it possible to set the module status such as reserved status and disabled status, interpreting a configured module in the engineering tool as an empty slot.

The following table summarizes the application of the module status setting.

Status	Application
Reserved status	<ul style="list-style-type: none"> To operate the system allocating a module on the "Module Configuration" window on the engineering tool, but actually not mounting the module To reserve the I/O numbers of a module for future use
Disabled status	<ul style="list-style-type: none"> To disable operation of an actually mounted module

The change of the parameter settings is not reflected in the module where the module status setting has been performed. In addition, the following operations have no effect on the module where the module status setting has been performed:

- Setting a remote password
- Executing a program that accesses the set target module

Set the module status as shown below. (GX Works3 Operating Manual)

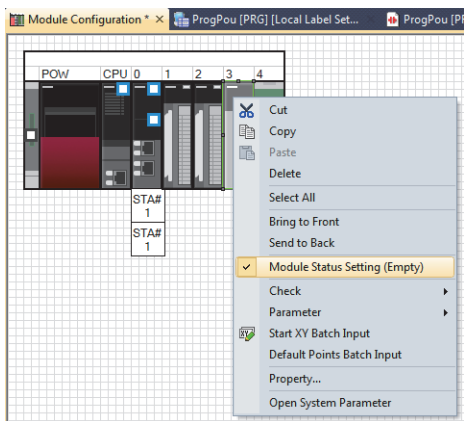

Ex.

To operate the system allocating a module on the "Module Configuration" window on the engineering tool, but actually not mounting the module

- Module configuration window

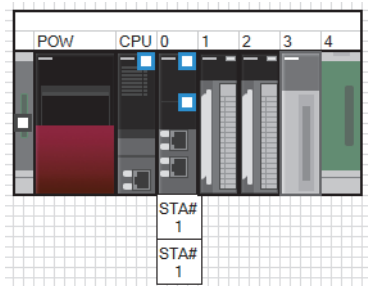

- Actual system

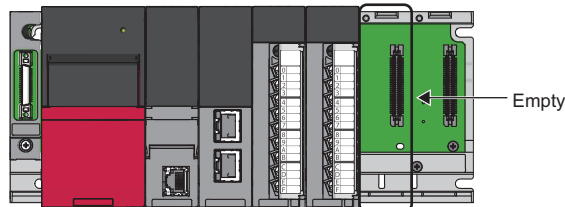

When the module status is set, the set target module is high-lighted, and regarded as an empty slot.

Writing the module configuration to the programmable controllers allows operation even without mounting modules actually.

Assigning I/O numbers in the device station

Network systems such as CC-Link IE Field Network can be controlled by assigning input "X" and output "Y", which are in the device of the CPU module, to the I/O modules and intelligent function modules in the device station.

Ex.

Controlling a module connected to the head module on CC-Link IE Field Network

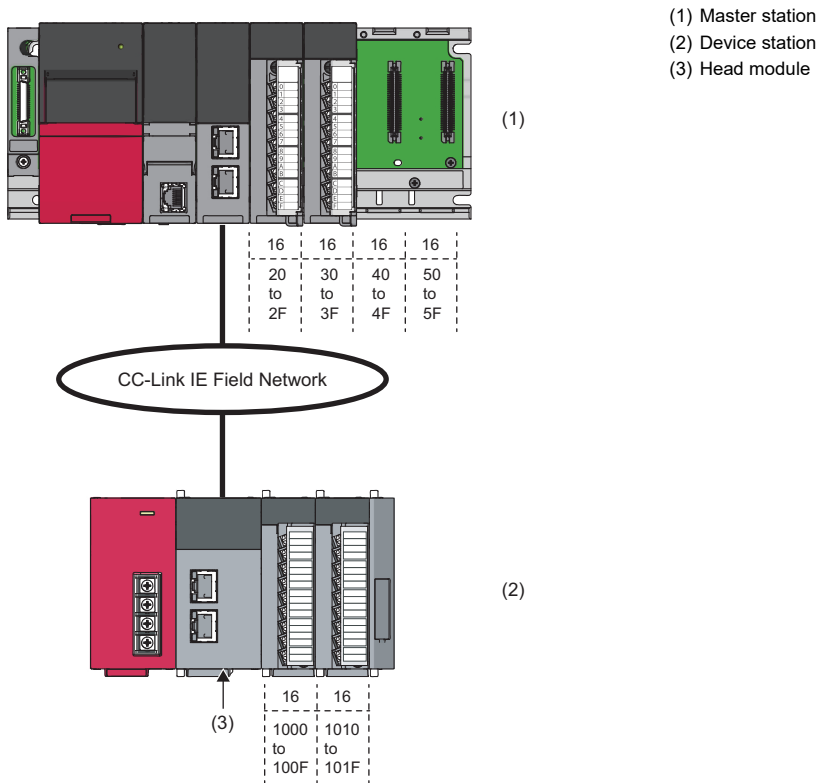

Available I/O numbers

Assign the I/O numbers (including those for future expansion) or later that will be used by the CPU module to which the master station is mounted.

■Precautions

- The I/O numbers used by the CPU module and the I/O numbers for the network refresh destination (devices on the CPU module side) used by the device station on a network such as CC-Link IE Field Network cannot overlap.
- The I/O numbers of the CPU module are used from the start of the input/output (X/Y). If there is a possibility of connecting more I/O modules and intelligent function modules to the CPU module, reserve I/O numbers for modules to be added for future expansion.
- I/O numbers within the range of X/YFFF that are not used by the CPU module can also be used as I/O numbers for the network refresh destination.

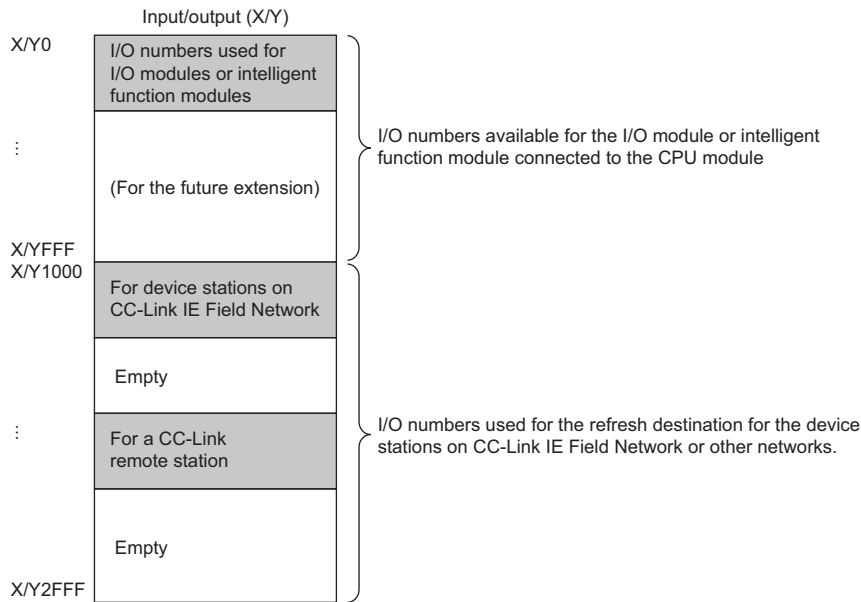

2.3 CPU Numbers

CPU numbers refer to the numbers for identifying the CPU modules on the multiple CPU system or the remote head modules on the redundant system.*1

*1 For details on the redundant system configuration of remote head modules, refer to the following.

📖 MELSEC iQ-R CC-Link IE Field Network Remote Head Module User's Manual (Application)

The CPU module mounted on the CPU slot in the base unit is CPU No.1. CPU No.2, CPU No.3, and CPU No.4 are sequentially assigned starting from the module on the right side of CPU No.1.

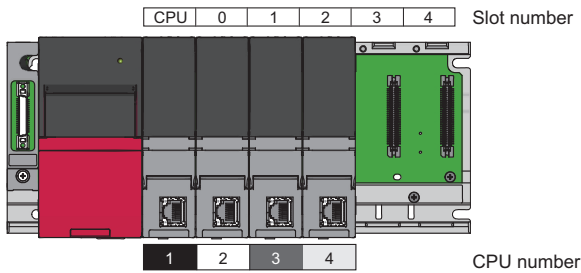

The multiple CPU system configuration requires the specification of mounted CPU modules, so that the I/O numbers are assigned to the CPU modules as well. The following table lists the start I/O numbers assigned to each CPU module.

CPU number	Start I/O number of CPU module
CPU No.1	3E00H
CPU No.2	3E10H
CPU No.3	3E20H
CPU No.4	3E30H

Reservation setting of the CPU module

The reservation setting of the CPU modules excluding CPU No.1 is possible to reserve CPU numbers for the CPU modules to be mounted in the future. (Page 123 Module status setting)

However, if an actually mounted CPU module is set to the disabled status, the module is not to be regarded as an empty slot.

- Module configuration window

Perform the module reservation setting on the CPU module at slot number 1.

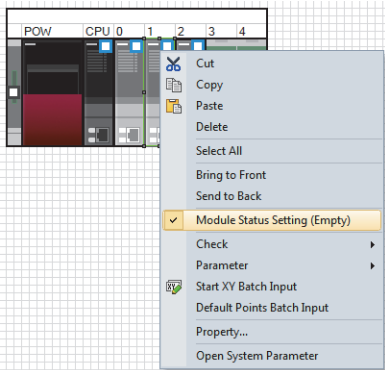

- Actual system

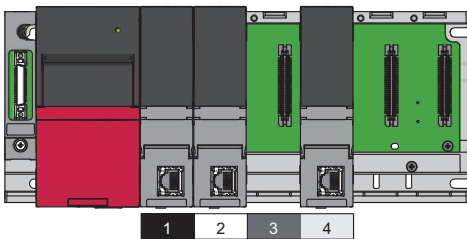

A reserved CPU number of the CPU module is assigned even though the CPU module is not mounted actually.

The CPU module can be mounted on the CPU slot and the slot number 0 to 6, where the opening slot between CPU modules can be reserved as an empty slot. I/O modules and intelligent function modules, however, cannot be mounted on the opening slot between CPU modules.

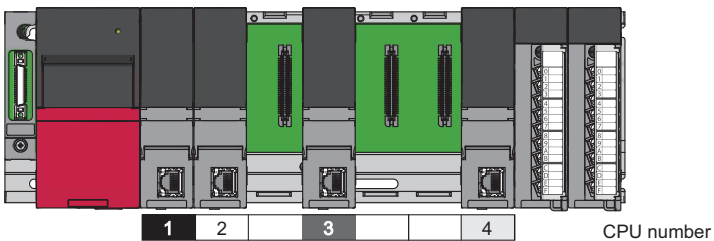

2.4 Control CPU

The control CPU refers to the CPU module that controls I/O modules and intelligent function modules.

In a multiple CPU system, a control CPU must be set for each module. If the control CPU is not set, CPU No.1 controls all the modules.

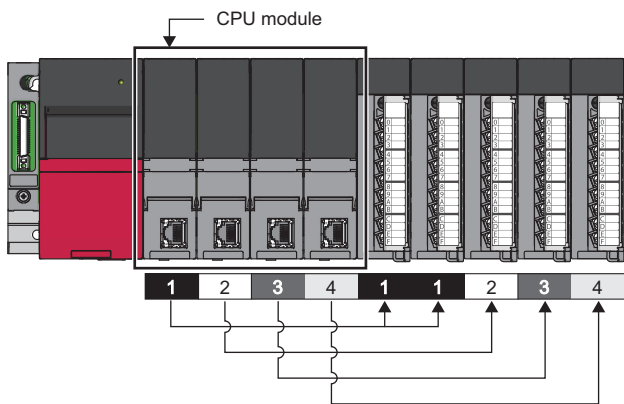

Set the control CPU for each module in the "Module Configuration" window.

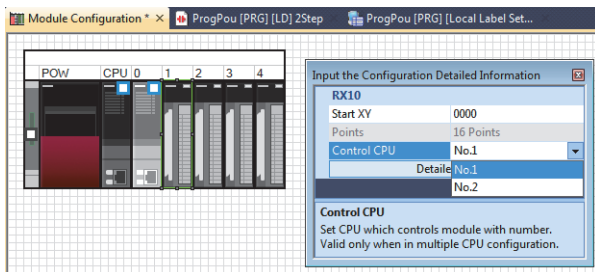

3 PART NAMES

3.1 Power Supply Module

This section describes the part names of the power supply module.

• R62P

• R61SP

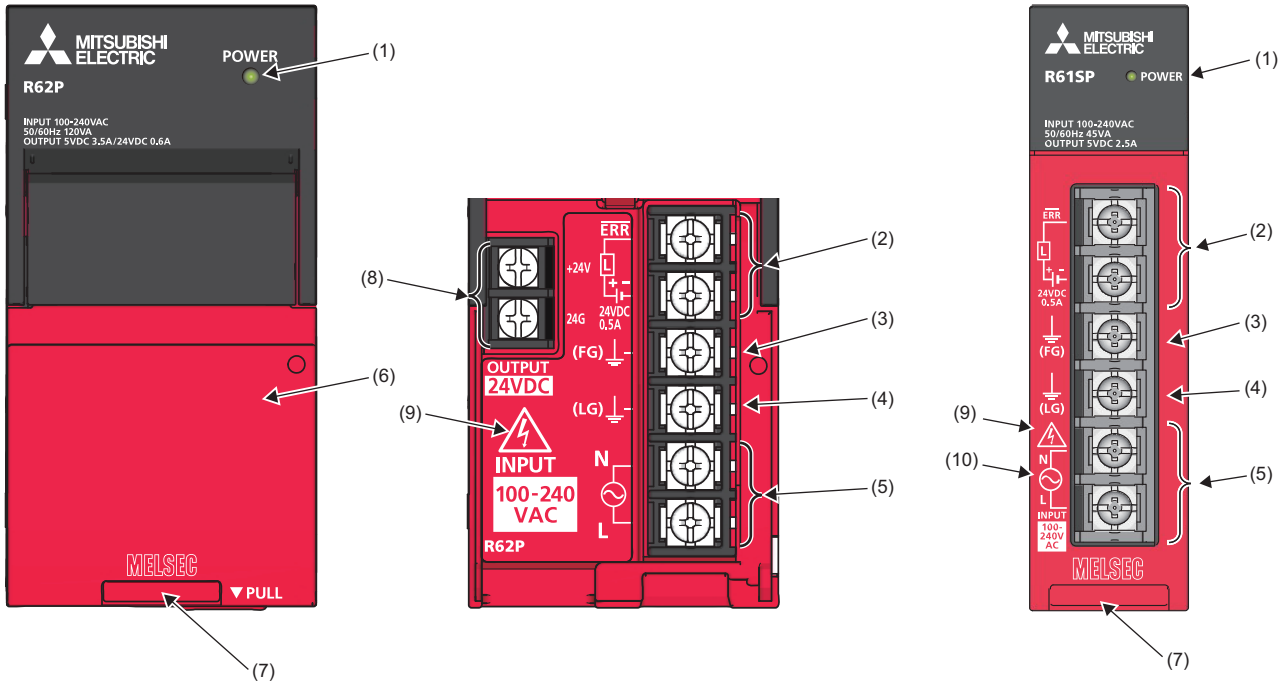

No.	Name	Description
(1)	POWER LED	Indicates the operating status of the power supply module. On: Normal operation Off: Power-off, power failure, or hardware failure (MELSEC iQ-R CPU Module User's Manual (Application))
(2)	ERR contact ^{*3}	<p>■When mounting the module on the main base unit The contact turns on when the entire system operates normally. (M4 screw (M3.5 screw for the R61SP)) This contact turns off (opens) in the following cases:</p> <ul style="list-style-type: none"> • When the power supply module fails • When the power is not supplied • When a stop error (including reset) occurs in the CPU module • When the fuse is blown <p>In a multiple CPU system, the contact turns off when a stop error occurs in any of the CPU modules. When the remote head module is mounted, this contact turns off when moderate or major error (including reset) occurs.</p> <p>■When mounting the module on the extension base unit The contact is off at all times. When the module is mounted on a redundant power supply extension base unit, the following operation is performed:</p> <ul style="list-style-type: none"> • The contact turns on when the power supply module operates normally. (M4 screw) • This contact turns off (opens) when the power supply module fails, the power is not supplied, or the fuse is blown.
(3)	FG terminal ^{*1}	A functional ground terminal connected to the shield pattern of the printed circuit board (M4 screw (M3.5 screw for the R61SP))
(4)	LG terminal ^{*1}	A functional ground terminal for the power supply input filter. For AC input, the terminal has one-half the potential of the input voltage. (M4 screw (M3.5 screw for the R61SP))
(5)	Power input terminal ^{*4}	A power input terminal for the power supply module. The power supply to be connected differs depending on a power supply module. (M4 screw (M3.5 screw for the R61SP)) (Page 137 Performance Specifications of Power Supply Module)
(6)	Terminal cover	A protective cover for the terminal block
(7)	Production information marking	Shows the production information (16 digits) of the module.
(8) ^{*2}	+24V terminal and 24G terminal ^{*5}	Used for a device that requires a supply of 24VDC. (M3.5 screw) The power is supplied to a device through the external wiring.

No.	Name	Description
(9)	Electric shock warning	A warning symbol to warn of the risk of electric shock when the users touch the exposed current-carrying parts
(10)	Alternating current marking	Indicates alternating current marking. Connect an AC power supply to the terminals where this marking is displayed.

*1 Individually ground the FG and LG terminals with a ground resistance of 100 ohms or less.

*2 Only the R62P has these terminals.

*3 Place the cables for the ERR contact output in the control panel and keep the length to 30m or less.

*4 A fuse is built into the power input terminal of L side. Therefore, when the power supply that supplies the power to the power supply module is grounded, connect the grounded side of the power supply to the N terminal and the ungrounded side to the L terminal.

*5 Place the 24VDC output cables in the control panel. The cable length must be 30m or shorter.

3.2 Base Unit

Main base unit

This section describes the part names of the main base unit. (The R312B is used as an example.)

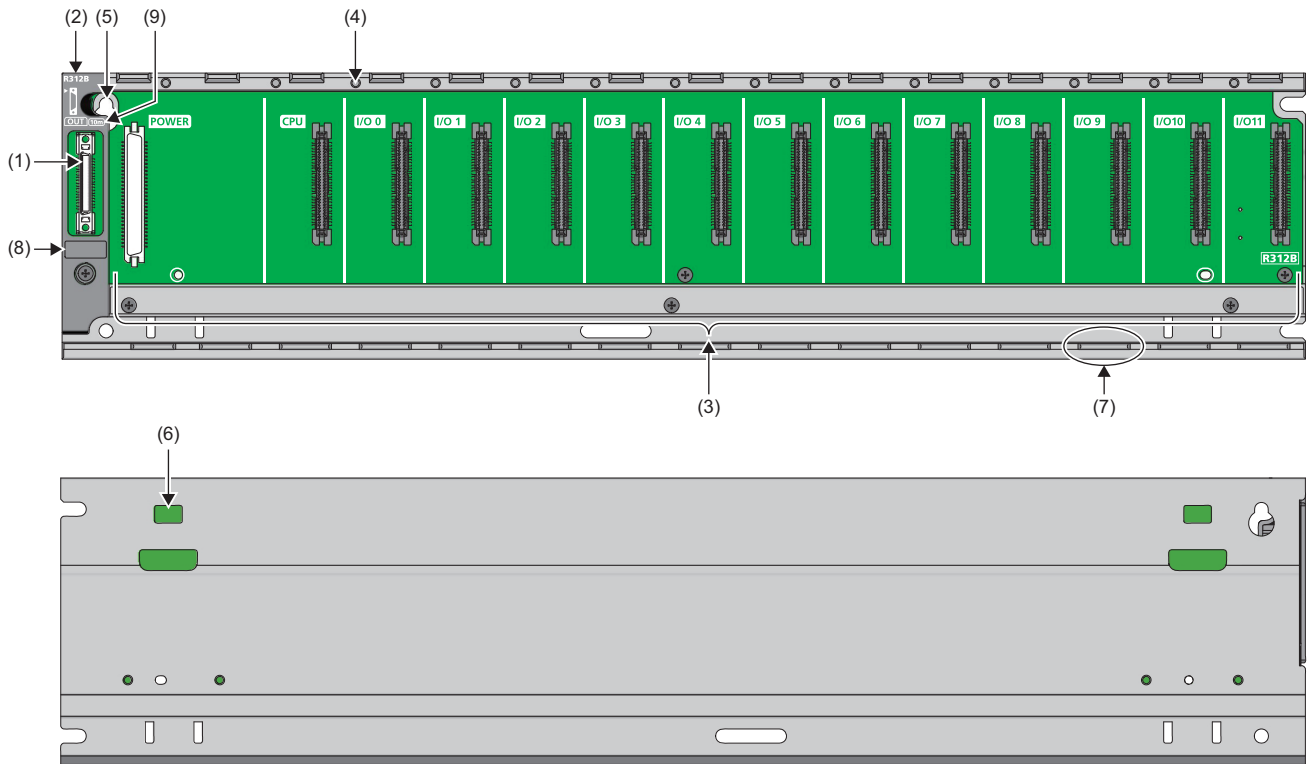

No.	Name	Description
(1)	Extension cable connector (OUT)* ²	A connector for connecting to an extension base unit. A MELSEC iQ-R series extension cable is connected here. To prevent entrance of foreign material, such as dust, into the unused extension cable connector, attach an extension connector protective cover* ¹ .
(2)	Extension connector cover* ²	A protective cover for the extension cable connector
(3)	Module connector	A connector for mounting MELSEC iQ-R series modules. Attach a blank cover module (RG60) to a connector where no module is mounted to prevent entry of foreign matter such as dust.
(4)	Module fixing hole	A screw hole to fix a module to the base unit (M3×12 screw)
(5)	Base unit installation hole	A hole to install a base unit to a control panel (M4 screw)
(6)	DIN rail adapter mounting hole	A hole to mount a DIN rail adapter
(7)	Guide	A guide to mount a module to the base unit
(8)	Production information marking	Shows the production information (16 digits) of the module.
(9)	10m mark* ²	Indicates that the base unit supports the ten-meter extension cable (RC100B).

*1 For details, please consult your local Mitsubishi Electric representative.

*2 Not provided for the slim type main base unit

For the redundant power supply main base unit, the power supply module mounted on the left power supply slot is POWER 1, and the power supply module mounted on the right power supply slot is POWER 2. This number is used to recognize the redundant power supply module when the special relay or special register is used.

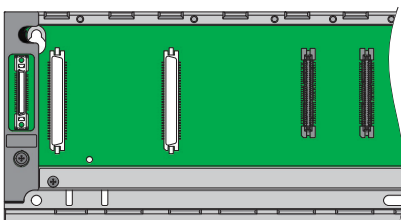

Extension base unit

This section describes the part names of the extension base unit. (The R612B is used as an example.)

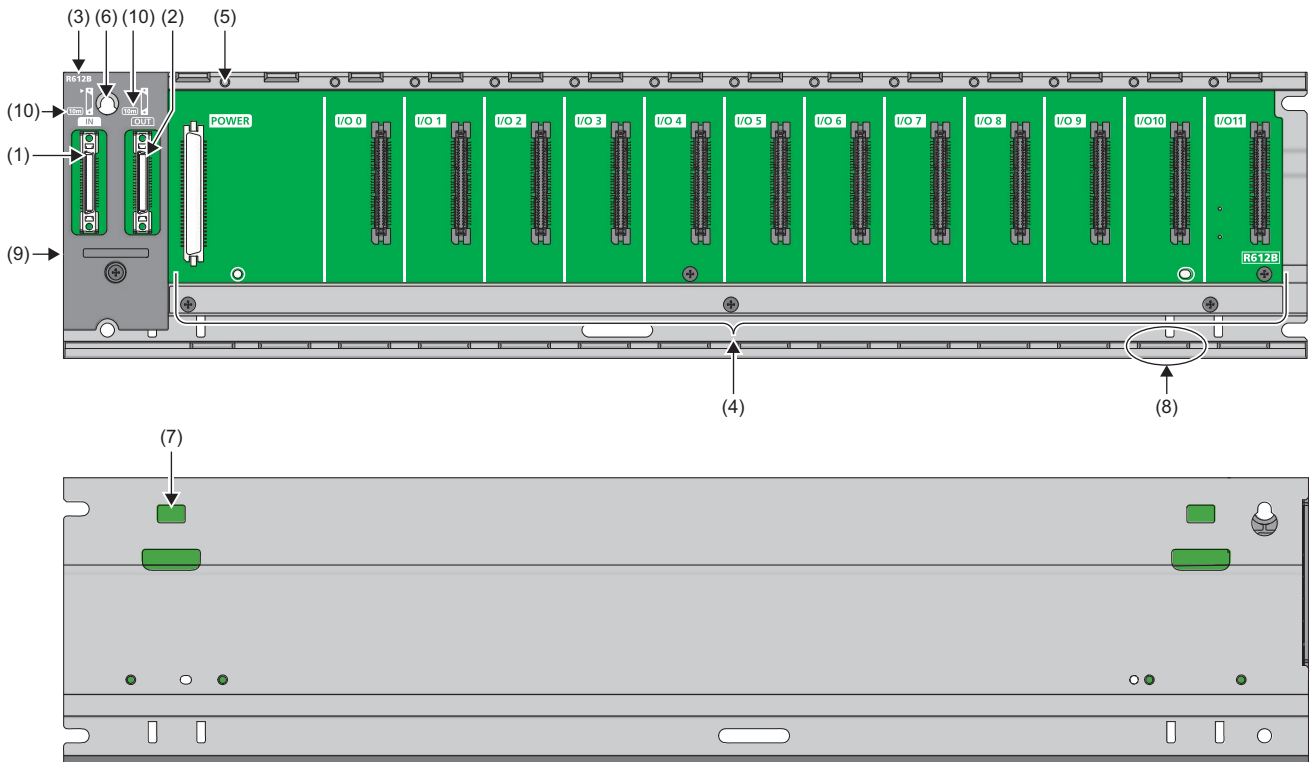

No.	Name	Description
(1)	Extension cable connector (IN)	A connector for connecting to a base unit (upper level). A MELSEC iQ-R series extension cable is connected here.
(2)	Extension cable connector (OUT)	A connector for connecting to a base unit (lower level). A MELSEC iQ-R series extension cable is connected here. To prevent entrance of foreign material, such as dust, into the unused extension cable connector, attach an extension connector protective cover*1.
(3)	Extension connector cover	A protective cover for the extension cable connector
(4)	Module connector	A connector for mounting MELSEC iQ-R series modules. The CPU module and remote head module cannot be mounted on an extension base unit. Attach a blank cover module (RG60) to a connector where no module is mounted to prevent entry of foreign matter such as dust.
(5)	Module fixing hole	A screw hole to fix a module to the base unit (M3×12 screw)
(6)	Base unit installation hole	A hole to install a base unit to a control panel (M4 screw)
(7)	DIN rail adapter mounting hole	A hole to mount a DIN rail adapter
(8)	Guide	A guide to mount a module to the base unit
(9)	Production information marking	Shows the production information (16 digits) of the module.
(10)	10m mark	Indicates that the base unit supports the ten-meter extension cable (RC100B).

*1 For details, please consult your local Mitsubishi Electric representative.

For the redundant power supply extension base unit, the power supply module mounted on the left power supply slot is POWER 1, and the power supply module mounted on the right power supply slot is POWER 2. This number is used to recognize the redundant power supply module when the special relay or special register is used.

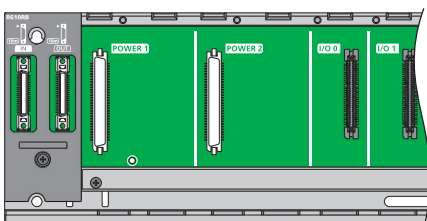

Redundant extension base unit

This section describes the part names of the redundant extension base unit. (The R68WRB is used as an example.)

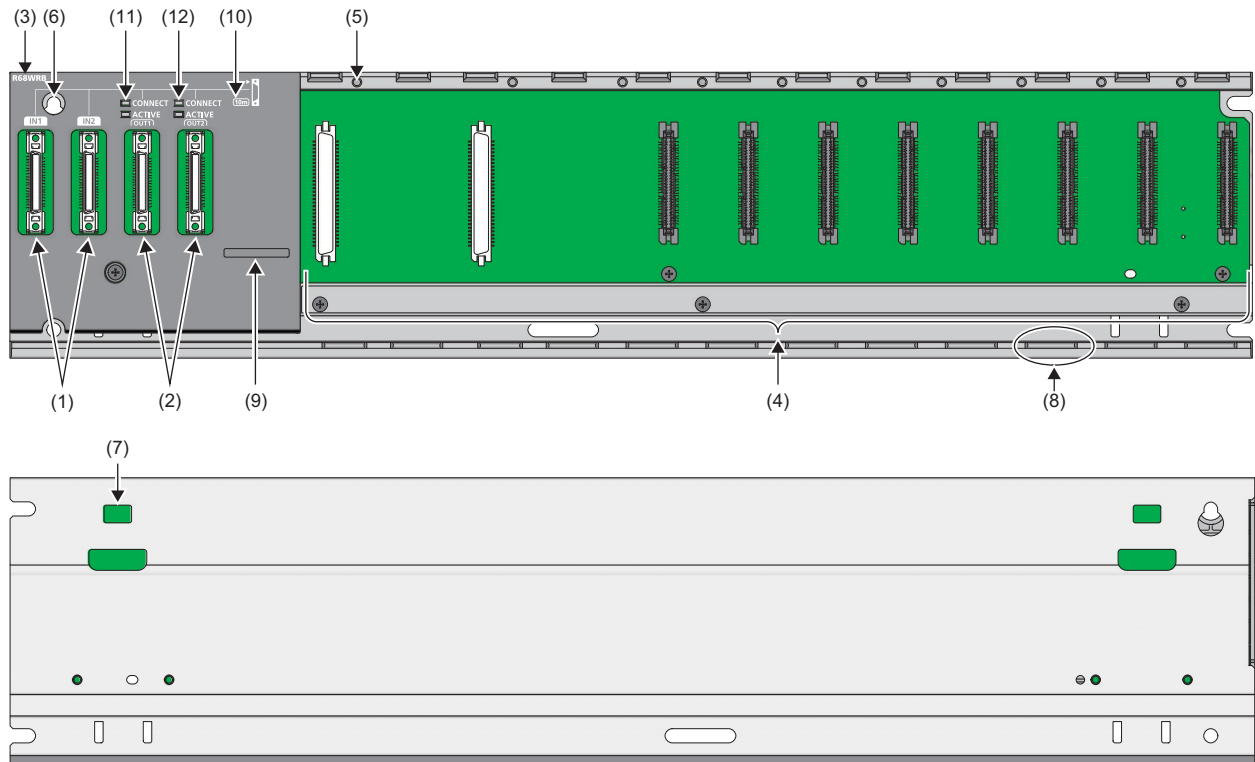

No.	Name	Description
(1)	Extension cable connector (IN1/IN2)	A connector for connecting to a MELSEC iQ-R series base unit (upper level). A MELSEC iQ-R series extension cable is connected here. (Page 170 Connection Method for the Extension Base Unit)
(2)	Extension cable connector (OUT1/OUT2)	A connector for connecting to a MELSEC iQ-R series extension base unit (lower level). A MELSEC iQ-R series extension cable is connected here. (Page 170 Connection Method for the Extension Base Unit) To prevent entrance of foreign material, such as dust, into the unused extension cable connector, attach an extension connector protective cover*1.
(3)	Extension connector cover	A protective cover for the extension cable connector
(4)	Module connector	A connector for mounting a redundant power supply module, an I/O module, and an intelligent function module. The CPU module cannot be mounted on an extension base unit. Attach a blank cover module (RG60) to a connector where no module is mounted to prevent entry of foreign matter such as dust.
(5)	Module fixing hole	A screw hole to fix a module to the base unit (M3×12 screw)
(6)	Base unit installation hole	A hole to install a base unit to a control panel (M4 screw)
(7)	DIN rail adapter mounting hole	A hole to mount a DIN rail adapter
(8)	Guide	A guide to mount a module to the base unit
(9)	Production information marking	Shows the production information (16 digits) of the module.
(10)	10m mark	Indicates that the base unit supports the ten-meter extension cable (RC100B).
(11)	LED	CONNECT Indicates whether the extension cable between the redundant extension base unit (OUT1/OUT2) and the base unit of the next level is connected properly. • On (green): Connected properly • Off: Not connected, extension cable error, or connected improperly
(12)		ACTIVE Indicates whether the extension cable connected to OUT1/OUT2 is active (being used). • On (green): Active • Off: Inactive

*1 For details, please consult your local Mitsubishi Electric representative.

For the redundant extension base unit, the power supply module mounted on the left power supply slot is POWER 1, and the power supply module mounted on the right power supply slot is POWER 2. This number is used to recognize the redundant power supply module when the special relay or special register is used.

RQ extension base unit (for MELSEC-Q series modules)

This section describes the part names of the extension base unit. (The RQ612B is used as an example.)

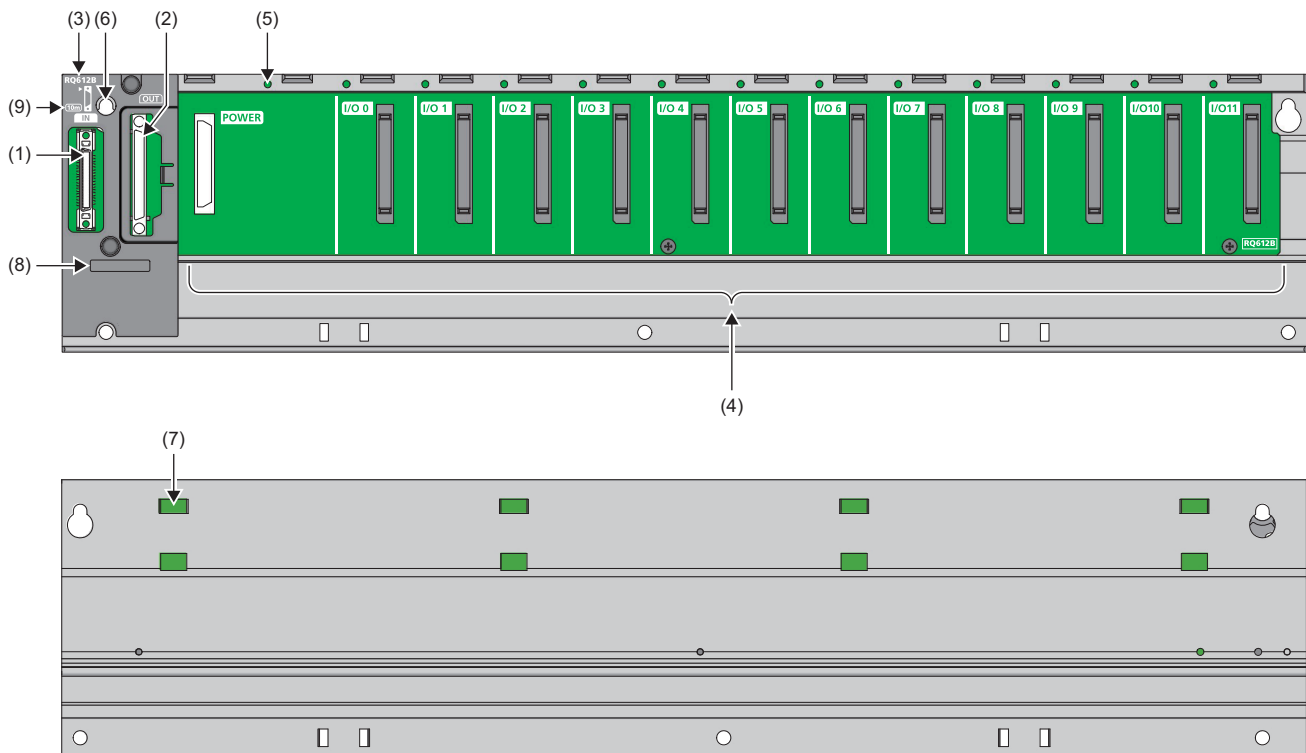

No.	Name	Description
(1)	Extension cable connector (IN)	A connector for connecting to a MELSEC iQ-R series base unit (upper level). A MELSEC iQ-R series extension cable is connected here.
(2)	Extension cable connector (OUT)	A connector for connecting to a MELSEC-Q series base unit (lower level). A MELSEC-Q series extension cable is connected here. When no cable is connected, attach the supplied extension connector cover to prevent entry of foreign matter such as dust.
(3)	Extension connector cover	A protective cover for the extension cable connector
(4)	Module connector	A connector for mounting MELSEC-Q series modules. The CPU module cannot be mounted on an extension base unit. Attach a blank cover module (QG60) to a connector where no module is mounted to prevent entry of foreign matter such as dust.
(5)	Module fixing hole	A screw hole to fix a module to the base unit (M3×12 screw)
(6)	Base unit installation hole	A hole to install a base unit to a control panel (M4 screw)
(7)	DIN rail adapter mounting hole	A hole to mount a DIN rail adapter
(8)	Production information marking	Shows the production information (16 digits) of the module.
(9)	10m mark	Indicates that the base unit supports the ten-meter extension cable (RC100B).

3.3 SD Memory Card

This section describes the part names of the SD memory card. (The NZ1MEM-16GBSD is used as an example.)

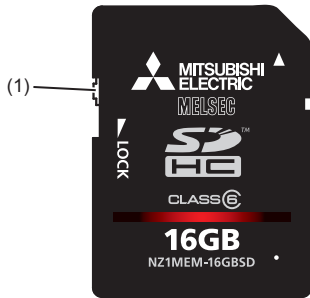

No.	Name	Description
(1)	Write protect switch	Prevents the data in the card from being erased or modified by setting this switch to the LOCK position.

4 SPECIFICATIONS

4.1 General Specifications

This chapter describes the general specifications of the modules used.

Item	Specifications					
Operating ambient temperature	0 to 55°C (When an extended temperature range base unit is not used)					
	0 to 60°C ^{*6} (When an extended temperature range base unit is used)					
Storage ambient temperature	-25 to 75°C					
Operating ambient humidity	5 to 95%RH, non-condensing					
Storage ambient humidity	5 to 95%RH, non-condensing					
Vibration resistance	—	Frequency	Constant acceleration	Half amplitude	Sweep count	IEC 61131-2: 2007/JIS B 3502: 2011
	Under intermittent vibration	5 to 8.4Hz	—	3.5mm	10 times each in X, Y, and Z directions	
		8.4 to 150Hz	9.8m/s ²	—		
	Under continuous vibration	5 to 8.4Hz	—	1.75mm	—	
8.4 to 150Hz		4.9m/s ²	—			
Shock resistance	Three shocks in each direction per axis, on 3 mutually perpendicular axes (total of 18 shocks)					
Operating atmosphere	No corrosive gases ^{*4} , flammable gases, less conductive dust					
Operating altitude ^{*1}	0 to 2000m ^{*5}					
Installation location	Inside a control panel (Indoor use)					
Overvoltage category ^{*2}	II or less					
Pollution degree ^{*3}	2 or less					

- *1 Do not use or store the programmable controller under pressure higher than the atmospheric pressure of altitude 0m. Doing so may cause malfunction. When using the programmable controller under pressure, please consult your local Mitsubishi representative.
- *2 This indicates the section of the power supply to which the equipment is assumed to be connected between the public electrical power distribution network and the machinery within premises. Category II applies to equipment for which electrical power is supplied from fixed facilities. The surge voltage withstand level for up to the rated voltage of 300V is 2500V.
- *3 This index indicates the degree to which conductive material is generated in terms of the environment in which the equipment is used. Pollution degree 2 is when only non-conductive pollution occurs. A temporary conductivity caused by condensing must be expected occasionally.
- *4 When using the programmable controller in the environment with the corrosive gases, use the special coated products having improved resistance to the environment of a certain degree of corrosive gas concentration specified in IEC 60721-3-3:1994 3C2. For details on the special coated products, please consult your local Mitsubishi representative.
- *5 When the programmable controller is used at altitude above 2000m, the withstand voltage performance and the upper limit of the operating ambient temperature decrease. Please consult your local Mitsubishi representative.
- *6 All modules mounted on the extended temperature range base unit provide the same performance as that for an operating ambient temperature of 0 to 55°C, even though they are used in an operating ambient temperature of 0 to 60°C. When using the modules in the environment of the temperature exceeding 60°C, please consult your local Mitsubishi representative.

4.2 Performance Specifications of Power Supply Module

This section describes the performance specifications of the power supply module.

Item		AC input power supply module					DC input power supply module			
		R61P	R61SP	R62P	R64P	R64RP	R63P	R63RP	R69P	R69RP
Input power supply voltage		100 to 240VAC (85 to 264VAC)					24VDC (15.6 to 31.2VDC)	24VDC (19.2 to 31.2VDC)		
Input frequency		50/60Hz±5%					—			
Input voltage distortion factor		Within 5%					—			
Maximum input apparent power		130VA	45VA	120VA	160VA	—				
Maximum input power		—					50W	65W		
Inrush current		20A, 8ms or less	40A, 8ms or less	20A, 8ms or less		100A, 1ms or less (24VDC input)				
Rated output current	5VDC	6.5A	2.5A	3.5A	9A	6.5A		9A		
	24VDC	—	—	0.6A	—	—				
Overcurrent protection	5VDC	7.1A or higher	2.8A or higher	3.8A or higher	10.0A or higher	7.1A or higher		10.0A or higher		
	24VDC	—	—	0.66A or higher	—	—				
Overvoltage protection	5VDC	5.5 to 6.5V								
Efficiency		76% or more	70% or more	76% or more		70% or more		75% or more		
Allowable momentary power failure time		Within 20ms					Within 10ms (24VDC input) ^{*1}			
Withstand voltage		2300VAC rms per minute (altitude 0 to 2000m), Between the combined "line input/LG terminals" and the "FG terminal and output"	3000VAC rms per minute (altitude 0 to 2000m), Between the combined "line input/LG terminals" and the "FG terminal and output"	2300VACrms per minute (altitude 0 to 2000m), Between the combined "line input/LG terminals" and the "FG terminal and output"		510VAC per minute (altitude 0 to 2000m), Between the combined "line input/LG terminals" and the "FG terminal and output"				
Insulation resistance		10MΩ or higher by 500VDC insulation resistance tester (between the combined "line input/LG terminals" and the "FG terminal and output", the line input and LG terminals, the output and FG terminals)								
Noise immunity		<ul style="list-style-type: none"> Noise voltage 1500Vp-p, noise width 1μs, noise frequency 25 to 60Hz (noise simulator condition) Noise immunity test IEC 61000-4-4: 2kV 				Noise voltage 500Vp-p, noise width 1μs, noise frequency 25 to 60Hz (noise simulator condition)				
Fuse		Built-in (user-unchangeable)								

Item		AC input power supply module					DC input power supply module			
		R61P	R61SP	R62P	R64P	R64RP	R63P	R63RP	R69P	R69RP
Contact output section	Application	ERR contact								
	Rated switching voltage/current	24VDC, 0.5A								
	Minimum switching load	5VDC, 1mA								
	Response time	Off→on: 10ms or less On→off: 12ms or less								
	Life	Mechanical: 20 million times or more Electrical: Rated switching voltage/current, 100 thousand times or more								
	Surge suppressor	None								
	Fuse	None								
Terminal screw size		M4 (M3.5 for +24V and 24G terminals of the R61SP and R62P)								
Applicable wire size		0.75 to 2mm ²								
Applicable solderless terminal		RAV1.25-4, RAV2-4, thickness of 0.8mm or less, up to two solderless terminal connections per terminal (for the +24V and 24G terminals of the R61SP and R62P: RAV1.25-3.5, RAV2-3.5, thickness of 0.8mm or less, up to two solderless terminal connections per terminal)								
Applicable tightening torque		M4 screw: 1.02 to 1.38N·m M3.5 screw: 0.66 to 0.89N·m								
External dimensions	Height	106mm (Base unit mounting side: 98mm)								
	Width	54.6mm	27.8mm	54.6mm						
	Depth	110mm	123mm	110mm						
Weight		0.41kg	0.20kg	0.45kg	0.46kg	0.41kg		0.46kg		

*1 It will be shorter than 10ms if the input voltage is lower than 24VDC.

Detailed explanation of items

■Input power supply voltage

Input power supply voltage is a voltage required for the power supply module to operate normally. If the voltage is out of the specified range, an error is detected and the system may stop.

■Inrush current

Inrush current is the maximum, instantaneous input current drawn into the circuits immediately after power-on.

If power is supplied to the system immediately after shut-off, an inrush current of more than the specified value may flow.

Wait for five seconds or more after shut-off, and supply power to the system again.

When selecting a fuse or a breaker for the external circuit, consider blowouts, sensing property, and specified value of inrush current.

■Overcurrent protection

The function of this protection is to shut off the circuit to stop the system if a current exceeding the specification value flows into a circuit of 5VDC or 24VDC.

With overcurrent protection activated, the LED of the power supply module goes off or lights dim green due to a voltage drop.

To restart the system, shut off the power and eliminate the cause of the problem, such as insufficient current or short-circuit.

After the cause is eliminated, wait for a few minutes, and supply power to the system again. The time required to clear the overcurrent protection differs depending on models. If the restart time is short, the overcurrent protection may not be cleared, preventing the system from starting. If the output current is back to normal, the system starts initially.

■Overvoltage protection

The function of this protection is to shut off the circuit to stop the system if an overvoltage exceeding the specified value is applied to a 5VDC circuit.

With overvoltage protection activated, the POWER LED of the power supply module turns off.

To restart the system, shut off the power and eliminate the cause of overvoltage. After the cause is eliminated, wait for a few minutes, and supply power to the system again. The time required to clear the overvoltage protection differs depending on models. If the restart time is short, the overvoltage protection may not be cleared, preventing the system from starting. When the system does not restart and the POWER LED remains off even after power is supplied to the system again, replace the power supply module.

■ Allowable momentary power failure time

The system detects an input voltage down and stops its operation when a momentary power failure occurs. Allowable momentary power failure time is a period of time that the system can continue its operation even after the power failure. If power fails exceeding this period of time, the system can either continue its operation or start initially, depending on the load of the power supply module. When the system continues its operation, the operation will be the same as that of the system returned within the allowable momentary power failure time.

Selecting the power supply module

The power supply module should be selected in accordance with the total current consumption of the power supply target base unit and each module.

Select the power supply module so that the current consumption of the base unit does not exceed the rated output current of the power supply module mounted on the base unit.

For the internal current consumption (5VDC) of the base unit and CPU module, refer to the following.

- Base unit (📖 Page 141 Performance Specifications of Base Unit)
- CPU module (📖 MELSEC iQ-R CPU Module User's Manual (Startup))

For the internal current consumption (5VDC) of each module, refer to the manual for the module used.

For devices obtained by a user, such as an external power supply (24VDC) and breaker, refer to the manual for the device used.

■When a redundant power supply system is configured

If one redundant power supply module failed, only the other redundant power supply module continues the operation.

Therefore, keep the current consumption of the redundant power supply base unit within the rated output current for one redundant power supply module.

When two modules out of the R69RP, the R64RP, and the R63RP, adapt the smaller rated output current value in the system.

For example, when the R64RP and the R63RP are used, the rated output current of the R64RP is 9A and the rated output current of the R63RP is 6.5A. Therefore, keep the current consumption less than 6.5A. When the R69RP and the R64RP are used, keep the current consumption less than 9A because both of the rated output currents are 9A.

■When MELSEC-Q series modules are connected

Select the power supply module so that the current consumption of each extension base unit does not exceed the rated output current of the power supply module mounted on each extension base unit.

When the extension base unit (type requiring no power supply module) (Q5□B) is used, 5VDC is supplied from the power supply module mounted on the RQ extension base unit. Select the power supply module so that the total current consumption of the modules on the RQ extension base unit and the Q5□B does not exceed the rated output current of the power supply module mounted on the RQ extension base unit. (📖 Page 98 Consideration for internal current consumption)

Point

The current consumption can be checked in "Power Supply Capacity and I/O Points" of the engineering tool.

4.3 Performance Specifications of Base Unit

This section describes the performance specifications of the base unit.

Main base unit

Item	R33B	R35B	R38B	R312B	
Number of mountable I/O modules	3	5	8	12	
DIN rail adapter model	R6DIN1				
Internal current consumption (5VDC)	0.46A	0.58A	0.71A	0.88A	
Mounting hole size	M4 screw hole or Φ 4.5 hole (for M4 screw)				
External dimensions	Height	101mm			
	Width	189mm	245mm	328mm	439mm
	Depth	32.5mm			
Weight	0.31kg	0.41kg	0.55kg	0.72kg	

Slim type main base unit

Item	R32SB	R33SB	R35SB	
Number of mountable I/O modules	2	3	5	
DIN rail adapter model	R6DIN1			
Internal current consumption (5VDC)	0.35A	0.39A	0.45A	
Mounting hole size	M4 screw hole or Φ 4.5 hole (for M4 screw)			
External dimensions	Height	101mm		
	Width	114mm	142mm	198.5mm
	Depth	32.5mm		
Weight	0.18kg	0.23kg	0.32kg	

Extended temperature range main base unit

Item	R310B-HT	
Number of mountable I/O modules	10	
DIN rail adapter model	R6DIN1	
Internal current consumption (5VDC)	0.82A	
Mounting hole size	M4 screw hole or Φ 4.5 hole (for M4 screw)	
External dimensions	Height	101mm
	Width	439mm
	Depth	32.5mm
Weight	0.69kg	

Redundant power supply main base unit

Item		R310RB
Number of mountable I/O modules		10
DIN rail adapter model		R6DIN1
Internal current consumption (5VDC)		0.91A
Mounting hole size		M4 screw hole or Φ 4.5 hole (for M4 screw)
External dimensions	Height	101mm
	Width	439mm
	Depth	32.5mm
Weight		0.73kg

Extended temperature range redundant power supply main base unit

Item	R38RB-HT	
Number of mountable I/O modules	8	
DIN rail adapter model	R6DIN1	
Internal current consumption (5VDC)	0.86A	
Mounting hole size	M4 screw hole or Φ 4.5 hole (for M4 screw)	
External dimensions	Height	101mm
	Width	439mm
	Depth	32.5mm
Weight	0.72kg	

Extension base unit

Item	R65B	R68B	R612B	
Number of mountable I/O modules	5	8	12	
DIN rail adapter model	R6DIN1			
Internal current consumption (5VDC)	0.70A	0.81A	0.92A	
Mounting hole size	M4 screw hole or Φ 4.5 hole (for M4 screw)			
External dimensions	Height	101mm		
	Width	245mm	328mm	439mm
	Depth	32.5mm		
Weight	0.41kg	0.55kg	0.73kg	

Extended temperature range extension base unit

Item	R610B-HT	
Number of mountable I/O modules	10	
DIN rail adapter model	R6DIN1	
Internal current consumption (5VDC)	0.85A	
Mounting hole size	M4 screw hole or Φ 4.5 hole (for M4 screw)	
External dimensions	Height	101mm
	Width	439mm
	Depth	32.5mm
Weight	0.72kg	

Redundant power supply extension base unit

Item	R610RB	
Number of mountable I/O modules	10	
DIN rail adapter model	R6DIN1	
Internal current consumption (5VDC)	0.97A	
Mounting hole size	M4 screw hole or Φ 4.5 hole (for M4 screw)	
External dimensions	Height	101mm
	Width	439mm
	Depth	32.5mm
Weight	0.73kg	

Extended temperature range redundant power supply extension base unit

Item		R68RB-HT
Number of mountable I/O modules		8
DIN rail adapter model		R6DIN1
Internal current consumption (5VDC)		0.93A
Mounting hole size		M4 screw hole or Φ 4.5 hole (for M4 screw)
External dimensions	Height	101mm
	Width	439mm
	Depth	32.5mm
Weight		0.72kg

Redundant extension base unit

Item		R68WRB
Number of mountable I/O modules		8
DIN rail adapter model		R6DIN1
Internal current consumption (5VDC)		1.50A
Mounting hole size		M4 screw hole or Φ 4.5 hole (for M4 screw)
External dimensions	Height	101mm
	Width	439mm
	Depth	32.5mm
Weight		0.76kg

Extended temperature range redundant extension base unit

Item		R66WRB-HT
Number of mountable I/O modules		6
DIN rail adapter model		R6DIN1
Internal current consumption (5VDC)		1.35A
Mounting hole size		M4 screw hole or Φ 4.5 hole (for M4 screw)
External dimensions	Height	101mm
	Width	439mm
	Depth	32.5mm
Weight		0.76kg

Extension cable

Item	RC06B	RC12B	RC30B	RC50B	RC100B
Length	0.6m	1.2m	3.0m	5.0m	10.0m
Weight	0.15kg	0.22kg	0.40kg	0.60kg	1.2kg



The ten-meter extension cable (RC100B) can be used only with a base unit having the 10m mark on it. Check that the 10m mark is printed on the extension connector cover of the base unit to be connected before using the ten-meter extension cable. (☞ Page 131 Base Unit).

RQ extension base unit (for MELSEC-Q series modules)

Item	RQ65B	RQ68B	RQ612B	
Number of mountable I/O modules	5	8	12	
DIN rail adapter model	Q6DIN2	Q6DIN1		
Internal current consumption (5VDC)	0.28A	0.31A	0.32A	
Mounting hole size	M4 screw hole or Φ 4.5 hole (for M4 screw)			
External dimensions	Height	98mm		
	Width	245mm	328mm	439mm
	Depth	44.1mm		
Weight	0.32kg	0.41kg	0.55kg	

For the specifications of MELSEC-Q series extension cables, refer to the following.

 QCPU User's Manual (Hardware Design, Maintenance and Inspection)

4.4 Performance Specifications of SD Memory Card

This section describes the performance specifications of the SD memory card.

Item	NZ1MEM-2GBSD	NZ1MEM-4GBSD	NZ1MEM-8GBSD	NZ1MEM-16GBSD
Type	SD	SDHC		
Capacity	2G bytes	4G bytes	8G bytes	16G bytes
Number of writes	60000 times	100000 times		
External dimensions	Height	32mm		
	Width	24mm		
	Depth	2.1mm		
Weight	2g			

For the performance specifications of the L1MEM-2GBSD and L1MEM-4GBSD, refer to the following.

 QCPU User's Manual (Hardware Design, Maintenance and Inspection)

When using an SD memory card in a C Controller module, refer to the following.

 MELSEC iQ-R C Controller Module User's Manual

When using an SD memory card in a MELSECWinCPU module, refer to the following.

 MELSEC iQ-R MELSECWinCPU Module User's Manual

Handling precautions

- The operation of the SD memory cards manufactured by Mitsubishi Electric (NZ1MEM-□GBSD) has been tested on the MELSEC iQ-R series modules. If an SD memory card*¹ manufactured by other companies is used, a problem, such as damage to data in the SD memory card and system operation stop, may occur.
- SD memory cards manufactured by Mitsubishi Electric conform to IEC 61131-2 when being used in a module.
- SDHC memory cards can be used only with CPU modules that are compatible with them. (An SDHC logo is shown on the module or the support is described in the manual.) Note that SDHC memory cards cannot be used with the CPU modules that are compatible with SD only.
- All SD memory cards to be used in the CPU module need to be formatted. SD memory cards manufactured by Mitsubishi Electric are already formatted at the factory. When using other SD memory cards that are not formatted, format the cards before use.
- Use the engineering tool to format SD memory cards. (Do not use a personal computer.) ( GX Works3 Operating Manual)
- Data in the SD memory card may corrupt if the following operation is performed while the SD memory card is being accessed: powering off the system, resetting the CPU module, or removing the SD memory card. When the CARD ACCESS LED is on, terminate the access to the SD memory card with the SD CARD OFF button, and then power off the system, reset the CPU module, or remove the SD memory card. The use of the SD memory card can be disabled by SM606 (SD memory card forced disable instruction) and the disabled status can be checked by SM607 (SD memory card forced disable status flag).
- Regularly make a backup of important data on the SD memory card to other media, such as CDs and DVDs.

*1 If commercially available SD memory cards are used, operation under the environment described in Page 136 General Specifications is not guaranteed. Ensure that such SD memory cards will not cause system control problems.

Precautions

If the system is powered off, the CPU module is reset, or the SD memory card is removed while the SD memory card is being accessed as below, data in the SD memory card may corrupt.

- Data in the buffer memory is being saved to the SD memory card. (Data logging function is being executed.)
- During the folder delete by "User Data Operation" in the engineering tool

In the above case, the SD memory card diagnostics such as the file system check and restoration is performed at powering off and on the system or the reset clear.

Note that the data may be not restored because of the file system status.

The following time is required to diagnose the SD memory card. If there is any concern about the influence on the system, please do not use an SD memory card.*1*2

Conditions	SD memory card	Time required for SD memory card diagnostics
When 10000 files (100K bytes) are stored in the SD memory card and fragmentation has not occurred	NZ1MEM-2GBSD	Approximately 7 seconds
	NZ1MEM-4GBSD	Approximately 8 seconds
	NZ1MEM-8GBSD	Approximately 9 seconds
	NZ1MEM-16GBSD	Approximately 10 seconds
When 8000 folders are stored in the SD memory card and fragmentation has not occurred	NZ1MEM-2GBSD	Approximately 17 minutes
	NZ1MEM-4GBSD	Approximately 18 minutes
	NZ1MEM-8GBSD	Approximately 18 minutes
	NZ1MEM-16GBSD	Approximately 18 minutes

*1 If there are many files or folders on the SD memory card, the diagnostics may take an excessively long time, potentially more than 10 minutes, before the CPU module starts running. Depending on the usage status (conditions such as deterioration due to aging) and the manufacturer of the SD memory card, the diagnostics may take a long time even if the number of stored files or folders is relatively small.

*2 When the CPU module is in connection with an external device, running the CPU module and the external device simultaneously can cause communication time-out on the external device side.

4.5 Performance Specifications of CFast Card

This section describes the performance specifications of the CFast card.

Item	NZ1MEM-16GBCFT	NZ1MEM-32GBCFT	NZ1MEM-64GBCFT
Interface	Serial ATA 3.0Gbps		
Capacity	16G bytes	32G bytes	64G bytes
Number of writes	10000 times		
External dimensions	Height	36.4mm	
	Width	42.8mm	
	Depth	3.3mm	
Weight	10g		

Handling precautions

- The operation of the CFast cards manufactured by Mitsubishi Electric (NZ1MEM-□GBCFT) has been tested on the MELSEC iQ-R series modules. If a CFast card^{*1} manufactured by other companies is used, a problem, such as damage to data in the CFast card and system operation stop, may occur.
- CFast cards manufactured by Mitsubishi Electric conform to IEC 61131-2 when being used in a module.
- All CFast cards to be used in the CPU module need to be formatted. Note that CFast cards manufactured by Mitsubishi Electric are not formatted at the factory. Therefore, ensure to format a CFast card before use.
- Data in a CFast card may corrupt if any of the following operations is performed while the CFast card is being accessed: powering off the system, resetting the hardware of a MELSECWinCPU module, restarting Windows forcibly, or removing the CFast card. Terminate the access to the CFast card, and then power off the system, reset the hardware, restart Windows forcibly, or remove the CFast card.
- Power off a module before inserting or removing a CFast card.
- Regularly make a backup of important data on the CFast card to other media, such as CDs and DVDs.

*1 If commercially available CFast cards are used, operation under the environment described in Page 136 General Specifications is not guaranteed. Ensure that such CFast cards will not cause system control problems.

4.6 Performance Specifications of Battery

This section describes the performance specifications of the battery used for the CPU module.

Item	Q6BAT	Q7BATN ^{*1}	Q7BAT ^{*1}
Type	Manganese dioxide lithium primary battery		
Initial voltage	3.0V		
Nominal current	1800mAh	6000mAh	5000mAh
Battery life when not used	Approximately 5 years (room temperature)		
Lithium content	0.57g ^{*2}	1.80g	1.55g

*1 The Q7BATN-SET and Q7BAT-SET include a battery holder. Note that the battery holder for the Q7BAT cannot be used for the Q7BATN.

*2 The lithium content of batteries manufactured in July 2017 or earlier differs. For details, refer to the following.

📖 Changes in battery parts (FA-A-0242)

For the FX3U-32BL, refer to the following.

📖 FX3U-32BL Battery

Application

A battery is used as the backup power for the device/label for which the latches are enabled and clock data. (📖 MELSEC iQ-R CPU Module User's Manual (Application))

Battery life

There are two types of values for describing a battery life: actual service value and guaranteed value.

- Actual service value: Refers to the battery life estimated based on the value actually measured by Mitsubishi under a storage ambient temperature of 40°C. This value varies depending on the characteristics and variation of the components, and should be referred to as a reference value.
- Guaranteed value: Refers to the battery life at 70°C guaranteed by Mitsubishi in a storage ambient temperature of 70°C based on the characteristics of the memory device provided by the component manufacturer.

Q6BAT, Q7BATN, Q7BAT

■ When used in a programmable controller CPU (except for the R00CPU, R01CPU, or R02CPU)

The actual service values and guaranteed values are as follows:

- Actual service value (reference value)

Extended SRAM cassette	Power-on time ratio ^{*1}	Actual service value when used in the R04CPU or R04ENCPU			Actual service value when used in the R08CPU, R08ENCPU, R16CPU, R16ENCPU, R32CPU, R32ENCPU, R120CPU, or R120ENCPU		
		Q6BAT	Q7BATN	Q7BAT	Q6BAT	Q7BATN	Q7BAT
Not used, used (1MB type), used (2MB type), used (4MB type), used (8MB type)	0 to 100%	43800 hours (5.00 years)	43800 hours (5.00 years)	43800 hours (5.00 years)	43800 hours (5.00 years)	43800 hours (5.00 years)	43800 hours (5.00 years)
	Used (16MB type) ^{*2}				25500 hours (2.91 years)		
	0%	30100 hours (3.43 years)			36400 hours (4.15 years)		
	30%	43000 hours (4.90 years)			43800 hours (5.00 years)		
	50 to 100%	43800 hours (5.00 years)					

• Guaranteed value

Extended SRAM cassette	Power-on time ratio *1	Guaranteed value when used in the R04CPU or R04ENCPU			Guaranteed value when used in the R08CPU, R08ENCPU, R16CPU, R16ENCPU, R32CPU, R32ENCPU, R120CPU, or R120ENCPU		
		Q6BAT	Q7BATN	Q7BAT	Q6BAT	Q7BATN	Q7BAT
Not used	0%	31700 hours (3.61 years)	43800 hours (5.00 years)	43800 hours (5.00 years)	30600 hours (3.49 years)	43800 hours (5.00 years)	43800 hours (5.00 years)
	30%	43800 hours (5.00 years)			43700 hours (4.98 years)		
	50 to 100%				43800 hours (5.00 years)		
Used (1MB type)	0%	22000 hours (2.51 years)			21500 hours (2.45 years)		
	30%	31400 hours (3.58 years)			30700 hours (3.50 years)		
	50%	43800 hours (5.00 years)			43000 hours (4.90 years)		
	70 to 100%				43800 hours (5.00 years)		
Used (2MB type)	0%	19600 hours (2.23 years)			19100 hours (2.18 years)		43100 hours (4.92 years)
	30%	28000 hours (3.19 years)			27200 hours (3.10 years)		43800 hours (5.00 years)
	50%	39200 hours (4.47 years)			38200 hours (4.36 years)		
	70 to 100%	43800 hours (5.00 years)			43800 hours (5.00 years)		
Used (4MB type)	0%	15300 hours (1.74 years)	40550 hours (4.63 years)	39600 hours (4.52 years)	15000 hours (1.71 years)	39640 hours (4.53 years)	36200 hours (4.13 years)
	30%	21800 hours (2.48 years)	43800 hours (5.00 years)	43800 hours (5.00 years)	21400 hours (2.44 years)	43800 hours (5.00 years)	43800 hours (5.00 years)
	50%	30600 hours (3.49 years)			30000 hours (3.42 years)		
	70 to 100%	43800 hours (5.00 years)			43800 hours (5.00 years)		
Used (8MB type)	0%	10100 hours (1.15 years)	29822 hours (3.40 years)	26900 hours (3.07 years)	10000 hours (1.14 years)	29591 hours (3.38 years)	24800 hours (2.83 years)
	30%	14400 hours (1.64 years)	42604 hours (4.86 years)	38400 hours (4.38 years)	14200 hours (1.62 years)	42272 hours (4.83 years)	35400 hours (4.04 years)
	50%	20200 hours (2.30 years)	43800 hours (5.00 years)	43800 hours (5.00 years)	20000 hours (2.28 years)	43800 hours (5.00 years)	43800 hours (5.00 years)
	70%	33600 hours (3.83 years)			33300 hours (3.80 years)		
	100%	43800 hours (5.00 years)			43800 hours (5.00 years)		
Used (16MB type)*2	0%	6400 hours (0.73 years)	18853 hours (2.15 years)	16100 hours (1.83 years)	6400 hours (0.73 years)	18861 hours (2.15 years)	16000 hours (1.82 years)
	30%	9100 hours (1.03 years)	26933 hours (3.07 years)	23000 hours (2.62 years)	9100 hours (1.03 years)	26945 hours (3.08 years)	22800 hours (2.62 years)
	50%	12800 hours (1.46 years)	37706 hours (4.30 years)	32200 hours (3.67 years)	12800 hours (1.46 years)	37722 hours (4.31 years)	32000 hours (3.65 years)
	70%	21300 hours (2.43 years)	43800 hours (5.00 years)	43800 hours (5.00 years)	21300 hours (2.43 years)	43800 hours (5.00 years)	43800 hours (5.00 years)
	100%	43800 hours (5.00 years)			43800 hours (5.00 years)		

*1 The power-on time ratio indicates the ratio of the programmable controller power-on time to 24 hours. (If the total power-on time is 12 hours, the ratio will be 50%. If the total power-on time is 6 hours, the ratio will be 25%.)

*2 Check the versions of the CPU module and engineering tool used. (MELSEC iQ-R CPU Module User's Manual (Application))

■When used in a Process CPU

The actual service values and guaranteed values are as follows:

- Actual service value (reference value)

Extended SRAM cassette	Power-on time ratio*1	Actual service value when used in the R08PCPU or R16PCPU			Actual service value when used in the R32PCPU or R120PCPU		
		Q6BAT	Q7BATN	Q7BAT	Q6BAT	Q7BATN	Q7BAT
Not used	0 to 100%	43800 hours (5.00 years)	43800 hours (5.00 years)	43800 hours (5.00 years)	43800 hours (5.00 years)	43800 hours (5.00 years)	43800 hours (5.00 years)
Used (ECC-compatible 2MB type)	0%	43300 hours (4.94 years)			40200 hours (4.58 years)		
	30%	43800 hours (5.00 years)			43800 hours (5.00 years)		
	50%						
	70%						
Used (ECC-compatible 8MB type)	0%	24000 hours (2.73 years)			23000 hours (2.62 years)		
	30%	34200 hours (3.90 years)			32800 hours (3.74 years)		
	50 to 100%	43800 hours (5.00 years)			43800 hours (5.00 years)		

- Guaranteed value

Extended SRAM cassette	Power-on time ratio*1	Guaranteed value when used in the R08PCPU or R16PCPU			Guaranteed value when used in the R32PCPU or R120PCPU			
		Q6BAT	Q7BATN	Q7BAT	Q6BAT	Q7BATN	Q7BAT	
Not used	0%	24400 hours (2.78 years)	43800 hours (5.00 years)	43800 hours (5.00 years)	17300 hours (1.97 years)	42083 hours (4.80 years)	39900 hours (4.55 years)	
	30%	34800 hours (3.97 years)			24700 hours (2.81 years)			
	50%	43800 hours (5.00 years)			34600 hours (3.94 years)			
	70 to 100%				43800 hours (5.00 years)			
Used (ECC-compatible 2MB type)	0%	13300 hours (1.51 years)	43800 hours (5.00 years)	33300 hours (3.80 years)	10800 hours (1.23 years)	37600 hours (4.29 years)	27000 hours (3.08 years)	
	30%	19000 hours (2.16 years)			43800 hours (5.00 years)			15400 hours (1.75 years)
	50%	26600 hours (3.03 years)						21600 hours (2.46 years)
	70%	43800 hours (5.00 years)						36000 hours (4.10 years)
	100%							43800 hours (5.00 years)
Used (ECC-compatible 8MB type)	0%	6100 hours (0.69 years)	18462 hours (2.11 years)	15100 hours (1.72 years)	5500 hours (0.62 years)	16835 hours (1.92 years)	13700 hours (1.56 years)	
	30%	8700 hours (0.99 years)	26374 hours (3.01 years)	21500 hours (2.45 years)	7800 hours (0.89 years)	24051 hours (2.75 years)	19500 hours (2.22 years)	
	50%	12200 hours (1.39 years)	36923 hours (4.21 years)	30200 hours (3.44 years)	11000 hours (1.25 years)	33671 hours (3.84 years)	27400 hours (3.12 years)	
	70%	20300 hours (2.31 years)	43800 hours (5.00 years)	43800 hours (5.00 years)	18300 hours (2.08 years)	43800 hours (5.00 years)	43800 hours (5.00 years)	
	100%	43800 hours (5.00 years)			43800 hours (5.00 years)			

*1 The power-on time ratio indicates the ratio of the programmable controller power-on time to 24 hours. (If the total power-on time is 12 hours, the ratio will be 50%. If the total power-on time is 6 hours, the ratio will be 25%.)

■When used in a SIL2 Process CPU

The actual service values and guaranteed values are as follows:

- Actual service value (reference value)

Extended SRAM cassette	Power-on time ratio*1	Actual service value when used in the R08PSFCPU or R16PSFCPU			Actual service value when used in the R32PSFCPU or R120PSFCPU		
		Q6BAT	Q7BATN	Q7BAT	Q6BAT	Q7BATN	Q7BAT
Not used	0 to 100%	43800 hours (5.00 years)	43800 hours (5.00 years)	43800 hours (5.00 years)	43800 hours (5.00 years)	43800 hours (5.00 years)	43800 hours (5.00 years)
Used (ECC-compatible 2MB type)*2	0%	43300 hours (4.94 years)			40200 hours (4.58 years)		
	30%	43800 hours (5.00 years)			43800 hours (5.00 years)		
	50%						
	70%						
Used (ECC-compatible 8MB type)	0%	24000 hours (2.73 years)			23000 hours (2.62 years)		
	30%	34200 hours (3.90 years)			32800 hours (3.74 years)		
	50 to 100%	43800 hours (5.00 years)			43800 hours (5.00 years)		

- Guaranteed value

Extended SRAM cassette	Power-on time ratio*1	Guaranteed value when used in the R08PSFCPU or R16PSFCPU			Guaranteed value when used in the R32PSFCPU or R120PSFCPU			
		Q6BAT	Q7BATN	Q7BAT	Q6BAT	Q7BATN	Q7BAT	
Not used	0%	24400 hours (2.78 years)	43800 hours (5.00 years)	43800 hours (5.00 years)	17300 hours (1.97 years)	42083 hours (4.80 years)	39900 hours (4.55 years)	
	30%	34800 hours (3.97 years)			24700 hours (2.81 years)			43800 hours (5.00 years)
	50%	43800 hours (5.00 years)			34600 hours (3.94 years)			
	70 to 100%				43800 hours (5.00 years)			
Used (ECC-compatible 2MB type)*2	0%	13300 hours (1.51 years)		33300 hours (3.80 years)	10800 hours (1.23 years)	37600 hours (4.29 years)	27000 hours (3.08 years)	
	30%	19000 hours (2.16 years)		43800 hours (5.00 years)	15400 hours (1.75 years)	43800 hours (5.00 years)	38500 hours (4.39 years)	
	50%	26600 hours (3.03 years)			21600 hours (2.46 years)		43800 hours (5.00 years)	
	70%	43800 hours (5.00 years)			36000 hours (4.10 years)			
	100%				43800 hours (5.00 years)			
Used (ECC-compatible 8MB type)	0%	6100 hours (0.69 years)	18462 hours (2.11 years)	15100 hours (1.72 years)	5500 hours (0.62 years)	16835 hours (1.92 years)	13700 hours (1.56 years)	
	30%	8700 hours (0.99 years)	26374 hours (3.01 years)	21500 hours (2.45 years)	7800 hours (0.89 years)	24051 hours (2.75 years)	19500 hours (2.22 years)	
	50%	12200 hours (1.39 years)	36923 hours (4.21 years)	30200 hours (3.44 years)	11000 hours (1.25 years)	33671 hours (3.84 years)	27400 hours (3.12 years)	
	70%	20300 hours (2.31 years)	43800 hours (5.00 years)	43800 hours (5.00 years)	18300 hours (2.08 years)	43800 hours (5.00 years)	43800 hours (5.00 years)	
	100%	43800 hours (5.00 years)			43800 hours (5.00 years)			

*1 The power-on time ratio indicates the ratio of the programmable controller power-on time to 24 hours. (If the total power-on time is 12 hours, the ratio will be 50%. If the total power-on time is 6 hours, the ratio will be 25%.)

*2 Check the version of the engineering tool used. (MELSEC iQ-R CPU Module User's Manual (Application))

■When used in a Safety CPU

The actual service values and guaranteed values are as follows:

- Actual service value (reference value)

Extended SRAM cassette	Power-on time ratio*1	Actual service value when used in the R08SF CPU or R16SF CPU			Actual service value when used in the R32SF CPU or R120SF CPU		
		Q6BAT	Q7BATN	Q7BAT	Q6BAT	Q7BATN	Q7BAT
Not used, used (1MB type), used (2MB type)	0 to 100%	43800 hours (5.00 years)	43800 hours (5.00 years)	43800 hours (5.00 years)	43800 hours (5.00 years)	43800 hours (5.00 years)	43800 hours (5.00 years)
Used (4MB type)	0%				42200 hours (4.81 years)		
	30 to 100%				43800 hours (5.00 years)		
Used (8MB type)	0%	33700 hours (3.84 years)			31700 hours (3.61 years)		
	30 to 100%	43800 hours (5.00 years)			43800 hours (5.00 years)		
Used (ECC-compatible 2MB type)	0%	43300 hours (4.94 years)			40200 hours (4.58 years)		
	30%	43800 hours (5.00 years)			43800 hours (5.00 years)		
	50%						
	70%						
100%							
Used (ECC-compatible 8MB type)	0%	24000 hours (2.73 years)			23000 hours (2.62 years)		
	30%	34200 hours (3.90 years)			32800 hours (3.74 years)		
	50 to 100%	43800 hours (5.00 years)			43800 hours (5.00 years)		

- Guaranteed value

Extended SRAM cassette	Power-on time ratio*1	Guaranteed value when used in the R08SF CPU or R16SF CPU			Guaranteed value when used in the R32SF CPU or R120SF CPU			
		Q6BAT	Q7BATN	Q7BAT	Q6BAT	Q7BATN	Q7BAT	
Not used	0%	24400 hours (2.78 years)	43800 hours (5.00 years)	43800 hours (5.00 years)	17300 hours (1.97 years)	42083 hours (4.80 years)	39900 hours (4.55 years)	
	30%	34800 hours (3.97 years)			24700 hours (2.81 years)			43800 hours (5.00 years)
	50%	43800 hours (5.00 years)			34600 hours (3.94 years)			
	70 to 100%				43800 hours (5.00 years)			
Used (1MB type)	0%	18100 hours (2.06 years)	43516 hours (4.97 years)	41500 hours (4.73 years)	13900 hours (1.58 years)	38678 hours (4.42 years)	34200 hours (3.90 years)	
	30%	25800 hours (2.94 years)			19800 hours (2.26 years)			
	50%	36200 hours (4.13 years)			27800 hours (3.17 years)			
	70 to 100%	43800 hours (5.00 years)			43800 hours (5.00 years)			
Used (2MB type)	0%	16400 hours (1.87 years)	42178 hours (4.81 years)	38500 hours (4.39 years)	12900 hours (1.47 years)	36641 hours (4.18 years)	32000 hours (3.65 years)	
	30%	23400 hours (2.67 years)			18400 hours (2.10 years)			
	50%	32800 hours (3.74 years)			15800 hours (2.94 years)			
	70%	43800 hours (5.00 years)			43000 hours (4.90 years)			
	100%				43800 hours (5.00 years)			

Extended SRAM cassette	Power-on time ratio ^{*1}	Guaranteed value when used in the R08SFCPU or R16SFCPU			Guaranteed value when used in the R32SFCPU or R120SFCPU			
		Q6BAT	Q7BATN	Q7BAT	Q6BAT	Q7BATN	Q7BAT	
Used (4MB type)	0%	13300 hours (1.51 years)	37143 hours (4.24 years)	33300 hours (3.80 years)	10900 hours (1.24 years)	32051 hours (3.66 years)	27000 hours (3.08 years)	
	30%	19000 hours (2.16 years)	43800 hours (5.00 years)	43800 hours (5.00 years)	15500 hours (1.76 years)	43800 hours (5.00 years)	38500 hours (4.39 years)	
	50%	26600 hours (3.03 years)			21800 hours (2.48 years)			43800 hours (5.00 years)
	70%	43800 hours (5.00 years)			36300 hours (4.14 years)			
	100%	43800 hours (5.00 years)			43800 hours (5.00 years)			
43800 hours (5.00 years)								
Used (8MB type)	0%	9200 hours (1.05 years)	27634 hours (3.15 years)	22900 hours (2.61 years)	8000 hours (0.91 years)	24074 hours (2.75 years)	19800 hours (2.26 years)	
	30%	13100 hours (1.49 years)	39478 hours (4.51 years)	32700 hours (3.73 years)	11400 hours (1.30 years)	34392 hours (3.93 years)	28200 hours (3.21 years)	
	50%	18400 hours (2.10 years)	43800 hours (5.00 years)	43800 hours (5.00 years)	16000 hours (1.82 years)	43800 hours (5.00 years)	39600 hours (4.52 years)	
	70%	30600 hours (3.49 years)			26600 hours (3.03 years)			43800 hours (5.00 years)
	100%	43800 hours (5.00 years)			43800 hours (5.00 years)			
43800 hours (5.00 years)								
Used (ECC-compatible 2MB type)	0%	13300 hours (1.51 years)			43800 hours (5.00 years)			
	30%	19000 hours (2.16 years)	43800 hours (5.00 years)	43800 hours (5.00 years)	15400 hours (1.75 years)	43800 hours (5.00 years)	38500 hours (4.39 years)	
	50%	26600 hours (3.03 years)			21600 hours (2.46 years)			43800 hours (5.00 years)
	70%	43800 hours (5.00 years)			36000 hours (4.10 years)			
	100%	43800 hours (5.00 years)			43800 hours (5.00 years)			
43800 hours (5.00 years)								
Used (ECC-compatible 8MB type)	0%	6100 hours (0.69 years)	17320 hours (1.98 years)	15100 hours (1.72 years)	5500 hours (0.62 years)	15893 hours (1.81 years)	13700 hours (1.56 years)	
	30%	8700 hours (0.99 years)	24743 hours (2.82 years)	21500 hours (2.45 years)	7800 hours (0.89 years)	22704 hours (2.59 years)	19500 hours (2.22 years)	
	50%	12200 hours (1.39 years)	34641 hours (3.95 years)	30200 hours (3.44 years)	11000 hours (1.25 years)	31786 hours (3.63 years)	27400 hours (3.12 years)	
	70%	20300 hours (2.31 years)	43800 hours (5.00 years)	43800 hours (5.00 years)	18300 hours (2.08 years)	43800 hours (5.00 years)	43800 hours (5.00 years)	
	100%	43800 hours (5.00 years)			43800 hours (5.00 years)			
43800 hours (5.00 years)								

*1 The power-on time ratio indicates the ratio of the programmable controller power-on time to 24 hours. (If the total power-on time is 12 hours, the ratio will be 50%. If the total power-on time is 6 hours, the ratio will be 25%.)

FX3U-32BL

■When used in the R00CPU, R01CPU, or R02CPU

The actual service values and guaranteed values are as follows:

- Actual service value (reference value)

Power-on time ratio	Actual service value
0 to 100%	43800 hours (5.00 years)

- Guaranteed value

Power-on time ratio	Guaranteed value
0 to 100%	43800 hours (5.00 years)

■When used in the R102WCPU-W

The actual service values and guaranteed values are as follows:

- Actual service value (reference value)

Power-on time ratio	Actual service value
0%	42400 hours (4.84 years)
30 to 100%	43800 hours (5.00 years)

- Guaranteed value

Power-on time ratio	Guaranteed value
0%	33600 hours (3.83 years)
30 to 100%	43800 hours (5.00 years)

Precautions

Note the following precautions regarding battery life.

- Use a battery within the guaranteed period of life time. If the battery is used exceeding the guaranteed period, back up the data on the device/label memory.
- When SM52 (Battery low) turns on, replace the battery immediately. (📖 Page 207 Battery replacement procedure)

5 INSTALLATION AND WIRING

5.1 Installation Environment

Install a programmable controller according to the installation environment shown in the general specifications. ( Page 136 General Specifications)

Do not install the programmable controller to the following place.

- Ambient temperature is outside the range of 0 to 55°C*1.
- Ambient humidity is outside the range of 5 to 95%RH.
- Condensation occurs because of rapid temperature change.
- Corrosive gas or combustible gas exists.
- Conductive powder such as dust and iron powder, oil mist, salinity, or organic solvent is filled.
- Programmable controller is exposed to direct sunlight.
- Strong electric field or strong magnetic field is generated.
- Programmable controller is subject to vibration and shock.

*1 When an extended temperature range base unit is used, each module can be used in the environment of 0 to 60°C.

5.2 Installation Position

When installing a programmable controller in a control panel, fully consider its operability, maintainability, and environmental resistance.

Control panel

Use a control panel with sufficient strength for the installation environment. For information on protection against electric shock, dust, and water, refer to the following.

■Protection against electric shock

Handle the control panel as follows to protect a person who does not have adequate knowledge of electrical installation from an electric shock.

- Lock the control panel so that only a person who is trained and has acquired enough knowledge of electrical installation can open the panel.
- Design the control panel so that the power supply is automatically shut off when the panel is opened.
- Use a control panel with a protection degree of IP20 or higher.

■Protection from dust and water

The control panel needs to be dustproof and waterproof.

Insufficient dustproof and waterproof lower the dielectric withstand of the control panel, possibly causing dielectric breakdown. For protection against dust and water splashes, install the programmable controllers inside a control panel with a protection degree of IP54 or equivalent.

Installation position for programmable controller

To improve the airflow and change a module easily, provide clearance between the module top/bottom and structures/parts as shown below.

■For a main base unit (slim type main base unit (except for R3□SB)) and an extension base unit

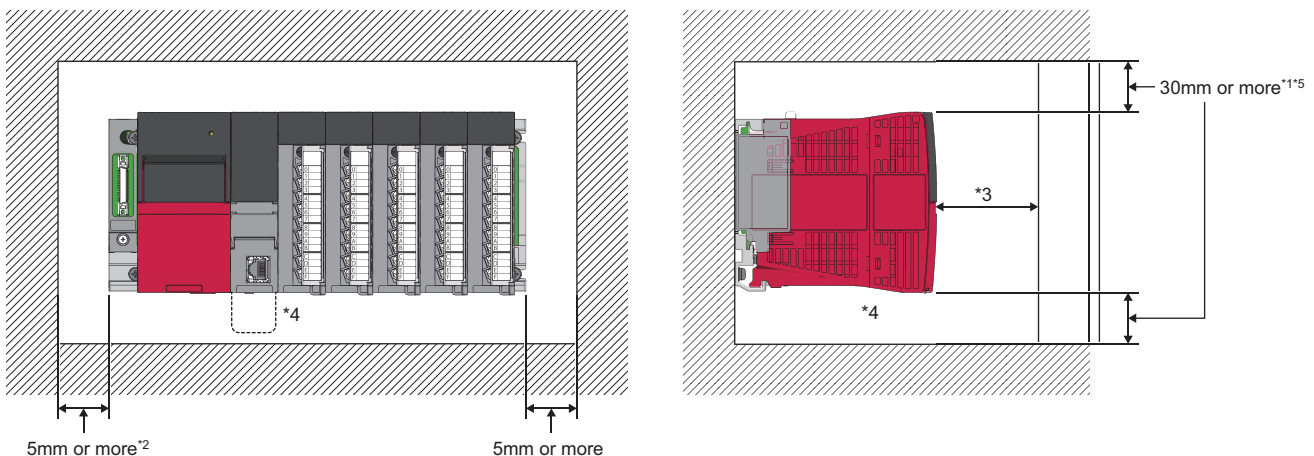

A shaded area shows the ceiling of a control panel, wiring duct, or parts.

- *1 Provide clearance of 30mm or more when the height of a wiring duct is 50mm or less. In other cases, provide clearance of 40mm or more.
- *2 Provide clearance of 20mm or more when an extension cable is connected/removed without removing a power supply module.
- *3 Provide clearance of 20mm or more for a power supply module, 80mm or more for a module using a connector for external devices, and 90mm for a MELSECWinCPU module. Since MELSECWinCPU modules have a depth of 131mm, use a control panel with a depth of 221mm or more.
- *4 Provide clearance of 50mm or more when the Q7BATN is installed, and 45mm or more when the Q7BAT is installed.
- *5 Secure adequate space for wiring when connecting Ethernet cables to an R00CPU, R01CPU, and R02CPU or when connecting an RS-232 connection cable to a MELSECWinCPU module.

■ For a slim type main base unit (R3□SB)

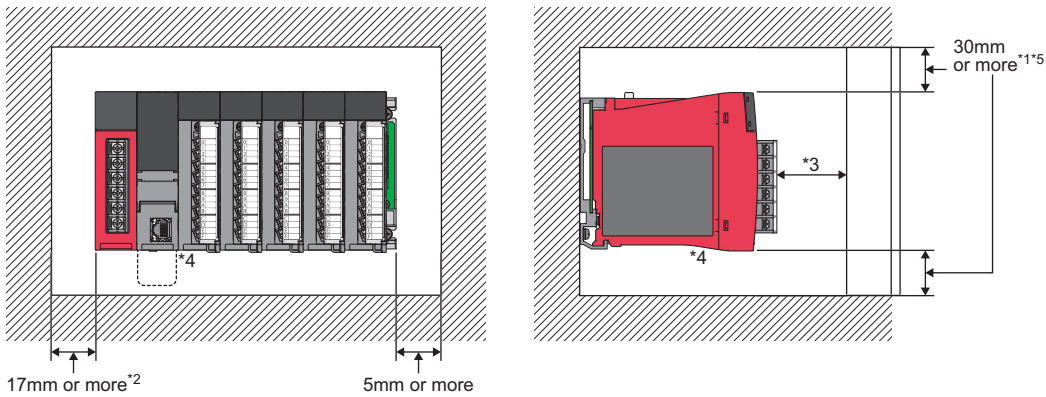

A shaded area shows the ceiling of a control panel, wiring duct, or parts.

- *1 Provide clearance of 30mm or more when the height of a wiring duct is 50mm or less. In other cases, provide clearance of 40mm or more.
- *2 For the slim type main base unit (R3□SB), the wiring of the power supply module protrudes from the left end of the module. Install the unit 17mm or more away to secure the wiring space. Also, if the structures, devices, or parts on the left side of the unit may damage the wire sheath, protect it with an insulator such as a spiral tube.
- *3 Provide clearance of 20mm or more for the slim type power supply module (R61SP) and 80mm or more for a module using a connector for external devices.
- *4 Provide clearance of 50mm or more when the Q7BATN is installed, and 45mm or more when the Q7BAT is installed.
- *5 Secure adequate space for wiring when connecting Ethernet cables to an R00CPU, R01CPU, and R02CPU.

Installation direction for programmable controller

- To improve the airflow for heat dissipation, install a programmable controller in the following direction.

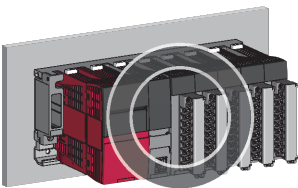

- Do not install the programmable controller in the following direction.

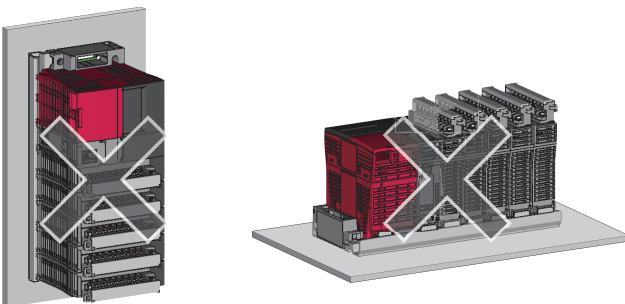

Installation surface

Install a base unit on a flat surface.

If the installation surface is uneven, excessive force is applied to the printed-circuit board, which may cause malfunction.

Installation of programmable controller with other devices

To avoid the close installation of a programmable controller and vibration sources such as an electromagnetic contactor and no fuse breaker, install them in a different control panel or at a distance.

Clearance between a programmable controller and other devices

Provide the following clearance between the programmable controller and other devices such as a contactor and relay to avoid influence from the radiated noise and heat.

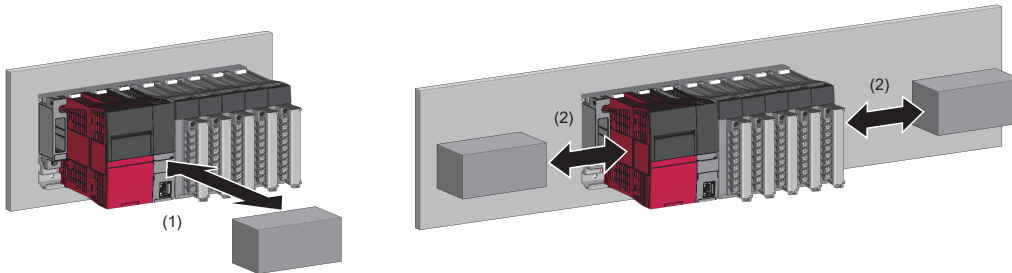

(1) A device in front of a programmable controller: 100mm or more

(2) A device on the right and left of a programmable controller: 50mm or more

5.3 Installing Base Unit to Control Panel

This section describes the installation method for a base unit to a control panel.

Installation method

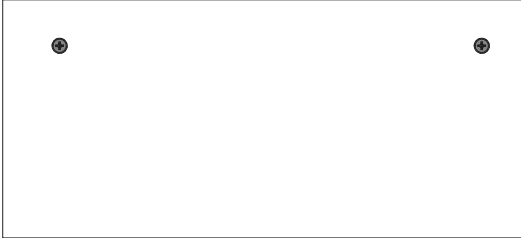

Main base unit, extension base unit

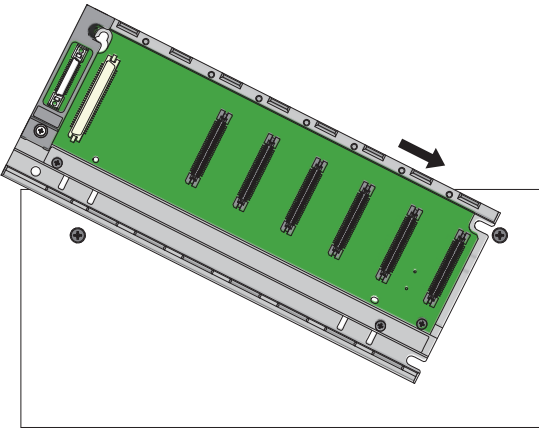

RQ extension base unit

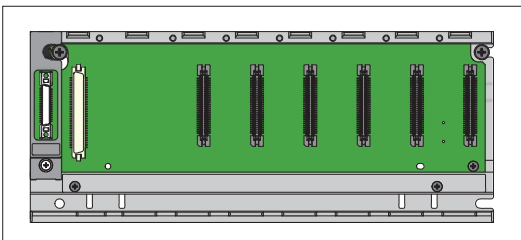
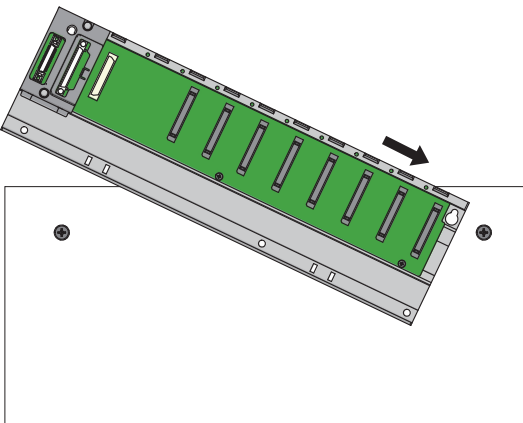

1. Fix two mounting screws for the upper side of the base unit to the control panel.

2. Place the notch on the right side of the base unit to a screw on the right side of the control panel.

When the RQ extension base unit is used, place the bell-shaped hole on the right side of the base unit to the screw on the right side of the control panel.

3. Place the bell-shaped hole on the left side of the base unit to a screw on the left side of the control panel.

4. Fix the mounting screws into the holes at the bottom of the base unit, and retighten all the mounting screws.

Point 

When the base unit mounted modules is installed on the control panel, install the base unit, without a module on the right end slot, on the control panel. The removal method is the same.

Installing the main base unit, without the power supply module on the left end slot, on the control panel is recommended. The mounting screws can be tightened by inserting a screwdriver tilted. The removal method is the same.

5.4 Mounting Base Unit on the DIN Rail

Mounting the base unit on the DIN rail

This section describes the installation method for a base unit to a DIN rail.

A DIN rail adapter (sold separately) is required to install the base unit to the DIN rail.

For the MELSEC-Q series extension base unit, refer to the following.

📖 QCPU User's Manual (Hardware Design, Maintenance and Inspection)

Applicable DIN rail adapter model

■ Main base unit, extension base unit

- For R3□B, R3□SB, R3□B-HT, R6□B, R6□B-HT, R3□RB, R3□RB-HT, R6□RB, R6□RB-HT, R6□WRB, R6□WRB-HT: R6DIN1

Model	Pieces				
	Hook A	Hook B-C (with two mounting screws)	Stopper	Square washer	Mounting screw (M5×10)
R6DIN1	2	2	2	3	3

When the base unit is used as a UL/cUL listed product, the DIN rail adapter cannot be used.

■ RQ extension base unit

Use the MELSEC-Q series DIN rail adapter for the RQ extension base unit.

- For RQ68B, RQ612B: Q6DIN1
- For RQ65B: Q6DIN2

Model	Pieces				
	Adapter (larger)	Adapter (smaller)	Stopper	Square washer	Mounting screw (M5×10)
Q6DIN1	2	4	2	3	3
Q6DIN2	2	3	2	2	2

Applicable DIN rail model (IEC 60715)

- TH35-7.5Fe
- TH35-7.5Al
- TH35-15Fe

Interval between DIN rail mounting screws

When a DIN rail is used, tighten DIN rail mounting screws in interval of 200mm or less to ensure the sufficient strength of the rail.

Tighten the DIN rail by using the mounting screws and square washers included with the DIN rail adapter. When the TH35-15Fe is used, the square washers are not required.

- When the base unit which has eight slots or more is used, screw three spots as below.

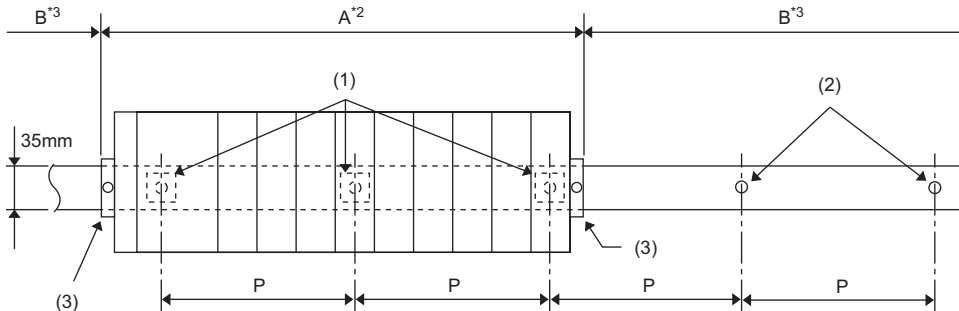

P = 200mm or less

- (1) Mounting screws (included with the DIN rail adapter)*1
- (2) Mounting screws (sold separately)
- (3) Stoppers

- When the base unit which has five slots or less is used, screw two spots as below.

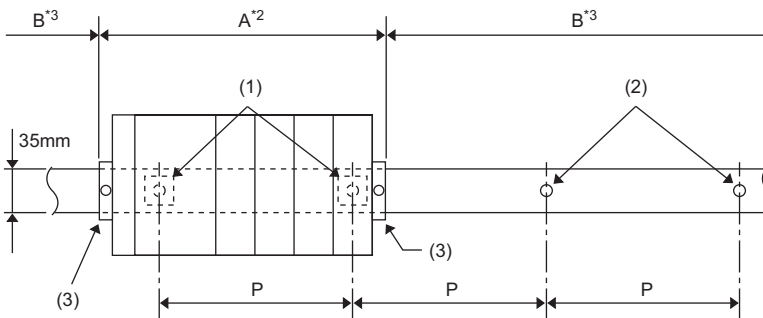

P = 200mm or less

- (1) Mounting screws (included with the DIN rail adapter)*1
- (2) Mounting screws (sold separately)
- (3) Stoppers

*1 The following shows the installation position of the square washer.

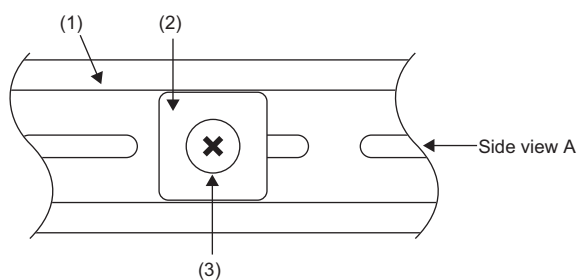

- (1) DIN rail
- (2) Square washer
- (3) Mounting screw (M5×10)
- (4) Mounting side such as a control panel

• A arrow view

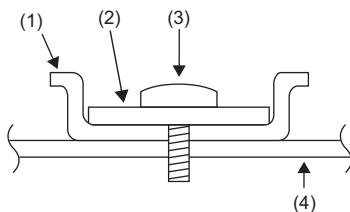

*2 For the A position, tighten the DIN rail on the control panel by using the mounting screws and square washers included with the DIN rail adapter.

*3 For the B position where the base unit is not mounted, the mounting screws and square washers included with the DIN rail adapter are not required. Tighten the DIN rail with the mounting screws (sold separately).

■Precautions

- Use the DIN rail which M5 size screws can be used.
- Use only one square washer for each mounting screw. Use only the square washers included with the DIN rail adapter. If two or more square washers are used together for one mounting screw, the screw may interfere with the base unit.
- Align the square washer parallel to the DIN rail.

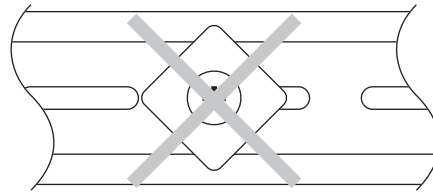
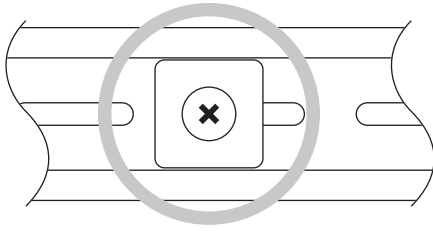

Installing the DIN rail adapter

When the base unit is mounted on the DIN rail, install the DIN rail adapter on the base unit.

■ Main base unit, extension base unit

Use the hook As, hook B-Cs, and stoppers included with the MELSEC iQ-R series DIN rail adapter for the main base unit and extension base unit.

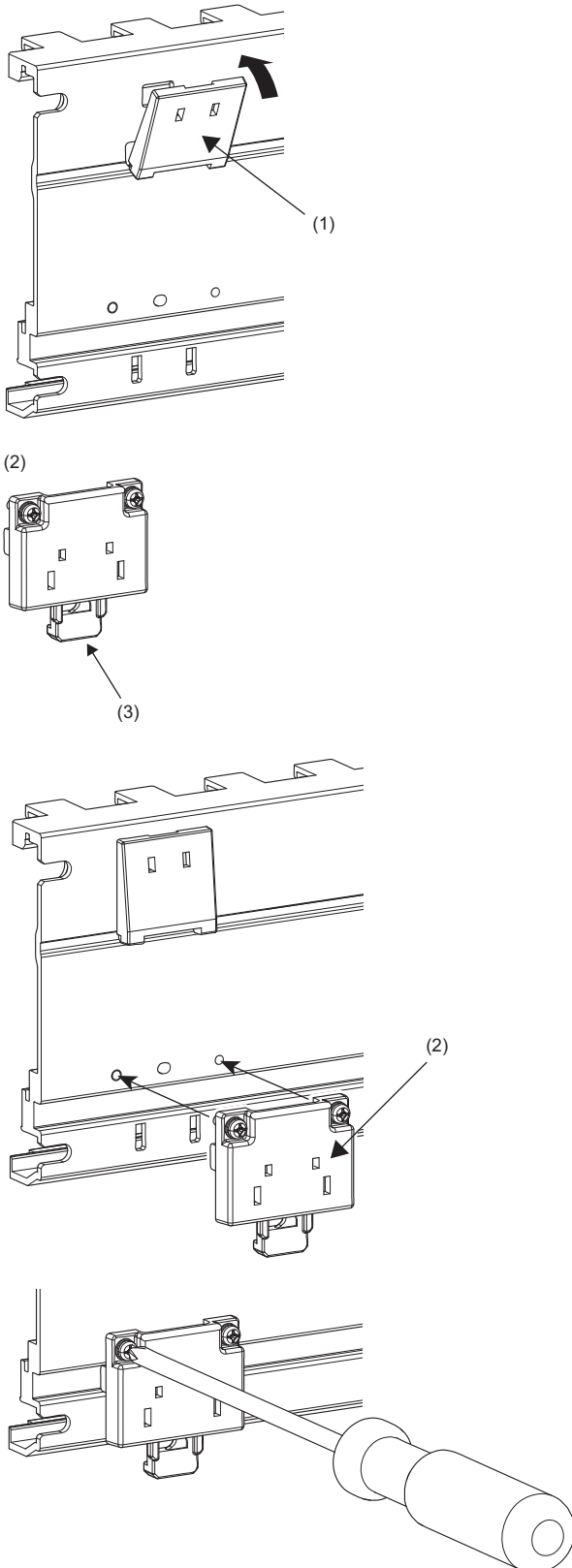

1. Insert the hook A (1) to the lower square hole of two square holes at the upper part of the base unit and push the upper part of the hook until it clicks. (two spots)

2. Project the hook B (3) of the hook B-C (2) on the downside shown the left figure.

3. Push the tab of the hook B-C into two square holes at the lower part of the base unit until it clicks. (two spots)

4. Tighten the mounting screws (M3×10) of the hook B-C with a screwdriver and fix the hook B-C. (total four spots (two mounting screws per one hook B-C), tightening torque: 0.37 to 0.48N·m)

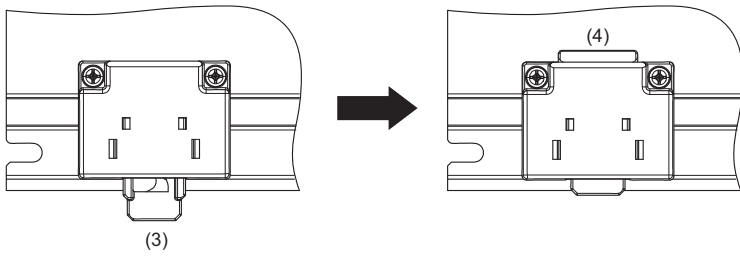

5. Project the tab (4) of the hook B-C on the upside by pushing up the hook B (3).

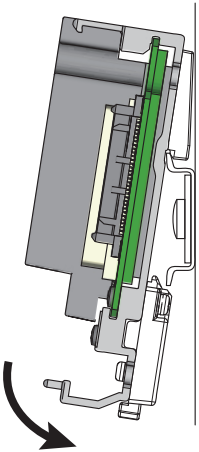

6. Hitch the upper part of the base unit to the DIN rail and push the lower part of the base unit until it clicks.
7. Fix the stopper of the DIN rail. (☞ Page 168 Fixing of the stopper)

■RQ extension base unit

Use the adapters (larger), adapters (smaller), and stoppers included with the MELSEC-Q series DIN rail adapter for the RQ extension base unit.

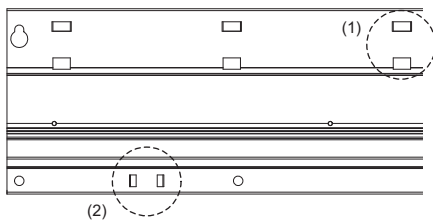

- (1) Spot for the hook of the adapter (smaller)
- (2) Spot for the hook of the adapter (larger)

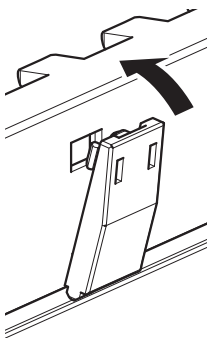
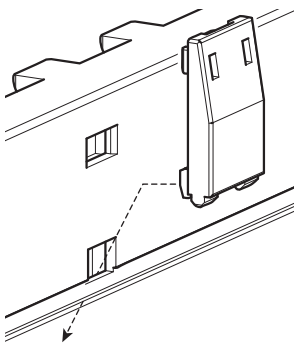

1. Insert the hook of the adapter (smaller) into the lower square hole of two square holes at the upper part of the base unit and push the upper part of the adapter until it clicks.

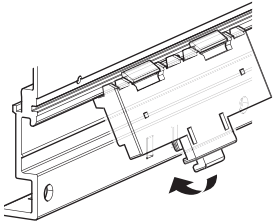
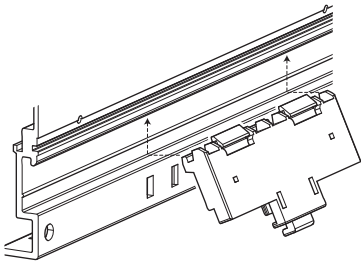

- 2.** Insert the adapter (larger) into the groove of the base unit from below. As the adapter is inserted into the groove, push the lower part of the adapter (larger) into two square holes at the lower part of the base unit until it clicks.
- 3.** Mount the base unit installed the DIN rail adapter on the DIN rail.
- 4.** Fix the stopper of the DIN rail. ( Page 168 Fixing of the stopper)

Fixing of the stopper

Fix the stopper to the DIN rail after the base unit installed the DIN rail adapter is mounted on the DIN rail.

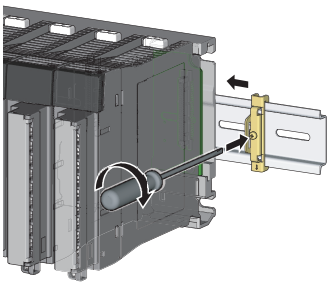
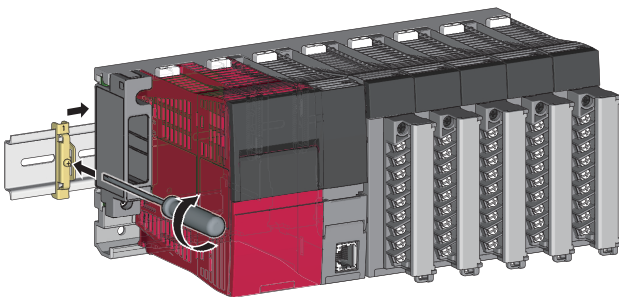
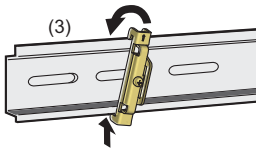
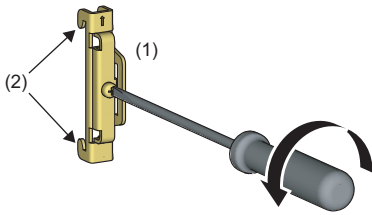

1. Loosen the screw at the upper part of the stopper (1).
2. For the stopper fixed to the left side of the base unit, turn up the arrow mark printed on the stopper and hitch the tab (2) at the lower part of the stopper to the DIN rail (3).
3. Hitch the tab at the upper part of the stopper to the upper part of the DIN rail.
4. Fix the stopper on the right side of the base unit upside down for the stopper of the left side.
5. Slide the stopper to the end of the base unit.
6. Tighten the screw of the stopper with a screwdriver. (tightening torque: 1.00 to 1.35N·m)
7. Check that both stoppers are fixed on the DIN rail securely.

Point

When the base unit is mounted on the DIN rail, select the DIN rail in the light of the following dimensions of the stopper.

For the dimensions (W) of the base unit, refer to the following.

☞ Page 141 Performance Specifications of Base Unit

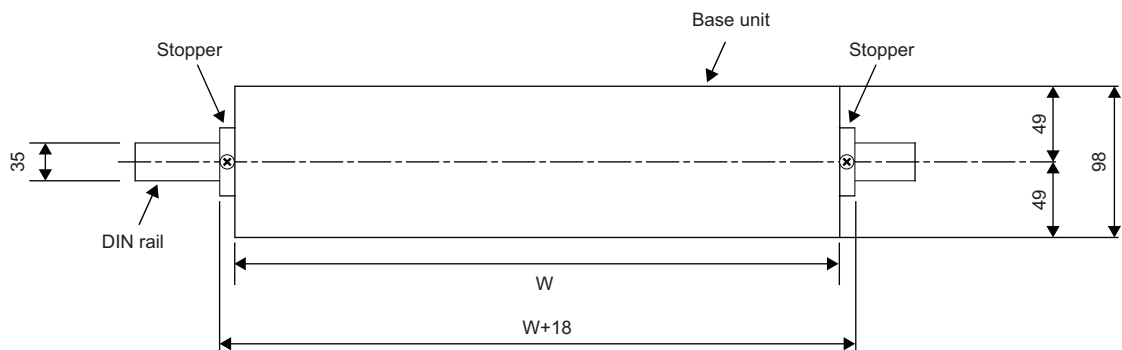

Unit: mm

The method for fixing the DIN rail stopper is an example. Fix the module in accordance with the manual for the DIN rail stopper used.

Lateral dimensions of the base unit with the DIN rail

This section describes the lateral dimensions when the base unit is mounted on the DIN rail.

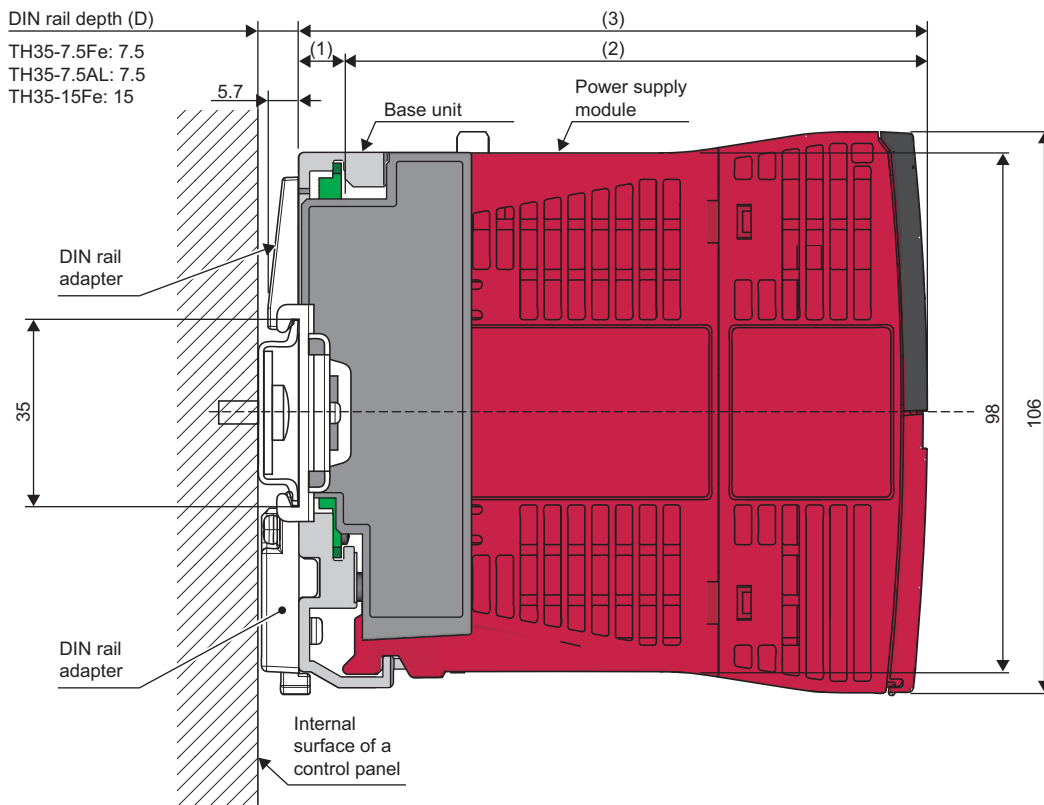

The following table lists the dimensions (1), (2), and (3) in the figure when (2) is the power supply module. (1) differs depending on a base unit. (2) and (3) differ depending on the module used.

No.	MELSEC iQ-R series main base unit and extension base unit	RQ extension base unit and MELSEC-Q series extension base unit
(1)	8.9mm	7.5mm
(2)	110.0mm	115.0mm
(3)	118.9mm	122.5mm

5.5 Connection Method for the Extension Base Unit

Up to seven base units can be extended including the extension base unit, RQ extension base unit, and MELSEC-Q series extension base unit.

Use an extension cable for the connection with the extension base unit.

Connect the extension cable to the connector of the base unit in order of OUT→IN. Do not connect the extension cable to the connector in order of IN→IN, OUT→OUT, or IN→OUT.

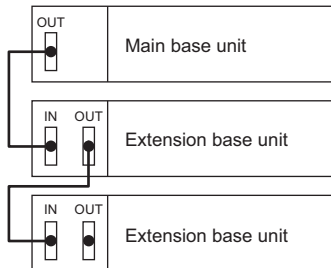

The extension level setting for the extension base unit and RQ extension base unit is not required, because the extension level is set automatically in order near from the main base unit. The setting cannot be changed arbitrarily.

When a redundant system with redundant extension base unit is configured

Connect OUT of the main base unit of system A to either IN1 or IN2 of the redundant extension base unit using an extension cable. Do the same in system B. (For OUT of the main base unit of both system A and system B, there is no difference between using IN1 and using IN2 of the redundant extension base unit.)

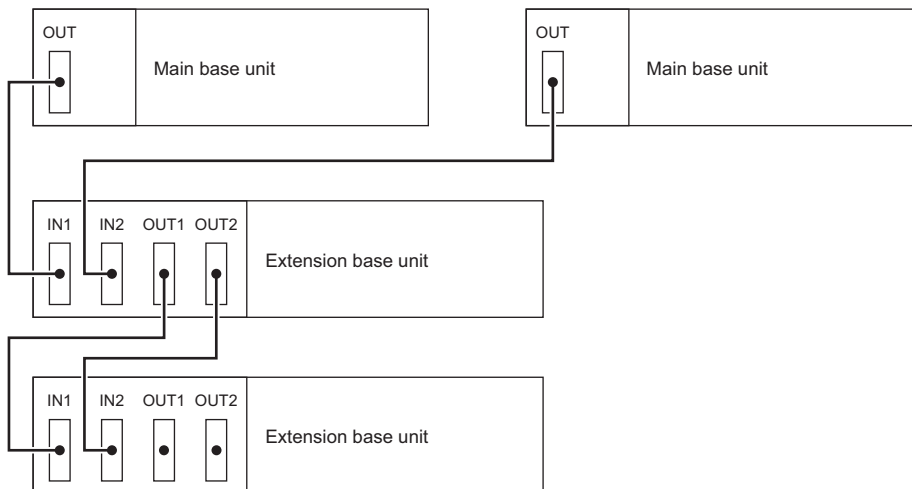

Connecting extension base units

- To make an extension cable between the two redundant extension base units redundant, connect OUT1 of one redundant extension base unit to IN1 of the redundant extension base unit in the level immediately below using an extension cable. Do the same to OUT2 of one redundant extension base unit and IN2 of the redundant extension base unit in the level immediately below.*1

*1 Extension cables in the extension level 1 and below levels are not necessarily redundant. (Connect OUT1 to IN1 only or OUT2 to IN2 only, using a single extension cable.) In this case, however, a continuation error will be detected in the control system at startup of the redundant system. To avoid this error, set "Extension cable redundant error detection setting at startup" in "Redundant System Settings" of "CPU Parameter". (MELSEC iQ-R CPU Module User's Manual (Application))

- When using an extension base unit other than the redundant extension base unit in the extension level 2 and later, connect either OUT1 or OUT2 of the redundant extension base unit in the extension level 1 to IN of the extension base unit in the extension level 2. In this case, there is no difference between using OUT1 or OUT2.

When MELSEC-Q series modules are used

This section describes the connection between the RQ extension base unit and MELSEC-Q series extension base unit. The RQ extension base unit is connected to the lower level of the main base unit or MELSEC iQ-R series extension base unit with a MELSEC iQ-R series extension cable.

- When the RQ extension base unit is connected to the lower level of the main base unit
- When the RQ extension base unit is connected to the lower level of the extension base unit

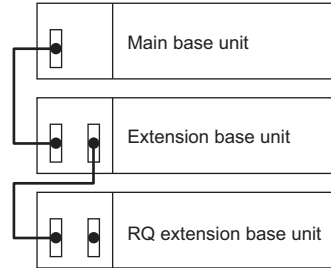
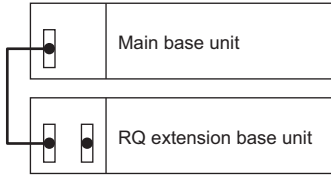

When additional MELSEC-Q series modules are mounted, the MELSEC-Q series extension base unit is connected to the lower level of the RQ extension base unit with a MELSEC-Q series extension cable.

- When the RQ extension base unit is connected to the lower level of the main base unit
- When the RQ extension base unit is connected to the lower level of the extension base unit

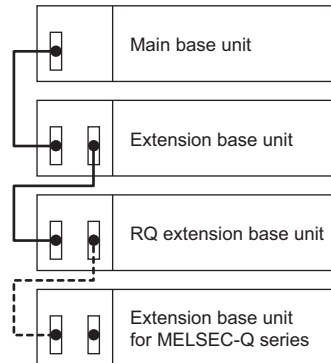
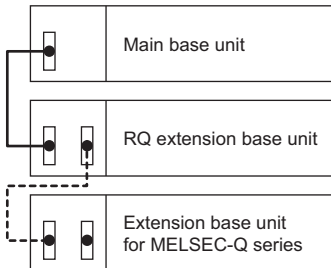

The dot lines show the MELSEC-Q series extension cables.

Point

For the MELSEC-Q series extension base unit that can be used in the MELSEC iQ-R series system, refer to the following.

☞ Page 83 MELSEC-Q series

The MELSEC-Q series extension base unit is required the extension level setting with the connector pin for the extension level setting. (☞ Page 172 Setting method with connector pin for extension level setting)

	Extension level	Setting necessity
	—	—
	1	×
	2	×
	3	○
	4	○

Setting method with connector pin for extension level setting

This section describes the extension level setting method for the MELSEC-Q series extension base unit.

Set the extension level surely, because the level is set 1 by the factory default.

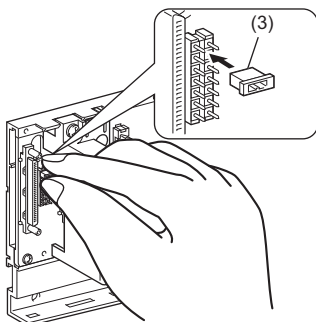
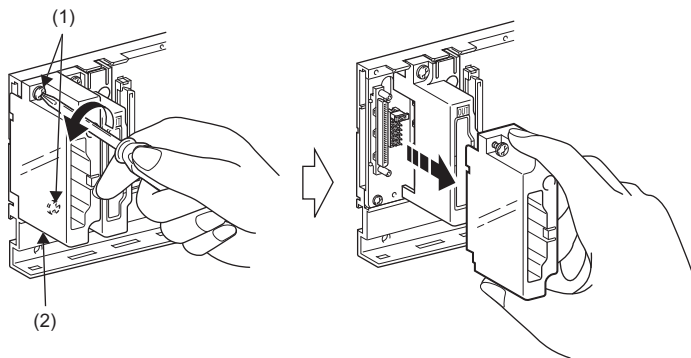

Extension level	2	3	4	5	6	7																																																																																				
Insert position of a connector pin for extension level setting	<table border="1"> <tr><td>○</td><td>○</td></tr> <tr><td>●</td><td>○</td></tr> <tr><td>○</td><td>○</td></tr> <tr><td>○</td><td>○</td></tr> <tr><td>○</td><td>○</td></tr> <tr><td>○</td><td>○</td></tr> <tr><td>○</td><td>○</td></tr> </table>	○	○	●	○	○	○	○	○	○	○	○	○	○	○	<table border="1"> <tr><td>○</td><td>○</td></tr> <tr><td>○</td><td>○</td></tr> <tr><td>○</td><td>○</td></tr> <tr><td>○</td><td>○</td></tr> <tr><td>○</td><td>○</td></tr> <tr><td>○</td><td>○</td></tr> <tr><td>○</td><td>○</td></tr> </table>	○	○	○	○	○	○	○	○	○	○	○	○	○	○	<table border="1"> <tr><td>○</td><td>○</td></tr> <tr><td>○</td><td>○</td></tr> <tr><td>○</td><td>○</td></tr> <tr><td>○</td><td>○</td></tr> <tr><td>○</td><td>○</td></tr> <tr><td>○</td><td>○</td></tr> <tr><td>○</td><td>○</td></tr> </table>	○	○	○	○	○	○	○	○	○	○	○	○	○	○	<table border="1"> <tr><td>○</td><td>○</td></tr> <tr><td>○</td><td>○</td></tr> <tr><td>○</td><td>○</td></tr> <tr><td>○</td><td>○</td></tr> <tr><td>○</td><td>○</td></tr> <tr><td>○</td><td>○</td></tr> <tr><td>○</td><td>○</td></tr> </table>	○	○	○	○	○	○	○	○	○	○	○	○	○	○	<table border="1"> <tr><td>○</td><td>○</td></tr> <tr><td>○</td><td>○</td></tr> <tr><td>○</td><td>○</td></tr> <tr><td>○</td><td>○</td></tr> <tr><td>○</td><td>○</td></tr> <tr><td>○</td><td>○</td></tr> <tr><td>○</td><td>○</td></tr> </table>	○	○	○	○	○	○	○	○	○	○	○	○	○	○	<table border="1"> <tr><td>○</td><td>○</td></tr> <tr><td>○</td><td>○</td></tr> <tr><td>○</td><td>○</td></tr> <tr><td>○</td><td>○</td></tr> <tr><td>○</td><td>○</td></tr> <tr><td>○</td><td>○</td></tr> <tr><td>○</td><td>○</td></tr> </table>	○	○	○	○	○	○	○	○	○	○	○	○	○	○
○	○																																																																																									
●	○																																																																																									
○	○																																																																																									
○	○																																																																																									
○	○																																																																																									
○	○																																																																																									
○	○																																																																																									
○	○																																																																																									
○	○																																																																																									
○	○																																																																																									
○	○																																																																																									
○	○																																																																																									
○	○																																																																																									
○	○																																																																																									
○	○																																																																																									
○	○																																																																																									
○	○																																																																																									
○	○																																																																																									
○	○																																																																																									
○	○																																																																																									
○	○																																																																																									
○	○																																																																																									
○	○																																																																																									
○	○																																																																																									
○	○																																																																																									
○	○																																																																																									
○	○																																																																																									
○	○																																																																																									
○	○																																																																																									
○	○																																																																																									
○	○																																																																																									
○	○																																																																																									
○	○																																																																																									
○	○																																																																																									
○	○																																																																																									
○	○																																																																																									
○	○																																																																																									
○	○																																																																																									
○	○																																																																																									
○	○																																																																																									
○	○																																																																																									
○	○																																																																																									

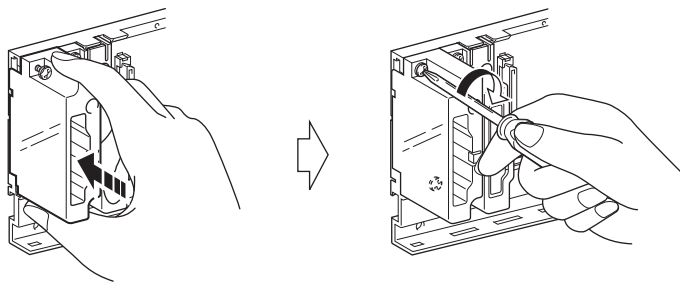

1. The extension level setting connector of the MELSEC-Q series extension base unit is located within the IN side extension connector cover. Loosen the fixing screws (1) of the IN side extension connector cover and remove the extension connector cover (2).
2. Insert the connector pin for the extension level setting (3) into the connector (PIN1) between the IN and OUT sides extension cable connector.
3. Set the extension level using the connector pin for the extension level setting in accordance with the left figure.
4. Install the IN side extension connector cover on the MELSEC-Q series extension base unit and tighten the screws of the extension connector cover. (tightening torque: 0.36 to 0.48N·m)

Point

Set the extension level in order of connection, starting from the extension base unit connected to the main base unit.

Set the correct extension level for the extension level setting connector. The incorrect settings as below may cause the incorrect input or incorrect output. When any extension level is skipped, slots cannot be reserved because no slots will be allocated to a skipped extension base unit.

- Any extension level is skipped.
- The same extension level is set to two or more extension base units.
- Two or more connector pins for the extension level setting are inserted, or no connector pins are not inserted.

For details on the extension level setting, refer to the following.

📖 QCPU User's Manual (Hardware Design, Maintenance and Inspection)

Voltage drop when a MELSEC-Q series extension base unit is used

When the Q5□B is used, the Q5□B is supplied with 5VDC from the power supply module on the RQ extension base unit, a voltage drop occurs at extension cables. Incorrect input or output may occur if the specified voltage (4.75VDC or higher) is not supplied to the IN connector of the Q5□B.

When the Q5□B is used, check that the IN connector of the Q5□B set as the last level is supplied with 4.75VDC or higher. Connecting the extension base unit to the lower level of the RQ extension base unit with the shortest extension cable is recommended to reduce the influence of the voltage drop.

The following table lists the conductor resistance value for each extension cable.

Model	Conductor resistance value for extension cable
QC05B	0.044Ω
QC06B	0.051Ω
QC12B	0.082Ω
QC30B	0.172Ω
QC50B	0.273Ω
QC100B	0.530Ω

The voltage drop can be checked on the engineering tool.

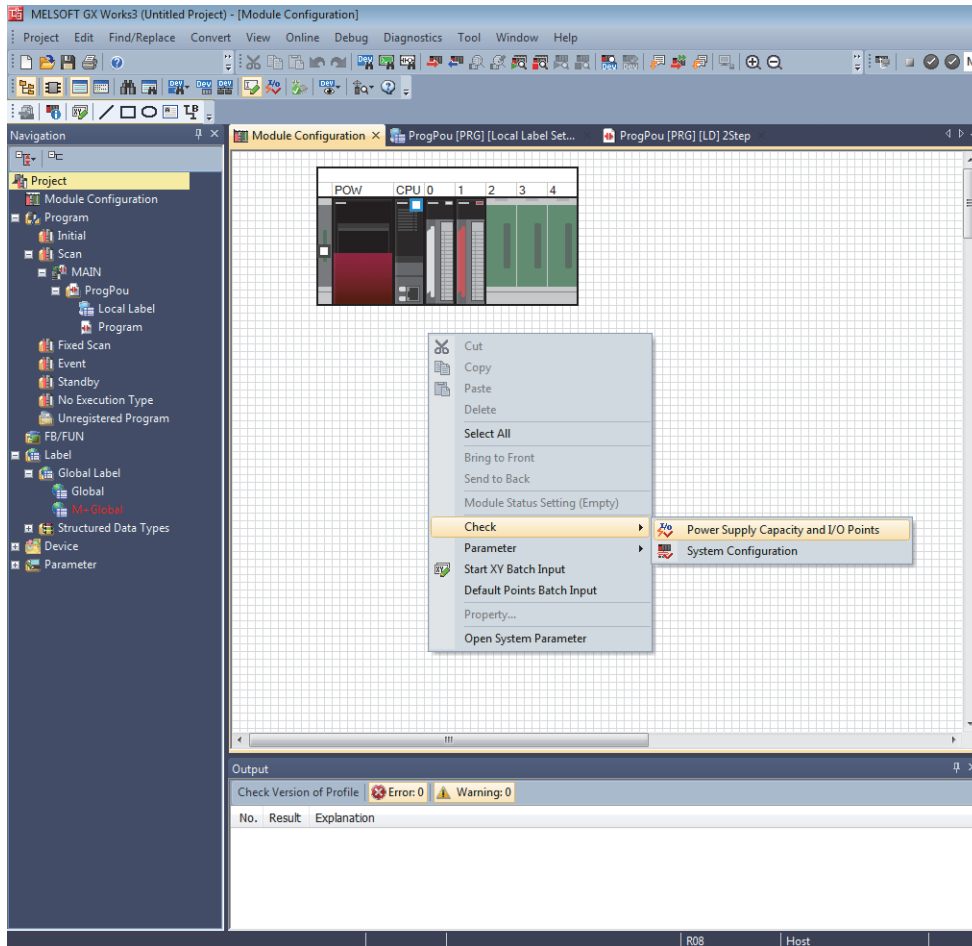

The following window shows the check result.

Base/Cable	Slot	Model Name	Consumption Current	Total Consumption Current	Total Drop Voltage	Total I/O Points
R35B	-	R35B	0.58A	1.81A / 6.5A		80 Point / 4096 Point
	[Power Supply]	R61P	-			
	[CPU]	R04CPU	0.67A			
	[0]	RX10	0.11A			
	[1]	RY10R2	0.45A			

■When only the Q5□B is connected to the lower level of the RQ extension base unit

The 5VDC output voltage of the power supply module on the RQ extension base unit is set to 4.90VDC (minimum value). Therefore, the Q5□B can be used when the voltage drop at the extension cable is 0.15V or lower ($4.9V - 4.75V = 0.15V$).

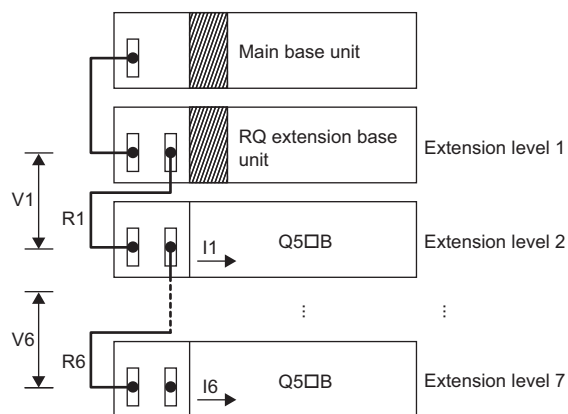

Diagonal lines show the power supply modules.

Symbol	Description
V1	Voltage drop at the extension cable between the RQ extension base unit and the Q5□B
Vn	Voltage drop at the extension cable between the Q5□B set as the extension level n and the extension level n+1
R1	Resistance value for the cable between the RQ extension base unit and the Q5□B
Rn	Resistance value for the extension cable between the Q5□B set as the extension level n and the extension level n+1
I1 to I6	Current consumption value (5VDC) at the extension level 2 to 7*1

*1 Sum total (I1 to I6) of the current consumption by the Q5□B and current consumption by I/O modules and intelligent function modules mounted on the Q5□B differs depending on modules mounted on the Q5□B. For detail, refer to the following.

User's manual for the module used

Mounting position of the Q5□B	Voltage drop for the extension cable at each extension level						Sum total (V) of voltage drops to IN connector of the Q5□B
	V1	V2	V3	V4	V5	V6	
Extension level 2	R1·I1	—	—	—	—	—	V=V1
Extension level 3	R1(I1+I2)	R2·I2	—	—	—	—	V=V1+V2
Extension level 4	R1(I1+I2+I3)	R2(I2+I3)	R3·I3	—	—	—	V=V1+V2+V3
Extension level 5	R1(I1+I2+I3+I4)	R2(I2+I3+I4)	R3(I3+I4)	R4·I4	—	—	V=V1+V2+V3+V4
Extension level 6	R1(I1+I2+I3+I4+I5)	R2(I2+I3+I4+I5)	R3(I3+I4+I5)	R4(I4+I5)	R5·I5	—	V=V1+V2+V3+V4+V5
Extension level 7	R1(I1+I2+I3+I4+I5+I6)	R2(I2+I3+I4+I5+I6)	R3(I3+I4+I5+I6)	R4(I4+I5+I6)	R5(I5+I6)	R6·I6	V=V1+V2+V3+V4+V5+V6

■When the Q6□B is connected between the RQ extension base unit and the Q5□B

The 5VDC output voltage of the power supply module on the Q6□B is set to 4.90VDC (minimum value).

Therefore, the Q5□B can be used when the voltage drop at the extension cable is 0.15V or lower ($4.9V - 4.75V = 0.15V$).

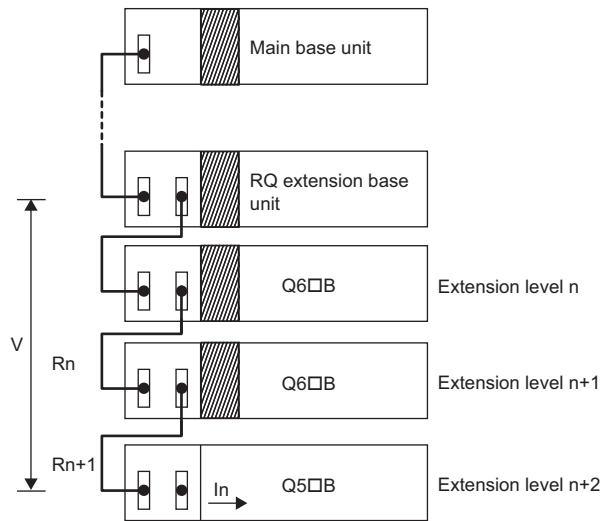

Diagonal lines show the power supply modules.

Symbol	Description
V	Voltage drop at the extension cable between the RQ extension base unit and the Q5□B
In	Current consumption (5VDC) when the Q5□B is used as the extension level n+2 (n = 1 to 5), n: Extension level for the Q6□B (Sum total of the current consumption by the Q5□B and current consumption by I/O modules and intelligent function modules mounted on the Q5□B)
Rn	Resistance value for the extension cable between the RQ extension base unit and the Q6□B or the Q6□B and the Q6□B
Rn+1	Resistance value for the extension cable between the Q6□B and the Q5□B

Mounting position		Sum total (V) of the voltage drop at the extension cable from the main base unit to the IN connector of the Q5□B
Q6□B	Q5□B	
Extension level 2	Extension level 3	$V=(R1+R2)I1$
Extension level 2 to 3	Extension level 4	$V=(R1+R2+R3)I2$
Extension level 3 to 4	Extension level 5	$V=(R1+R2+R3+R4)I3$
Extension level 4 to 5	Extension level 6	$V=(R1+R2+R3+R4+R5)I4$
Extension level 5 to 6	Extension level 7	$V=(R1+R2+R3+R4+R5+R6)I5$

5.6 Connection/Disconnection of Extension Cable

This section describes the connection/disconnection procedure of an extension cable.

MELSEC iQ-R series extension cable

Connection procedure

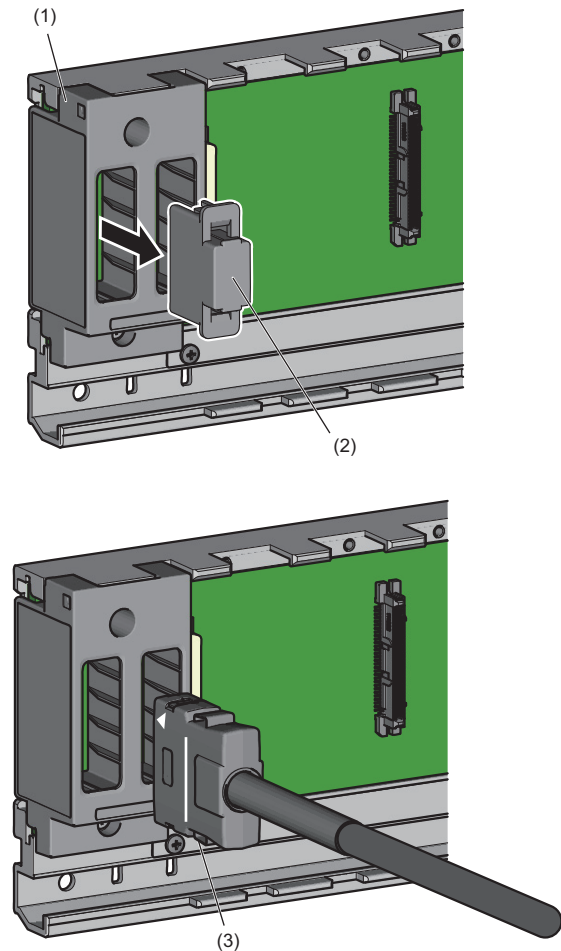

1. When an extension connector protective cover (2) is attached to the extension connector cover (1), remove it before the extension cable is connected to the base unit.

2. Insert the connector (3) of the extension cable with the triangle mark at the left side to the connector of the base unit. Lock the connector securely until it clicks.

Removal procedure

To disconnect the extension cable, hold the connector part with pushing two lock buttons on the connector.

MELSEC-Q series extension cable

Connection procedure

RQ extension base unit

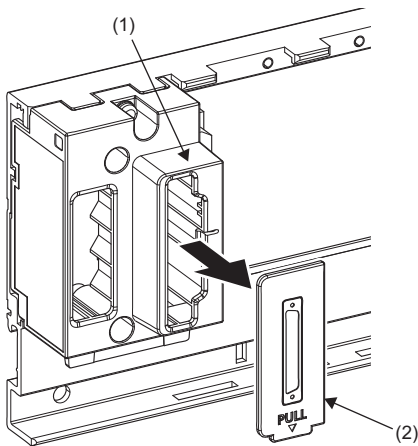

MELSEC-Q series extension base unit

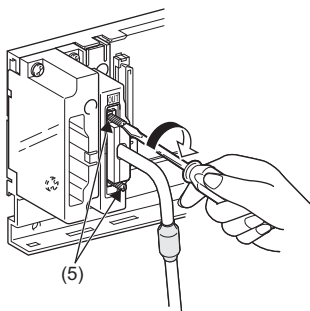
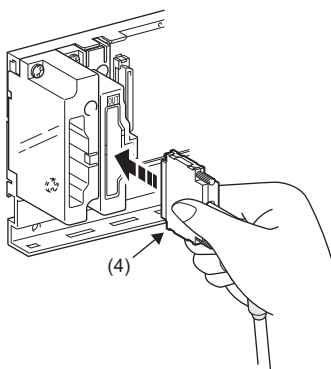
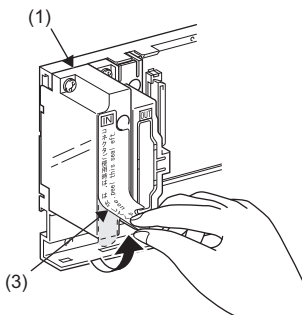

1. Remove the extension connector protective cover (2) from the extension connector cover (1) of the RQ extension base unit before the extension cable is connected to the base unit. For the MELSEC-Q series extension base unit, peel the seal (3) on the extension connector cover (1).

2. Connect the extension cable connector to the connector of the base unit holding the connector part (4) of the extension cable correctly.

3. After connection, tightening the connector fixing screws (5) on the extension cable connector securely. (tightening torque: 0.20N·m)

Removal procedure

Remove the connector part of the extension cable after loosening the fixing screws and checking that the screws are coming off completely.

Handling precautions

- Connect an extension cable to the base unit with the extension connector cover.
- When an extension cable is connected, keep 55mm or more as the minimum bending radius for the cable. Failure to do so may result in malfunction because of the characteristic deterioration or disconnection.
- Keep the overall cable distance within 20m in total length of extension cables. When MELSEC-Q series extension cables are used, keep the overall cable distance within 13.2m in total length of a MELSEC iQ-R series extension cables and the MELSEC-Q series extension cables.
- Do not install extension cables together with the main circuit lines (high voltage and large current).
- For an extension cable, hold the connector part of the cable. Holding a ferrite core installed at both ends of the extension cable may cause the cable disconnection inside the connector.
- Do not displace the ferrite core when the extension cable is used. Doing so may change the characteristics.
- Do not connect a ten-meter extension cable (RC100B) to a base unit that the 10m mark is not printed on its extension connector cover. Connecting them may cause an error.
- If connectors of the MELSEC iQ-R series extension cable are hard to fit in, connect the cable with the lock buttons on the connector pushed.

5.7 Wiring

This section describes the wiring common to all modules.

- For the wiring of each module, refer to the following.
 - 📖 User's manual (Startup) for the module used
 - For the wiring for a redundant system, refer to the following.
 - 📖 MELSEC iQ-R CPU Module User's Manual (Application)

Wiring to the power supply module

This section describes the wiring to the power supply module.

The terminal block of the power supply module has a screw size of M4. Wire cables to the terminal block with the applicable solderless terminal RAV1.25-4 or RAV2-4. Tighten the terminal screws of the power supply module in the range of 1.02 to 1.38 N·m.

Note, however, that the +24V and 24G terminals of the R61SP and R62P have a screw size of M3.5. Wire cables to the terminal block with the applicable solderless terminal RAV1.25-3.5 or RAV2-3.5. Tighten the terminal screws of the power supply module in the range of 0.66 to 0.89 N·m.

Wire

Use the wires in the following table for the power supply module.

Applicable wire size	Type	Material	Temperature rating
0.75 to 2mm ² (18 to 14 AWG)	Stranded wire	Copper	75°C or higher

Wiring example

The following figures show wiring examples of the power cables connected to a main base unit and extension base unit and the ground cables.

For wiring examples for each power supply module, refer to the manual included with the power supply module. (📖 Before Using the Product)

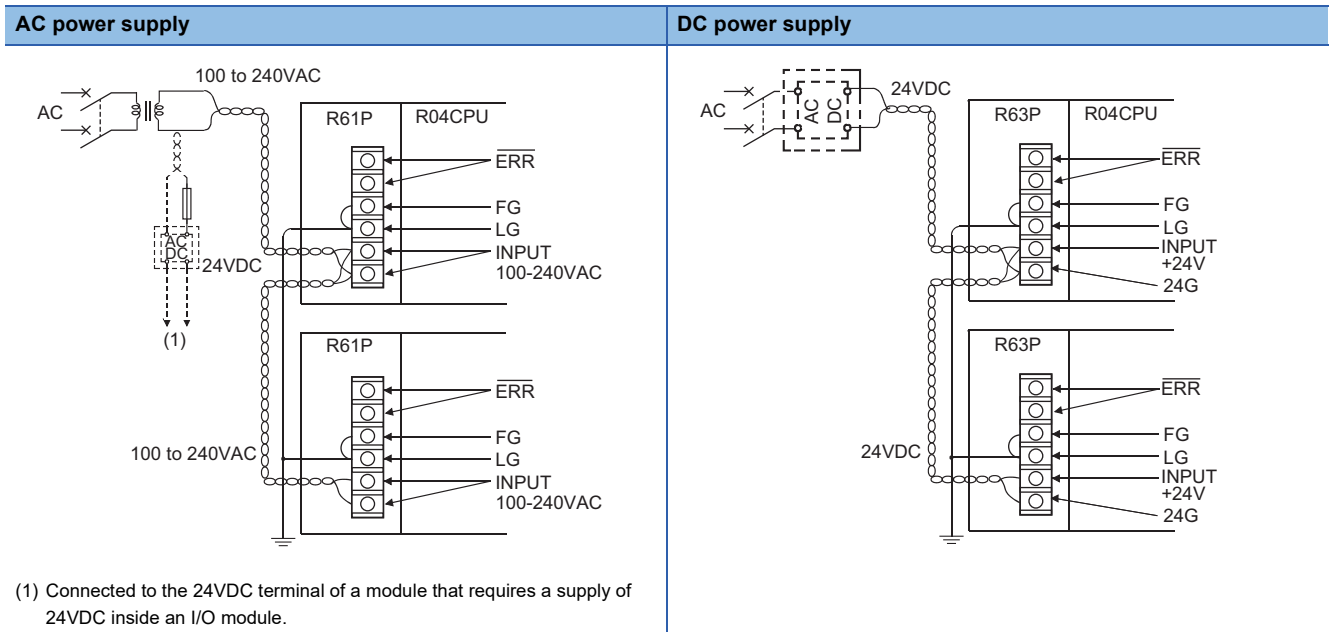

The following figure shows a wiring example of a redundant power supply system.

Use a power supply in a different system for each redundant power supply module (A or B, as shown below) so that the redundant power supply modules are powered on or off individually at replacement.

- AC power supply

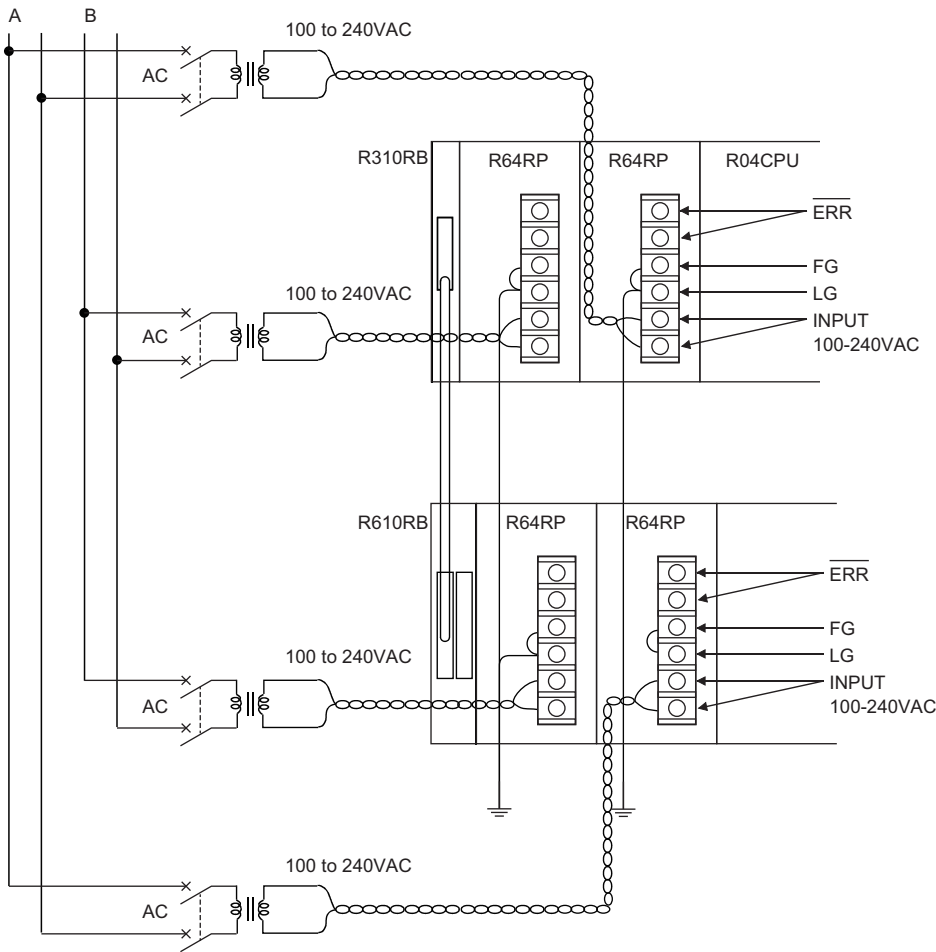

Point

- Power cables must be twisted starting from the connected terminal, and connected between modules at the shortest distance possible. Also, use the thickest wire (maximum 2mm²) to reduce the voltage drop.
- For the wiring to a terminal block, use a solderless terminal.
- Use UL listed solderless terminals, and for processing, use a tool recommended by their manufacturer.
- To prevent the short-circuit because of loosening screws, use the solderless terminal with an insulation sleeve of 0.8mm or less. Note that up to two solderless terminals can be connected per terminal block.

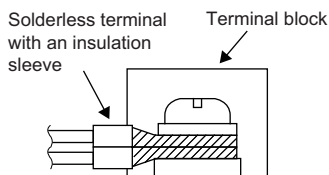

- Ground the LG and FG terminals after short-circuiting them. Failure to do so may be susceptible to the noise. The LG terminal has a half potential of the input voltage.
- When two redundant power supply modules operate in parallel as a redundant power supply system, it is recommended to connect the one redundant power supply module to an uninterruptible power supply (UPS).

Precautions

- Wire cables of the programmable controller power supply, I/O power supply, and motor power supply separately as shown below.

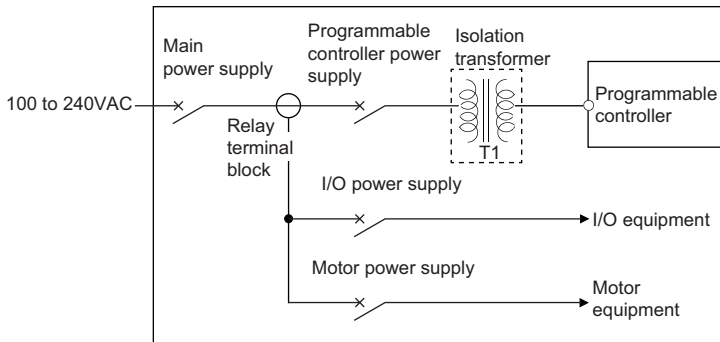

- Use an isolation transformer to reduce the noise such as the lightning surge. (☞ Page 266 Isolation transformer)
- Make sure to connect a breaker or an external fuse between the power supply and the power input terminals (L and N) of this product so that the power can be shut off at the power input side of this product. Without a breaker or an external fuse, a large current keeps flowing if the product fails, causing a smoke and fire. (When the programmable controller is used alone, connecting a breaker around 10A or an external fuse is recommended.)
- Avoid connecting the 24VDC output of two or more power supply modules in parallel to supply power to one I/O module. This parallel connection causes a breakdown of the power supply modules.

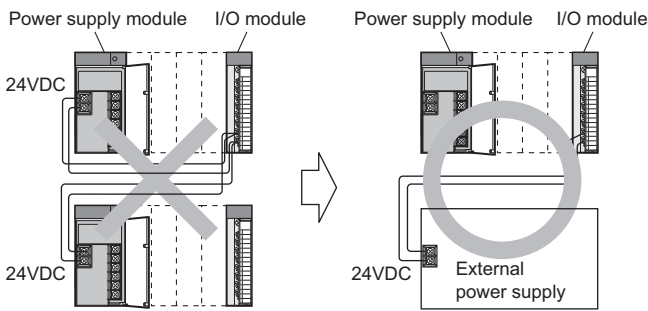

- Do not install the power cables together with the main circuit lines (high voltage and large current) or I/O signal wires (including common lines). Keep a distance of 100mm or more between them.
- A momentary power failure may be detected, or the CPU module or remote head module may be reset because of the lightning surge noise. As a measure against the lightning surge noise, connect a low-voltage surge protective device (SPD) as shown below. Using the low-voltage surge protective device can reduce the influence from the lightning.

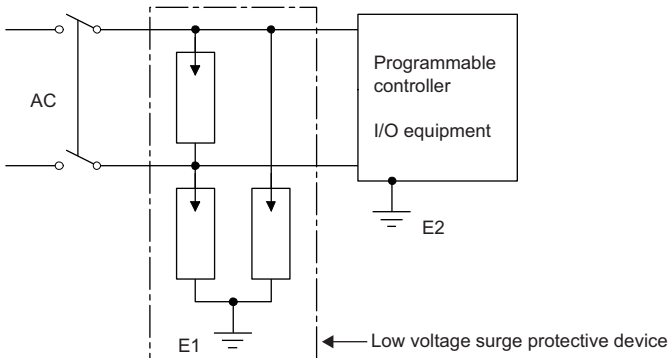

Point 

-
- Separate the ground of the low-voltage surge protective device (E1) from that of a programmable controller (E2).
 - Select a low-voltage surge protective device so that the power supply voltage of when line voltage is maximum does not exceed the maximum allowable circuit voltage of the surge absorber.
 - Select a low-voltage surge protective device for power supply that complies with IEC 61643-11/JIS C5381-11 and meets the requirements of the test class "Class UnitII".
-
- There will be clearances between adjacent modules when the extended temperature range base unit is used, and therefore care should be taken to ensure that cables do not pass between units at wiring.

Wiring to a screw terminal block

This section describes the wiring to an 18-point screw terminal block.

Wiring method

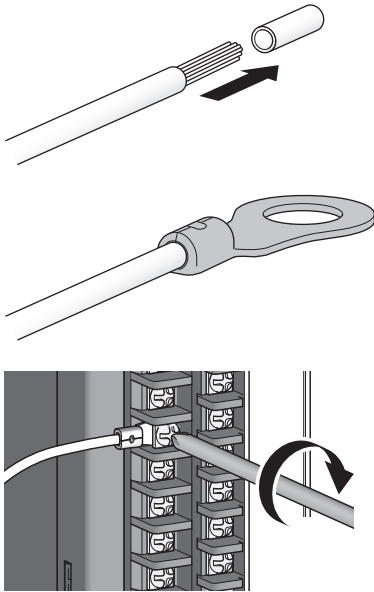

1. Strip the insulating coating of a cable.
2. Connect a solderless terminal to the stripped part of the cable. For applicable solderless terminals, refer to the specifications of each module.
3. Wire the solderless terminal to an 18-point screw terminal block. For the terminal layout, refer to the specifications of each module.

5

Point

Wired cables can be fixed to the 18-point screw terminal block by using a fixing band (width: 3mm, thickness: 1mm or less).

Fix the cables by passing the fixing band (1) to the hole for fixing band (2) as shown below.

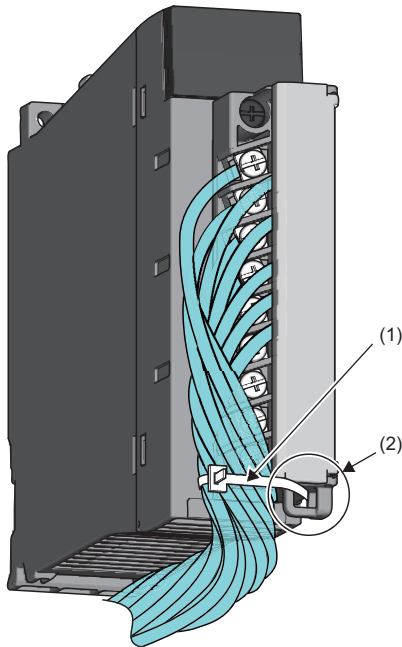

Precautions

- Use UL listed solderless terminals if necessary for UL compliance, and for processing, use a tool recommended by their manufacturer. Note that a solderless terminal with an insulation sleeve cannot be used.
- The wires used for connection to the terminal block must be 0.3 to 0.75mm² in core and 2.8mm or less in outside diameter.
- Wire the input and output lines away from each other.
- When the lines cannot be wire away from the main circuit and power lines, use a batch-shielded cable and ground it on the programmable controller side. In some cases, ground it in the opposite side.

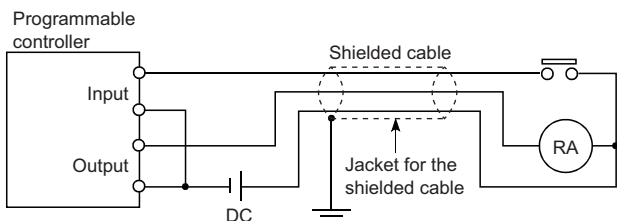

- Ground the piping securely where wiring runs through the piping.
- Install a 24VDC input line away from the 100VAC and 200VAC lines.
- Wiring of 200m or longer will occur the current leakage because of the line capacity, resulting in a fault.
- As a measure against the lightning surge, separate the AC wiring and DC wiring and connect a surge absorber for lightning. (☞ Page 192 Precautions)
- Failure to do so may cause the failure of an I/O device because of the lightning.
- There will be clearances between adjacent modules when the extended temperature range base unit is used, and therefore care should be taken to ensure that cables do not pass between units at wiring.

Wiring to a spring clamp terminal block (Q6TE-18SN)

This section describes the wiring to a spring clamp terminal block.

Wiring method

■Connecting a cable

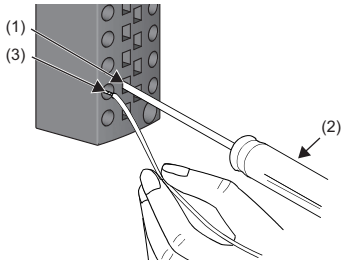

1. Securely insert a spring clamp terminal block tool (2) to a Q6TE-18SN tool insertion opening (square hole) (1) deeply and straight.
2. Insert a cable or bar solderless terminal to the wire insertion opening (round hole) (3) and pull out the spring clamp terminal block tool.
3. Pull the cable or bar solderless terminal lightly, check that it is clamped securely.

■Disconnecting a cable

Securely insert the spring clamp terminal block tool to the Q6TE-18SN tool insertion opening (square hole) deeply and straight, and pull out the bar solderless terminal or cable.

Wiring precautions

- Insert only one wire into the circular shaped hole of the spring clamp terminal block. Inserting two or more wires may result in a poor contact to the terminal part.
- For the wire strip length, satisfy the specifications in this manual. Failure to do so may result in electric shock or short circuit between adjacent terminals because the conductive part. If the wire strip length is too short, it may result in the poor contact to the spring clamp terminal part.
- Do not use the wire soldered the head. Poor contact or insertion-extraction failure to the spring clamp terminal block may occur because of the difference of the solder processing result.
- There will be clearances between adjacent modules when the extended temperature range base unit is used, and therefore care should be taken to ensure that cables do not pass between units at wiring.

Precautions for using a spring clamp terminal block tool

Observe the following precautions for using a spring clamp terminal block tool. Failure to do so may result in the damage to the spring clamp terminal part or resin part of the terminal block.

- Use the dedicated spring clamp terminal block tool.
- Do not insert a bar solderless terminal or cable before inserting the spring clamp terminal block tool to the tool insertion opening.
- Insert the spring clamp terminal block tool to the tool insertion opening straight.

Wiring to a spring clamp terminal block (R60TCTRT2TT2-TS, R60TCRT4-TS)

This section describes the wiring to a spring clamp terminal block.

Wiring method

■Connecting a cable

- Connecting by push-in

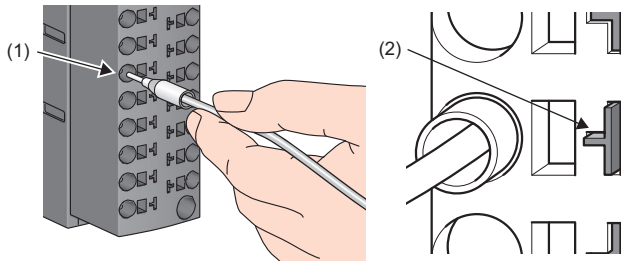

1. Insert a bar solderless terminal into a wire insertion opening (round hole) (1), and push it until the connection check indicator (2) is stuck out.

- Connecting with a spring clamp terminal block tool

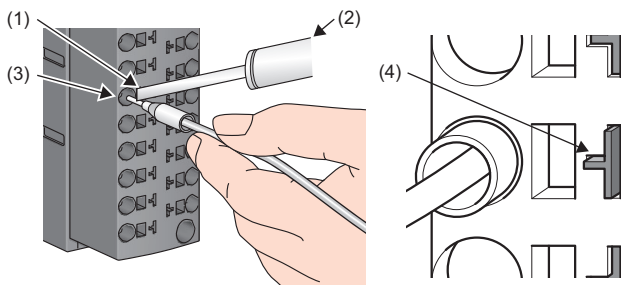

1. Securely and deeply insert a spring clamp terminal block tool (2) into a tool insertion opening (square hole) (1) of the terminal block.
2. Insert a bar solderless terminal into the wire insertion opening (round hole) (3) until the connection check indicator is stuck out, and then pull out the spring clamp terminal block tool.
3. Check that the connection check indicator (4) is stuck out.

Precautions

If the connection check indicator is not stuck out, the bar solderless terminal is not connected completely. Push it securely until the connection check indicator is stuck out.

■Disconnecting a cable

1. Securely and deeply insert a spring clamp terminal block tool into the tool insertion opening (square hole) of the spring clamp terminal block.
2. Pull out the bar solderless terminal.

Wiring precautions

- Strip the cable from the tip to connect a bar solderless terminal at the stripped area. Do not insert the stripped cable as it is into a wire insertion opening. Otherwise, the connection check indicator is not stuck out.
- For the wire strip length, follow the specification of the bar solderless terminal. Use a crimping tool when connecting a bar solderless terminal to a wire.
- Before inserting a bar solderless terminal, check the shape of the wire insertion opening and bar solderless terminal. Also, insert the bar solderless terminal with care so that the bar solderless terminal is in proper orientation.
- If a bar solderless terminal bigger than the wire insertion opening is inserted, the terminal block may be damaged.

Precautions for using a spring clamp terminal block tool

Observe the following precautions for using a spring clamp terminal block tool. Failure to do so may result in the damage to the spring clamp terminal part or resin part of the terminal block.

- Use the dedicated spring clamp terminal block tool.
- Do not insert a bar solderless terminal or cable before inserting the spring clamp terminal block tool to the tool insertion opening.
- Insert the spring clamp terminal block tool to the tool insertion opening straight.

Wiring to a spring clamp terminal block (lever type)

This section describes the wiring to a spring clamp terminal block (lever type).

Precautions

- Use a bar solderless terminal for the wiring to the terminal block. If a stripped wire is inserted to a wire insertion opening, the wire cannot be clamped securely.
- For wire strip length, follow the specifications of the bar solderless terminal used. Use a crimping tool to crimp a bar solderless terminal onto a stranded wire.
- If bar solderless terminals and crimping tools other than those introduced as reference products are used, the terminal can be stuck in the tool and cannot be removed depending on the crimp shape or the material of the terminal. For the reference products, refer to the user's manual for the module used.
- When inserting a bar solderless terminal, ensure that the size and orientation of the terminal are correct to prevent the terminal from getting stuck in or the terminal block damage.

Cable termination method

1. Strip off the sheath of a cable end.

- For the wire strip length, follow the specifications of the bar solderless terminal used.
- A wire that is stripped too long can cause an electric shock or a short circuit between adjacent terminals because the current-carrying part is exposed at the front side of a terminal block.
- A wire that is stripped too short can cause a poor contact to the spring clamp terminal part of a terminal block.

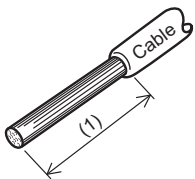

(1) Wire strip length

2. Insert the stripped wire into a bar solderless terminal.

- Use a bar solderless terminal that is appropriate to the size of the wire used.
- When crimping a bar solderless terminal, use an appropriate crimping tool.
- Insert a stripped wire so that it extends out (approximately 0 to 0.5mm) from the metal sleeve part of a bar solderless terminal.

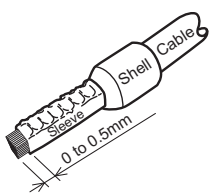

3. Visually check the crimped bar solderless terminal.

Do not use a bar solderless terminal that is not crimped properly or damaged.

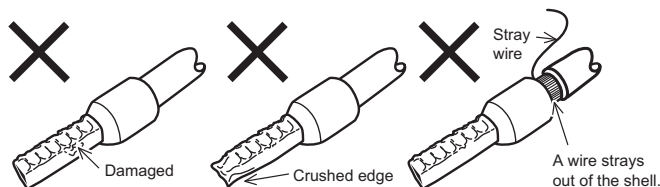

Connecting a cable

Insert a wire with a bar solderless terminal into the wire insertion opening and push the wire. Then, pull the wire lightly and check that it is clamped securely.

When inserting the wire, ensure that the terminal is in the following orientation.

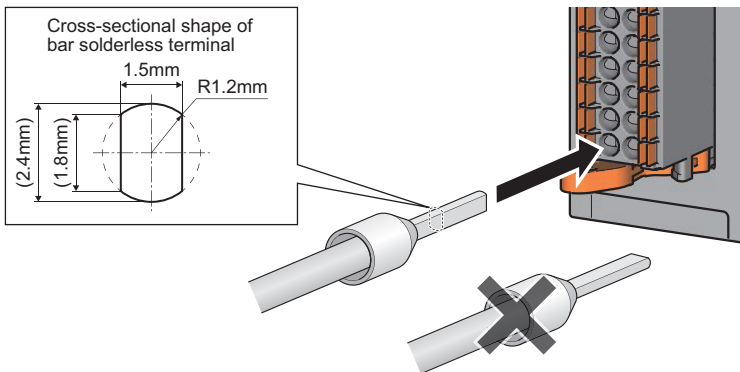

5

Disconnecting a cable

Push the open/close button for the wire to be disconnected using a removal tool. Pull out the wire with the open/close button pushed.

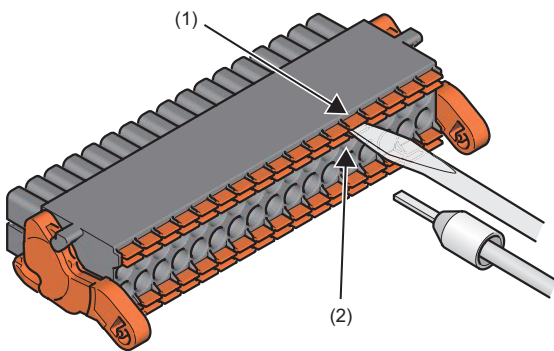

- (1) Open/close button
- (2) Wire insertion opening

Use a removal tool having the shape and size shown below.

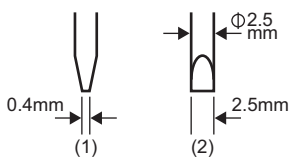

- (1) Side
- (2) Front

Wiring a connector

This section describes how to wire connectors for external devices.

Applicable connectors

The following reference products are the connector types and crimping tool for a module.

■40-pin connectors

Type	Model	Applicable wire size
Soldering type connector (straight type)	A6CON1	0.088 to 0.3mm ² (28 to 22 AWG) (stranded wire)
Crimping type connector (straight type)	A6CON2	0.088 to 0.24mm ² (28 to 24 AWG) (stranded wire)
Soldering type connector (dual purpose (straight/oblique) type)	A6CON4	0.088 to 0.3mm ² (28 to 22 AWG) (stranded wire)

■40-pin connector crimping tool

Manufacturer	Type	Model
OTAX CO., LTD.	Crimping tool	N363TT005H

For how to wire connectors and how to use the crimping tool, contact the manufacturer.

Wiring method

■A6CON1, A6CON4

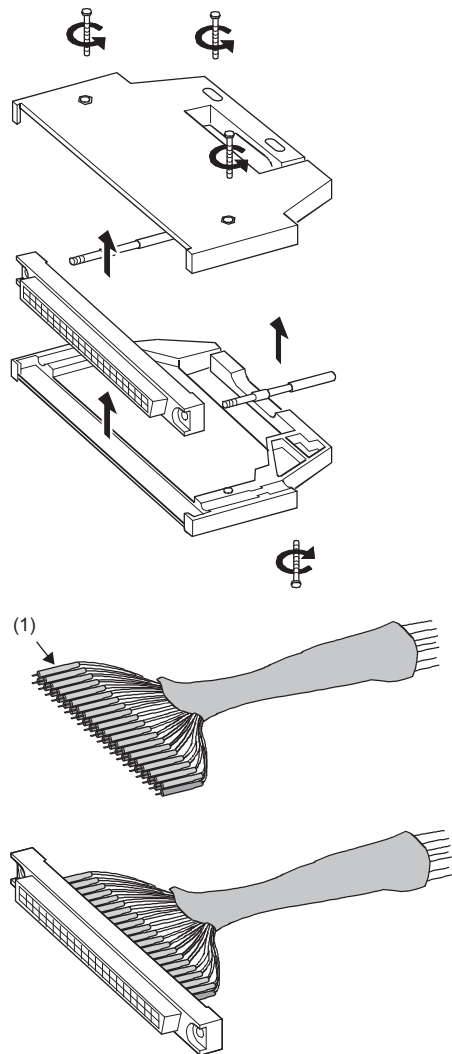

1. Loosen the four fixing screws on the connector and remove the screws. Open the connector cover from the connector side.
2. Solder the wires and coat them with heat shrinkable tubes (1).
3. Check the terminal layout and wire them to the connector. When the connector is plugged into an I/O module, an FG wire needs not to be installed.

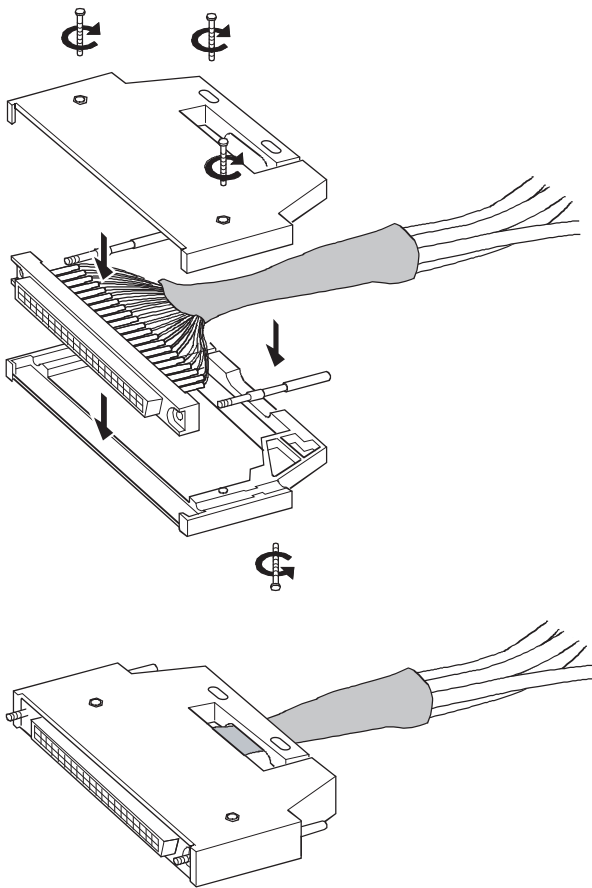

- Place the connector on one side of the connector cover and put the fixing screws through the screw holes. Cover another connector cover onto the connector.

- Tighten the four screws.

■A6CON2

The following table shows the specifications of the N363TT005H used for the A6CON2.

Applicable wire size	Cross-section area of wire	Crimp height	Sheath outside diameter of wire	Length of stripped wire part
AWG24	0.20 to 0.24mm ²	1.25 to 1.30	Φ1.2 or less	3.0 to 4.0
AWG26	0.13 to 0.16mm ²	1.20 to 1.25	Φ1.2 or less	3.0 to 4.0
AWG28	0.088 to 0.096mm ²	1.15 to 1.20	Φ1.2 or less	3.0 to 4.0

Wiring of the A6CON2 requires the special tool.

For how to use and adjust the tool, contact the manufacturer.

Point

Arrangement for a flat cable is in the order of A1 → B1 → A2
 (The following figure shows a connector viewed from the plug-in side.)

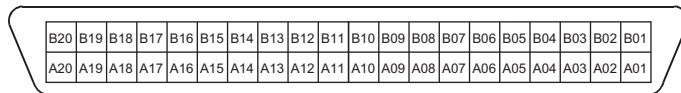

Plugging a connector

■ Installation procedure

1. Plug the connector into the slot on the module.

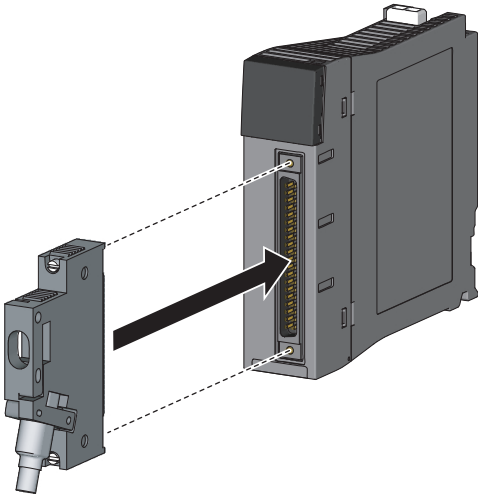

2. Tighten the two connector screws (M2.6) (1).

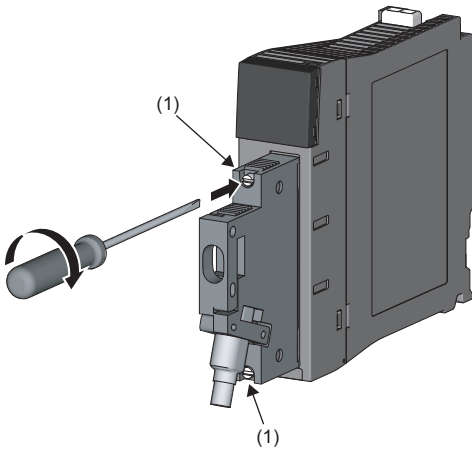

■ Removal procedure

Loosen the two connector screws and pull out the connector from the module straight.

Precautions

- Crimp or solder the connector for an external device (A6CON□) correctly.
- Connect the A6CON□ to the module securely and tighten the two connector screws.
- Tighten the connector screws within the specified torque range.

Screw	Tightening torque range
Connector screw (M2.6)	0.20 to 0.29N·m

- Place the cables in a duct or clamp them. If not, dangling cables may swing or inadvertently be pulled, resulting in malfunction or damage to modules or cables. In addition, the weight of the cables may put stress on modules in an environment of strong vibrations and shocks.
- Use copper wire with a temperature rating of 75°C or higher for the connector.
- Use UL listed connectors if necessary for UL compliance.

Point

To ensure that the connector used maintains EMC and Low Voltage Directives, please refer to the following.

☞ Page 262 EMC and Low Voltage Directives

Even when compliance with the EMC Directive and Low Voltage Directives is not required, configuring the system that complies with the EMC Directive may reduce external noise.

Grounding

Observe the following:

- Provide independent grounding when possible. Ground the FG and LG terminals to the protective ground conductor dedicated to the programmable controller (ground resistance: 100 ohms or less).
- If independent grounding cannot be provided, employ (2) Shared grounding shown below.
- For devices such as servo amplifiers, please ensure that grounding with equipment from different power systems is done in a way that does not affect each other.

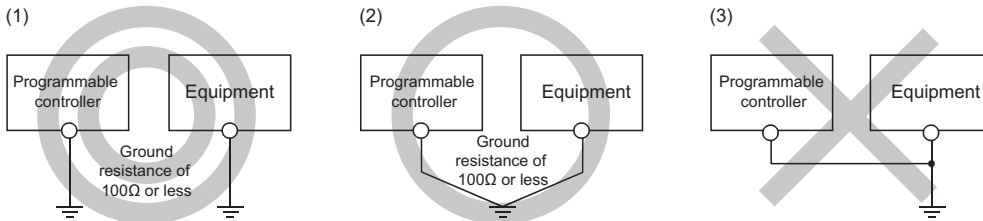

- (1) Independent grounding: Recommended
- (2) Shared grounding: Allowed
- (3) Common grounding: Not allowed

- Use the thickest cable (maximum of 2mm²). Bring the grounding point close to the programmable controller as much as possible so that the ground cable can be shortened.

5.8 Mounting/Removing a Module or Terminal Block

Mounting/removing a module on/from a main base unit or extension base unit

This section describes the procedure for mounting/removing a module on/from a base unit or extension base unit.

Power off a system when mounting/removing the module. Attach a blank cover module (RG60) to each connector where no module is mounted to prevent entry of foreign matter such as dust.

Mounting procedure (with a module fixing hook)

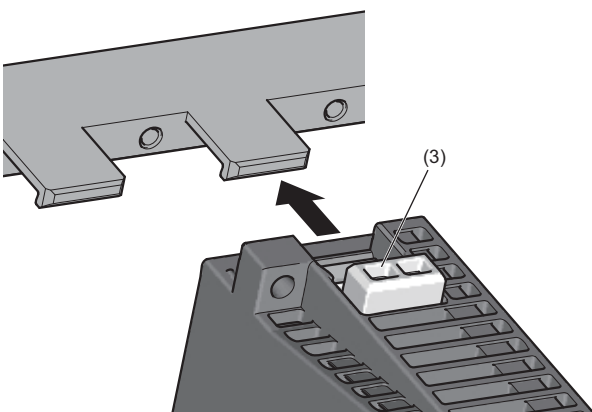
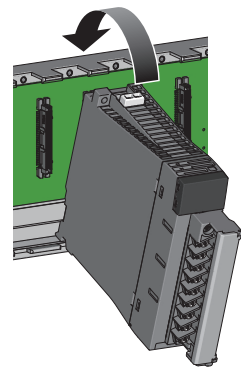
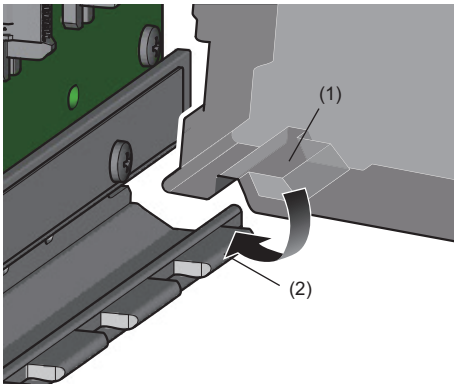

1. When a cap is attached to the module connector of the base unit, remove it.
2. Place the concave part (1) of a module onto the guide (2) of the base unit.
3. Push in the module until the module fixing hook (3) snaps into place.
4. Check that the module fixing hook (3) hangs the base unit and the module is mounted on the base unit securely.

Point

When using the programmable controllers in environments in which they are subject to strong vibrations and shocks, take the following measures:

- Fix the modules to the base unit using screws. (Module fixing screw: M3×12 (sold separately))
- Place the cables connected to the modules in a duct or clump them to prevent the weight of the cables from putting stress on the modules.

■Precautions for installation

- Place the concave part of a module onto the guide of a base unit before mounting a module. Failure to do so may damage the module.
- To mount a MELSECWinCPU module (a module occupying three slots), a connector cover on the second slot must also be removed.

■When the extended temperature range base unit is used

Clearances between adjacent modules are provided on the extended temperature range base unit. Mount modules using the white lines on the circuit board as markers.

Mount the module occupying two slots as shown below

- For the CPU module, align the long edge of the white line on the circuit board with the left side of the module, and then mount on the base unit.

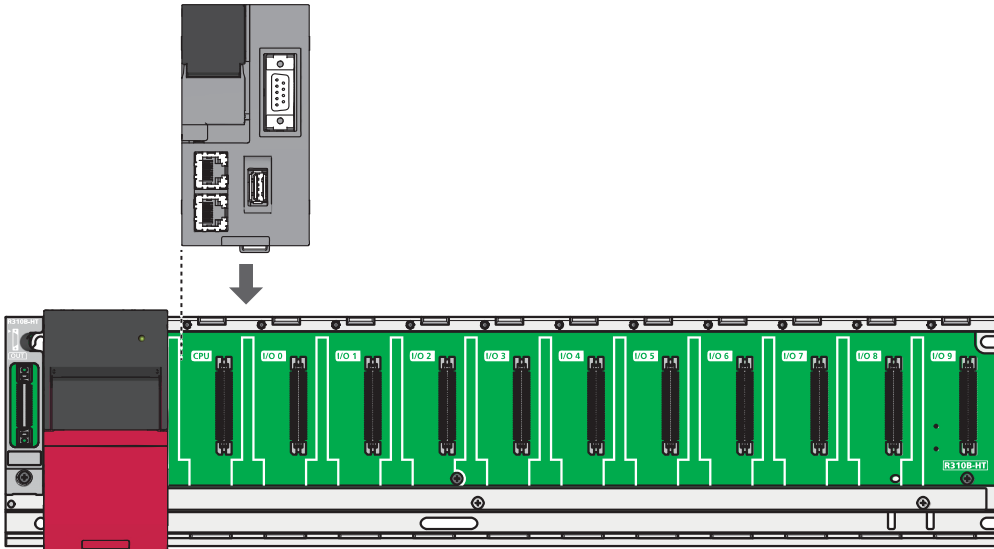

- For the modules other than the CPU module, align the short edge of the white line on the circuit board with the left side of module, and then mount on the base unit.

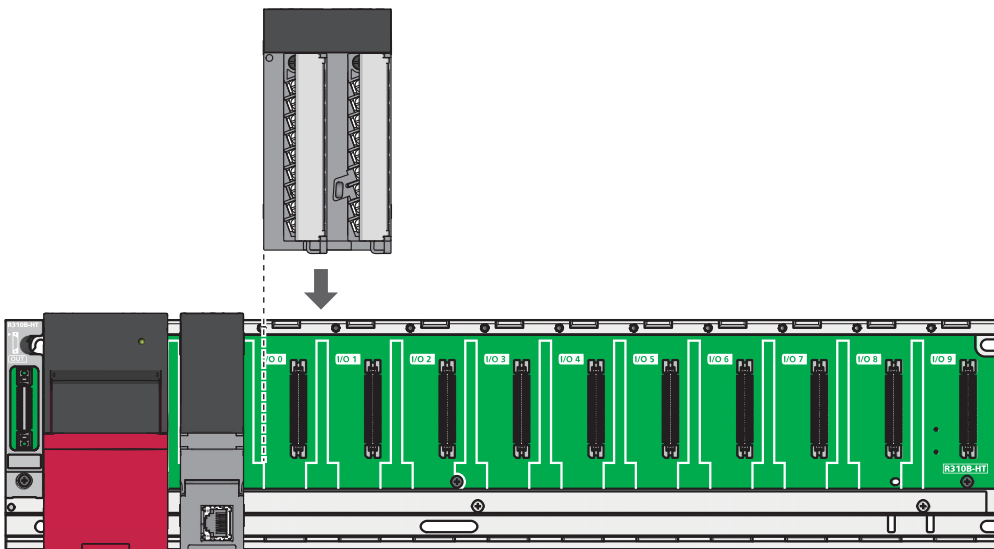

Removal procedure (with a module fixing hook)

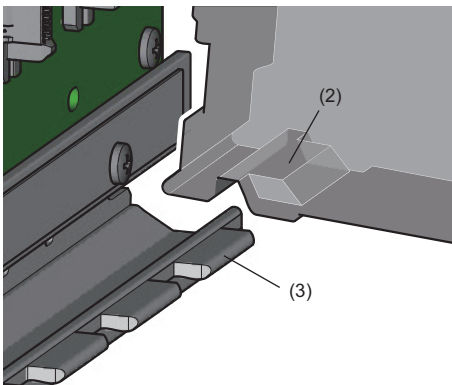
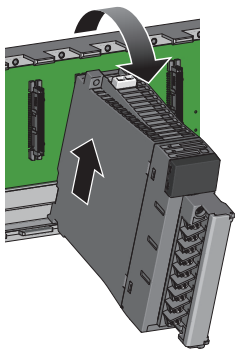
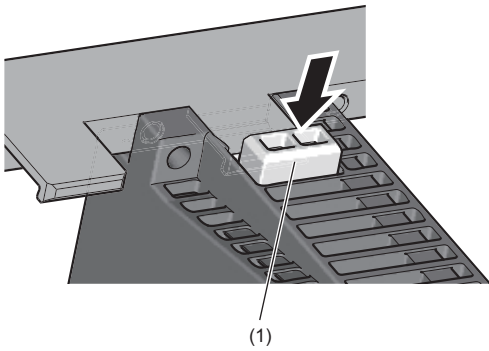

- 1.** Support the module with both hands and securely press the module fixing hook (1) with your finger.
- 2.** Pull the module straight supporting it at its bottom while pressing the module fixing hook (1).
- 3.** While lifting the module, remove the concave part (2) from the guide (3) of the base unit.

Point

- When module fixing screws are used, remove the screws first and module from the base unit. Failure to do so may damage the module.
- The module surface temperature may be high immediately after power-off. When the module is removed, pay attention to the burn injury.

Mounting procedure (without a module fixing hook)

The module without a module fixing hook is equipped with a module fixing screw on its case. To properly use the module fixing screw and the base unit, observe following instructions when mounting or removing the module.

- When securing units, align a screwdriver with the screw slot and tighten slowly.
- Do not use an electric screwdriver.
- If foreign matter is sticking to the module fixing screw, remove it before mounting the module.

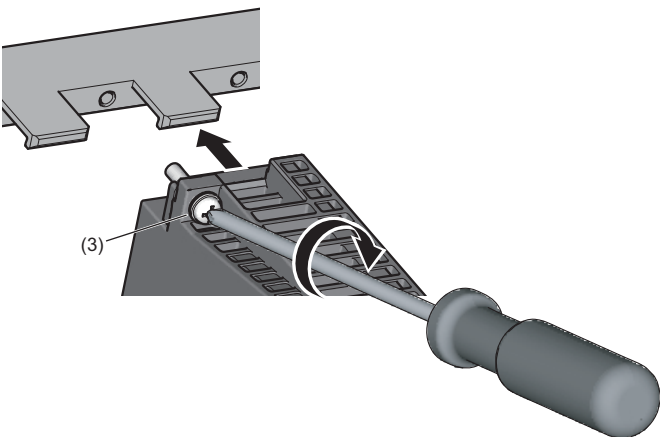
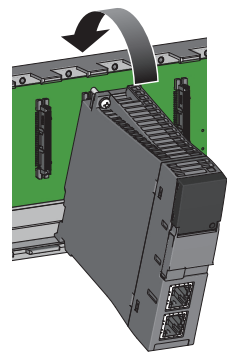
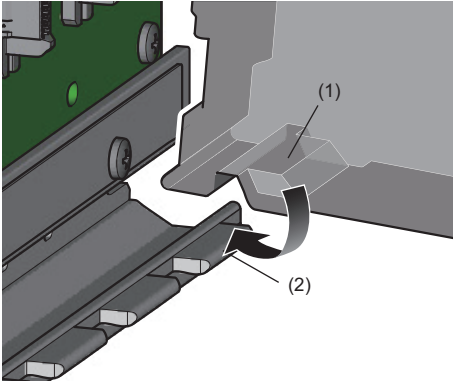

- 1.** If a cap is attached to the base unit module connector, remove the cap.
- 2.** Place the concave part (1) of a module onto the guide (2) of the base unit.
- 3.** Push in the module and tighten the module fixing screw (3) to fix the module on the base unit. (tightening torque: 0.36 to 0.48N·m)
- 4.** Make sure that the module is securely mounted.

5

Point

Use the module fixing screw that is equipped with the module. When using the programmable controllers in environments in which they are subject to strong vibrations and shocks, place the cables connected to modules in a duct or clump them to prevent the weight of the cables from putting stress on the modules.

■Precautions for installation

Place the concave part of a module onto the guide of a base unit before mounting a module. Failure to do so may damage the module.

Removal procedure (without a module fixing hook)

1. Loosen the module fixing screw (1).

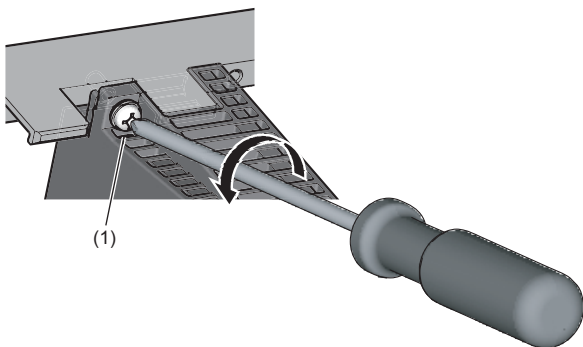

2. Pull the module toward supporting it at its bottom.
3. While lifting the module, remove the concave part (2) from the guide (3) of the base unit.

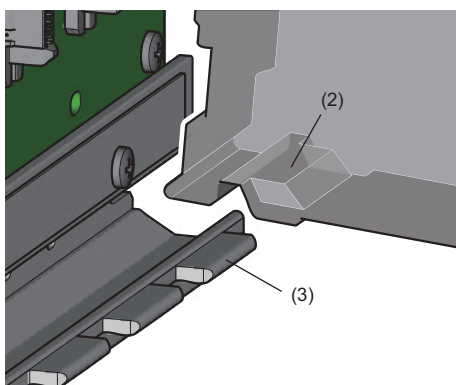
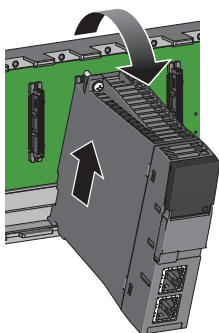

Point

- The module surface temperature may be high immediately after power-off. When the module is removed, pay attention to the burn injury.
- When removing the module, make sure that the module fixing screw is loosened up completely. Failure to do so may damage the module.
- If the module fixing screw is broken, replace the case of the module. When replacing the case, please consult your local Mitsubishi representative.

Mounting/removing a module on/from a RQ extension base unit

This section describes the procedure for mounting/removing a module on/from a RQ extension base unit.

Power off a system when mounting/removing the module. Attach a blank cover module (QG60) to each connector where no module is mounted to prevent entry of foreign matter such as dust.

Mounting procedure

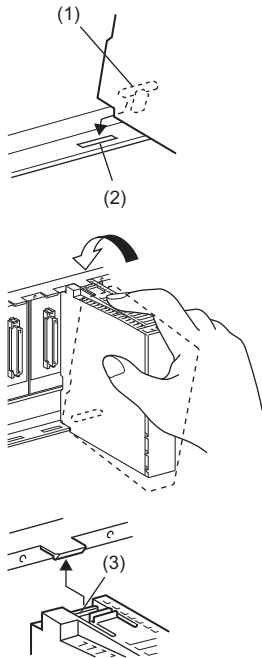

1. When a cap is attached to the module connector of the base unit, remove it.
2. Insert the module fixing projection (1) into the module fixing hole (2).
3. Push in the module until the module fixing hook (3) snaps into place.
4. Check that the module fixing hook (3) hangs the base unit and the module is mounted on the base unit securely.

5

Point

When using the programmable controllers in environments in which they are subject to strong vibrations and shocks, take the following measures:

- Fix the modules to the base unit using screws. (Module fixing screw: M3×12 (sold separately))
- Place the cables connected to the modules in a duct or clump them to prevent the weight of the cables from putting stress on the modules.

■Precautions for installation

Insert the module fixing projection to the module fixing hole properly before mounting module. Failure to do so may damage the module.

Removal procedure

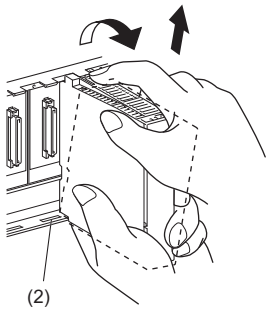
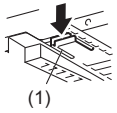

- 1.** Support the module with both hands and securely press the module fixing hook (1) with your finger.
- 2.** Pull the module straight supporting it at its bottom while pressing the module fixing hook (1).
- 3.** While lifting the module, remove the module fixing projection part from the module fixing hole (2).

Point

- When module fixing screws are used, remove the screws first and module from the base unit. Failure to do so may damage the module.
- The module surface temperature may be high immediately after power-off. When the module is removed, pay attention to the burn injury.

Installing/removing a terminal block

This section describes the removal and installation procedure of the terminal block of a module.

Removal procedure

■ Removing an 18-point screw terminal block

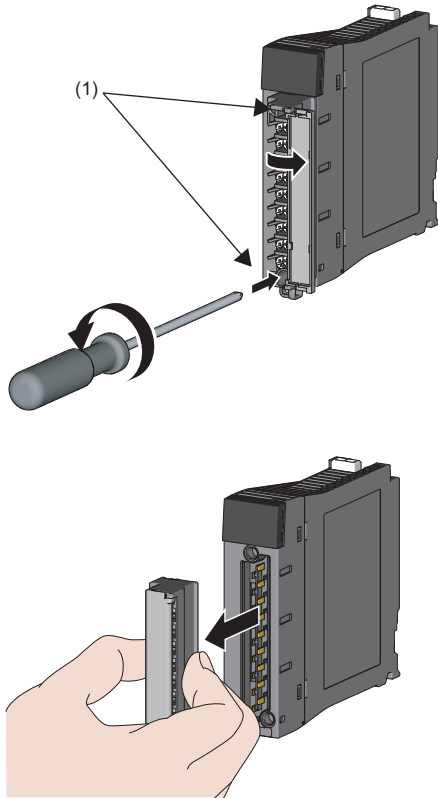

1. Open the terminal cover and loosen two terminal block mounting screws (1).

2. Remove the terminal block.

■ Removing a spring clamp terminal block (R60TCTRT2TT2-TS, R60TCRT4-TS)

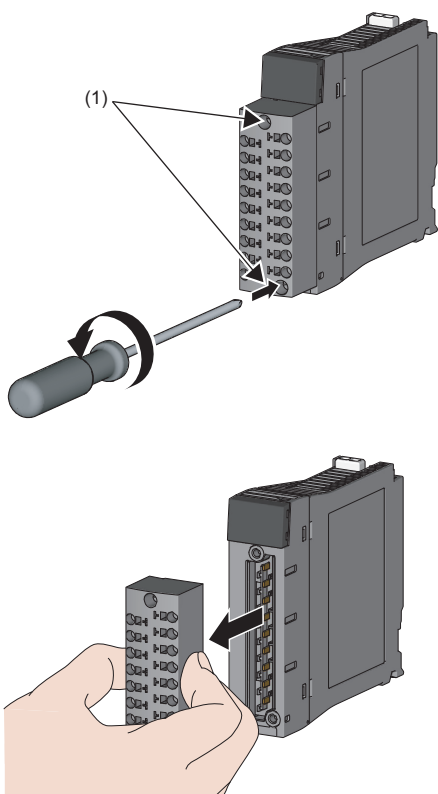

1. Loosen two terminal block mounting screws (1).

2. Remove the terminal block.

■Removing a spring clamp terminal block (lever type)

Turn the lever to the release lever position and remove the terminal block from the module.

Installation procedure

■Installing an 18-point screw terminal block

After installing the terminal block, tighten two terminal block mounting screws.

■Installing a spring clamp terminal block (Q6TE-18SN)

1. Remove the protective cap from the Q6TE-18SN.

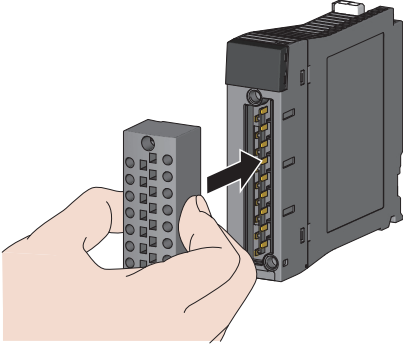

2. Install the Q6TE-18SN to the module and tighten the terminal block mounting screws. (tightening torque: 0.66 to 0.89N·m)

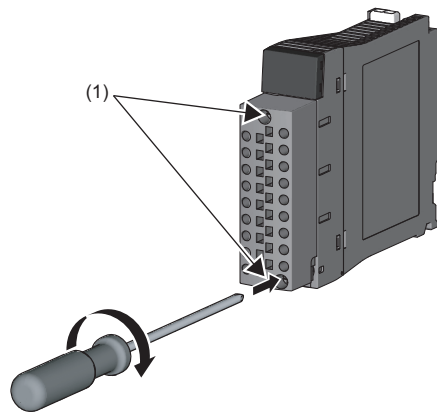

■Installing a spring clamp terminal block (R60TCTRT2TT2-TS, R60TCRT4-TS)

After installing the terminal block, tighten two terminal block mounting screws.

■Installing a spring clamp terminal block (lever type)

Move the lever to the lock lever position and push the terminal block. When the terminal block is fully pushed in, the hook of the lever hangs on the module and fits the terminal block.

Point

The terminal block can be inserted with the lever locations other than the lock lever position.
After insertion, check that the lever is in the lock lever position.

■ Lock and release lever positions

To make it easy to install and remove the terminal block, a three-stage positioning stopper is attached so that the lever does not freely turn around.

When installing or removing the terminal block, move the lever to the lock or release lever position.

- Figure viewed from the module top surface: When pulling the terminal block
- 1. Release lever position**

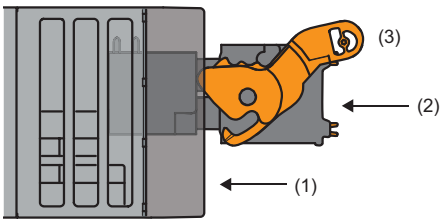

This lever position shows the state in which the terminal block has been completely pulled out from the module. Turn from the lock lever position to the release lever position and lift the terminal block from the module.

- Figure viewed from the module top surface: When insertion of the terminal block has completed

- 2. Lock lever position**

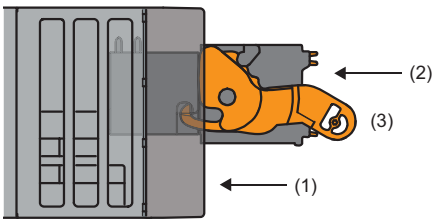

This lever position shows the state in which the terminal block completely fits the module. Check the lock lever position and pull the terminal block lightly to check that the module completely fits the terminal block.

- (1) Front part of a module
- (2) Terminal block
- (3) Lever position

Handling precautions

This section describes precautions for the handling of a module.

- Do not drop or apply strong shock to the module, SD memory card, extended SRAM cassette, battery-less option cassette, terminal block connector, and pin connector.
- Do not disassemble or modify the modules, extended SRAM cassettes, and battery-less option cassette. Doing so may cause failure of the module.
- Do not place any objects that generate strong magnetic force near the battery-less option cassette. Placing an object which generates strong magnetic force within a few centimeters from the battery-less option cassette may cause malfunction or failure of this cassette.
- Tighten each screw within the following torque range.

Screw	Tightening torque range
Module fixing screw (M3×12)	0.36 to 0.48N·m
Terminal block screw (M3)	0.42 to 0.58N·m
Terminal block mounting screw (M3.5)	0.66 to 0.89N·m
Connector screw (M2.6)	0.20 to 0.29N·m
Terminal screw (M4) of a power supply module	1.02 to 1.38N·m
Terminal screw (M3.5) of a power supply module	0.66 to 0.89N·m

- Mount a power supply module on the slot for the module (except the base unit which is not required the power supply module). Failure to do so cannot guarantee the operation because of the unstable voltage even if the module which is mounted on the base unit operates.
- Do not install extension cables together with the main circuit lines (high voltage and large current). Keep a distance of 100mm or more between them.
- Malfunction of the module may occur if the foreign matter such as the conductive dust contacts with the module surface other than front during the operation. Protect modules by attaching a blank cover module (RG60) to each connector where no module is mounted.

6 MAINTENANCE AND INSPECTION

This chapter describes items that must be maintained or inspected daily or periodically to properly use a programmable controller in optimal condition at all times.

When using the C Controller module, refer to the following.

📖 MELSEC iQ-R C Controller Module User's Manual

When using a MELSECWinCPU module, refer to the following.

📖 MELSEC iQ-R MELSECWinCPU Module User's Manual

6.1 Daily Inspection

This section describes items that must be inspected daily.

Item	Inspection Item	Inspection method	Judgment criteria	Corrective action	
1	Mounting of the base unit	Looseness of the base unit	Check that mounting screws are not loose and the cover is not dislocated.	The screws and cover must be fixed. Retighten the screws.	
2	Mounting of the module	Looseness of the module	Check that the module is mounted and the module fixing hook is fixed securely.	The module must be mounted and the module fixing hook must be fixed. Fix the module fixing hook securely.	
3	Connection status	Terminal screw loosening	Check for the terminal screw loosening.	The terminal screws must not be loose. Retighten the terminal screws.	
		Clearance between the solderless terminals	Check for the clearance between the solderless terminals.	The proper clearance must be provided between solderless terminals. Provide the proper clearance.	
		Connector loosening	Check for the cable connector loosening.	The cable connector must not be loose. Connect the connector with no loosening securely.	
4	LED status	POWER LED (power supply module)	Check that the LED is on.	The LED must be on.	When the judgment criteria is not satisfied, refer to the following and take the corrective action. 📖 User's Manual (Application) for the module used
		READY LED and RUN LED	Check that the LED is on.	The LED must be on.	
		ERROR LED, ERR LED, P ERR LED, and L ERR LED	Check that the LED is off.	The LED must be off.	
		BATTERY LED (CPU modules other than the R00CPU, R01CPU, and R02CPU)	Check that the LED is off.	The LED must be off.	
		USER LED (CPU module)	Check that the LED is off.	The LED must be off.	
		I/O indicator LED (I/O module)	Check that the LED is on or off.	The LED turns on when I/O signals are on. The LED turns off when I/O signals are off.	

6.2 Periodic Inspection

This section describes items that must be inspected one or two times every six months to one year.

When the equipment has been relocated or modified, or wiring layout has been changed, inspect the items.

Item	Inspection Item	Inspection method	Judgment criteria	Corrective action	
1	Environment	Ambient temperature ^{*1}	Measure the temperature by using a thermometer.	0 to 55°C ^{*2}	Create the environment that satisfies the judgment criteria
		Ambient humidity	Measure the humidity by using a hygrometer.	5 to 95%RH	
		Atmosphere	Measure corrosive gases.	No corrosive gases	
2	Power supply voltage check	Measure a voltage between the 100-240VAC terminals and/or between the 24VDC terminals.	85 to 264VAC	Change the supply power.	
			15.6 to 31.2VDC		
3	Installation	Looseness and rattling	Touch the module to check for the looseness and rattling.	The module must be mounted securely.	Retighten the screws. If the module is loose, fix the module with screws.
		Attachment of dirt and foreign matter	Check visually.	Dirt and foreign matter must not be attached.	Remove them. Clean the programmable controller.
4	Battery	Check the BATTERY LED on the CPU module.	The LED must be off.	Replace the battery when the LED is on.	
		Check the length of term after purchasing the battery.	The battery must not be used more than five years.	Replace the battery if it has been used more than 5 years.	
		Check that SM51 or SM52 is turned off using an engineering tool.	SM51 or SM52 must be off.	Replace the battery when SM51 or SM52 is on.	
5	Module diagnostics	Check an event history using the module diagnostics.	An event history must not be updated.	 GX Works3 Operating Manual	
6	Maximum scan time	Check the values of SD526 and SD527 using an engineering tool.	Maximum scan time must be within the allowable range given in the specification of the system.	Specify causes that increase the scan time. Check the operation status of the trigger signal that passes through a loop if loop positions exist in the sequence program.	

*1 The temperature in the control panel installed a programmable controller is called the ambient temperature.

*2 When an extended temperature range base unit is used, each module can be used in the environment of 0 to 60°C.

Battery replacement procedure

When the life of the battery comes to an end, follow the procedure below to replace the battery.

Keep the programmable controller on for ten minutes or longer before removing the battery from the CPU module. Power off the programmable controller, and then replace the battery.

Replacement procedure for the Q6BAT

Replace the battery within the backup power time (three minutes).

The CPU module holds the data on the memory for three minutes by the capacitor even after the battery is removed. Note that the data on the device/label memory may be erased if the replacement time exceeds the backup power time.

1. Back up the program and data.
2. Power off the programmable controller.
3. Remove the CPU module from the base unit.
4. Open the battery cover (5) located on the bottom of the CPU module.
5. Disconnect the connector plug of the Q6BAT from the jack of the CPU module. When disconnecting the connector, hold the connector part so that the cables are not damaged.
6. Remove the Q6BAT from the battery cover.
7. Set a new Q6BAT to the cover in the right direction (with the positive terminal of the battery facing the connector holder).
8. Securely insert the connector plug (1) of the Q6BAT to the connector jack of the CPU module (2). Set the connected connector (3) to the connector holder (4) of the cover.
9. Close the battery cover (5).

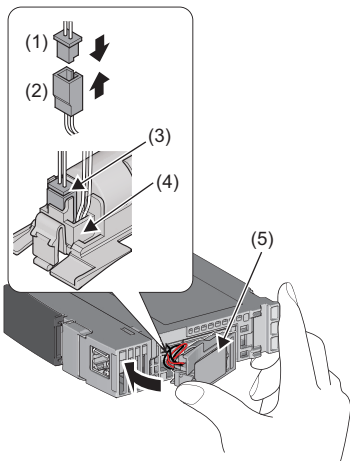

- (1) Connector plug of the Q6BAT
- (2) Connector jack of the CPU module
- (3) Connector (The connector plug of the Q6BAT is connected to the connector jack of the CPU module.)
- (4) Connector holder of the battery cover
- (5) Battery cover on the bottom of the CPU module

Point

If the connected connector (3) becomes detached from the connector holder (4) of the cover, this may interfere with the components inside the module when the cover is closed, and the components may be damaged.

10. Mount the CPU module back on the base unit.
11. Power on the programmable controller.
12. Using the engineering tool, check that SM51 (Battery low latch) is off. If SM51 is off, the battery has been replaced successfully. If SM51 is on, the battery may not be installed properly. Repeat the procedure from step 2. If SM51 remains on, the possible cause is a hardware failure of the battery. Perform the procedure with a different battery.

Replacement procedure from the Q6BAT to the Q7BATN-SET/Q7BAT-SET

Replace the battery within the backup power time (three minutes).

The CPU module holds the data on the memory for three minutes by the capacitor even after the battery is removed. Note that the data on the device/label memory may be erased if the backup power time is exceeded.

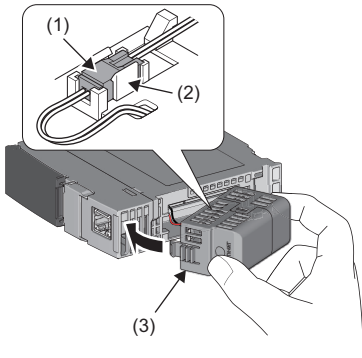

1. Back up the program and data.
2. Power off the programmable controller.
3. Remove the CPU module from the base unit.
4. Open the battery cover located on the bottom of the CPU module.
5. Disconnect the connector plug of the Q6BAT from the jack of the CPU module. When disconnecting the connector, hold the connector part so that the cables are not damaged.
6. Securely insert the connector plug of the Q7BATN-SET/Q7BAT-SET to the jack of the CPU module.
7. Set the connector (1) into the connector stopper (2) of the battery holder.
8. Attach the Q7BATN-SET/Q7BAT-SET (3) to the CPU module.*¹

*¹ Be careful not to let the battery cable get caught between the Q7BATN-SET/Q7BAT-SET and the CPU module when attaching the battery.

Replacement procedure for the Q7BATN/Q7BAT

Replace the battery within the backup power time (three minutes).

The CPU module holds the data on the memory for three minutes by the capacitor even after the battery is removed. Note that the data on the device/label memory may be erased if the backup power time is exceeded.

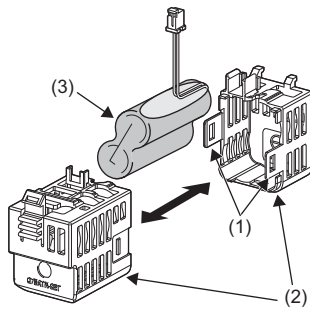

1. Back up the program and data.
2. Power off the programmable controller.
3. Remove the CPU module from the base unit.
4. Remove the battery holder.
5. Disconnect the connector plug of the Q7BATN/Q7BAT from the jack of the CPU module. When disconnecting the connector, hold the connector part so that the cables are not damaged.
6. Disengage the latches on both sides of the battery holder to disassemble the holder into two, and remove the Q7BATN/Q7BAT.
7. Insert the new Q7BATN/Q7BAT into the holder in the correct orientation, checking the positive/negative terminal markings. (For the Q7BATN, insert it at a slight angle as shown in the figure.) Reassemble the battery holder, making the battery cable come out of the hole in the holder connection. (Push the holder parts in until they click.)
8. Securely insert the connector plug of the Q7BATN/Q7BAT to the jack of the CPU module (4). Set the connector into the connector stopper (5) of the battery holder.
9. Attach the battery holder (6) to the CPU module.
10. Mount the CPU module back on the base unit.
11. Power on the programmable controller.
12. Using the engineering tool, check that SM51 (Battery low latch) is off.

If SM51 is off, the battery has been replaced successfully.

If SM51 is on, the battery may not be installed properly. Repeat the procedure from step 2. If SM51 remains on, the possible cause is a hardware failure of the battery. Perform the procedure with a different battery.

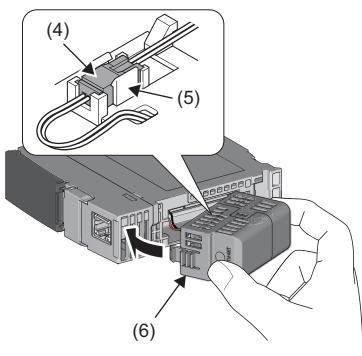

Replacement procedure for the FX3U-32BL

Replace the battery within the backup power time (10 days).

Note that the clock data may be erased if the backup power time is exceeded.

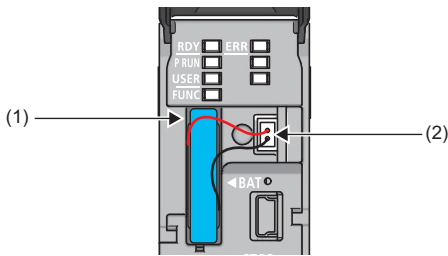

1. Power off the programmable controller.
2. Open the LED cover located on the front of the CPU module.
3. Take the used battery out of the battery compartment (1) and disconnect the battery from the battery connector (2).
4. Connect the lead connector of the new battery to the battery connector (2) with the correct orientation. Insert the new battery to the battery compartment (1).
5. Close the LED cover located on the front of the CPU module.
6. Power on the programmable controller.
7. Using the engineering tool, check that SM51 (Battery low latch) is off.

If SM51 is off, the battery has been replaced successfully.

If SM51 is on, the battery may not be installed properly. Repeat the procedure from step 2. If SM51 remains on, the possible cause is a hardware failure of the battery. Perform the procedure with a different battery.

6

Replacement procedure of redundant power supply modules

The following describes the replacement procedure for a redundant power supply module in the online state (power is on). (Assuming that the other redundant power supply module is normally operating)

1. Check which redundant power supply module is to be replaced with either of the following methods.
 - System monitor of an engineering tool
 - SM151 (Power supply module failure detection) or SD151 (Power supply failure detection status)
2. Power off the input power supply of the redundant power supply module to be replaced. (A continuation error occurs.)*¹
3. Replace the redundant power supply module with a new one.

When replacing a redundant power supply module, pay full attention to the mounting/removing procedure. (☞ Page 194 Mounting/Removing a Module or Terminal Block)

4. Power on the input power supply of the new redundant power supply module.
5. Check that the POWER LED turns on.*²

*¹ When a remote head module is mounted on the right of the redundant power supply module, a continuation error is not detected by turning on and holding SB000F (Clear error).

*² When SB000F (Clear error) of the remote head module has turned on, turn it off.

Point

- If one redundant power supply module has failed, remove the module from the base unit and replace it with a normal one as soon as possible (within 14 days as a guide). Even if a redundant power supply module does not fail, replacement is recommended after five years.
- In a redundant power supply system, a continuation error occurs when either of redundant power supply modules has failed. Clear the error after replacing the defective redundant power supply module with a new one.
- If a power supply module other than a redundant power supply module is mounted, a continuation error occurs.

APPENDICES

Appendix 1 Checking Production Information and Firmware Version

Checking methods

This section describes how to check the production information and firmware version of a module.

Checking on the module

■Rating plate

The rating plate is located on the side of the module.

The production information (16 digits) of the module is shown on the SERIAL field.

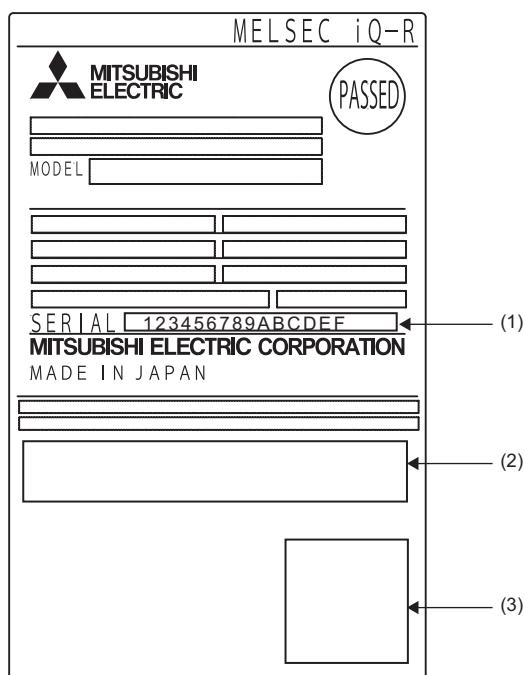

- (1) Production information (16 digits)
- (2) Relevant regulation standards
- (3) QR code

■Production information marking

The production information (16 digits) of the module is printed on the marking on the front (at the bottom) of the module.



- R00CPU, R01CPU, R02CPU



Checking with the engineering tool

■ Product information list

The firmware version ^{*1} and the production information (16 digits) of the module can be checked on the "Product Information List" window.

*1 For the RnENCPU, each firmware version of the CPU part and network part can be checked.

☞ [Diagnostics] ⇒ [System Monitor] ⇒ [Product Information List] button

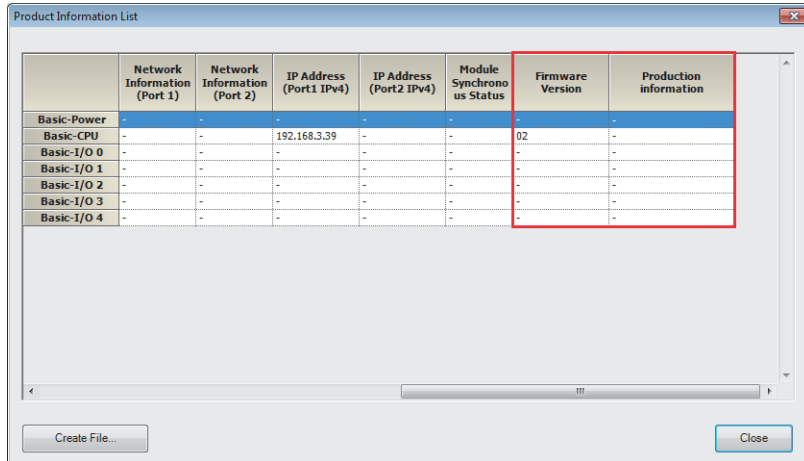

	Network Information (Port 1)	Network Information (Port 2)	IP Address (Port1 IPv4)	IP Address (Port2 IPv4)	Module Synchronus Status	Firmware Version	Production information
Basic-Power	-	-	-	-	-	-	-
Basic-CPU	-	-	192.168.3.39	-	-	02	-
Basic-I/O 0	-	-	-	-	-	-	-
Basic-I/O 1	-	-	-	-	-	-	-
Basic-I/O 2	-	-	-	-	-	-	-
Basic-I/O 3	-	-	-	-	-	-	-
Basic-I/O 4	-	-	-	-	-	-	-

■ Module diagnostics

The production information (16 digits) of the module can be checked on the "Module Diagnostics" window.

☞ [Diagnostics] ⇒ [Module Diagnostics]

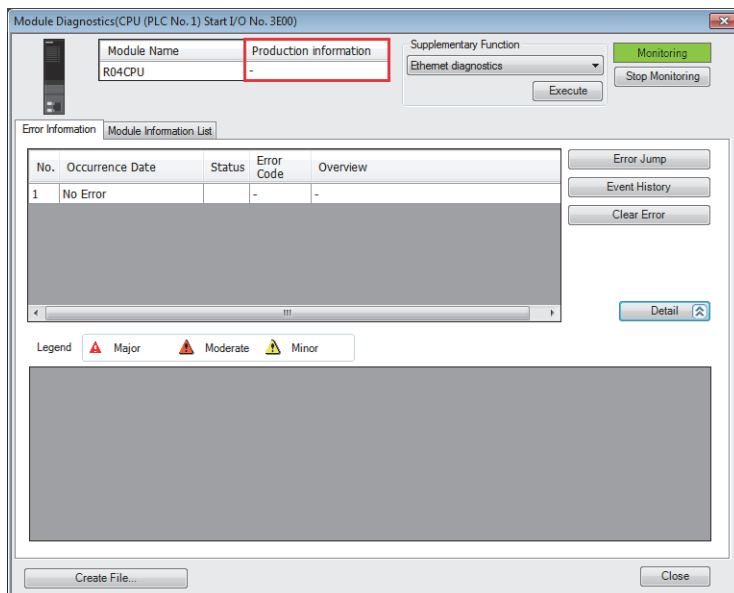

Module Diagnostics(CPU (PLC No.1) Start I/O No. 3E00)

Module Name: R04CPU
Production information: -

Supplementary Function: Ethernet diagnostics
Execute

Monitoring: Stop Monitoring

Error Information: Module Information List

No.	Occurrence Date	Status	Error Code	Overview
1	No Error	-	-	-

Legend: Major (Red Triangle), Moderate (Yellow Triangle), Minor (Green Triangle)

A

Appendix 2 Firmware Update Function

This function enables users to update the firmware versions of modules by using firmware update files. (For the firmware update file, please consult your local Mitsubishi representative.) The following two methods for updating firmware are available.

Update method	Description
Update using an engineering tool	The firmware versions of multiple modules can be changed at a time by using an engineering tool.
Update using an SD memory card	The firmware version of a module can be changed just using an SD memory card. Dedicated software is not required.

Point

Confirm the safety of the system before updating the firmware version. If the firmware version of CPU module is updated with being connected to the other system through a network, a system error (stop error) may occur.

Update using an engineering tool

The firmware versions of multiple modules can be changed at a time by using an engineering tool.

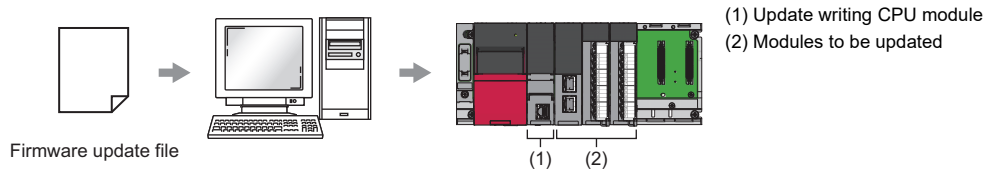

The firmware version of a module is updated by writing the firmware update information for updating firmware to the module from the CPU module. A CPU module that writes the information is called an update writing CPU module.

Update writing CPU modules and modules to be updated

This section lists the models of update writing CPU modules and modules to be updated.

■ Update writing CPU module

The following CPU modules can be used as update writing CPU modules.

- Programmable controller CPU
- Process CPU

■ Modules to be updated

The following indicates the update writing CPU module types.

- Rn(1): R00CPU, R01CPU, R02CPU
- Rn(2): R04CPU, R08CPU, R16CPU, R32CPU, R120CPU
- RnEN: RnENCPU (CPU part)/RnENCPU (network part)
- RnP: Process CPU

Modules to be updated			Firmware version of the update writing CPU module	Version of the engineering tool
Product	Model	Firmware version		
Programmable controller CPU ^{*1*4}	R00CPU	"01" or later	<ul style="list-style-type: none"> • Rn(1): "14" or later • Rn(2): "46" or later • RnEN: "46"/"42" or later • RnP: "24" or later 	1.060N or later
	R01CPU, R02CPU	"14" or later		
	R04CPU, R08CPU, R16CPU, R32CPU, R120CPU	"46" or later		
	R04ENCPU, R08ENCPU, R16ENCPU, R32ENCPU, R120ENCPU	"46"/"42" or later		
Process CPU	R08PCPU, R16PCPU, R32PCPU, R120PCPU	"24" or later		1.065T or later
Redundant function module	R6RFM	"01" or later	RnP: "24" or later ^{*5}	
CC-Link IE Controller Network module	RJ71GP21-SX, RJ71GP21S-SX	"01" or later ^{*7}	<ul style="list-style-type: none"> • Rn(1): "14" or later • Rn(2): "46" or later • RnEN: "46"/"42" or later • RnP: "24" or later 	1.060N or later
CC-Link IE Field Network master/local module	RJ71GF11-T2			
Ethernet-equipped module	RJ71EN71			
Serial communication module ^{*3*4}	RJ71C24, RJ71C24-R2, RJ71C24-R4	"01" or later	<ul style="list-style-type: none"> • RnP: "24" or later 	
CC-Link IE TSN master/local module	RJ71GN11-T2 ^{*2} , RJ71GN11-SX ^{*2} RJ71GN11-EIP ^{*8}			
CC-Link system master/local module	RJ61BT11		<ul style="list-style-type: none"> • Rn(1): "18" or later • Rn(2): "50" or later • RnEN: "50"/"46" or later • RnP: "24" or later 	1.090U or later
MELSECNET/H network module	RJ71LP21-25		<ul style="list-style-type: none"> • Rn(1): "18" or later • Rn(2): "50" or later • RnEN: "50"/"46" or later • RnP: "24" or later 	1.063R or later
	RJ71BR11		<ul style="list-style-type: none"> • Rn(1): "18" or later • Rn(2): "50" or later • RnEN: "50"/"46" or later • RnP: — 	1.095Z or later
GPIB interface module	RJ71GB91		<ul style="list-style-type: none"> • Rn(1): "18" or later • Rn(2): "50" or later • RnEN: "50"/"46" or later • RnP: "24" or later 	1.072A or later
Analog-digital converter module	R60AD4, R60AD18, R60ADV8			1.065T or later
Channel isolated analog-digital converter module (with signal conditioning function)	R60AD6-DG			
High speed analog-digital converter module	R60ADH4			
HART-enabled analog-digital converter module	R60ADI8-HA			1.070Y or later
Digital-analog converter module	R60DA4, R60DA18, R60DAV8			1.065T or later
High speed digital-analog converter module	R60DAH4			
Channel isolated RTD input module	R60RD8-G			1.072A or later
Channel isolated thermocouple input module	R60TD8-G			
Channel isolated temperature/micro voltage input module	R60TRD4-G			1.120A or later
Channel isolated pulse input module	RD60P8-G			1.070Y or later
Flexible high-speed I/O control module	RD40PD01			1.065T or later
Positioning module ^{*4}	RD75P2, RD75P4, RD75D2, RD75D4	"06" or later ^{*6}		
Recorder module ^{*4}	RD81RC96	"11" or later	<ul style="list-style-type: none"> • Rn(1): "29" or later • Rn(2): "62" or later • RnEN: "62"/"59" or later • RnP: — 	1.110Q or later
Camera recorder module ^{*4}	RD81RC96-CA	"10" or later		

- *1 Update simultaneously the CPU part and network part of RnENCPU.
- *2 The model with the main base unit can be updated.
- *3 When using the following update writing CPU modules, set the control CPU of the module to the CPU No.1.
 - R00CPU, R01CPU, and R02CPU with firmware version of "17" or earlier
 - Programmable controller CPU (excluding the R00CPU, R01CPU, and R02CPU) with firmware version of "49" or earlier
- *4 For the precautions, refer to the User's Manual for the module used.
- *5 Only a Process CPU (redundant mode) can be used as an update writing CPU module.
- *6 A module whose 3rd and 4th digits from the left of the production information are "13" or earlier are excluded.
- *7 When the firmware version is "52" or later, the firmware versions of the update writing CPU module are as follows:
 - Rn(1): "18" or later
 - Rn(2): "50" or later
 - RnEN: "50"/"46" or later
 - RnP: "24" or later
- *8 Ensure that the configuration shown in the "Update Firmware" window has been written to the update writing CPU module before updating the firmware version of this module.

Point 

To update the firmware version of CPU module not available for the update using an engineering tool, use an SD memory card. ( Page 228 Update using an SD memory card)

The firmware version of R00CPU is updated by using models other than the R00CPU as the update writing CPU module.

System configuration

The following figure shows a configuration example of the system.

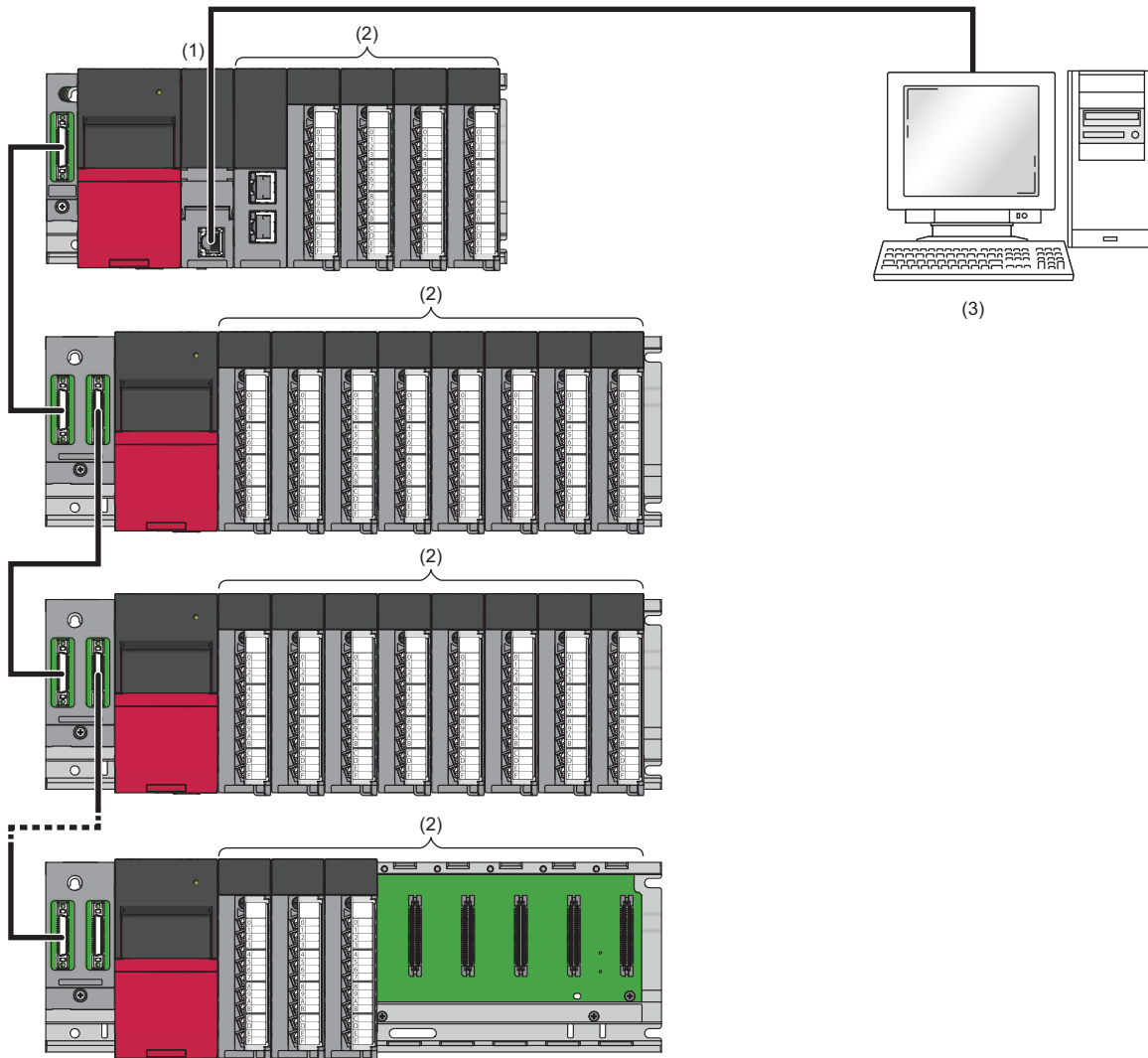

(1) Update writing CPU module

(2) Modules to be updated

(3) Engineering tool

- Mount the update writing CPU module on the CPU slot, and mount the modules to be updated on the slot of No.0 and later. (☞ Page 212 Update writing CPU modules and modules to be updated)
- The firmware versions of 65 modules can be updated in a single CPU system or multiple CPU system. The firmware version of the update writing CPU module only can be updated. In a redundant system, the module mounted to the main base unit can be updated. (The module cannot be updated via a network such as a module of the remote station.)
- Connect the engineering tool and update writing CPU module using a USB or Ethernet (Ethernet port direct connection/ connection via hub).

Ex.

When one CPU module and three intelligent function modules are targeted

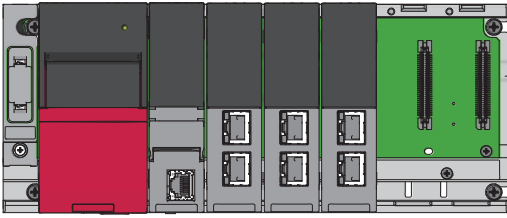

Ex.

In a multiple CPU system, when two CPU modules and four intelligent function modules are targeted

The intelligent function modules controlled by other CPU modules than the host CPU module can be targeted.

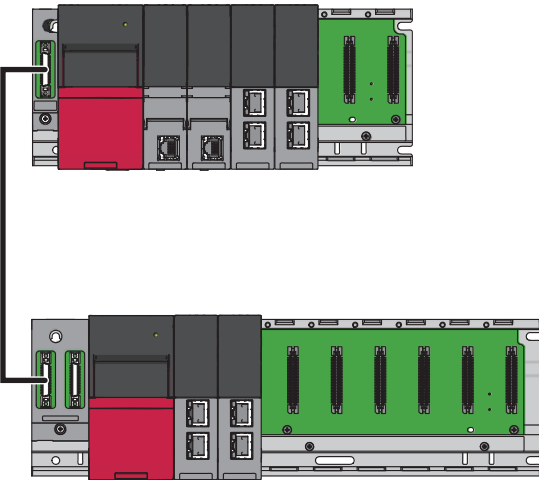

Ex.

When only the update writing CPU module is targeted

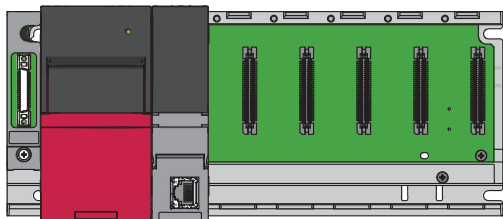

Ex.

In a redundant system, when one CPU module^{*1}, one redundant function module, and four network modules are targeted

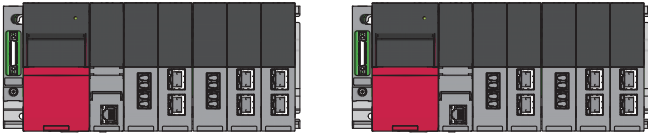

*1 In a redundant system, a Process CPU (redundant mode) is used as an update writing CPU module.

Ex.

In a redundant system with redundant extension base unit, when modules on extension base units are targeted (only when the extension base units are connected to the control system)

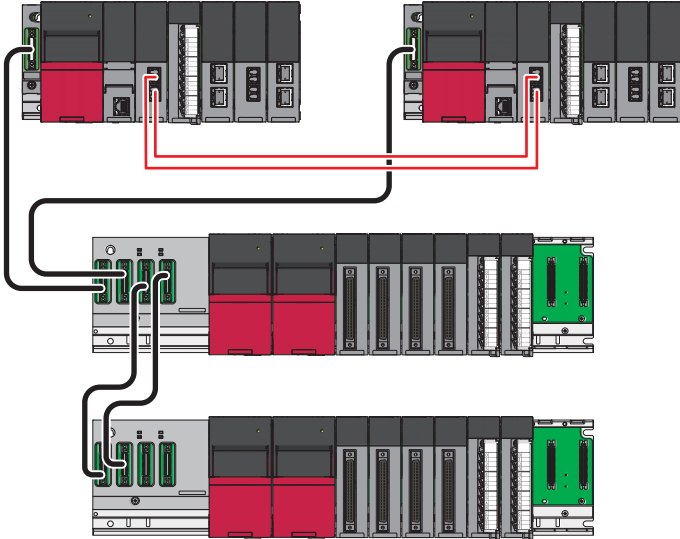

A

Update procedure

■Preparation

Point

For the preparation for an update in a redundant system, refer to the following.

☞ Page 220 Preparation (in a redundant system)

1. From your local Mitsubishi representative, obtain firmware update information for the model where the firmware update will be executed.

Ex.

For the RnCPU and Process CPU

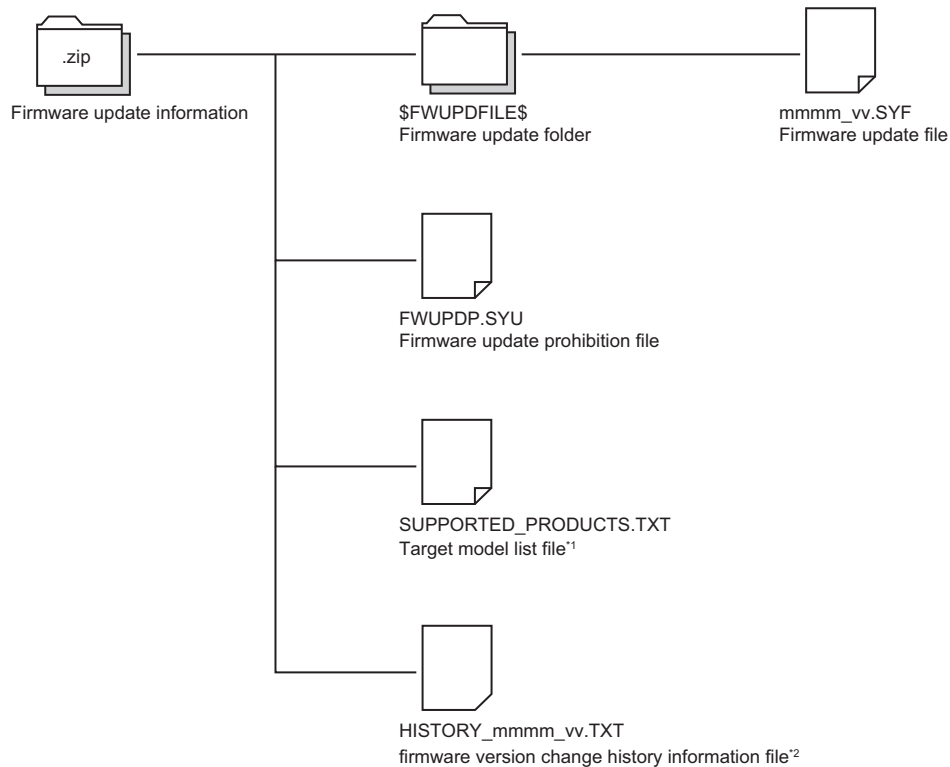

1 A model name list of the target models of the obtained firmware update information file (.zip) are included.

*2 A version change history of the firmware is included. This file is stored for the following models.

- The R00CPU, R01CPU, and R02CPU with firmware version "26" or later
- The RnCPU (excluding the R00CPU, R01CPU, and R02CPU) with firmware version "59" or later
- The RnPCPU with firmware version "39" or later

Ex.

For the RnENCPU

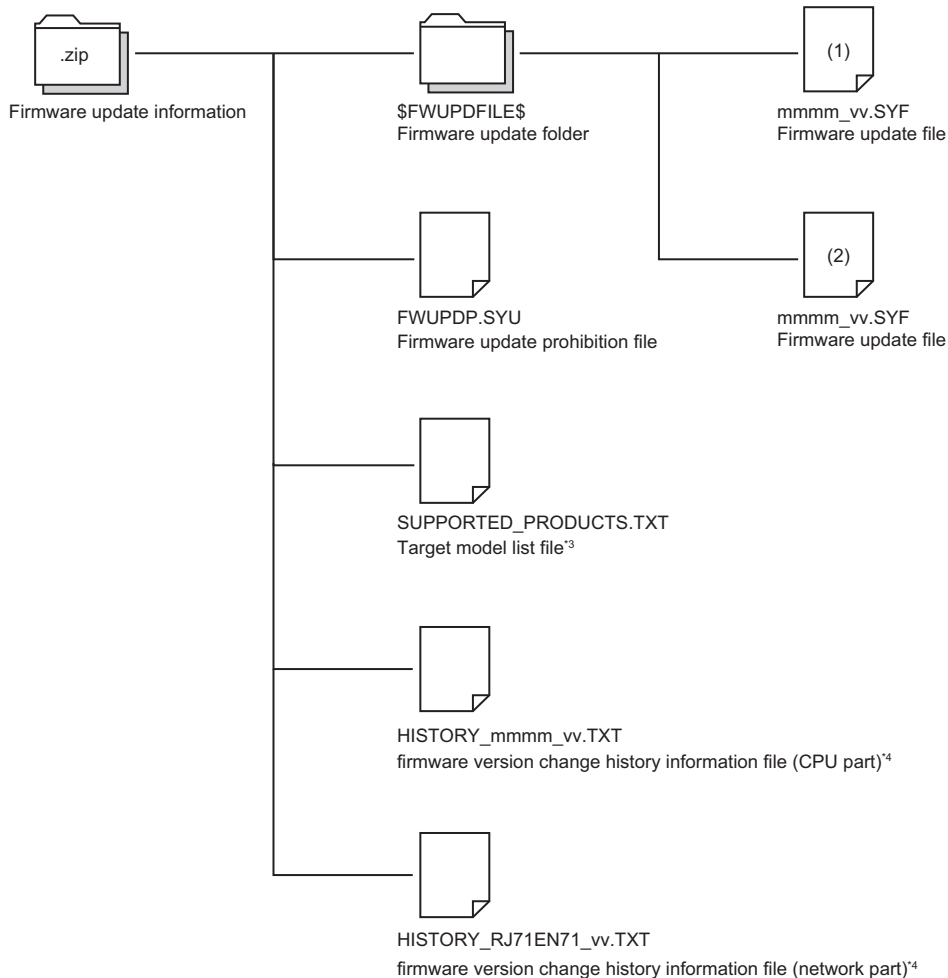

(1) For the CPU part

(2) For the network part

3 A model name list of the target models of the obtained firmware update information file (.zip) are included.

*4 A version change history of the firmware is included. This file is stored for the following models.

· The RnENCPU with firmware version "59" or later

2. Unzip the firmware update information (ZIP file). mmmm of the firmware update file represents a model name and vv of the firmware update file represents a firmware version.
3. Connect the engineering tool and update writing CPU module using a USB or built-in Ethernet (Ethernet port direct connection/connection via hub).
4. Check that the devices other than the CPU module and the programmable controller that execute the update function stop. (Power off the other systems and devices connecting the programmable controller. If the systems or devices cannot be powered off, unplug the communication cable of them.)
5. Check that no function is executed on the update writing CPU module.
6. Check that the file operations (such as the write to programmable controller, online change, and file transfer function) are not executed on the modules to be updated and those not to be updated. (Starting the firmware update during file operations may result in corruption of the file.)
7. Clear the setting for firmware update prohibition if it has been set. (☞ Page 224 Setting for firmware update prohibition)
8. Check that the stop error in the update writing CPU module and any error in the module to be updated do not occur.
9. The data such as programs and parameters are backed up. (In a multiple CPU system, the data of the CPU module of No.2 or later are backed up.)

A

■Preparation (in a redundant system)

This section describes the preparation for an update in a redundant system.

1. From your local Mitsubishi representative, obtain firmware update information for the model where the firmware update will be executed. (For examples of the folder structure, refer to Page 218 Preparation.)
2. Unzip the firmware update information (ZIP file). mmmm of the firmware update file represents a model name and vv of the firmware update file represents a firmware version.
3. Connect the engineering tool and update writing CPU module using a USB or built-in Ethernet (Ethernet port direct connection/connection via hub).

Whether to stop the system control	Procedure
When updating the firmware version without stopping the system control	To update the firmware versions of modules in the control system, turn on SM1646 (System switching by a user) and switch the system to the standby system.*1 Stop the standby system. Unplug the tracking cable of the standby system as well as the communication cables and wires of the other systems and devices connected to the standby system.*2*3
When updating the firmware version with the system control stopped	Set the system to be updated to the control system. Set "Specify Redundant CPU" in the connection destination settings to "Not Specified" and connect the engineering tool and the CPU module of the control system. Stop the control system and power off the standby system.

- *1 In a redundant system with redundant extension base unit, the firmware versions of the modules on extension base units cannot be updated while control of the redundant system is operating. To update them, follow the procedure for updating the firmware version with the system control stopped.
- *2 In the network configuration of CC-Link IE Controller Network and CC-Link IE Field Network, wait for ten seconds or more after unplugging the tracking cable.
- *3 When "Control System Start-up Setting (Input (X))" is set to "Enable", turn off external input signals until the tracking cable is connected because the system may be started up as the control system at the completion of the firmware update.
4. Check that the devices other than the CPU module and the programmable controller that execute the update function stop. (Power off the other systems and devices connecting the programmable controller. If the systems or devices cannot be powered off, unplug the communication cable of them.) When the firmware update is executed to the control system, the system control of the updated module stops. Before executing the firmware update, check the following: The system to be updated has stopped; and the communication cables and wires of other systems, which are connected to the system to be updated via networks, has been disconnected.
 5. Check that no function is executed on the update writing CPU module.
 6. Check that the file operations (such as the write to programmable controller, online change, and file transfer function) are not executed on the modules to be updated and those not to be updated. (Starting the firmware update during file operations may result in corruption of the file.)
 7. Clear the setting for firmware update prohibition if it has been set. (☞ Page 224 Setting for firmware update prohibition)
 8. Check that the stop error in the update writing CPU module and any error in the module to be updated do not occur.
 9. The data such as programs and parameters of the module in the system to be updated is backed up.

■ Operation of engineering tool

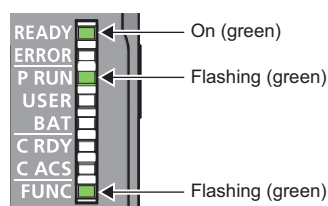
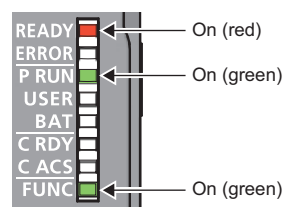
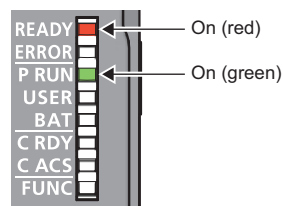
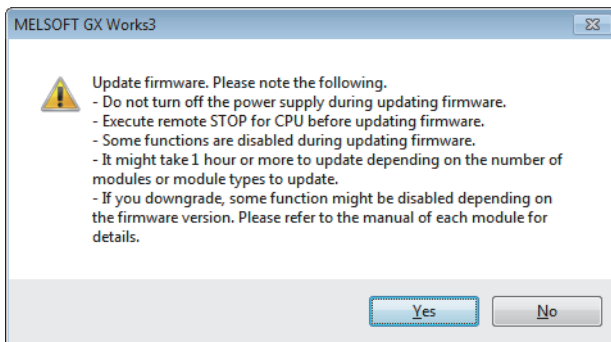
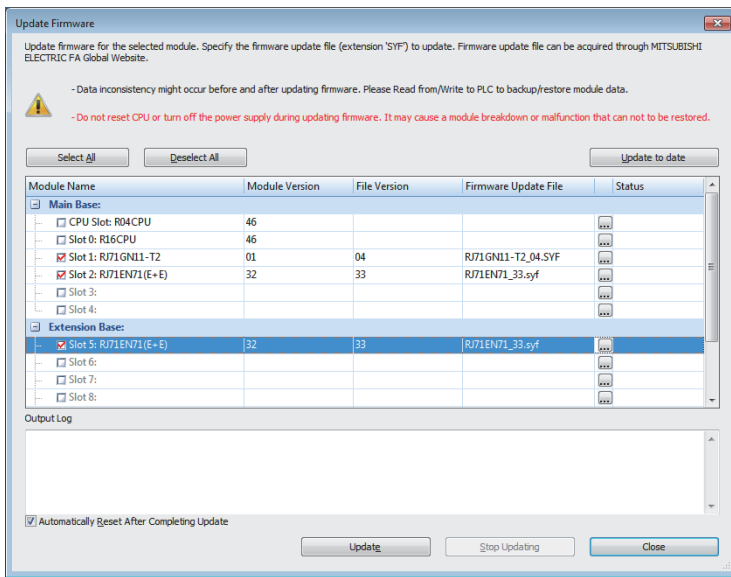

1. Open the "Update Firmware" window from the engineering tool.

[Tool] ⇨ [Firmware Update]

2. Check the checkbox for the module to be updated.^{*1*3} (Only the target module to be updated can be selected. (Page 212 Update writing CPU modules and modules to be updated))

3. Click the [...] button for the module to be updated to select the firmware update file (*.SYF).

4. After the completion of firmware update, the CPU module is reset automatically. Uncheck the checkbox not to be reset the CPU module automatically.^{*2}

5. Click the [Update] button, displaying the precautions on firmware update. Click the [Yes] button to execute the firmware update.

6. The update status during the firmware update is checked on the "Update Firmware" window in the engineering tool and the LED indication on the update writing CPU module. For details on LED indications, refer to the following. Every module specified to be updated, whether the firmware update is completed successfully or completed with an error, is updated.

When the update status is "in standby" or "in transferring", the READY LED turns on in red and the PROGRAM RUN LED turns on in green.

When the update status is "in writing", the READY LED turns on in red, and the PROGRAM RUN LED and FUNCTION LED turn on in green.

When the update status is "update completion", the READY LED turns on in green, and the PROGRAM RUN LED and FUNCTION LED flash in green.

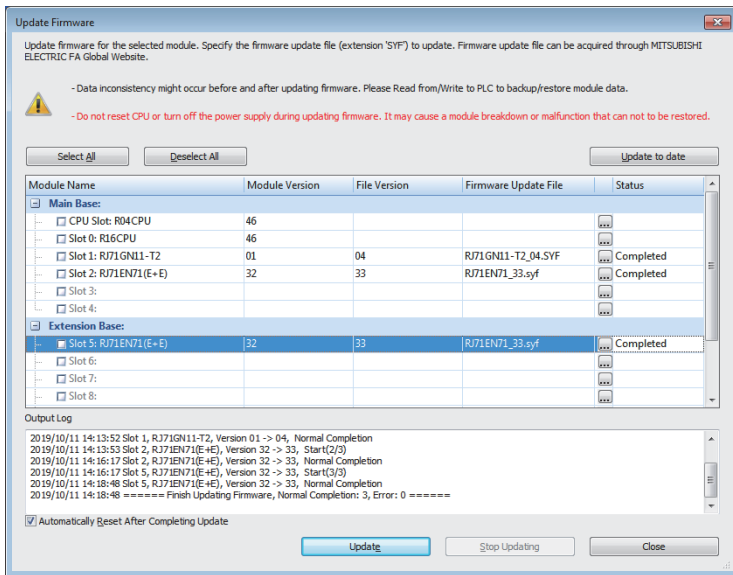

7. After the firmware update is completed, the automatic reset window or the manual reset window is displayed. Click the [OK] button. When the manual reset is selected, reset the module manually.

8. Check the result of firmware update in the "Status" column on the "Update Firmware" window. The detailed information can be checked on "Event History".

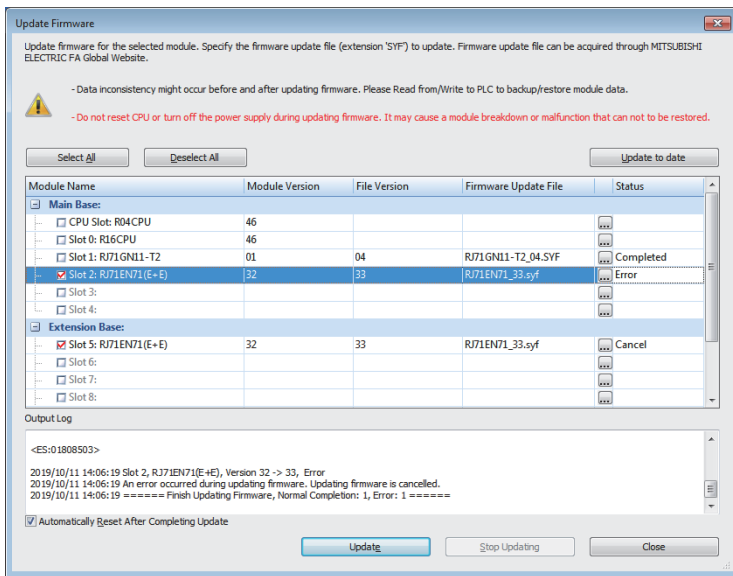

9. When an error occurs, check the error code on "Event history".

MESECC iQ-R CPU Module User's Manual (Application)

10. The backed up programs and parameters are restored.

For how to restore the data in a redundant system, refer to the following. (Page 223 Procedure to restore the prepared backup data in a redundant system).

11. Check the system operation.

In a redundant system, check it switching the systems as needed.

- *1 If a module cannot be selected even though there is the firmware update information for it, update the engineering tool to the latest version and try again.
- *2 To execute the remote RESET function, use the remote operation function of the engineering tool. In addition, set "Remote Reset Setting" to "Enable" in the "CPU Parameter" in advance.
- *3 Some modules may be reset while the firmware update is being executed.
- *4 A stop error may occur after reset, depending on the control/standby system startup settings. The systems are not switched in this case. Check the connection of the tracking cables and reset the system where the firmware update has been executed.

■ Procedure to restore the prepared backup data in a redundant system

The following table shows the procedures.

Whether to stop the system control	Procedure
When updating the firmware version without stopping the system control	<p>Connect the tracking cable and restore the backed up programs and parameters to the standby system.</p> <p>Connect the communication cables and wires of the other systems and devices, and run the standby system.</p> <p>When updating the firmware versions of modules in the control system, turn on SM1646 (System switching by a user) and switch the system to the standby system.*1</p> <p>Unplug the tracking cables and connect the standby system and the engineering tool.</p> <p>Check that the standby system is in the STOP state, then execute the firmware update. (Return to procedure 1.)</p>
When updating the firmware version with the system control stopped	<p>Restore the backed up programs and parameters to the control system.</p> <p>Restart both systems simultaneously.</p> <p>When executing the firmware update to the standby system, unplug the tracking cable and connect the standby system and the engineering tool.</p> <p>Check that the standby system is in the STOP state, then execute the firmware update. (Return to procedure 1.)</p>

*1 A stop error may occur after reset, depending on the control/standby system startup settings. The systems are not switched in this case. Check the connection of the tracking cables and reset the system where the firmware update has been executed.

■ When the update writing CPU module does not start up due to update failure

Update the firmware version of the update writing CPU module using an SD memory card. (👉 Page 228 Update using an SD memory card)

Restriction

The R00CPU and intelligent function modules are not available for the update using an SD memory card. Please consult your local Mitsubishi representative.

Setting for firmware update prohibition

This section describes how to prohibit the firmware update.

To prohibit the firmware update, write a firmware update prohibition file to the CPU module and set a file password.

1. Using an engineering tool, write the firmware update prohibition file (FWUPDP.SYU) to the "\$MELPRJ\$" folder in the data memory of the CPU module. The firmware update prohibition file (FWUPDP.SYU) is included in the firmware update information obtained for the preparation. (☞ Page 218 Preparation)

☞ [Online] ⇒ [User Data] ⇒ [Write]

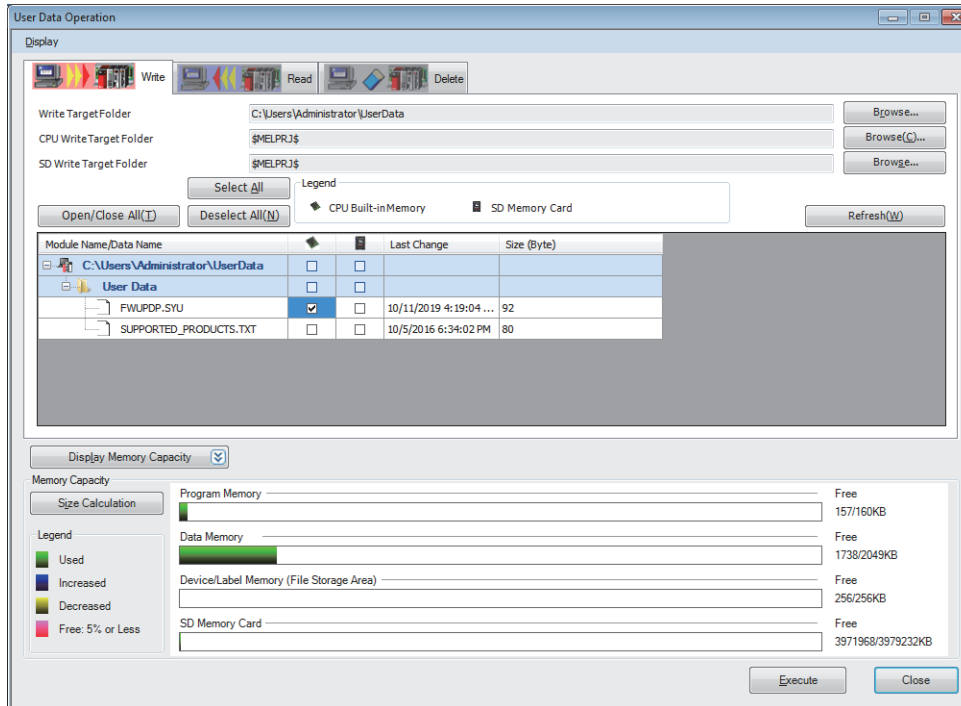

2. Using the engineering tool, set a file password to the firmware update prohibition file.

☞ [Project] ⇒ [Security] ⇒ [File Password Setting]

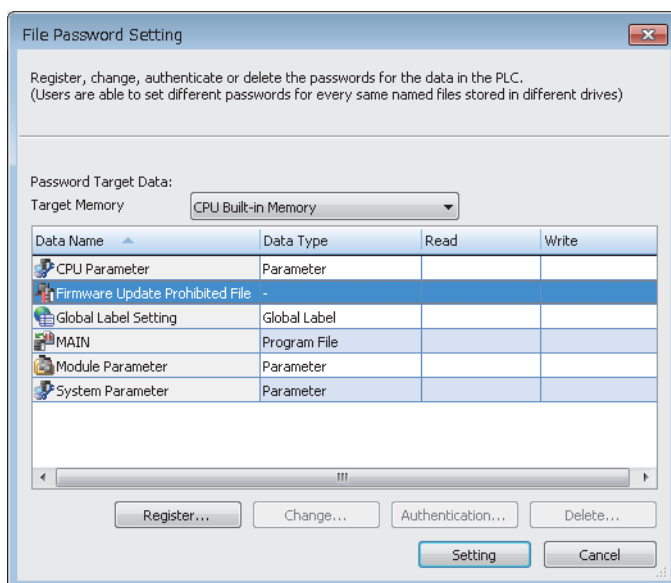

For the setting method of file password, refer to the following.

☞ GX Works3 Operating Manual

3. Power off and on or reset the CPU module.

Clearing the setting for firmware update prohibition

This section describes how to remove the prohibition on the firmware update.

To execute the firmware update, clear the setting for firmware update prohibition using an engineering tool.

1. Delete the file password set to the firmware update prohibition file.

 [Project] ⇒ [Security] ⇒ [File Password Setting]

2. Delete the firmware update prohibition file from the "\$MELPRJ\$" folder in the data memory of the CPU module.

 [Online] ⇒ [User Data] ⇒ [Delete]

For details on the operation method, refer to the following.

 GX Works3 Operating Manual

Precautions

Point

For the precautions of the modules used, refer to the User's Manual for each module.

■ Precautions on firmware update files

- Check the target model and obtain the firmware update file that matches with the target model from your local Mitsubishi representative. The firmware update is not executed if the firmware update file does not match with the target model.
- Do not modify the firmware update file (file name and data) obtained from your local Mitsubishi representative.
- When multiple firmware update files are obtained for one module, do not modify the combination of file versions. Execute the firmware update of the update files simultaneously.

■ Precautions for executing the firmware update

- Before starting the firmware update, check that the module to be updated has started up normally.
- Check the following before executing the firmware update: The programmable controller has stopped; the system to be updated has stopped; and the communication cables and wires of the other systems, which are connected with the system to be updated via networks, has been disconnected.
- Starting the firmware update during the file operations may result in corruption of the file. Before starting the firmware update, check that all file operations are finished.
- Check that the file operations (such as the write to programmable controller, online change, and file transfer function) are not executed on the modules to be updated and those not to be updated. Starting the firmware update during file operations may result in corruption of the file.
- When executing the firmware update for multiple modules, it takes some time until update completion. The firmware update for one module takes approximately four minutes.
- If the CPU module is powered off while the firmware update is being executed, the CPU module may fail. In this case, the CPU module can be recovered by executing the firmware update using an SD memory card.
- Do not execute the other functions while the firmware update is being executed.
- Check the system operation before and after the firmware update. If an error occurs in the system after the firmware update, return the version to the previous one. When returning the version to the previous one, please consult your local Mitsubishi representative.
- When the firmware update is performed with the checkbox of "Automatically Reset After Completing Update" unchecked, reset the CPU module manually after the firmware update is completed. To use the remote RESET function, set "Remote Reset Setting" to "Enable" in the "CPU Parameter" in advance. When "Remote Reset Setting" is set to "Disable", visiting the site where the programmable controller is installed is necessary for resetting the CPU module.
- The update writing CPU module stores the event occurrence time by the internal time of CPU module. The time is displayed on "Output Log" of the "Update Firmware" window by the time of personal computer. The time of "Event History" matches the time of "Output Log" by synchronizing the internal time of CPU module with the time on the personal computer.
- When the following operations are executed during the firmware update, the firmware update may be completed with an error, resulting in failure of the module. In addition, the module may not start up or the firmware update may not restart.

Execute the firmware update using an engineering tool carefully.

- Turning off or resetting the CPU modules
 - Changing the operating status using the remote operation from the engineering tool or the switch of the CPU module
 - Operating from an external device
 - Connecting/disconnecting the connection cable between the update writing CPU module and engineering tool
 - Connecting/disconnecting the module to be updated
 - Starting the firmware update from the engineering tool
 - Finishing the engineering tool
- Do not insert/remove the SD memory card during the firmware update. Doing so may destroy the SD memory card data. The SD CARD OFF button is not available during the firmware update. Do not press the button to remove the SD memory card.
 - The module during the online module change cannot be selected on the "Firmware Update" window in the engineering tool. After the firmware update is executed to even one module, the online module change is not started/continued to all modules.

■Precautions of when the firmware update is being executed in a multiple CPU system

- Do not execute the firmware update during the remote operation from the other engineering tool and the remote operation during the firmware update to the CPU module of No.2 or later in a multiple CPU system. If the state of CPU module is changed to the RUN state during the firmware update, the data will not be written, resulting in failure of the module.
- When the firmware version of the targeted module does not support this method (the update using an engineering tool), update it to the version that supports this method using an SD memory card first. Then, execute the update. If the firmware update is executed to the CPU module from the engineering tool, the operation is not guaranteed.
- Check that the file operations including the write to programmable controller, online change, and file transfer function are not executed on the CPU module of No.2 or later, which are not to be updated. Starting the firmware update during file operations may result in corruption of the file.

■Precautions of when the firmware update is completed

After the firmware update is completed, power off and on or reset the update writing CPU module. To execute the remote RESET function, use the remote operation function of the engineering tool. If the other function is executed without the CPU module being reset or powered off and on, the operation of all modules and the display on the engineering tool are not guaranteed.

■Precautions of when the firmware update is suspended

During the firmware update, when the engineering tool is finished, when the personal computer running the engineering tool is shut down, or when a communication error occurs, the update is suspended. The reset using the automatic reset setting in the engineering tool is not executed. Check that the data is not being writing using the LED, and reset the CPU module manually.

■Precautions of when the firmware version is changed to the previous version

Using an engineering tool, the firmware version of the CPU module can be changed to the previous version that is not available for the firmware update using an engineering tool. When updating the firmware version again, update the version using an SD memory card.

■Precautions for redundant system configuration

- When the firmware update is executed to the control system, the system control of the updated module stops. Before executing the firmware update, check the following: The system to be updated has stopped; and the communication cables and wires of other systems, which are connected to the system to be updated via networks, has been disconnected.
- Before executing the firmware update without stopping the system control, unplug the tracking cable. If the firmware update is executed with the tracking cable connected, the operation is not guaranteed.
- When executing the firmware update without stopping the system control, if an error occurs in the control system before the update is completed in the standby system, the system control stops.
- The firmware update is not executed to the system that the firmware update prohibition is set to. When the firmware update should not be executed to both systems, set the firmware update prohibition to both systems.
- Do not switch the system during the firmware update. Doing so can cause the system to stop or the firmware update to fail.
- In a redundant system with redundant extension base unit, do not execute the firmware update of modules in the control system while the standby system is operating. If executed, update may fail.
- When updating modules on extension base units, connect the computer directly to the CPU module of the control system. If updated connecting the computer to the CPU module of the standby system, update fails.

Update using an SD memory card

The firmware versions of the CPU module and intelligent function module are updated using an SD memory card. The firmware version of a module is updated just using an SD memory card. Dedicated software is not required.



Firmware update file

Target models

The following table lists the target models.

■CPU module

Module	Model	Applicable module firmware version
Programmable controller CPU ^{*1*2}	R01CPU, R02CPU	"01" or later
	R04CPU, R08CPU, R16CPU, R32CPU, R120CPU	"23" or later
	R04ENCPU, R08ENCPU, R16ENCPU, R32ENCPU, R120ENCPU	CPU part: "38" or later Network part: "32" or later
Process CPU	R08PCPU, R16PCPU, R32PCPU, R120PCPU	"14" or later
C Controller module	R12CCPU-V	"09" or later

*1 For the RnENCPU, firmware versions of the CPU part and network part are updated.

*2 For precautions specific to each module, refer to the User's Manual (Application) for the module used.

■Intelligent function module

Module	Model	Applicable module firmware version	Applicable engineering tool version
C intelligent function module	RD55UP06-V	"07" or later	1.050C or later
	RD55UP12-V	"01" or later	1.065T or later
MES interface module	RD81MES96N	"01" or later	1.060N or later
High speed data logger module	RD81DL96	"08" or later	1.065T or later
OPC UA server module	RD81OPC96	"04" or later	1.065T or later
Recorder module	RD81RC96	"01" or later	1.065T or later
Camera recorder module	RD81RC96-CA	"01" or later	1.072A or later
High speed data communication module	RD81DC96	"01" or later	1.075D or later

Update procedure

■ Preparation

1. From your local Mitsubishi representative, obtain the firmware update information for the model to which the update will be executed. The following figures show folder structures of the firmware update information. mmmm of the firmware update file represents a model name and vv of the firmware update file represents a firmware version.

- For the RnCPU and Process CPU

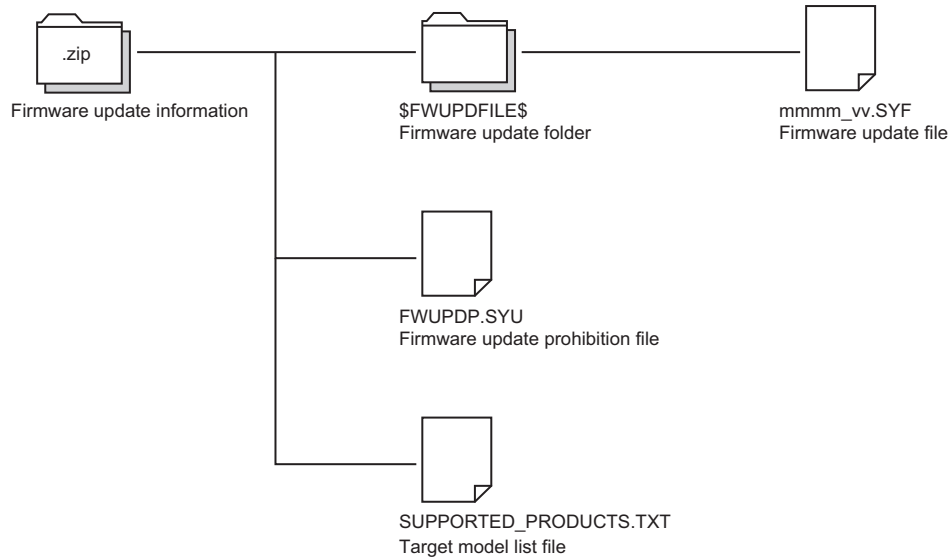

- For the RnENCPU

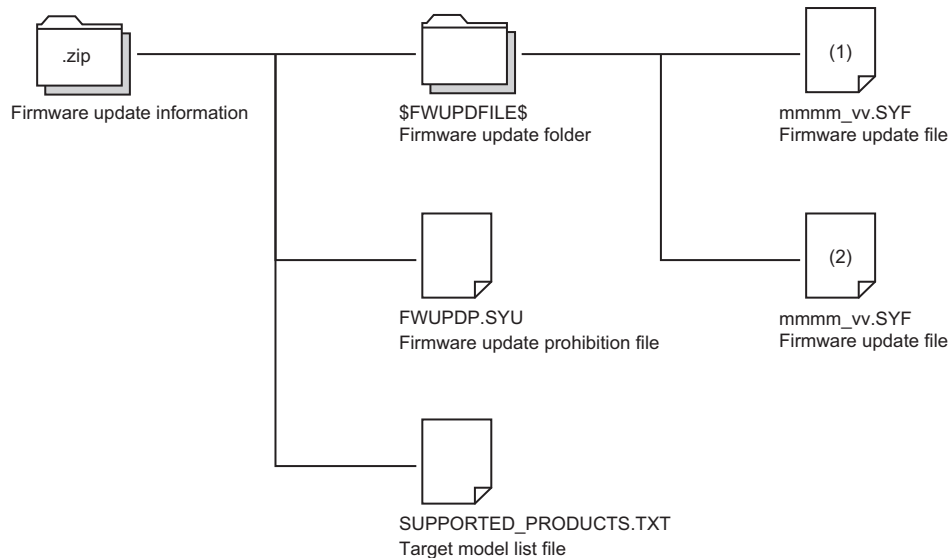

- (1) For the CPU part
- (2) For the network part

- For the C Controller module or intelligent function module

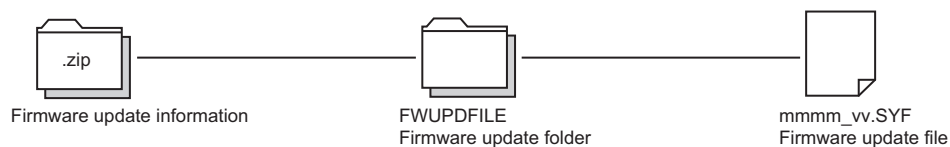

Point

For the C Controller module or intelligent function module, a firmware update prohibition file and a target model list file are not stored in a ZIP file. In addition, the name of the "\$FWUPDFILE\$" folder will be "FWUPDFILE".

- Unzip the firmware update information (ZIP file).
- Use a personal computer to save the "\$FWUPDFILE\$" folder in the root directory of an SD memory card. If the "\$FWUPDFILE\$" folder already exists in the SD memory card, delete the "\$FWUPDFILE\$" folder before saving the folder.

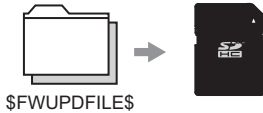

- Mount the module on the base unit.
 - For the CPU moduleMount the CPU module on the CPU slot.

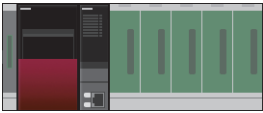
**Point**

For the Process CPU (redundant mode), the firmware can be updated without interrupting the redundant system. For the procedure (operation), refer to the following.

☞ Page 232 Operation (firmware update of the Process CPU (redundant mode) without interrupting the redundant system)

Restriction

When using the RnENCPU, configure a single CPU system. If a multiple CPU system is configured, the firmware is not updated.

- For the intelligent function module
- Mount the CPU module on the CPU slot, and mount the intelligent function module on a slot located after the CPU slot.



- Clear the setting for firmware update prohibition if it has been set. (☞ Page 239 Clearing the setting for firmware update prohibition)

Restriction

Use a personal computer to save the "\$FWUPDFILE\$" folder in an SD memory card. The "\$FWUPDFILE\$" folder cannot be saved in an SD memory card using an engineering tool.

- Before updating the firmware version, back up the data such as programs and parameters.

■ Operation (programmable controller CPU and Process CPU)

1. Power off the CPU module and insert the SD memory card to it.
2. Press and hold the SD CARD OFF button (1) and power on the CPU module, and subsequently the firmware update is executed.*1*2*3*4

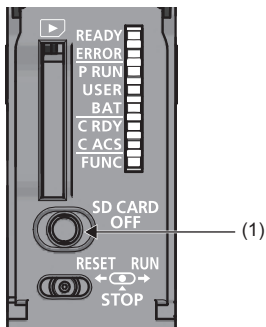

While the firmware update is being executed, READY LED turns on in red and PROGRAM RUN LED turns on in green.

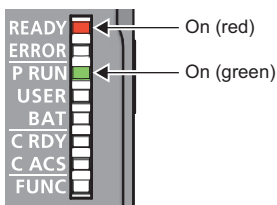

- *1 Resetting the CPU module while pressing the SD CARD OFF button also executes the firmware update.
 - *2 Note, for the programmable controller CPU (excluding the R01CPU, R02CPU, and RnENCPU) with firmware version earlier than "28", just powering on or resetting the CPU module will execute the firmware update, even without pressing the SD CARD OFF button.
 - *3 Do not update the firmware version of the Process CPU while the automatic restoration with the SD CARD OFF button is being executed. If the both functions are executed simultaneously, the automatic restoration with the SD CARD OFF button does not work.
 - *4 In the Process CPU, the 300CH error is detected if a firmware update file is not stored in the SD memory card.
3. When the firmware update is completed successfully, the PROGRAM RUN LED flashes in green. If the firmware update failed, the ERROR LED*1 flashes in red. Take necessary actions for the failure. (☞ Page 242 Troubleshooting)

Normally finished	Failed
<p>The diagram shows the LED indicators for a successful update. The 'READY' LED is on (red) and the 'P RUN' LED is flashing (green). Arrows point to these LEDs with labels: 'On (red)' for READY and 'Flashing (green)' for P RUN.</p>	<p>The diagram shows the LED indicators for a failed update. The 'READY' LED is either on (red) or off, and the 'ERROR' LED is flashing (red). Arrows point to these LEDs with labels: 'On (red) or off' for READY and 'Flashing (red)' for ERROR.</p>

*1 For the RnENCPU, the LED of the CPU part flashes.

Point

During execution of the firmware update, the CPU module cannot communicate with other modules, and an engineering tool or external devices cannot communicate with the CPU module.

4. Once the firmware update is complete, power off the CPU module and remove the SD memory card.*1 After that, power on or reset the CPU module.
- *1 To retry the firmware update, leave the SD memory card in the CPU module, press and hold the SD CARD OFF button, and power off and on or reset the CPU module.
5. The backed up programs and parameters are restored.
 6. Check the system operation.

■Operation (firmware update of the Process CPU (redundant mode) without interrupting the redundant system)

1. Remove the tracking cable from the redundant function module of the standby system.
2. Power off the CPU module of the standby system and insert an SD memory card to the CPU module.
3. Press and hold the SD CARD OFF button (1) and power on the CPU module, and subsequently the firmware update is executed.*1*2*3

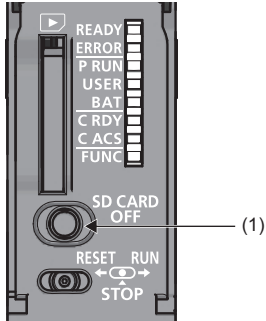

While the firmware update is being executed, READY LED turns on in red and PROGRAM RUN LED turns on in green.

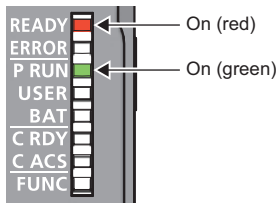

*1 Resetting the CPU module while pressing the SD CARD OFF button also executes the firmware update.

*2 Do not update the firmware version while the automatic restoration with the SD CARD OFF button is being executed. If the both functions are executed simultaneously, the automatic restoration with the SD CARD OFF button does not work.

*3 The 300CH error is detected if a firmware update file is not stored in the SD memory card.

4. When the firmware update is completed successfully, the PROGRAM RUN LED flashes in green. If the firmware update failed, the ERROR LED flashes in red. Take necessary actions for the failure. (☞ Page 242 Troubleshooting)

Normally finished	Failed
<p>READY (red) On (red) P RUN (flashing green) Flashing (green)</p>	<p>READY (red) On (red) or off ERROR (flashing red) Flashing (red)</p>

Point

During execution of the firmware update, the CPU module cannot communicate with other modules, and an engineering tool or external devices cannot communicate with the CPU module.

5. Remove the SD memory card and power off the standby system. Then, connect a tracking cable to the redundant function module of the standby system. After connecting a tracking cable, power on the standby system.*1

*1 To retry the firmware update, leave the SD memory card in the CPU module, press and hold the SD CARD OFF button, and power on the standby system.

6. To ensure that the systems are ready for the system switching, check the status of the following:

- BACKUP LED: On*¹
- SM1646 (System switching by a user): On

*¹ When a network module is used, returning disconnected stations to the system may take some time after the standby system is powered on or reset.

When the systems are ready for the system switching, switch the systems using the engineering tool. For the system switching using the engineering tool, refer to the following.

 MELSEC iQ-R CPU Module User's Manual (Application)

7. Remove the tracking cable from the redundant function module of the new standby system.

8. Take the same steps from Step 2 to 4 for the CPU module of the new standby system to update the firmware version.

9. Remove the SD memory card and power off the new standby system. Then, connect a tracking cable to the redundant function module of the new standby system. After connecting a tracking cable, power on the new standby system.*¹

*¹ To retry the firmware update, leave the SD memory card in the CPU module, press and hold the SD CARD OFF button, and power on the new standby system.

10. To change the system setting (control/standby) to the same state before the firmware update, switch the systems using the engineering tool. Before switching the systems, take the step 5 to ensure that the systems are ready for the system switching.

■Operation (C Controller module)

1. Power off the C Controller module and insert the SD memory card to it.
2. Set the MODE/SELECT switch (1) on the MODE position.

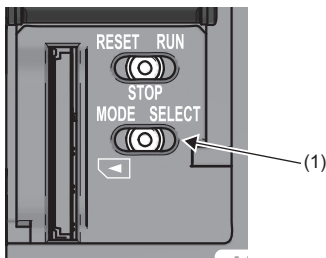

3. Power on the C Controller module with the MODE/SELECT switch set to the MODE position.
 - Normal: The BUS RUN LED turns on in green, and "M-00" is displayed on the dot matrix LED.



- Error: The ERROR LED flashes in red, and an error code is displayed on the dot matrix LED. (☞ Page 242 Troubleshooting)

4. Release the MODE/SELECT switch and put it back to the center position.
5. Set the MODE/SELECT switch (2) to the SELECT position. Every time the switch is set to the SELECT position, the value of mode displayed on the dot matrix LED is changed. Repeat this switch movement until "0020" is displayed on the dot matrix LED.

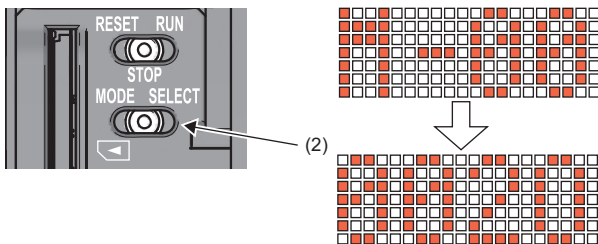

6. Set the RESET/STOP/RUN switch (3) to the RUN position.

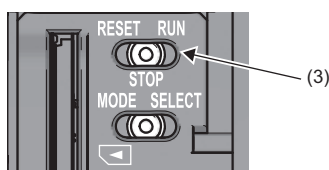

7. The BUS RUN LED flashes in green.



8. Check that the BUS RUN LED turns on in green and "0000" is displayed on the dot matrix LED, then power off and on or reset the C Controller module.

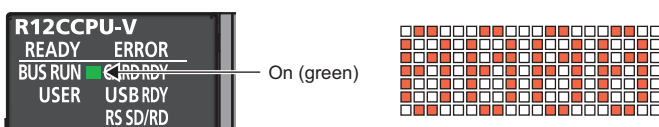

9. The firmware update is executed. While the firmware update is being executed, READY LED turns on in red and BUS RUN LED turns on in green.

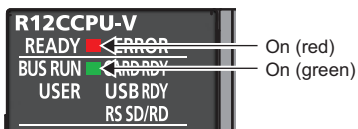

10. When the firmware update is completed successfully, the BUS RUN LED flashes in green. If the firmware update failed, the READY LED turns off, turns on, or flashes in red, and the ERROR LED flashes in red. Take necessary actions for the failure. (☞ Page 242 Troubleshooting)

■ Normally finished



■ Failed

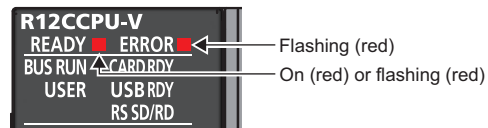
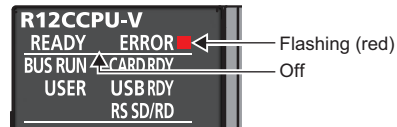

Point 🔍

During execution of the firmware update, the C Controller module cannot communicate with other modules, and an engineering tool or external devices cannot communicate with the C Controller module.

■Operation (intelligent function module)

1. Power off the target module, and insert the SD memory card to it.
2. Set "Mode Settings" of the target module to "Firmware update" in the engineering tool.
 [Navigation window] ⇒ [Parameter] ⇒ [Module Information] ⇒ [(the target module)] ⇒ [Basic Setting] ⇒ [Various Operations Settings] ⇒ [Mode Settings]
3. Check that the operating status of the CPU module is the STOP state, and write parameters.
4. Reset the CPU module.

After the CPU module is reset, the firmware update is executed.

While the update is being executed, the RUN LED on the target module flashes in red.

Ex.

(Example) C intelligent function module



5. Once the firmware update is completed successfully, the RUN LED on the target module turns on in red. If the firmware update failed, the RUN LED turns off, turns on in red, or flashes in red, and the ERR LED flashes in red. Take necessary actions for the failure. (☞ Page 242 Troubleshooting)

Ex.

(Example) C intelligent function module

■Normally finished



■Failed

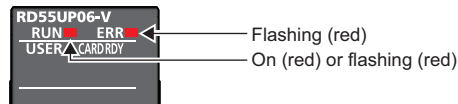
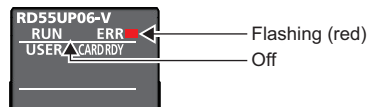

6. Change "Mode Settings" of the target module to "Online" in the engineering tool.
 [Navigation window] ⇒ [Parameter] ⇒ [Module Information] ⇒ [(the target module)] ⇒ [Basic Setting] ⇒ [Various Operations Settings] ⇒ [Mode Settings]
7. Write parameters to the CPU module.
8. Reset the CPU module.

Point

During the execution of the firmware update, the engineering tool or external devices cannot communicate with the intelligent function module.

■Checking the version after the firmware update (for the CPU module)

1. Power off and on the CPU module and check that the firmware version is updated. Although an error may occur at power-on, the error can be cleared by following the procedure of step 2 and later. (☞ Page 240 Result of the firmware update)

Point

For the programmable controller CPU (excluding the R01CPU, R02CPU, and RnENCPU) with a firmware version earlier than "28", remove an SD memory card before powering on the CPU module. If not, the firmware update will be executed again.

2. Initialize the CPU module where the firmware is updated.

☞ [Online] ⇄ [CPU Memory Operation]

3. Write the data, which are backed up before the firmware update, to the CPU module. Then, power off and on the CPU module.

■Checking the version after the firmware update (for the intelligent function module)

1. Power off the CPU module.
2. Remove the SD memory card from the intelligent function module.
3. Power on the CPU module, and check that the firmware version is updated. (☞ Page 240 Result of the firmware update)

Setting for firmware update prohibition

This section describes how to prohibit the firmware update.

■Programmable controller CPU and Process CPU

To prohibit the firmware update, write a firmware update prohibition file to the CPU module and set a file password.

1. Using an engineering tool, write the firmware update prohibition file (FWUPDP.SYU) to the "\$MELPRJ\$" folder in the data memory of the CPU module. The firmware update prohibition file (FWUPDP.SYU) is included in the firmware update information obtained for the preparation. (👉 Page 229 Preparation)

👉 [Online] ⇒ [User Data] ⇒ [Write]

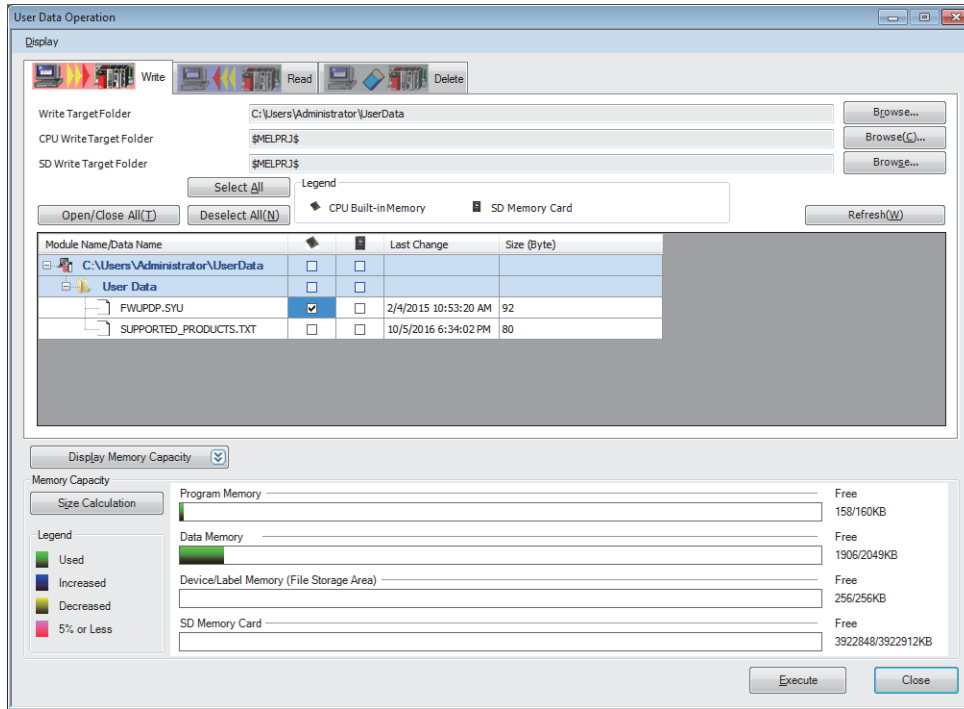

2. Using the engineering tool, set a file password to the firmware update prohibition file.

👉 [Project] ⇒ [Security] ⇒ [File Password Setting]

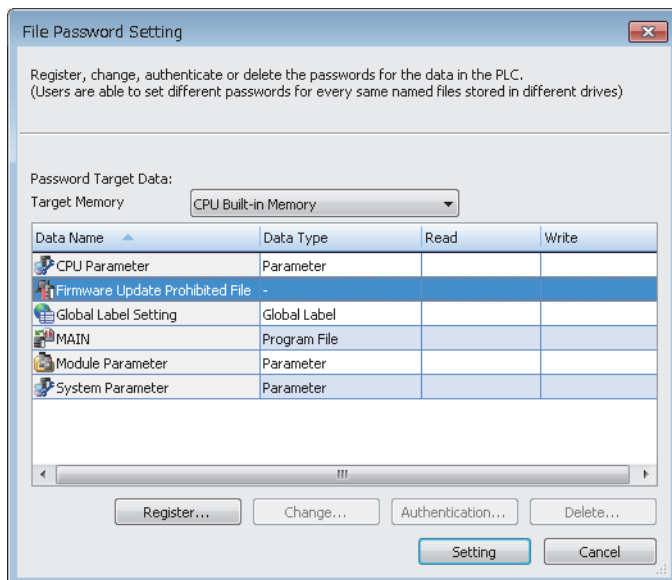

For the setting method of file password, refer to the following.

📖 GX Works3 Operating Manual

■C Controller module

To prohibit the firmware update, set a file password by using the C Controller module dedicated function (CCPU_LockFWUpdate).

For details on the C Controller module dedicated function, refer to the following.

 MELSEC iQ-R C Controller Module Programming Manual

■MES interface module

To prohibit the firmware update, set a password on the "Manage MES Interface Module" window of MES Interface Function Configuration Tool.

For details on the "Manage MES Interface Module" window, refer to the following.

 MELSEC iQ-R MES Interface Module User's Manual (Application)

■High speed data logger module

To prohibit the firmware update, set a password on the "Manage" window of High Speed Data Logger Module Configuration Tool.

For details on the "Manage" window, refer to the following.

 MELSEC iQ-R High Speed Data Logger Module User's Manual (Application)

■OPC UA server module

To prohibit the firmware update, set a password on the "OPC UA Server Module Manage" window of OPC UA Server Module Configuration Tool.

For details on the "OPC UA Server Module Manage" window, refer to the following.

 MELSEC iQ-R OPC UA Server Module User's Manual (Application)

■High speed data communication module

To prohibit the firmware update, set a password on the "Manage" window of High Speed Data Communication Module Configuration Tool.

For details on the "Manage" window, refer to the following.

 MELSEC iQ-R High Speed Data Communication Module User's Manual (Application)

Clearing the setting for firmware update prohibition

This section describes how to remove the prohibition on the firmware update.

■Programmable controller CPU and Process CPU

To execute the firmware update, clear the setting for firmware update prohibition using an engineering tool.

1. Delete the file password set to the firmware update prohibition file.

 [Project] ⇒ [Security] ⇒ [File Password Setting]

2. Delete the firmware update prohibition file from the "\$MELPRJ\$" folder in the data memory of the CPU module.

 [Online] ⇒ [User Data] ⇒ [Delete]

For details on the operation method, refer to the following.

 GX Works3 Operating Manual

■C Controller module

By applying the C Controller module dedicated function (CCPU_UnLockFWUpdate), the prohibition on the firmware update function can be removed.

For details on the C Controller module dedicated function, refer to the following.

 MELSEC iQ-R C Controller Module Programming Manual

■MES interface module

The prohibition of the firmware update can be removed on the "Manage MES Interface Module" window of MES Interface Function Configuration Tool.

For details on the "Manage MES Interface Module" window, refer to the following.

 MELSEC iQ-R MES Interface Module User's Manual (Application)

■High speed data logger module

The prohibition of the firmware update can be removed on the "Manage" window of High Speed Data Logger Module Configuration Tool.

For details on the "Manage" window, refer to the following.

 MELSEC iQ-R High Speed Data Logger Module User's Manual (Application)

■OPC UA server module

The prohibition of the firmware update can be removed on the "OPC UA Server Module Manage" window of OPC UA Server Module Configuration Tool.

For details on the "OPC UA Server Module Manage" window, refer to the following.

 MELSEC iQ-R OPC UA Server Module User's Manual (Application)

■High speed data communication module

The prohibition of the firmware update can be removed on the "Manage" window of High Speed Data Communication Module Configuration Tool.

For details on the "Manage" window, refer to the following.

 MELSEC iQ-R High Speed Data Communication Module User's Manual (Application)

Result of the firmware update

The result of the firmware update can be checked by the following method.

■Special relay, special register (CPU module)

Check if the firmware update is normally finished or failed. If the firmware update failed, an error code will be stored in SD922.

( MELSEC iQ-R CPU Module User's Manual (Application),  MELSEC iQ-R C Controller Module User's Manual)

- SM922 (Firmware update completion with/without an error)
- SD904, SD905 (Latest firmware update information (Network))
- SD912 to SD920 (Latest firmware update information (CPU))*¹
- SD921, SD922 (Latest firmware update result)



*¹ For the RnENCPU, information on the CPU part is displayed.

■Buffer memory (intelligent function module)

Check if the firmware update is normally finished or failed. ( Manuals for each intelligent function module used)

- Firmware update completion with/without an error
- Latest firmware update result

■Event history function

Refer to event codes to check if the firmware update succeeded or failed. ( MELSEC iQ-R CPU Module User's Manual (Application),  MELSEC iQ-R C Controller Module User's Manual,  Manuals for each intelligent function module used)

History of the firmware update

The history of the firmware update can be checked by the following method.

■Special register (CPU module)

Time when the firmware update was executed, versions before and after the update, and the result of the previous update can be checked. (📖 MELSEC iQ-R CPU Module User's Manual (Application), 📖 MELSEC iQ-R C Controller Module User's Manual)

- SD906, SD907 (Previous firmware update information (Network))
- SD923 to SD931 (Previous firmware update information (CPU))*¹
- SD932, SD933 (Previous firmware update result)

*¹ For the RnENCPU, information on the CPU part is displayed.

■Buffer memory (intelligent function module)

Time when the firmware update was executed, versions before and after the update, and the result of the previous update can be checked. (📖 Manuals for each intelligent function module used)

- Previous firmware update information
- Previous firmware update result

Precautions



For the precautions, refer to the User's Manual (Application) for the module used.

■Precautions for firmware update files

- Check the target model and obtain the firmware update file that matches with the target model from your local Mitsubishi representative. The firmware update is not executed if the firmware update file does not match with the target model.
- Do not modify the firmware update file (file name and data) obtained from your local Mitsubishi representative.
- When multiple firmware update files are obtained for one module, do not modify the combination of file versions. Execute the firmware update using all the update files at the same time.

■Precautions of when the firmware update is being executed

- Do not power off or reset the CPU module during execution of the firmware update. If the firmware update is suspended, it automatically restarts by powering off and on or resetting the CPU module.
- Do not remove the SD memory card from the CPU module during execution of the firmware update. If removed before the update is completed, the update may fail.
- Do not execute the online module change during execution of the firmware update.

■Precautions on the backup data writing

The free space in the program memory may be insufficient when data backed up is written to the CPU module. In this case, perform any of the following operations and write the data again.

- Reduce the setting value of "Allocate Memory for Online Program Change".
- Reduce the number of steps in programs.

Troubleshooting

■CPU module

If the firmware update failed, check the error codes that are stored in SD922 and SD933. After powering off and on or resetting the CPU module, take appropriate actions.

Point

When using a C Controller module, read "PROGRAM RUN" as "BUS RUN" in the column of "LED status" in the following table.

Error code	Error name	Error definition and cause	LED status			Action
			READY	PROGRAM RUN	ERROR	
0100H	Flash ROM error	<ul style="list-style-type: none"> Failed to access the flash ROM of the CPU module. 	Off	Off	Flashing	<ul style="list-style-type: none"> Execute the firmware update function again.
0200H	Model mismatched	<ul style="list-style-type: none"> The firmware update file that does not match with the target CPU module was used. 	On	Off	Flashing	<ul style="list-style-type: none"> Check the target CPU module and execute the firmware update function again.
0201H	File invalid	<ul style="list-style-type: none"> The invalid firmware update file was used. 				<ul style="list-style-type: none"> Write the firmware update file to the SD memory card again. Do not change the file name of the firmware update file.
0202H	Combination error	<ul style="list-style-type: none"> An incompatible version of the firmware update file has been used. 				<ul style="list-style-type: none"> When updating a firmware version, use a firmware update file that is supported by the firmware version to be updated.
0203H	Firmware update prohibited state	<ul style="list-style-type: none"> The firmware update was prohibited by the setting for firmware update prohibition. 				<ul style="list-style-type: none"> Confirm that the firmware update is not prohibited and can be executed.
0300H	Firmware data error	<ul style="list-style-type: none"> A firmware data error was detected during execution of the firmware update function. 	Flashing	Off	Flashing	<ul style="list-style-type: none"> Execute the firmware update function again.

If the firmware update fails even after the items above are checked and the actions are taken, the possible cause is a hardware failure. Please consult your local Mitsubishi representative.

- C Controller module

The ERROR LED flashes, and a value corresponding to the error is displayed on the dot matrix LED.

Dot matrix LED	Error name	Error definition and cause	Action
E101	Firmware update function execution error	The firmware update failed.	Perform the firmware update function again.
E102		The power was turned off or the C Controller module was reset while executing the firmware update.	Turn the power off and on or reset the C Controller module to start the firmware update function again.

If the firmware update fails even after the items above are checked and the actions are taken, the possible cause is a hardware failure. Please consult your local Mitsubishi representative.

■ Intelligent function module

If the firmware update failed, an error code is stored in "Latest firmware update result" and "Previous firmware update result". Check the error code and take appropriate actions after powering off and on or resetting the CPU module.

To check error codes, before powering off and on or resetting the CPU module, set "Mode Settings" of the intelligent function module to "Online" in the engineering tool.

 [Navigation window] ⇒ [Parameter] ⇒ [Module Information] ⇒ (the module used) ⇒ [Basic Setting] ⇒ [Various Operations Settings] ⇒ [Mode Settings]

Point

When executing the firmware update again, check that measures to reduce noise of the system have adequately been taken.

Error code	Error name	Error definition and cause	LED status		Action
			RUN	ERR	
0100H	Flash ROM error	<ul style="list-style-type: none"> Accessing the flash ROM of the intelligent function module failed. 	Off	Flashing	<ul style="list-style-type: none"> Execute the firmware update function again.
0200H	Model mismatched	<ul style="list-style-type: none"> The firmware update file not for the target intelligent function module was used. 	On	Flashing	<ul style="list-style-type: none"> Check the target intelligent function module, and execute the firmware update function again.
0201H	File invalid	<ul style="list-style-type: none"> The invalid firmware update file was used. 			<ul style="list-style-type: none"> Write the firmware update file to the SD memory card again. Do not change the file name of the firmware update file.
0203H	Firmware update prohibited state	<ul style="list-style-type: none"> The firmware update was prohibited by the setting for firmware update prohibition. 			<ul style="list-style-type: none"> Confirm that the firmware update is not prohibited and can be executed.
0300H	Firmware data error	<ul style="list-style-type: none"> A firmware data error was detected during execution of the firmware update function. 	Flashing	Flashing	<ul style="list-style-type: none"> Execute the firmware update function again. If the firmware update failed again, the firmware update file may be broken. Obtain the file again.

If the firmware update fails even after the items above are checked and the actions are taken, the possible cause is a hardware failure. Please consult your local Mitsubishi representative.

A

Appendix 3 Pair Version

Pair version is version information to determine modules used as a pair. In each of the following combinations, use the modules of the same version.

- SIL2 Process CPU and SIL2 function module
- Safety CPU and safety function module

Checking methods

This section describes how to check the pair version of modules.

Checking on the module

The pair version is printed on the rating plate of the module. The rating plate is located on the side of the module. (👉 Page 210 Checking on the module)

Checking with the special register or buffer memory

The pair version can be checked with the special register or buffer memory.

Module	Area
SIL2 Process CPU	Special register: SD206
Safety CPU	Special register: SD206
SIL2 function module, safety function module	Buffer memory: UnIG60

Checking with the engineering tool

The pair version can be checked on the [Module Information List] tab opened from the "Module Diagnostics" window.

👉 [Diagnostics] ⇒ [Module Diagnostics] ⇒ [Module Information List]

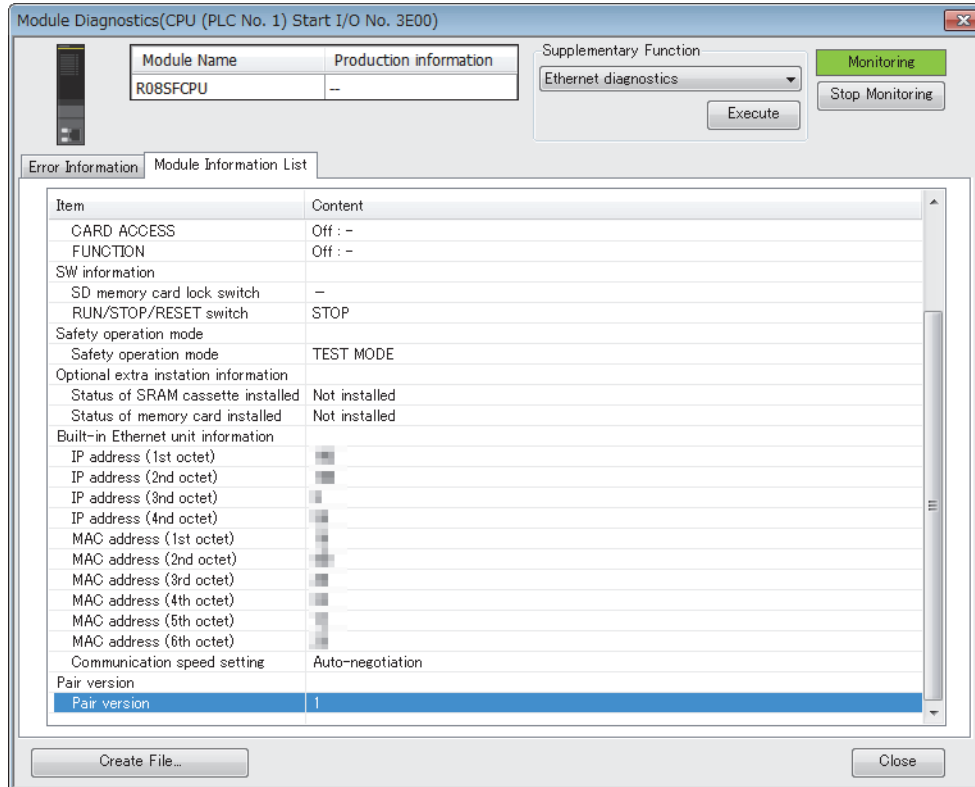

Appendix 4 Troubleshooting by Symptom

This section describes troubleshooting of power supply modules and base units.

When the POWER LED of the power supply module turns off, or the ERR contact turns off (opens)

Check the following:

Check item	Action
The power supply module is not mounted on the base unit properly.	Remove the power supply module from the base unit, and mount it back on the base unit. Then, restore power to the system.
Is the READY LED of the CPU module on?	If the READY LED is not on, an error has occurred in the power supply module. Replace the power supply module.
Is the power supply voltage appropriate?	Supply power voltage within the specified range. (☞ Page 137 Performance Specifications of Power Supply Module)
Has the internal current consumption within the entire system exceeded the rated output current of the power supply module?	If the consumption has exceeded the rated output current, review the system configuration so that the internal current consumption does not exceed the rated output current. (☞ Page 98 Consideration for internal current consumption)
Does the POWER LED turn on when power is restored to the system after all modules, except the power supply module, have been removed?	If the POWER LED does not turn on, an error has occurred in a module other than the power supply module. Repeatedly supply power to the system, returning the modules back to the system one by one. The last module mounted immediately before the POWER LED turned off has been failed. Replace the module.

If the POWER LED of the power supply module does not turn on even after the items above are checked and the actions are taken, the possible cause is a hardware failure of the power supply module. Please consult your local Mitsubishi representative.

When the specific extension base unit cannot be recognized

Check the following:

Check item	Action
The extension base unit that cannot be recognized is the Q series extension base unit.	Refer to the troubleshooting for the case where the specific Q series extension base unit cannot be recognized. (☞ Page 246 When the specific Q series extension base unit cannot be recognized)
The POWER LED of the power supply module of the extension base unit that cannot be recognized is turned off.	Refer to the troubleshooting for the power supply module. (☞ Page 245 When the POWER LED of the power supply module turns off, or the ERR contact turns off (opens))
The extension cable is not correctly connected.	Correctly connect the extension cable.
The specific extension base unit cannot be recognized even after the above items were checked.	Take actions in the following order. <ul style="list-style-type: none">• Replace the extension cable.• Replace the extension base unit.• Replace the base unit on the upper level of the extension base unit.

If the specific extension base unit cannot be recognized even after the items above are checked and the actions are taken, the possible cause is a hardware failure. Please consult your local Mitsubishi representative.

A

When the specific Q series extension base unit cannot be recognized

Check the following:

Check item	Action
The POWER LED of the power supply module on the Q series extension base unit that cannot be recognized is off.	Refer to the troubleshooting for the power supply modules. (☞ User's Manual (Hardware Design, Maintenance and Inspection) for the Q series CPU module used)
The connector pin is not correctly inserted in the extension level setting connector.	Correctly insert the connector pin in the extension level setting connector.
The extension cable is not correctly connected.	Correctly connect the extension cable.
The specific Q series extension base unit cannot be recognized even after the above items were checked.	Take actions in the following order. <ul style="list-style-type: none"> • Replace the extension cable. • Replace the Q series extension base unit. • Replace the base unit on the upper level of the Q series extension base unit.

If the specific Q series extension base unit cannot be recognized even after the items above are checked and the actions are taken, the possible cause is a hardware failure. Please consult your local Mitsubishi representative.

When an error occurs in a redundant extension base unit

When a CONNECT LED turns off

Check the following:

Check item	Action
The extension cable is not connected properly.	Check the connection status of the extension cable using the system monitor. If the cable is not properly connected, connect it again.
There are problems on the extension cable.	<ul style="list-style-type: none"> • Check that the overall cable distance of the extension cables is within the range of the specifications. • Replace the extension cable because it may be faulty or there may be a break in it.

If the CONNECT LED does not turn on even after the items above are checked and the actions are taken, the possible cause is a failure of the extension base unit. Please consult your local Mitsubishi representative.

When a tracking communication error occurs at start-up of the system

Check the following:

Check item	Action
Before the both systems start up, either system was powered off and on.	Restart the system where the CPU module in which a stop error occurs is mounted.*1
Before the system that was powered on first starts up, another system was powered on.	
It took much time to start up the standby system. (For example, it took longer time to perform the automatic restoration or boot operation than usual, or the SD memory card diagnostics was performed.)	

*1 If an error occurs in the standby system, using the automatic standby system recovery function can recover the standby system without manual operations. (☞ MELSEC iQ-R CPU Module User's Manual (Application))

When a system bus error occurs at start-up of the system

Check the following:

Check item	Action
The firmware version of the CPU module used does not support the use of the redundant extension base unit.	Update the firmware version of the CPU module to the version that supports the use of the redundant extension base unit. (☞ MELSEC iQ-R CPU Module User's Manual (Application))

Appendix 5 Differences Between MELSEC iQ-R Series and MELSEC-Q Series

For the differences between MELSEC iQ-R series and MELSEC-Q series, refer to the following.

 MELSEC-Q Series to MELSEC iQ-R Series Migration Guide (L08510ENG)

Appendix 6 How to Use MELSEC-Q Series Modules

This section describes how to use MELSEC-Q series modules.

- For the MELSEC-Q series modules which can be used, refer to the following.

☞ Page 83 MELSEC-Q series

- For precautions when using each module, refer to the following.

☞ Page 256 Precautions

- When using module dedicated instructions, create programs by referring to the manual for each module.
- When using the C Controller module, refer to the following.

📖 MELSEC iQ-R C Controller Module User's Manual

- When using a MELSECWinCPU module, refer to the following.

📖 MELSEC iQ-R MELSECWinCPU Module User's Manual

Window change between GX Works2 and GX Works3

Windows in GX Works2 for the MELSEC-Q series changes the following windows in GX Works3.

Parameter items

This section describes the window change of parameters. For parameter setting method on GX Works3, refer to the following.

📖 MELSEC iQ-R CPU Module User's Manual (Application)

I/O assignment setting

- "Points", "Start XY", and "PLC Operation Mode at H/W Error" in "I/O Assignment" of GX Works2 change the following window in GX Works3.

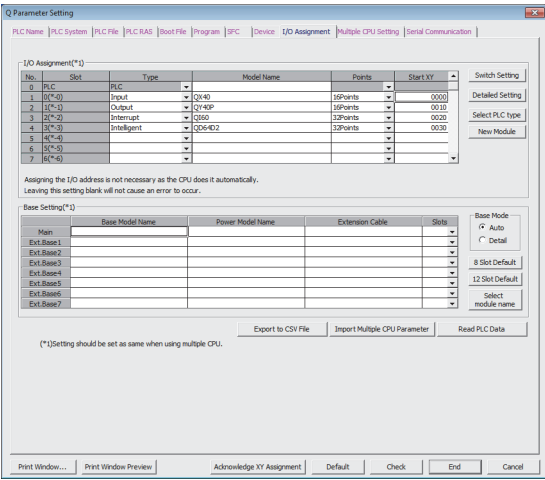
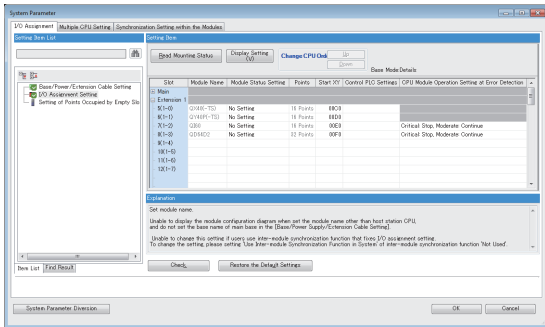
GX Works2	GX Works3																																																																																																																																																																																																																																																																																																																																																																		
<p>☞ [Project window] ⇒ [Parameter] ⇒ [PLC Parameter] ⇒ [I/O Assignment]</p>  <p>I/O Assignment(*1)</p> <table border="1"> <thead> <tr> <th>No.</th> <th>Slot</th> <th>Type</th> <th>Model Name</th> <th>Points</th> <th>Start XY</th> </tr> </thead> <tbody> <tr><td>0</td><td>PLC</td><td></td><td></td><td></td><td></td></tr> <tr><td>1</td><td>[X(*-0)]</td><td>Input</td><td>QV40</td><td>16Points</td><td>0000</td></tr> <tr><td>2</td><td>[Y(*-1)]</td><td>Output</td><td>QY40P</td><td>16Points</td><td>0030</td></tr> <tr><td>3</td><td>[X(*-2)]</td><td>Interrupt</td><td>QI50</td><td>12Points</td><td>0030</td></tr> <tr><td>4</td><td>[X(*-3)]</td><td>Intelligent</td><td>QI54K2</td><td>12Points</td><td>0030</td></tr> <tr><td>5</td><td>[X(*-4)]</td><td></td><td></td><td></td><td></td></tr> <tr><td>6</td><td>[X(*-5)]</td><td></td><td></td><td></td><td></td></tr> <tr><td>7</td><td>[X(*-6)]</td><td></td><td></td><td></td><td></td></tr> </tbody> </table> <p>Base Setting(*1)</p> <table border="1"> <thead> <tr> <th>Base</th> <th>Base Model Name</th> <th>Power Model Name</th> <th>Extension Cable</th> <th>Slot</th> </tr> </thead> <tbody> <tr><td>Main</td><td></td><td></td><td></td><td></td></tr> <tr><td>Ext Base1</td><td></td><td></td><td></td><td></td></tr> <tr><td>Ext Base2</td><td></td><td></td><td></td><td></td></tr> <tr><td>Ext Base3</td><td></td><td></td><td></td><td></td></tr> <tr><td>Ext Base4</td><td></td><td></td><td></td><td></td></tr> <tr><td>Ext Base5</td><td></td><td></td><td></td><td></td></tr> <tr><td>Ext Base6</td><td></td><td></td><td></td><td></td></tr> <tr><td>Ext Base7</td><td></td><td></td><td></td><td></td></tr> </tbody> </table> <p>Intelligent Function Module Detailed Setting</p> <table border="1"> <thead> <tr> <th>Slot</th> <th>Type</th> <th>Model Name</th> <th>Error Time Output Mode</th> <th>PLC Operation Mode at H/W Error</th> <th>I/O Response Time</th> <th>Control PLC(*1)</th> </tr> </thead> <tbody> <tr><td>0</td><td>PLC</td><td></td><td></td><td></td><td></td><td></td></tr> <tr><td>1</td><td>[X(*-0)]</td><td>Input</td><td>QV40</td><td></td><td>10ms</td><td></td></tr> <tr><td>2</td><td>[Y(*-1)]</td><td>Output</td><td>QY40P</td><td>Clear</td><td></td><td></td></tr> <tr><td>3</td><td>[X(*-2)]</td><td>Interrupt</td><td>QI50</td><td>Clear</td><td>0.3ms</td><td></td></tr> <tr><td>4</td><td>[X(*-3)]</td><td>Intelligent</td><td>QI54K2</td><td>Clear</td><td>Stop</td><td></td></tr> <tr><td>5</td><td>[X(*-4)]</td><td></td><td></td><td></td><td></td><td></td></tr> <tr><td>6</td><td>[X(*-5)]</td><td></td><td></td><td></td><td></td><td></td></tr> <tr><td>7</td><td>[X(*-6)]</td><td></td><td></td><td></td><td></td><td></td></tr> <tr><td>8</td><td>[X(*-7)]</td><td></td><td></td><td></td><td></td><td></td></tr> <tr><td>9</td><td>[X(*-8)]</td><td></td><td></td><td></td><td></td><td></td></tr> <tr><td>10</td><td>[X(*-9)]</td><td></td><td></td><td></td><td></td><td></td></tr> <tr><td>11</td><td>[X(*-10)]</td><td></td><td></td><td></td><td></td><td></td></tr> <tr><td>12</td><td>[X(*-11)]</td><td></td><td></td><td></td><td></td><td></td></tr> <tr><td>13</td><td>[X(*-12)]</td><td></td><td></td><td></td><td></td><td></td></tr> <tr><td>14</td><td>[X(*-13)]</td><td></td><td></td><td></td><td></td><td></td></tr> <tr><td>15</td><td>[X(*-14)]</td><td></td><td></td><td></td><td></td><td></td></tr> </tbody> </table>	No.	Slot	Type	Model Name	Points	Start XY	0	PLC					1	[X(*-0)]	Input	QV40	16Points	0000	2	[Y(*-1)]	Output	QY40P	16Points	0030	3	[X(*-2)]	Interrupt	QI50	12Points	0030	4	[X(*-3)]	Intelligent	QI54K2	12Points	0030	5	[X(*-4)]					6	[X(*-5)]					7	[X(*-6)]					Base	Base Model Name	Power Model Name	Extension Cable	Slot	Main					Ext Base1					Ext Base2					Ext Base3					Ext Base4					Ext Base5					Ext Base6					Ext Base7					Slot	Type	Model Name	Error Time Output Mode	PLC Operation Mode at H/W Error	I/O Response Time	Control PLC(*1)	0	PLC						1	[X(*-0)]	Input	QV40		10ms		2	[Y(*-1)]	Output	QY40P	Clear			3	[X(*-2)]	Interrupt	QI50	Clear	0.3ms		4	[X(*-3)]	Intelligent	QI54K2	Clear	Stop		5	[X(*-4)]						6	[X(*-5)]						7	[X(*-6)]						8	[X(*-7)]						9	[X(*-8)]						10	[X(*-9)]						11	[X(*-10)]						12	[X(*-11)]						13	[X(*-12)]						14	[X(*-13)]						15	[X(*-14)]						<p>☞ [Navigation window] ⇒ [Parameter] ⇒ [System Parameter] ⇒ [I/O Assignment Setting]</p>  <p>I/O Assignment</p> <table border="1"> <thead> <tr> <th>Slot</th> <th>Module Name</th> <th>Module Status</th> <th>Setting</th> <th>Points</th> <th>Start XY</th> <th>Control PLC Settings</th> <th>PLC Module Operation Setting or Error Detection</th> </tr> </thead> <tbody> <tr><td>0</td><td>PLC</td><td></td><td></td><td></td><td></td><td></td><td></td></tr> <tr><td>1</td><td>[X(*-0)]</td><td>QV40</td><td>No Setting</td><td>16 Points</td><td>0000</td><td></td><td></td></tr> <tr><td>2</td><td>[Y(*-1)]</td><td>QY40P</td><td>No Setting</td><td>16 Points</td><td>0030</td><td></td><td></td></tr> <tr><td>3</td><td>[X(*-2)]</td><td>QI50</td><td>No Setting</td><td>12 Points</td><td>0030</td><td></td><td>Critical Stop, Moderate Continue</td></tr> <tr><td>4</td><td>[X(*-3)]</td><td>QI54K2</td><td>No Setting</td><td>12 Points</td><td>0030</td><td></td><td>Critical Stop, Moderate Continue</td></tr> <tr><td>5</td><td>[X(*-4)]</td><td></td><td></td><td></td><td></td><td></td><td></td></tr> <tr><td>6</td><td>[X(*-5)]</td><td></td><td></td><td></td><td></td><td></td><td></td></tr> <tr><td>7</td><td>[X(*-6)]</td><td></td><td></td><td></td><td></td><td></td><td></td></tr> <tr><td>8</td><td>[X(*-7)]</td><td></td><td></td><td></td><td></td><td></td><td></td></tr> <tr><td>9</td><td>[X(*-8)]</td><td></td><td></td><td></td><td></td><td></td><td></td></tr> <tr><td>10</td><td>[X(*-9)]</td><td></td><td></td><td></td><td></td><td></td><td></td></tr> <tr><td>11</td><td>[X(*-10)]</td><td></td><td></td><td></td><td></td><td></td><td></td></tr> <tr><td>12</td><td>[X(*-11)]</td><td></td><td></td><td></td><td></td><td></td><td></td></tr> <tr><td>13</td><td>[X(*-12)]</td><td></td><td></td><td></td><td></td><td></td><td></td></tr> <tr><td>14</td><td>[X(*-13)]</td><td></td><td></td><td></td><td></td><td></td><td></td></tr> <tr><td>15</td><td>[X(*-14)]</td><td></td><td></td><td></td><td></td><td></td><td></td></tr> </tbody> </table>	Slot	Module Name	Module Status	Setting	Points	Start XY	Control PLC Settings	PLC Module Operation Setting or Error Detection	0	PLC							1	[X(*-0)]	QV40	No Setting	16 Points	0000			2	[Y(*-1)]	QY40P	No Setting	16 Points	0030			3	[X(*-2)]	QI50	No Setting	12 Points	0030		Critical Stop, Moderate Continue	4	[X(*-3)]	QI54K2	No Setting	12 Points	0030		Critical Stop, Moderate Continue	5	[X(*-4)]							6	[X(*-5)]							7	[X(*-6)]							8	[X(*-7)]							9	[X(*-8)]							10	[X(*-9)]							11	[X(*-10)]							12	[X(*-11)]							13	[X(*-12)]							14	[X(*-13)]							15	[X(*-14)]						
No.	Slot	Type	Model Name	Points	Start XY																																																																																																																																																																																																																																																																																																																																																														
0	PLC																																																																																																																																																																																																																																																																																																																																																																		
1	[X(*-0)]	Input	QV40	16Points	0000																																																																																																																																																																																																																																																																																																																																																														
2	[Y(*-1)]	Output	QY40P	16Points	0030																																																																																																																																																																																																																																																																																																																																																														
3	[X(*-2)]	Interrupt	QI50	12Points	0030																																																																																																																																																																																																																																																																																																																																																														
4	[X(*-3)]	Intelligent	QI54K2	12Points	0030																																																																																																																																																																																																																																																																																																																																																														
5	[X(*-4)]																																																																																																																																																																																																																																																																																																																																																																		
6	[X(*-5)]																																																																																																																																																																																																																																																																																																																																																																		
7	[X(*-6)]																																																																																																																																																																																																																																																																																																																																																																		
Base	Base Model Name	Power Model Name	Extension Cable	Slot																																																																																																																																																																																																																																																																																																																																																															
Main																																																																																																																																																																																																																																																																																																																																																																			
Ext Base1																																																																																																																																																																																																																																																																																																																																																																			
Ext Base2																																																																																																																																																																																																																																																																																																																																																																			
Ext Base3																																																																																																																																																																																																																																																																																																																																																																			
Ext Base4																																																																																																																																																																																																																																																																																																																																																																			
Ext Base5																																																																																																																																																																																																																																																																																																																																																																			
Ext Base6																																																																																																																																																																																																																																																																																																																																																																			
Ext Base7																																																																																																																																																																																																																																																																																																																																																																			
Slot	Type	Model Name	Error Time Output Mode	PLC Operation Mode at H/W Error	I/O Response Time	Control PLC(*1)																																																																																																																																																																																																																																																																																																																																																													
0	PLC																																																																																																																																																																																																																																																																																																																																																																		
1	[X(*-0)]	Input	QV40		10ms																																																																																																																																																																																																																																																																																																																																																														
2	[Y(*-1)]	Output	QY40P	Clear																																																																																																																																																																																																																																																																																																																																																															
3	[X(*-2)]	Interrupt	QI50	Clear	0.3ms																																																																																																																																																																																																																																																																																																																																																														
4	[X(*-3)]	Intelligent	QI54K2	Clear	Stop																																																																																																																																																																																																																																																																																																																																																														
5	[X(*-4)]																																																																																																																																																																																																																																																																																																																																																																		
6	[X(*-5)]																																																																																																																																																																																																																																																																																																																																																																		
7	[X(*-6)]																																																																																																																																																																																																																																																																																																																																																																		
8	[X(*-7)]																																																																																																																																																																																																																																																																																																																																																																		
9	[X(*-8)]																																																																																																																																																																																																																																																																																																																																																																		
10	[X(*-9)]																																																																																																																																																																																																																																																																																																																																																																		
11	[X(*-10)]																																																																																																																																																																																																																																																																																																																																																																		
12	[X(*-11)]																																																																																																																																																																																																																																																																																																																																																																		
13	[X(*-12)]																																																																																																																																																																																																																																																																																																																																																																		
14	[X(*-13)]																																																																																																																																																																																																																																																																																																																																																																		
15	[X(*-14)]																																																																																																																																																																																																																																																																																																																																																																		
Slot	Module Name	Module Status	Setting	Points	Start XY	Control PLC Settings	PLC Module Operation Setting or Error Detection																																																																																																																																																																																																																																																																																																																																																												
0	PLC																																																																																																																																																																																																																																																																																																																																																																		
1	[X(*-0)]	QV40	No Setting	16 Points	0000																																																																																																																																																																																																																																																																																																																																																														
2	[Y(*-1)]	QY40P	No Setting	16 Points	0030																																																																																																																																																																																																																																																																																																																																																														
3	[X(*-2)]	QI50	No Setting	12 Points	0030		Critical Stop, Moderate Continue																																																																																																																																																																																																																																																																																																																																																												
4	[X(*-3)]	QI54K2	No Setting	12 Points	0030		Critical Stop, Moderate Continue																																																																																																																																																																																																																																																																																																																																																												
5	[X(*-4)]																																																																																																																																																																																																																																																																																																																																																																		
6	[X(*-5)]																																																																																																																																																																																																																																																																																																																																																																		
7	[X(*-6)]																																																																																																																																																																																																																																																																																																																																																																		
8	[X(*-7)]																																																																																																																																																																																																																																																																																																																																																																		
9	[X(*-8)]																																																																																																																																																																																																																																																																																																																																																																		
10	[X(*-9)]																																																																																																																																																																																																																																																																																																																																																																		
11	[X(*-10)]																																																																																																																																																																																																																																																																																																																																																																		
12	[X(*-11)]																																																																																																																																																																																																																																																																																																																																																																		
13	[X(*-12)]																																																																																																																																																																																																																																																																																																																																																																		
14	[X(*-13)]																																																																																																																																																																																																																																																																																																																																																																		
15	[X(*-14)]																																																																																																																																																																																																																																																																																																																																																																		

- "Error Time Output Mode" and "I/O Response Time" of GX Works2 have changed to the following windows in GX Works3.

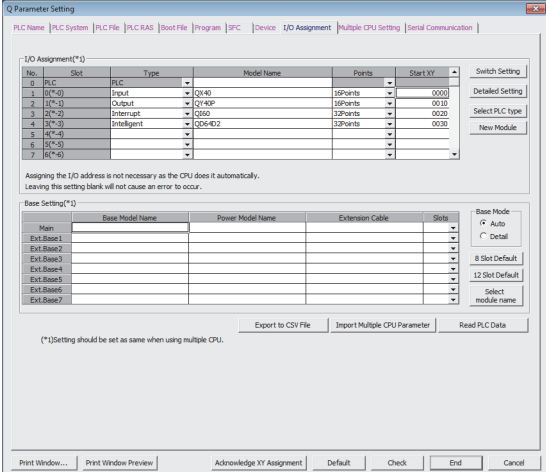
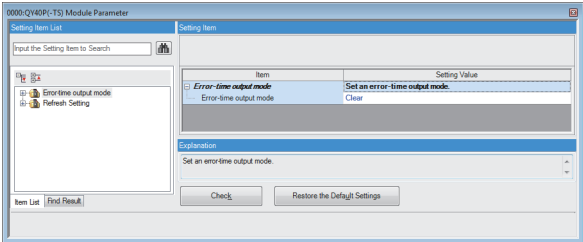
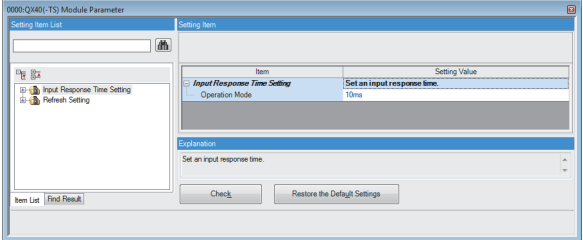
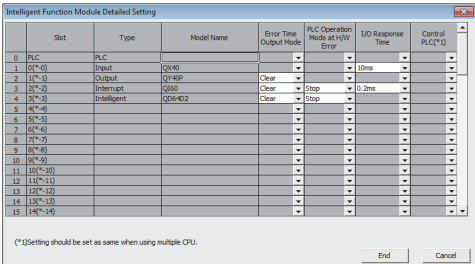
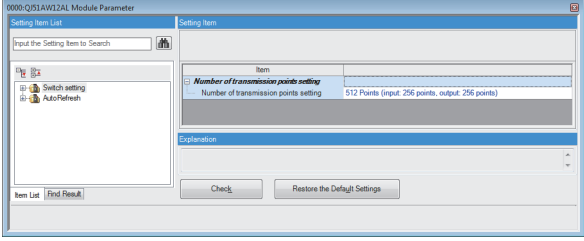
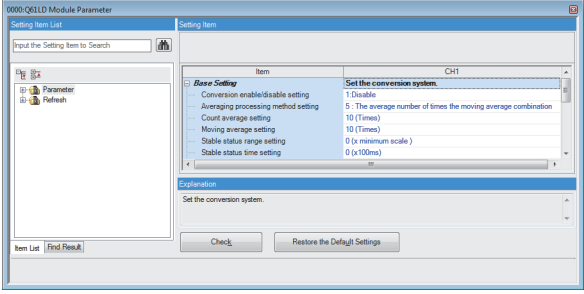
GX Works2	GX Works3																																																																																																																																											
<p>☞ [Project window] ⇒ [Parameter] ⇒ [PLC Parameter] ⇒ [I/O Assignment]</p>  <table border="1" data-bbox="150 360 614 472"> <caption>I/O Assignment</caption> <thead> <tr> <th>No.</th> <th>Slot</th> <th>Type</th> <th>Model Name</th> <th>Points</th> <th>Start XY</th> </tr> </thead> <tbody> <tr><td>0</td><td>PLC</td><td>PLC</td><td></td><td></td><td></td></tr> <tr><td>1</td><td>1(*-1)</td><td>Input</td><td>QI40</td><td>16Points</td><td>0003</td></tr> <tr><td>2</td><td>1(*-1)</td><td>Output</td><td>QI40P</td><td>16Points</td><td>0010</td></tr> <tr><td>3</td><td>2(*-2)</td><td>Interrupt</td><td>QI50</td><td>32Points</td><td>0030</td></tr> <tr><td>4</td><td>3(*-3)</td><td>Intelligent</td><td>QI54I2</td><td>32Points</td><td>0030</td></tr> <tr><td>5</td><td>4(*-4)</td><td></td><td></td><td></td><td></td></tr> <tr><td>6</td><td>5(*-5)</td><td></td><td></td><td></td><td></td></tr> <tr><td>7</td><td>6(*-6)</td><td></td><td></td><td></td><td></td></tr> </tbody> </table> <p>Assigning the I/O address is not necessary as the CPU does it automatically. Leaving this setting blank will not cause an error to occur.</p> <p>Base Setting</p> <table border="1" data-bbox="150 510 614 622"> <thead> <tr> <th>Base</th> <th>Base Model Name</th> <th>Power Model Name</th> <th>Extension Cable</th> <th>Slots</th> <th>Base Mode</th> </tr> </thead> <tbody> <tr><td>Main</td><td></td><td></td><td></td><td></td><td>Auto</td></tr> <tr><td>Ext Base1</td><td></td><td></td><td></td><td></td><td>Default</td></tr> <tr><td>Ext Base2</td><td></td><td></td><td></td><td></td><td>8 Slot Default</td></tr> <tr><td>Ext Base3</td><td></td><td></td><td></td><td></td><td>12 Slot Default</td></tr> <tr><td>Ext Base4</td><td></td><td></td><td></td><td></td><td>Select module name</td></tr> <tr><td>Ext Base5</td><td></td><td></td><td></td><td></td><td></td></tr> <tr><td>Ext Base6</td><td></td><td></td><td></td><td></td><td></td></tr> <tr><td>Ext Base7</td><td></td><td></td><td></td><td></td><td></td></tr> </tbody> </table> <p>Export to CSV File Import Multiple CPU Parameter Read PLC Data</p> <p>(*1)Setting should be set as same when using multiple CPU.</p>	No.	Slot	Type	Model Name	Points	Start XY	0	PLC	PLC				1	1(*-1)	Input	QI40	16Points	0003	2	1(*-1)	Output	QI40P	16Points	0010	3	2(*-2)	Interrupt	QI50	32Points	0030	4	3(*-3)	Intelligent	QI54I2	32Points	0030	5	4(*-4)					6	5(*-5)					7	6(*-6)					Base	Base Model Name	Power Model Name	Extension Cable	Slots	Base Mode	Main					Auto	Ext Base1					Default	Ext Base2					8 Slot Default	Ext Base3					12 Slot Default	Ext Base4					Select module name	Ext Base5						Ext Base6						Ext Base7						<p>☞ [Navigation window] ⇒ [Parameter] ⇒ [Module Information] ⇒ Module model name ⇒ [Module Parameter]</p>  <p>0000:QI40P(-TS) Module Parameter</p> <p>Setting Item List</p> <table border="1" data-bbox="815 405 1401 472"> <thead> <tr> <th>Item</th> <th>Setting Value</th> </tr> </thead> <tbody> <tr> <td>Error-time output mode</td> <td>Set an error-time output mode.</td> </tr> <tr> <td>Error-time output mode</td> <td>Clear</td> </tr> </tbody> </table> <p>Explanation</p> <p>Set an error-time output mode.</p> <p>Item List [Find Result]</p> <p>Check Restore the Default Settings</p>  <p>0000:QI40(-TS) Module Parameter</p> <p>Setting Item List</p> <table border="1" data-bbox="815 678 1401 745"> <thead> <tr> <th>Item</th> <th>Setting Value</th> </tr> </thead> <tbody> <tr> <td>Input Response Time Setting</td> <td>Set an input response time.</td> </tr> <tr> <td>Operation Mode</td> <td>10ms</td> </tr> </tbody> </table> <p>Explanation</p> <p>Set an input response time.</p> <p>Item List [Find Result]</p> <p>Check Restore the Default Settings</p>	Item	Setting Value	Error-time output mode	Set an error-time output mode.	Error-time output mode	Clear	Item	Setting Value	Input Response Time Setting	Set an input response time.	Operation Mode	10ms																			
No.	Slot	Type	Model Name	Points	Start XY																																																																																																																																							
0	PLC	PLC																																																																																																																																										
1	1(*-1)	Input	QI40	16Points	0003																																																																																																																																							
2	1(*-1)	Output	QI40P	16Points	0010																																																																																																																																							
3	2(*-2)	Interrupt	QI50	32Points	0030																																																																																																																																							
4	3(*-3)	Intelligent	QI54I2	32Points	0030																																																																																																																																							
5	4(*-4)																																																																																																																																											
6	5(*-5)																																																																																																																																											
7	6(*-6)																																																																																																																																											
Base	Base Model Name	Power Model Name	Extension Cable	Slots	Base Mode																																																																																																																																							
Main					Auto																																																																																																																																							
Ext Base1					Default																																																																																																																																							
Ext Base2					8 Slot Default																																																																																																																																							
Ext Base3					12 Slot Default																																																																																																																																							
Ext Base4					Select module name																																																																																																																																							
Ext Base5																																																																																																																																												
Ext Base6																																																																																																																																												
Ext Base7																																																																																																																																												
Item	Setting Value																																																																																																																																											
Error-time output mode	Set an error-time output mode.																																																																																																																																											
Error-time output mode	Clear																																																																																																																																											
Item	Setting Value																																																																																																																																											
Input Response Time Setting	Set an input response time.																																																																																																																																											
Operation Mode	10ms																																																																																																																																											
<p>☞ [Project window] ⇒ [Parameter] ⇒ [Intelligent Function Module] ⇒ Module model name</p>  <p>Intelligent Function Module Detailed Setting</p> <table border="1" data-bbox="150 835 627 1037"> <thead> <tr> <th>Slot</th> <th>Type</th> <th>Model Name</th> <th>Error Time Output Mode</th> <th>PLC Operation Mode at H/W Error</th> <th>I/O Response Time</th> <th>Control PLC(I/O)</th> </tr> </thead> <tbody> <tr><td>0</td><td>PLC</td><td>PLC</td><td></td><td></td><td></td><td></td></tr> <tr><td>1</td><td>1(*-1)</td><td>Input</td><td>QI40</td><td></td><td>10ms</td><td></td></tr> <tr><td>2</td><td>1(*-1)</td><td>Output</td><td>QI40P</td><td>Clear</td><td></td><td></td></tr> <tr><td>3</td><td>2(*-2)</td><td>Interrupt</td><td>QI50</td><td>Clear</td><td>0.3ms</td><td></td></tr> <tr><td>4</td><td>3(*-3)</td><td>Intelligent</td><td>QI54I2</td><td>Clear</td><td></td><td></td></tr> <tr><td>5</td><td>4(*-4)</td><td></td><td></td><td></td><td></td><td></td></tr> <tr><td>6</td><td>5(*-5)</td><td></td><td></td><td></td><td></td><td></td></tr> <tr><td>7</td><td>6(*-6)</td><td></td><td></td><td></td><td></td><td></td></tr> <tr><td>8</td><td>7(*-7)</td><td></td><td></td><td></td><td></td><td></td></tr> <tr><td>9</td><td>8(*-8)</td><td></td><td></td><td></td><td></td><td></td></tr> <tr><td>10</td><td>9(*-9)</td><td></td><td></td><td></td><td></td><td></td></tr> <tr><td>11</td><td>10(*-10)</td><td></td><td></td><td></td><td></td><td></td></tr> <tr><td>12</td><td>11(*-11)</td><td></td><td></td><td></td><td></td><td></td></tr> <tr><td>13</td><td>12(*-12)</td><td></td><td></td><td></td><td></td><td></td></tr> <tr><td>14</td><td>13(*-13)</td><td></td><td></td><td></td><td></td><td></td></tr> <tr><td>15</td><td>14(*-14)</td><td></td><td></td><td></td><td></td><td></td></tr> </tbody> </table> <p>(*1)Setting should be set as same when using multiple CPU.</p> <p>End Cancel</p>	Slot	Type	Model Name	Error Time Output Mode	PLC Operation Mode at H/W Error	I/O Response Time	Control PLC(I/O)	0	PLC	PLC					1	1(*-1)	Input	QI40		10ms		2	1(*-1)	Output	QI40P	Clear			3	2(*-2)	Interrupt	QI50	Clear	0.3ms		4	3(*-3)	Intelligent	QI54I2	Clear			5	4(*-4)						6	5(*-5)						7	6(*-6)						8	7(*-7)						9	8(*-8)						10	9(*-9)						11	10(*-10)						12	11(*-11)						13	12(*-12)						14	13(*-13)						15	14(*-14)						<p>☞ [Navigation window] ⇒ [Parameter] ⇒ [Module Information] ⇒ Module model name ⇒ [Module Parameter]</p>  <p>0000:QI54I2AL Module Parameter</p> <p>Setting Item List</p> <table border="1" data-bbox="815 1485 1401 1552"> <thead> <tr> <th>Item</th> <th>Setting Value</th> </tr> </thead> <tbody> <tr> <td>Number of transmission points setting</td> <td>512 Points (input: 256 points, output: 256 points)</td> </tr> </tbody> </table> <p>Explanation</p> <p>Item List [Find Result]</p> <p>Check Restore the Default Settings</p>  <p>0000:QI51LD Module Parameter</p> <p>Setting Item List</p> <table border="1" data-bbox="815 1753 1401 1910"> <thead> <tr> <th>Item</th> <th>Setting Value</th> </tr> </thead> <tbody> <tr> <td>Base Setting</td> <td>Set the conversion system.</td> </tr> <tr> <td>Conversion enable/disable setting</td> <td>1 (Disable)</td> </tr> <tr> <td>Averaging processing method setting</td> <td>5. The average number of times the moving average combination</td> </tr> <tr> <td>Count average setting</td> <td>10 (Times)</td> </tr> <tr> <td>Moving average setting</td> <td>10 (Times)</td> </tr> <tr> <td>Stable status range setting</td> <td>0 (x minimum scale)</td> </tr> <tr> <td>Stable status time setting</td> <td>0 (x100ms)</td> </tr> </tbody> </table> <p>Explanation</p> <p>Set the conversion system.</p> <p>Item List [Find Result]</p> <p>Check Restore the Default Settings</p>	Item	Setting Value	Number of transmission points setting	512 Points (input: 256 points, output: 256 points)	Item	Setting Value	Base Setting	Set the conversion system.	Conversion enable/disable setting	1 (Disable)	Averaging processing method setting	5. The average number of times the moving average combination	Count average setting	10 (Times)	Moving average setting	10 (Times)	Stable status range setting	0 (x minimum scale)	Stable status time setting	0 (x100ms)
Slot	Type	Model Name	Error Time Output Mode	PLC Operation Mode at H/W Error	I/O Response Time	Control PLC(I/O)																																																																																																																																						
0	PLC	PLC																																																																																																																																										
1	1(*-1)	Input	QI40		10ms																																																																																																																																							
2	1(*-1)	Output	QI40P	Clear																																																																																																																																								
3	2(*-2)	Interrupt	QI50	Clear	0.3ms																																																																																																																																							
4	3(*-3)	Intelligent	QI54I2	Clear																																																																																																																																								
5	4(*-4)																																																																																																																																											
6	5(*-5)																																																																																																																																											
7	6(*-6)																																																																																																																																											
8	7(*-7)																																																																																																																																											
9	8(*-8)																																																																																																																																											
10	9(*-9)																																																																																																																																											
11	10(*-10)																																																																																																																																											
12	11(*-11)																																																																																																																																											
13	12(*-12)																																																																																																																																											
14	13(*-13)																																																																																																																																											
15	14(*-14)																																																																																																																																											
Item	Setting Value																																																																																																																																											
Number of transmission points setting	512 Points (input: 256 points, output: 256 points)																																																																																																																																											
Item	Setting Value																																																																																																																																											
Base Setting	Set the conversion system.																																																																																																																																											
Conversion enable/disable setting	1 (Disable)																																																																																																																																											
Averaging processing method setting	5. The average number of times the moving average combination																																																																																																																																											
Count average setting	10 (Times)																																																																																																																																											
Moving average setting	10 (Times)																																																																																																																																											
Stable status range setting	0 (x minimum scale)																																																																																																																																											
Stable status time setting	0 (x100ms)																																																																																																																																											

Switch setting and intelligent function module parameter

"Switch Setting" and the intelligent function module parameter of GX Works2 have changed to the following windows in GX Works3.

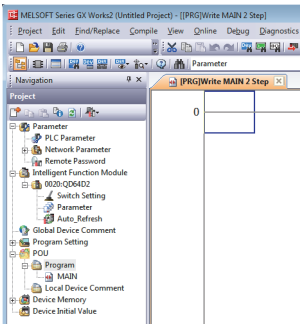
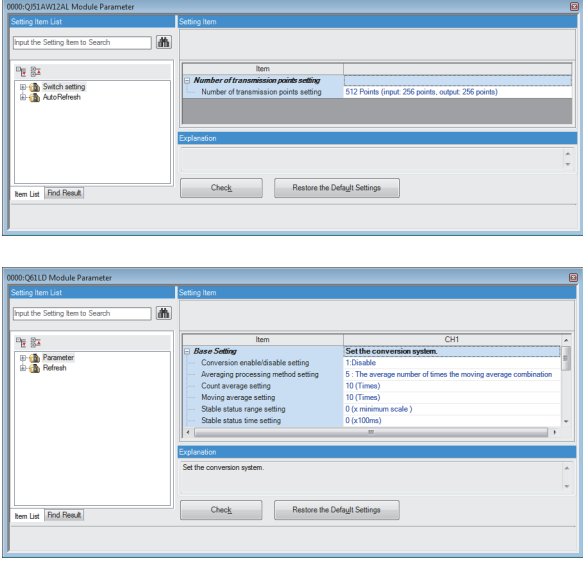
GX Works2	GX Works3																
<p>☞ [Project window] ⇒ [Intelligent Function Module] ⇒ Module model name</p>  <p>MELSOFT Series GX Works2 (Untitled Project) - [PRG]Write MAIN 2 Step</p> <p>Parameter</p> <ul style="list-style-type: none"> PLC Parameter Network Parameter Remote Password Intelligent Function Module <ul style="list-style-type: none"> Parameter Auto_Refresh Global Device Comment Program Setting POU Program <ul style="list-style-type: none"> MAIN Local Device Comment Device Memory Device Initial Value 	<p>☞ [Navigation window] ⇒ [Parameter] ⇒ [Module Information] ⇒ Module model name ⇒ [Module Parameter]</p>  <p>0000:QI51LD Module Parameter</p> <p>Setting Item List</p> <table border="1" data-bbox="815 1753 1401 1910"> <thead> <tr> <th>Item</th> <th>Setting Value</th> </tr> </thead> <tbody> <tr> <td>Base Setting</td> <td>Set the conversion system.</td> </tr> <tr> <td>Conversion enable/disable setting</td> <td>1 (Disable)</td> </tr> <tr> <td>Averaging processing method setting</td> <td>5. The average number of times the moving average combination</td> </tr> <tr> <td>Count average setting</td> <td>10 (Times)</td> </tr> <tr> <td>Moving average setting</td> <td>10 (Times)</td> </tr> <tr> <td>Stable status range setting</td> <td>0 (x minimum scale)</td> </tr> <tr> <td>Stable status time setting</td> <td>0 (x100ms)</td> </tr> </tbody> </table> <p>Explanation</p> <p>Set the conversion system.</p> <p>Item List [Find Result]</p> <p>Check Restore the Default Settings</p>	Item	Setting Value	Base Setting	Set the conversion system.	Conversion enable/disable setting	1 (Disable)	Averaging processing method setting	5. The average number of times the moving average combination	Count average setting	10 (Times)	Moving average setting	10 (Times)	Stable status range setting	0 (x minimum scale)	Stable status time setting	0 (x100ms)
Item	Setting Value																
Base Setting	Set the conversion system.																
Conversion enable/disable setting	1 (Disable)																
Averaging processing method setting	5. The average number of times the moving average combination																
Count average setting	10 (Times)																
Moving average setting	10 (Times)																
Stable status range setting	0 (x minimum scale)																
Stable status time setting	0 (x100ms)																

Interrupt pointer setting

"Interrupt Pointer Setting" of GX Works2 changes the following window in GX Works3.

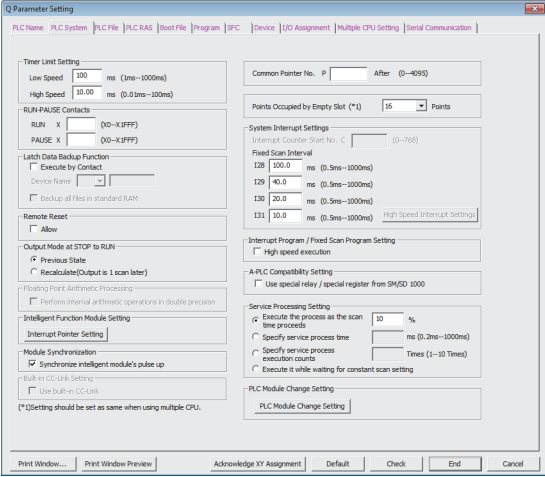
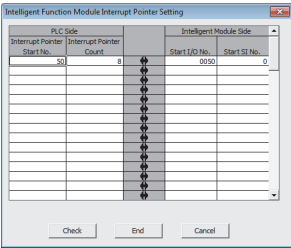
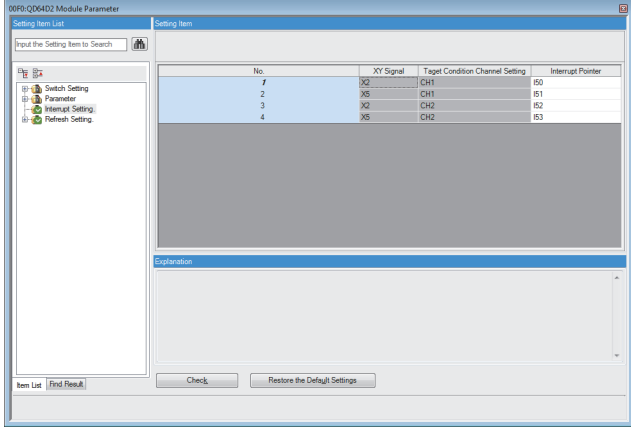
GX Works2	GX Works3
<p>☞ [Project window] ⇒ [Parameter] ⇒ [PLC Parameter] ⇒ [PLC System] ⇒ [Interrupt Pointer Setting]</p>  	<p>☞ [Navigation window] ⇒ [Parameter] ⇒ [Module Information] ⇒ Module model name ⇒ [Module Parameter]</p> 

The interrupt pointer setting method differs as below between GX Works2 and GX Works3.

- The SI No. setting of the interrupt module is not required on GX Works3.
- "Interrupt Pointer" of the interrupt module must be the serial number on GX Works3. (Set I51 on No.2 and I52 on No.3 when No.1 is set I50.)

Network parameter

"Network Parameter" of GX Works2 changes to the following window in GX Works3.

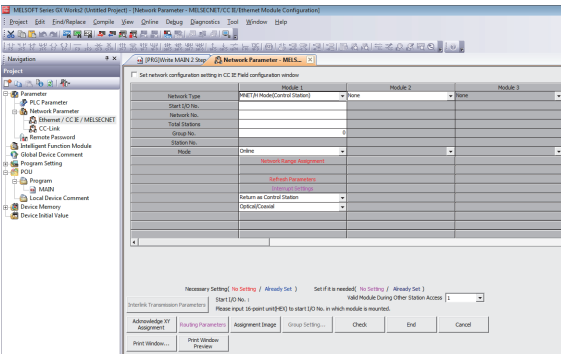
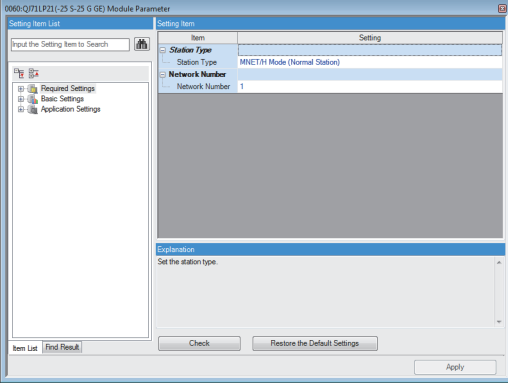
GX Works2	GX Works3
<p>[Project window] ⇒ [Parameter] ⇒ [Network Parameter] ⇒ Network used</p>  <p>The screenshot shows the 'Network Parameter' dialog box in GX Works2. It has a tree view on the left with 'Network Parameter' selected. The main area is titled 'Set network configuration settings in CC-Link Field configuration window' and contains a table with columns for 'Module 1', 'Module 2', and 'Module 3'. The table has rows for 'Network Type', 'Start I/O No.', 'Network No.', 'Start Station', 'Group No.', and 'Station No.'. Below the table are buttons for 'Check', 'End', and 'Cancel'.</p>	<p>[Navigation window] ⇒ [Parameter] ⇒ [Module Information] ⇒ Module model name ⇒ [Module Parameter]</p>  <p>The screenshot shows the 'Module Parameter' dialog box in GX Works3. It has a 'Setting Item List' on the left and a 'Setting Item' table on the right. The table has columns for 'Item' and 'Setting'. The 'Item' column has 'Station Type' and 'Network Number' selected. The 'Setting' column has 'MNET14 Mode (Normal Station)' and '1' respectively. Below the table are buttons for 'Check', 'Restore the Default Settings', and 'Apply'.</p>

Intelligent function module tool

"Intelligent Function Module Tool" of GX Works2 changes the following window in GX Works3.

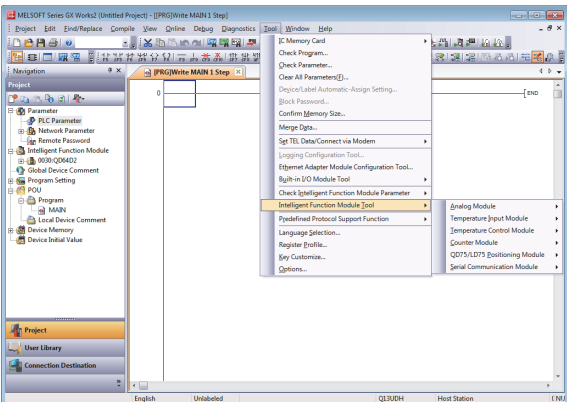
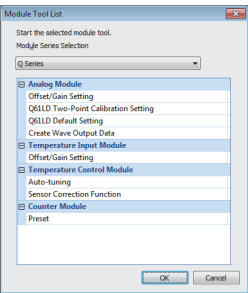
GX Works2	GX Works3
<p>[Tool] ⇒ [Intelligent Function Module Tool] ⇒ Each module tool</p>  <p>The screenshot shows the 'Intelligent Function Module Tool' menu in GX Works2. The menu is open, showing options like 'Analog Module', 'Digital Input Module', 'Temperature Input Module', etc. The 'Intelligent Function Module Tool' option is highlighted.</p>	<p>[Tool] ⇒ [Module Tool List] ⇒ [Q Series] ⇒ Each module tool</p>  <p>The screenshot shows the 'Module Tool List' dialog box in GX Works3. It has a 'Module Series Selection' dropdown set to 'Q Series'. Below it is a list of module tools, including 'Analog Module', 'Temperature Input Module', and 'Counter Module'. The 'Analog Module' is selected. At the bottom are 'OK' and 'Cancel' buttons.</p>



Setting procedure

This section describes the setting procedure for the MELSEC-Q series module in GX Works3.

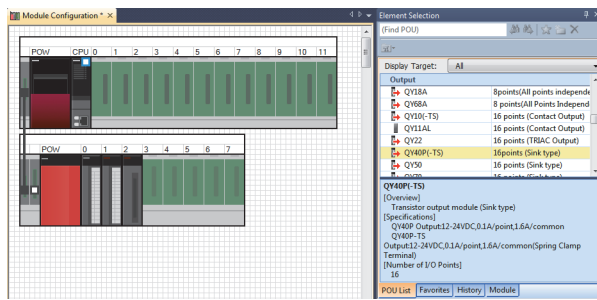

1. Create the module configuration in accordance with the actual configuration by dragging and dropping each MELSEC-Q series module from the "Element Selection" window of "Module Configuration" in GX Works3. Then, select [Edit] ⇒ [Parameter] ⇒ [Fix].*1*2

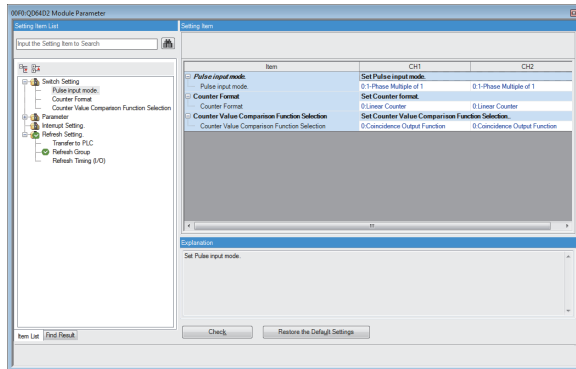

2. Set the module parameters of each module.
 [Navigation window] ⇒ [Parameter] ⇒ [Module Information] ⇒ Module model name ⇒ [Module Parameter]

*1 When the CPU module used can be connected to GX Works3, the actual system configuration can be read out by selecting [Online] ⇒ [Read Module Configuration from PLC] in the menu. For the modules which cannot be read out, create the module configuration by dragging and dropping each module from "Element Selection" window.

*2 When "Points", "Start XY", or "CPU Module Operation Setting at Error Detection" are changed, set the parameters in "System Parameter". (Page 248 Parameter items)

Product classification in "Module Configuration"

The models are classified into the following.

Model	Product classification in "Module Configuration"	Remarks
Q52B, Q55B, Q63B, Q65B, Q68B, Q612B, Q55BL* ¹ , Q65BL* ¹ , Q68BL* ¹ , Q55BLS* ² , Q65BLS* ² , Q68BLS* ² , Q55BLS-D* ² , Q65BLS-D* ² , Q68BLS-D* ²	Extension Base	—
QC05B, QC06B, QC12B, QC30B, QC50B, QC100B	Connection line* ³	—
Q61P, Q61P-A1, Q61P-A2, Q62P, Q63P, Q64P, Q64PN, Q61P-D	Power Supply	—
QX10, QX10-TS, QX28, QX40, QX40-TS, QX40-S1, QX41, QX41-S1, QX41-S2, QX42, QX42-S1, QX70, QX71, QX72, QX80, QX80-TS, QX81, QX81-S2, QX82, QX82-S1, QX40H, QX70H, QX80H, QX90H, QX50, QX11L* ⁴ , QX21L* ⁴	Input	—
QY10, QY10-TS, QY18A, QY22, QY40P, QY40P-TS, QY41P, QY42P, QY50, QY68A, QY70, QY71, QY80, QY80-TS, QY81P, QY82P, QY41H, QY11AL* ⁵ , QY13L* ⁵ , QY23L* ⁵ , QY51PL* ⁵	Output	—
QH42P, QX48Y57, QX41Y41P	I/O	—
QI60	Interrupt Input	—
Q61LD, Q62AD-DGH, Q64AD, Q68ADV, Q68ADI, Q64AD-GH, Q64ADH, Q66AD-DG, Q68AD-G, Q68CT	Analog Input	Analog-digital converter modules and current transformer input modules are classified into this category.
Q62DA, Q62DAN, Q64DA, Q64DAN, Q68DAV, Q68DAVN, Q68DAI, Q68DAIN, Q62DA-FG, Q66DA-G, Q64DAH	Analog Output	Digital-analog converter modules are classified into this category.
Q64AD2DA	Analog I/O	—
Q64RD, Q64RD-G, Q68RD3-G, Q64TD, Q64TDV-GH, Q68TD-G-H01, Q68TD-G-H02	Temperature Input	—
Q64TCTTN, Q64TCRTN, Q64TCTTBWN, Q64TCRTBWN	Temperature Control Module	—
Q62HLC	Loop Control	—
QD70P4, QD70P8, QD70D4, QD70D8, QD73A1, QD64D2, QD65PD2, QD72P3C3, QD63P6, QD60P8-G	Pulse I/O/Positioning	Positioning modules, high-speed counter modules, and pulse input modules are classified into this category.
QE81WH, QE84WH, QE81WH4W, QE83WH4W, QE82LG	Energy Measuring Module	—
QD51, QD51-R24, QJ71MES96, QJ71MES96N, QJ71WS96	Information Module	MES interface modules and Web server modules are classified into this category.
QJ51AW12AL, QJ61CL12, QJ71AS92, QJ71FL71, QJ71FL71-T, QJ71FL71-B2, QJ71FL71-B5, QJ71FL71-F01, QJ71FL71-T-F01, QJ71FL71-B2-F01, QJ71FL71-B5-F01, QJ71MB91, QJ71MT91, QJ71LP21, QJ71LP21-25, QJ71LP21S-25, QJ71LP21G, QJ71LP21GE, QJ71BR11, QJ71NT11B	Network module	CC-Link/LT master modules and MELSECNET/H network modules are classified into this category.
QJ51AW12D2* ³	Partner product	—
QG60	Blank cover	—

*1 Q series large type extension base unit

*2 Q series large type extension base unit (AnS series size)

*3 A model is not displayed on "Element Selection" window of "Module Configuration".

*4 Large type input module

*5 Large type output module

A

Refresh processing time

The refresh processing time [μs] is a constituent of the scan time of the CPU module. For details on the scan time, refer to the following.

 MELSEC iQ-R CPU Module User's Manual (Application)

The refresh processing time [μs], which is taken for refresh, is given by:

- Refresh processing time [μs] = Refresh read time (time for transferring refresh data to the CPU module) + Refresh write time (time for transferring refresh data to the intelligent function module)

The refresh read time and refresh write time vary depending on the settings of "Target".

When "Target" is a refresh data register (RD)

The following table shows the refresh read time and refresh write time with a MELSEC iQ-R series CPU module used.

Module	Model	RQ extension base unit		Q extension base unit	
		Read time	Write time	Read time	Write time
Analog-digital converter module	Q64AD	32.93 μs	0 μs	47.69 μs	0 μs
	Q68ADV, Q68ADI	35.97 μs	0 μs	54.97 μs	0 μs
Channel isolated high resolution analog-digital converter module	Q64AD-GH	45.80 μs	0 μs	77.91 μs	0 μs
channel isolated high resolution analog-digital converter module (with signal conditioning function)	Q62AD-DGH	41.24 μs	0 μs	66.99 μs	0 μs
Channel isolated analog-digital converter module	Q68AD-G	40.76 μs	0 μs	64.64 μs	0 μs
Channel isolated analog-digital converter module (with signal conditioning function)	Q66AD-DG	38.48 μs	0 μs	59.18 μs	0 μs
High speed analog-digital converter module	Q64ADH	58.32 μs	39.08 μs	103.09 μs	65.02 μs
Digital-analog converter module	Q62DA, Q62DAN	26.09 μs	22.89 μs	31.31 μs	29.94 μs
	Q64DA, Q64DAN	26.09 μs	23.75 μs	31.31 μs	26.76 μs
	Q68DAV, Q68DAVN, Q68DAI, Q68DAIN	26.09 μs	25.47 μs	31.31 μs	30.40 μs
Channel isolated digital-analog converter module	Q62DA-FG	35.92 μs	22.89 μs	54.25 μs	24.94 μs
	Q66DA-G	27.94 μs	24.61 μs	35.14 μs	28.58 μs
High speed digital-analog converter module	Q64DAH	29.79 μs	23.75 μs	38.97 μs	26.76 μs
Analog input/output module	Q64AD2DA	239.35 μs	43.35 μs	538.41 μs	75.22 μs
Load cell input module	Q61LD	59.10 μs	0 μs	109.76 μs	0 μs
Current transformer input module	Q68CT	153.34 μs	58.12 μs	335.44 μs	100.66 μs
RTD input module	Q64RD	33.64 μs	0 μs	48.79 μs	0 μs
Channel isolated RTD input module	Q64RD-G	34.02 μs	0 μs	49.70 μs	0 μs
	Q68RD3-G	40.91 μs	0 μs	19.71 μs	0 μs
Thermocouple input module	Q64TD	39.39 μs	0 μs	63.16 μs	0 μs
Channel isolated thermocouple/micro voltage input module	Q64TDV-GH	30.60 μs	0 μs	41.51 μs	0 μs
Channel isolated thermocouple input module	Q68TD-G-H01, Q68TD-G-H02	33.26 μs	0 μs	47.88 μs	0 μs
Temperature control module	Q64TCTTN, Q64TCRTN	323.58 μs	50.91 μs	743.12 μs	98.20 μs
	Q64TCTTBWN, Q64TCRTBWN	323.58 μs	52.63 μs	743.12 μs	101.84 μs
Loop control module	Q62HLC	49.02 μs	32.26 μs	83.22 μs	48.26 μs
Multichannel high-speed counter module	QD63P6	61.13 μs	0 μs	111.62 μs	0 μs
4Mpps capable high-speed counter module	QD64D2	37.62 μs	0 μs	55.92 μs	0 μs
Channel isolated pulse input module	QD60P8-G	108.96 μs	0 μs	225.56 μs	0 μs
Multi function counter/timer module	QD65PD2	159.83 μs	0 μs	346.78 μs	0 μs
Positioning module	QD70P4, QD70D4	54.24 μs	0 μs	94.52 μs	0 μs
	QD70P8, QD70D8	87.28 μs	0 μs	168.84 μs	0 μs
	QD73A1	28.75 μs	0 μs	37.68 μs	0 μs
Positioning module with built-in counter function	QD72P3C3	35.87 μs	0 μs	53.53 μs	0 μs
AS-i master module	QJ71AS92	164.82 μs	174.32 μs	359.33 μs	369.23 μs

Module	Model	RQ extension base unit		Q extension base unit	
		Read time	Write time	Read time	Write time
AnyWireASLINK master module	QJ51AW12AL	28.75μs	23.51μs	37.68μs	31.72μs
Energy measuring module	QE81WH	83.93μs	0μs	166.22μs	0μs
	QE84WH	326.44μs	0μs	729.56μs	0μs
	QE81WH4W	91.48μs	0μs	183.70μs	0μs
	QE83WH4W	286.36μs	0μs	635.98μs	0μs
Insulation monitoring module	QE82LG	139.66μs	0μs	302.68μs	0μs

When "Target" is a specified device

Calculate the refresh read time and refresh write time according to the number of items and the number of their transfer data (word) that are set to be refreshed. For the calculation method, refer to the following.

 MELSEC iQ-R CPU Module User's Manual (Application)

Precautions

This section describes precautions for using the following modules.

For details, refer to the manual for the module used.

Base unit

In "Module Name" on the "System Monitor" window, the model of each extension base unit is not displayed but "Extension Base" is displayed.

■Q series large type extension base unit and Q series large type extension base unit (AnS series size)

Select the module which can be used to each extension base unit on "Module Configuration". When the Q series large type blank cover is used, select the module with the Q series large type blank cover.

Power supply module

In "Module Name" on the "System Monitor" window, the model of each power supply module is not displayed but "Power" is displayed.

I/O modules

■High-speed input modules

- When a high-speed input module is used as a high-speed input module, select the following model in "Module Configuration" in accordance with on or off of a noise filter. (The module operates with the default setting (input response time: 0.2ms) when on or off of the noise filter does not correspond to on or off of the model on "Module Configuration".)

Model	Model displayed on GX Works3	
	When the noise filter is turned on	When the noise filter is turned off
QX40H	QX40H(NoiseF_ON)	QX40H(NoiseF_OFF)
QX70H	QX70H(NoiseF_ON)	QX70H(NoiseF_OFF)
QX80H	QX80H(NoiseF_ON)	QX80H(NoiseF_OFF)
QX90H	QX90H(NoiseF_ON)	QX90H(NoiseF_OFF)

- When a high-speed input module is used as an interrupt module, select "QI60" in "Module Configuration". (The module operates with the default setting (input response time: 0.2ms) when the noise filter is used at off.)
- When high-speed input modules are used as interrupt modules, set the number of modules to be used in "I/O Assignment Setting" in the [I/O Assignment] tab on the "System Parameter" window.

■Interrupt modules

- When multiple interrupt modules are used, set the number of modules to be used in "I/O Assignment Setting" in the [I/O Assignment] tab on the "System Parameter" window.

■Large type AC input module, large type contact output module, large type triac output module, and large type transistor output module

- Place the module that can be mounted on the extension base unit on the "Module Configuration" window.

Analog-digital converter module

Logging data A/B side storage complete pointer detection, an interrupt factor of the Q64ADH, cannot be used as an interrupt pointer.

High-speed counter modules and pulse input modules

Check the latest error code with the system monitor because error codes for the QD63P6 and QD60P8-G cannot be checked in the module diagnostics. When multiple errors occur, refer to the buffer memory and check the error.

Positioning module

- Set parameters in a program because positioning data cannot be written to the module. The positioning data parameter is discarded when the GX Works2 project is read out.
- Check the latest error code with the system monitor because error codes for the QD70P4, QD70P8, QD70D4, and QD70D8 cannot be checked in the module diagnostics. When multiple errors occur, refer to the buffer memory (error codes for each axis) and check the error.

Loop control module

Check the latest error code with the system monitor because error codes for the Q62HLC cannot be checked in the module diagnostics. When multiple errors occur, refer to the buffer memory and check the error.

FL-net(OPCN-2) interface module

- Select "Online" in "Operation Mode Setting" of "Switch Setting".
- Set parameters in a program because the auto refresh used in GX Works2 cannot be set in GX Works3.
- In GX Works2, the size of region 1 of cyclic data is set in units of bits, while in GX Works3, it is set in units of words.

MODBUS interface module and MODBUS/TCP interface module

- When "Start MODBUS device number" of "MODBUS device assignment parameter" is set, check the setting range in the manual in advance.
- For "Basic parameter starting method" and "Device assignment parameter starting method" of "Switch setting" in "Basic setting", only "Start by user setting parameter" can be selected. Write a program to set the automatic communication parameters as well as module parameters set only "Switch setting" when the default assignment parameter is used as the starting method.
- GX Works3 does not support the intelligent function module parameter "Setting for GX Works2 Connection" of GX Works2.
- Accessing via MODBUS using GX Works3 is not allowed.
- The Z(P).MBRW and Z(P).MBREQ instructions cannot be used. Instead of these instructions, use the automatic communication function.
- Set parameters in a program because the auto refresh used in GX Works2 cannot be set in GX Works3.

AnyWireASLINK master module and AnyWire DB A20 master module

- Set a slave module by using the address writer because GX Works3 does not support "AnyWireASLINK Configuration" of GX Works2.
- The auto-generation of a global label (CSV file output from the device assignment window) cannot be use.
- When the AnyWire DB A20 master module is used, select the following model displayed on "Module Configuration". The model is also displayed on the diagnostic window.

Model	Model displayed on GX Works3
QJ51AW12D2	MELSEC_Partner

MES interface module and Web server module

There are restrictions on the supported MELSEC iQ-R series CPU modules. For the modules, refer to the following.

 MES Interface Module User's Manual

 Web Server Module User's Manual

Intelligent communication module

- The SW1VD-AD51HP software package can be used as well as the MELSEC-Q series.
- When the PCRD instruction of the BASIC program is used, there are restrictions on the following processing codes. The codes other than the following can be used as well as when using the MELSEC-Q series CPU module.

Processing code	Restriction
513 (&H201)	Not available
515 (&H203)	The device range of a MELSEC-Q series CPU module only can be used.
516 (&H204)	
533 (&H215)	The buffer memory of a MELSEC iQ-R series module cannot be read out.

- When the PCWT instruction of the BASIC program is used, there are restrictions on the following processing codes. The codes other than the following can be used as well as when using the MELSEC-Q series CPU module.

Processing code	Restriction
515 (&H203)	The device range of a MELSEC-Q series CPU module only can be used.
516 (&H204)	
533 (&H215)	Data cannot be written to the buffer memory of a MELSEC iQ-R series module.

MELSECNET/H network module

Network configuration

The module can be used in PLC to PLC network, using the following network configurations.

- Single network system
- Multiple network system

Point

When a redundant system is configured with the MELSEC-Q series Redundant CPU (QnPRHCPU) on the PLC to PLC network, the MELSECNET/H network module which is controlled by the RnCPU or Safety CPU can be used as a normal station only. In addition, the QJ71NT11B cannot be used in a redundant system.

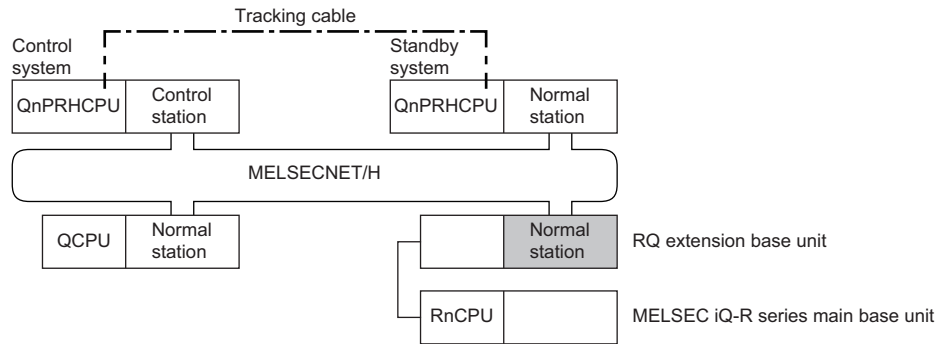

Function difference

- The module cannot be used in the simple dual-structured system.
- Set parameters for the MELSECNET/H network module mounted on the RQ extension base unit because the MELSECNET/H network module does not have default parameter settings under no parameter setting.
- The transient transmission cannot be performed at CPU module error. Therefore, the description of the error of the corresponding station cannot be checked from other stations. Check the error description by connecting an engineering tool to the CPU module where the error has occurred.
- The interlink data transfer function cannot be used. Use a link refresh and a program instead. The following figures show the example of the interlink transmission where data are transferred from network No.2 to network No.1.

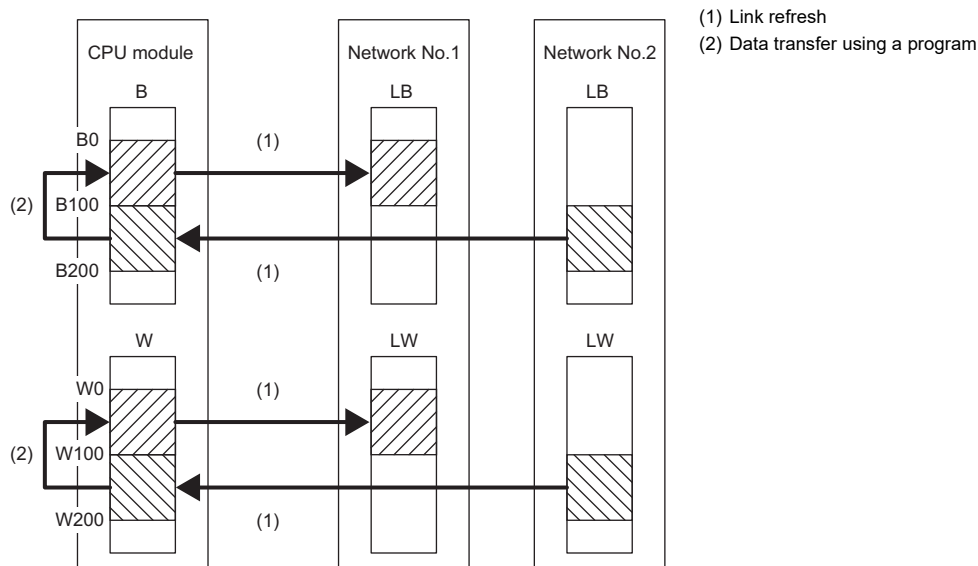

(0)	SM400		BMOV	K4B100	K4B0	H10
			BMOV	W100	W0	H100

■Engineering tool

- The version of an engineering tool that supports the MELSECNET/H network module is restricted. (📖 MELSEC iQ-R CPU Module User's Manual (Application))
- When the module occupying two slots (QJ71LP21S-25) is mounted, it is displayed on an engineering tool as occupying one slot. Therefore, when setting the module on "Module Configuration", mount the blank cover module (QG60) on the left side of the QJ71LP21S-25 mounted slot to secure an empty space of one slot (16 points). Then, set the empty space of one slot (16 points) in "I/O Assignment Setting" in the [I/O Assignment] tab on the "System Parameter" window.

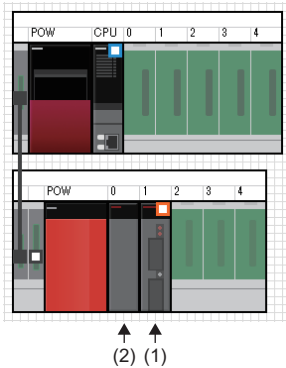

- (1) QJ71LP21S-25 (module occupying two slots)
- (2) QG60 (blank cover module)

- Data communications from the engineering tool (GX Works3) to other stations (stations where the engineering tool is not connected) cannot be performed via MELSECNET/H.
- On the system monitor and MELSECNET diagnostics of the engineering tool (GX Works3), the mode of the MELSECNET/H network module is always displayed as "Online".
- None of T, C, and ST can be specified for the device set in the link refresh settings. Specify another device.
- There are precautions for MELSECNET diagnostics of the engineering tool (GX Works3) via following devices.

Device	Precaution
CC-Link IE Controller Network interface board	Use the SW1DNC-MNETG-B with version 1.22Y or later and the ROM with version 2T or later.
CC-Link IE Field Network interface board	Use the SW1DNC-CCIEF-B with version 1.10L or later.
GOT	MELSECNET diagnostics cannot be used if the engineering tool (GX Works3) is connected to the programmable controller using the FA transparent function of GOT (in a CC-Link IE Controller Network or a CC-Link IE Field Network connection).

■GX Works2 and GX Developer

- From GX Works2 connected to a MELSEC iQ-R series CPU module, access to a MELSEC-Q series or MELSEC-L series CPU module is possible via the MELSECNET/H network module mounted on the RQ extension base unit. For the access via a MELSEC iQ-R series CPU module, use GX Works2 with the version of 1.519R or later.
- For data access from GX Works2 to other stations via a MELSEC iQ-R series CPU module, a remote password, if it is set, cannot be canceled from GX Works2. Cancel the password using the engineering tool that supports a MELSEC iQ-R series CPU module.
- From GX Developer, access to other stations via a MELSEC iQ-R series CPU module is not possible.

■Program

- Although the dedicated instructions of MELSECNET/H can be used for programming, for some dedicated instructions, use the string specification ("") when setting the start devices of the target station.

○: Available

Instruction name	Availability	Remarks
JP.READ, GP.READ	○	Only the string specification can be used for (s2).
JP.SREAD, GP.SREAD	○	Only the string specification can be used for (s2) and (d3).
JP.WRITE, GP.WRITE	○	Only the string specification can be used for (d1).
JP.SWRITE, GP.SWRITE	○	Only the string specification can be used for (d1) and (d3).
JP.SEND, GP.SEND	○	—
JP.RECV, GP.RECV	○	—
G.RECVS, Z.RECVS	○	—
J(P).ZNRD	○	Only the string specification can be used for (s2).
J(P).ZNWR	○	Only the string specification can be used for (d1).
J(P).REQ, G(P).REQ	○	—
Z(P).RRUN	○	—
Z(P).RSTOP	○	—
Z(P).RTMRD	○	—
Z(P).RTMWR	○	—

- No.254 (valid module during other station access) cannot be used to specify the network number of the dedicated instructions. Specify the network number within the range of 1 to 239.
- From the personal computer connected to the MELSECNET/H interface board, access to a programmable controller using md functions is possible.

Modules which can be mounted with the remote head module

Restrictions and precautions of when the MELSEC-Q series modules are used with the remote head module are same as those of when the modules are used as the MELSECNET/H remote I/O station. For the restrictions and precautions, refer to the manual of each module.

A

Appendix 7 EMC and Low Voltage Directives

In each country, laws and regulations concerning electromagnetic compatibility (EMC) and electrical safety are enacted. For the products sold in the European countries, compliance with the EU's EMC Directive has been a legal obligation as EMC regulation since 1996, as well as the EU's Low Voltage Directive as electrical safety regulation since 1997.

Manufacturers who recognize their products are compliant with the EMC and Low Voltage Directives are required to attach a "CE marking" on their products in European countries.

In some other countries and regions, manufacturers are required to make their products compliant with applicable laws or regulations and attach a certification mark on the products as well (such as UK Conformity Assessed (UKCA) marking in the UK, and Korea Certification (KC) marking in South Korea).

Each country works to make their regulatory requirements consistent across countries based on international standards. When the requirements are consistent, measures to comply with the EMC and electrical safety regulations become common across countries.

The UK and South Korea have enacted EMC regulations whose requirements are consistent with those of the EMC Directive. The UK has also enacted electrical safety regulations whose requirements are consistent with those of the Low Voltage Directive. In this section, the requirements of the EMC and Low Voltage Directives are described as examples of those of the EMC and electrical safety regulations.

Measures to comply with the EMC Directive

The EMC Directive sets requirements for emission (conducted and radiated electromagnetic interference emitted by a product) and immunity (the ability of a product not to be influenced by externally generated electromagnetic interference). This section describes the precautions for machinery constructed with the MELSEC iQ-R series modules to comply with the EMC Directive.

These precautions are based on the requirements of the EMC Directive and the harmonized standards. However, they do not guarantee that the entire machinery constructed according to the descriptions complies with the EMC Directive.

The manufacturer of the machinery must determine the testing method for compliance and declare conformity to the EMC Directive.

EMC Directive related standards

■ Emission requirements

Standard: EN61131-2:2007

Test item	Test description	Value specified in standard
CISPR16-2-3 Radiated emission ^{*2}	The electromagnetic wave emitted by the product to the external space is measured.	<ul style="list-style-type: none"> • 30 to 230MHz, QP: 40dBμV/m (measured at 10m distance)^{*1} • 230 to 1000MHz, QP: 47dBμV/m (measured at 10m distance)
CISPR16-2-1, CISPR16-1-2 Conducted emission ^{*2}	The noise level which the product emits to the power line is measured.	<ul style="list-style-type: none"> • 0.15 to 0.5MHz, QP: 79dB, Mean: 66dB^{*1} • 0.5 to 30MHz, QP: 73dB, Mean: 60dB

*1 QP: Quasi-Peak value, Mean: Average value

*2 Programmable controller is an open-type device and must be placed in a conductive control panel or similar type of enclosure. The tests were conducted with the programmable controller installed in a control panel, applying the maximum rated input voltage of the power supply module.

■ Immunity requirements

Standard: EN61131-2:2007

Test item	Test description	Value specified in standard
EN61000-4-2 Electrostatic discharge immunity ^{*1*2}	An electrostatic discharge is applied to the enclosure of the equipment.	<ul style="list-style-type: none"> • 8kV: Air discharge • 4kV: Contact discharge
EN61000-4-3 Radiated, radio-frequency, electromagnetic field immunity ^{*1}	An electric field is radiated to the product.	80% AM modulation @1kHz <ul style="list-style-type: none"> • 80 to 1000MHz: 10V/m • 1.4 to 2.0GHz: 3V/m • 2.0 to 2.7GHz: 1V/m
EN61000-4-4 Fast transient burst immunity ^{*1*2}	Burst noise is applied to power lines and signal lines.	<ul style="list-style-type: none"> • AC/DC power, I/O power, and AC I/O (unshielded) lines: 2kV • DC I/O, analog, and communication lines: 1kV
EN61000-4-5 Surge immunity ^{*1*3}	Lightning surge is applied to power lines and signal lines.	<ul style="list-style-type: none"> • AC power, AC I/O power, and AC I/O (unshielded) lines: 2kV CM, 1kV DM • DC power and DC I/O power lines: 0.5kV CM, 0.5kV DM • DC I/O, AC I/O (shielded), analog, and communication lines: 1kV CM
EN61000-4-6 Conducted RF immunity ^{*1}	High-frequency noise is applied to power lines and signal lines.	0.15 to 80MHz, 80% AM modulation @1kHz, 10Vrms
EN61000-4-8 Power-frequency magnetic field immunity ^{*1}	The product is immersed in the magnetic field of an induction coil.	50/60Hz, 30A/m
EN61000-4-11 Voltage dips and interruptions immunity ^{*1}	Power voltage is momentarily interrupted.	<ul style="list-style-type: none"> • 0%, 0.5 periods, starting at zero-crossing • 0%, 250/300 periods (50/60Hz) • 40%, 10/12 periods (50/60Hz) • 70%, 25/30 periods (50/60Hz)

*1 Programmable controller is an open-type device and must be placed in a conductive control panel or similar type of enclosure. The tests were conducted with the programmable controller installed in a control panel, applying the maximum rated input voltage of the power supply module.

*2 The accuracy of an analog-digital converter module, digital-analog converter module, temperature input module, and temperature control module may temporarily vary within $\pm 6\%$.

*3 The accuracy of an analog-digital converter module, digital-analog converter module, temperature input module, and temperature control module may temporarily vary as follows.

· Analog cable: \pm Within 10%

· Other cables (such as AC power supply cables): \pm Within 6%

Installation in a control panel

Programmable controller is an open-type device intended to be placed in a conductive control panel or similar type of enclosure.

Remote modules on each network must be also installed inside the control panel. Waterproof type remote modules can be installed outside the control panel.

This ensures safety as well as effective shielding of electromagnetic noise emitted from the programmable controller.

■Control panel

- Use a conductive control panel.
- Mask off an area used for grounding when securing the top or bottom plate to the control panel using bolts.
- To ensure electrical contact between inner plates and the control panel, mask off the bolt installation areas of each inner plate so that conductivity can be ensured in the largest area.
- Ground the control panel with a thick ground cable so that low impedance can be ensured even at high frequencies.
- Keep the diameter of the holes on the control panel to 10cm or less. If the diameter is larger than 10cm, electromagnetic wave may leak. In addition, because electromagnetic wave leaks through a clearance between the control panel and its door, reduce the clearance as much as possible. Use of EMI gaskets (sealing the clearance) can suppress undesired radiated emissions.

The tests were conducted by Mitsubishi Electric Corporation using a control panel having damping characteristics of 37dB (maximum) and 30dB (average) (measured at 3m distance, 30 to 300MHz).

■Power cable and ground cable

- Provide a ground point to the control panel near the power supply module. Ground the LG and FG terminals of the power supply module to the ground point with the shortest and thickest ground cable possible (30cm or shorter, 2mm²).
- Twist the ground cable extended from the ground point with the power cable so that larger amount of noise generated from the power cable is absorbed to the ground. Note that if a noise filter is attached to the power cable, twisting may not be required.

■DIN rails

Aluminum DIN rails may have insulation films. If an electrical contact cannot be secured between a DIN rail and a programmable controller, take measures to obtain conductivity. The following methods can be used to obtain conductivity.

- Screw the programmable controller to the control panel directly, without using a DIN rail.
- Use iron DIN rails, such as TH35-7.5Fe and TH35-15Fe.

■Extension cables

- Wire cables with extension cables placed in ducts. If not, dangling cable may swing or inadvertently be pulled, resulting in damage to the module or cables or malfunction due to poor contact.
- Do not clamp the extension cables with the jacket stripped.
- Use the shortest extension cable according to the distance between the base units connected.

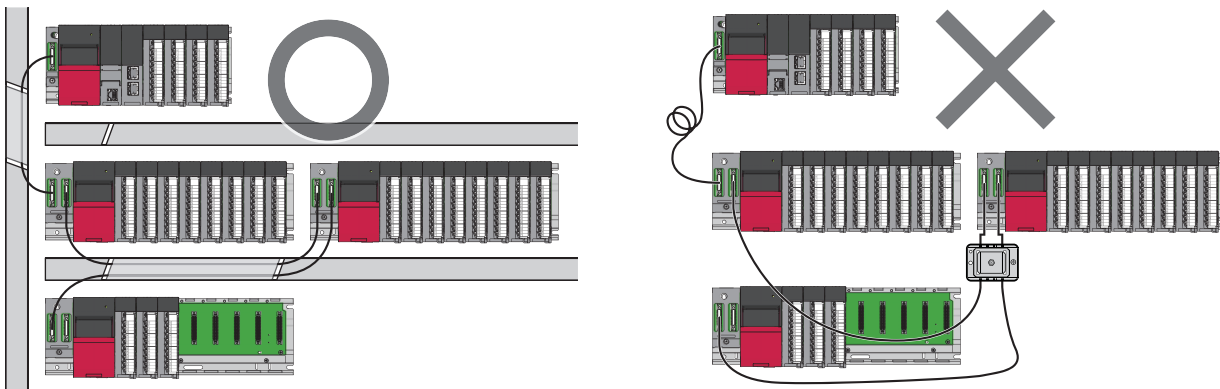

■ Noise filter (power supply line filter)

A noise filter is effective for reducing conducted noise in the 10MHz or less frequency band. (Use of a noise filter can suppress noise.)

The following are the installation precautions.

- Do not bundle the cables on the input side and output side of the noise filter. If bundled, the noise on the output side is induced into the filtered cable on the input side.

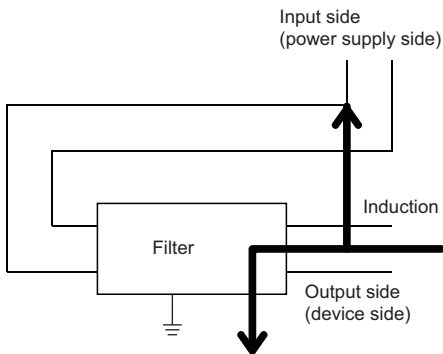

- Problematic example
Noise is induced when the input and output cables are bundled.

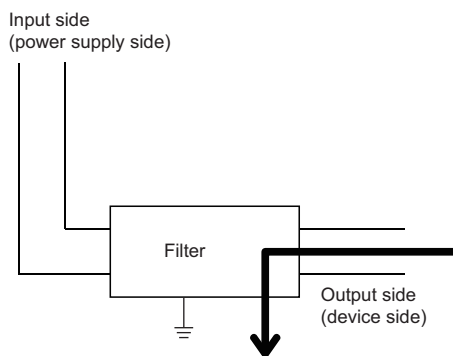

- Modification example
Install the input and output cables separately.

- Ground the ground terminal of the noise filter to the ground point of the control panel with the shortest cable possible (approximately 10cm).

■ Isolation transformer

An Isolation transformer is effective for reducing conducted noise (especially, lightning surge). Lightning surge may cause malfunction of the programmable controller. As measures against lightning surge, connect an isolation transformer as shown below. Use of an isolation transformer can reduce a lightning effect.

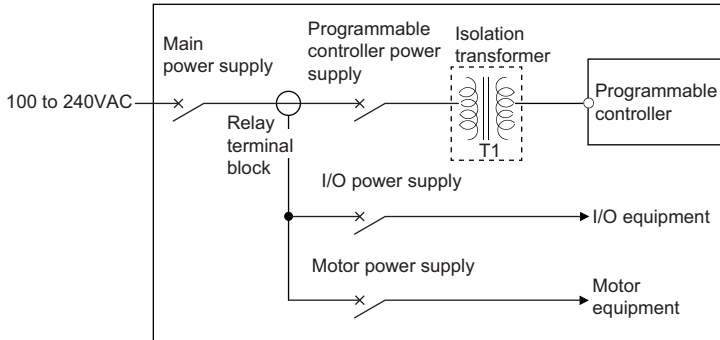

Use the isolation transformer according to its usage environment and storage environment. The following table lists the performance specifications of the recommended isolation transformer.

Item	Specifications
Number of phase	Single phase
Frequency	50/60Hz
Rated capacity	*1
Secondary voltage*2	200V/100V
Rating	Continuous
Heat resistance class (insulation class)	H
Electrostatic shield	Provided
Isolation resistance and withstand voltage*3	4200V/1 minute, 5MΩ or more between P and S
	2500V/1 minute, 7MΩ or more between P and iron core
	2500V/1 minute, 7MΩ or more between S and iron core
Standard*4	UL 506, UL 5085
	EN 61558-1
	EN 61558-2-4

*1 Select an isolation transformer considering the power capacity of equipment to be used.

*2 Select the secondary voltage so that the input voltage specifications of the power supply module are met.

*3 Among required voltage values specified in UL and EN standards, stricter values are listed here.

*4 Use an isolation transformer in the conditions that satisfy the requirements of standards.

Cables extended out of the control panel

Use a shielded cable for a cable extended out of the control panel such as an I/O signal line (including a common line) and cable for communications.

If a shielded cable is not used or not grounded properly, the noise immunity will not meet the requirement.

■Grounding a shielded cable

- Ground the shield of a shielded cable as close to the module as possible so that the grounded cable will not be affected by electromagnetic induction from ungrounded cables.
- Ground the exposed shield to a large area on the control panel. A clamp can be used as shown below. In this case, mask off the inner wall surface of the control panel, which comes in contact with the clamp.

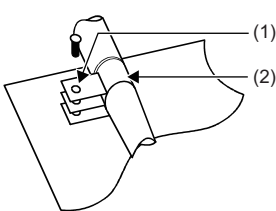

- (1) Paint mask
- (2) Clamp

Point

Do not use the tip of a PVC wire soldered onto a shield of the shielded cable for grounding. Doing so will raise the high-frequency impedance, resulting in loss of the shielding effect.

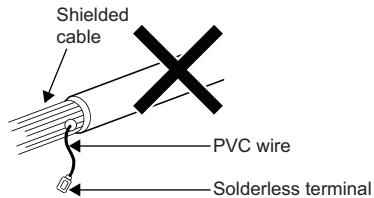

■Grounding cables with a cable clamp

Use shielded cables for external wiring and ground the shields of the shielded cables to the control panel with an AD75CK cable clamp (manufactured by Mitsubishi Electric). Ground the shields within 20 to 30cm from the module.

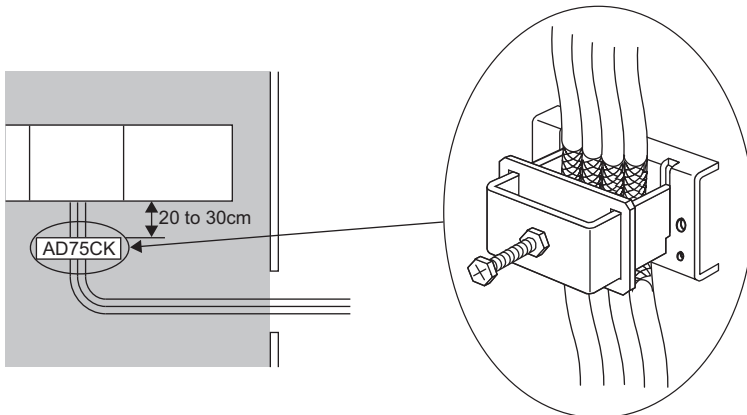

For details on the AD75CK, refer to the following.

📖 AD75CK-type Cable Clamping Instruction Manual

A

■ Ferrite core

A ferrite core is effective for reducing radiated noise in the 30MHz to 100MHz frequency band.

It is recommended to install a ferrite core if a shield cable extended out of the control panel does not provide sufficient shielding effects.

Install a ferrite core to the cable in the position just before the cable is extended out of the control panel. If the installation position is not appropriate, the ferrite core will not produce any effect.

Install a ferrite core to each power cable as shown below.

- Ferrite core used for the tests conducted by Mitsubishi Electric: ESD-SR-250 (manufactured by TOKIN Corporation), ZCAT3035-1330 (manufactured by TDK Corporation)

Ex.

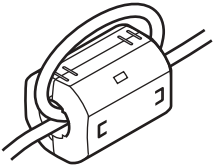

Connectors for external devices

When a module that requires a connector for external devices is used, take the following noise reduction measures.

- When shielded cables are connected

The following figure shows an example of wiring against noise when a connector (A6CON1) is used.

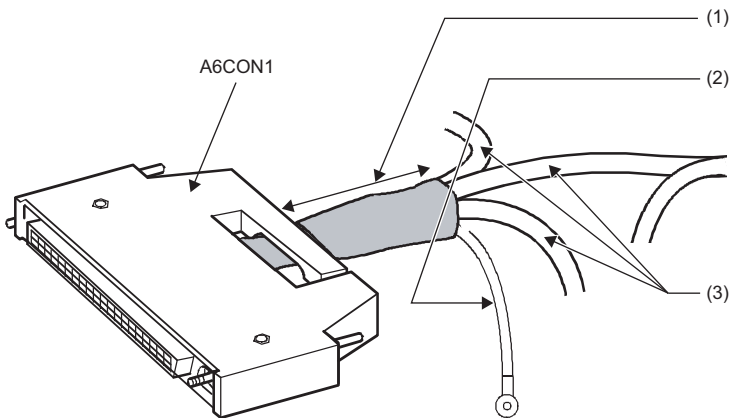

- (1) The length between the connector and the shielded cables should be the shortest possible.
- (2) Ground the FG wire of 2mm² or more as short as possible. Ground it to the control panel on the module side.
- (3) Shielded cable

- When shielded cables are processed

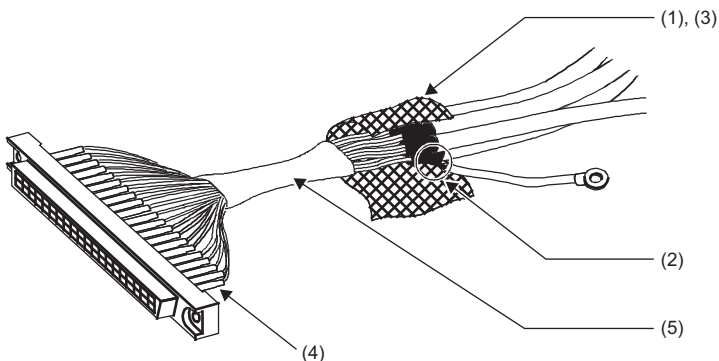

- (1) Strip the jacket of each shield of the cables.
- (2) Solder the shield of any shielded cable to the FG wire.
- (3) Bundle the shields with conductive tape.
- (4) To protect the wires, cover the connector pins with heat shrinkable insulating tubes. Exposed wires may cause malfunction of the module due to static electricity.
- (5) Cover the conductive part with insulating tape.

• When a duct is used (problematic example and modification example)

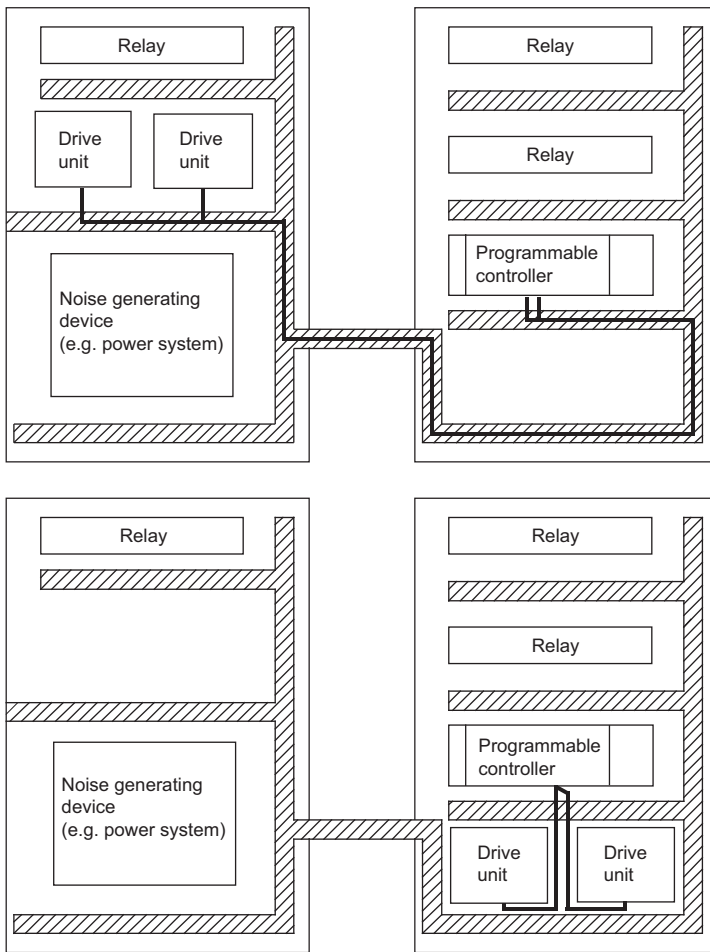

Shaded part: Wiring duct

• Problematic example

The drive units are placed near the noise source. The connection cables between the programmable controller and drive units are too long.

• Modification example

The programmable controller and drive units are placed closely. The connected cables between them are placed separately from the power line and the shortest. (In this example, the cables are connected without using the duct.)



External power supply

Use a reinforced or double insulated CE-marked external power supply, and ground the FG terminal. Ground the FG terminals.

- External power supply used for the tests conducted by Mitsubishi Electric: PS5R-SF24 (manufactured by IDEC Corporation)

Each module

■Power supply module

- Ground the LG and FG terminals after short-circuiting them.
- Keep the power cable length for the external power supply to 30m or less.

■CPU module

When inserted into a compatible module, the SD memory card (NZ1MEM-□GBSD) manufactured by Mitsubishi Electric already conforms to EN 61131-2.

■I/O modules

- Install a DC power supply and an I/O module inside the same control panel.
- Keep each DC power cable length to 30m or less.
- Take a surge protective measure, such as installing a surge suppressor, if the relay switches five times or more per minute.

■Channel isolated analog-digital converter modules, channel isolated digital-analog converter modules, channel isolated thermocouple input modules, channel isolated RTD input modules, and channel isolated analog-digital converter module (with signal conditioning function)

Making a relevant module comply with the EMC and Low Voltage Directives requires the wiring as shown below:

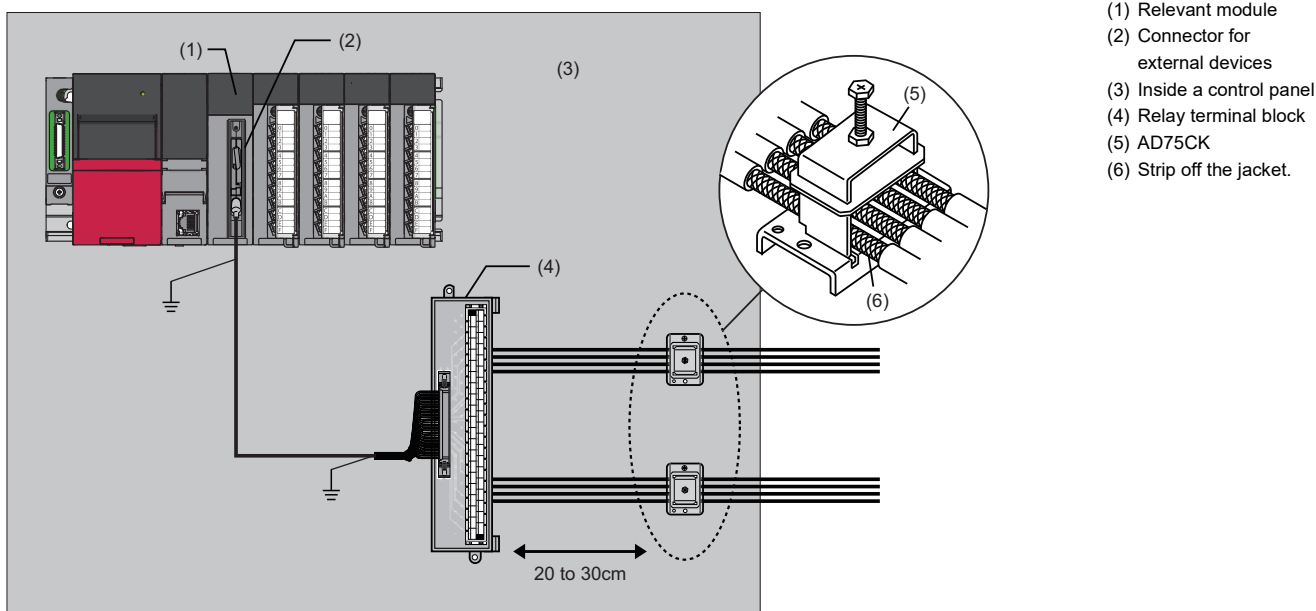

- The AD75CK cable clamp (manufactured by Mitsubishi Electric) allows up to four cables to be grounded together if the outside diameter is approximately $\Phi 7\text{mm}$.
- For the wiring between the connector for external devices and the relay terminal block, use a shielded cable and ground it to the control panel. In addition, the wire length should be 3m or less.

■HART-enabled analog-digital converter module

- Install a DC power supply and a HART-enabled analog-digital converter module inside the same control panel.
- Keep each DC power cable length to 30m or less.

■High-speed counter module, channel isolated pulse input module

- Install a DC power supply and a high-speed counter module inside the same control panel.
- Keep each DC power cable length to 30m or less.
- Keep the length of cables connected to external devices to 30m or less.

Flexible high-speed I/O control modules

- Install a ferrite core to the DC power cables connected to the flexible high-speed I/O control module and the DC power cables connected to the controller. The ferrite core, ESD-SR-250, manufactured by TOKIN Corporation is recommended.
- Install a DC power supply and a flexible high-speed I/O control module inside the same control panel.
- Use a shielded cable as the DC power cable when it is extended out of the control panel.
- Keep the length of the cables between the output section and the external devices to 2m or less for open collector output or 10m or less for differential output.
- Keep the length of the cables between the input section and the external devices to 30m or less.

Channel isolated analog-digital converter module (SIL2 mode)

- Do not ground the shielded cable between the RY40PT5B of the module set and the terminal module.
- Use a same external power supply for the R60DA8-G and the RY40PT5B of the module set.
- For the external power supply of relays, attach a ferrite core with the damping characteristics equivalent to that of the ESD-SR-250 (manufactured by TOKIN Corporation). Wrap the cable around the ferrite core by one or more.
- Install a DC power supply and a channel isolated analog-digital converter module (SIL2 mode) inside the same control panel.
- Keep each DC power cable length to 30m or less.

Channel isolated digital-analog converter module (SIL2 mode)

- Do not ground the shielded cable between the RY40PT5B-AS of the module set and the terminal module.
- Use a same external power supply for the R60DA8-G and the RY40PT5B-AS of the module set.
- For the external power supply of the R60DA8-G set to SIL2 mode, attach a ferrite core with the damping characteristics equivalent to that of the ESD-SR-250 (manufactured by TOKIN Corporation). Wrap the cable around the ferrite core by two or more.
- For the external power supply of relays, attach a ferrite core with the damping characteristics equivalent to that of the ESD-SR-250 (manufactured by TOKIN Corporation). Wrap the cable around the ferrite core by one or more.
- Install a DC power supply and a channel isolated digital-analog converter module (SIL2 mode) inside the same control panel.
- Keep each DC power cable length to 30m or less.

Positioning modules

- Install a DC power supply and a positioning module inside the same control panel.
- Keep the length of a cable between the RD75 and a drive unit as follows.
 - RD75P□: 2m or less
 - RD75D□: 10m or less
- Keep the length of cables connected to external devices to 30m or less except the pulse output.
- Keep each DC power cable length to 30m or less.

Simple Motion modules

- Install a DC power supply and a Simple Motion module inside the same control panel.
- Keep the length of cables connected to external devices to 30m or less (10m or less for open collector output type).
- In wiring inside the panel, the power line connected to the power or servo amplifier and the communication cable such as an expansion cable or a network cable must not be mixed. In the duct, leave 10cm (3.94inch) or more between the power line and the communication cable, and separate using a separator (made of metal), etc. It is required in the same control panel as well.
- Mixing the power line and communication cable may cause increase of noise or malfunction due to noise influence.

CPU module, Ethernet interface module with built-in CC-Link IE (when using the Ethernet function), EtherNet/IP network interface module, RJ71GN11-EIP (EtherNet/IP part)

- Use a shielded twisted pair cable for connection to the 10BASE-T, 100BASE-TX, or 1000BASE-T connector. Strip a part of the jacket of the shielded twisted pair cable as shown below and ground the exposed shield to the largest area.

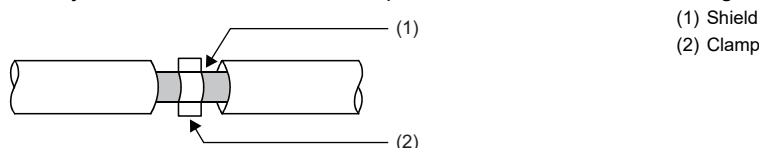

■CC-Link IE TSN master/local module, CC-Link IE Field Network master/local modules, Ethernet interface modules with built-in CC-Link IE (when using the CC-Link IE function), CC-Link IE Field Network-compatible Simple Motion modules, and remote head module

- Use an Ethernet cable recommended by CC-Link Partner Association.
- Ethernet cable is a shielded cable. Strip a part of the jacket as shown below and ground the exposed shield to the largest area.

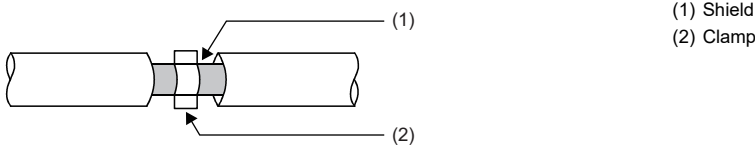

■CC-Link system master/local module

- Ground the shield of a cable connected to the CC-Link system master/local module or any of the CC-Link stations which is the farthest from the input power inside the control panel within 30cm from the module or station.
- Ver.1.10-compatible CC-Link dedicated cable is a shielded cable Strip a part of the jacket of the cable as shown below and ground the exposed shield to the largest area.

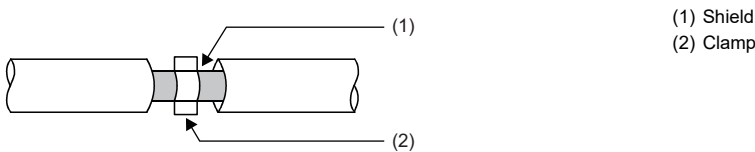

- Use the specified Ver.1.10-compatible CC-Link dedicated cable.
- Use the FG terminals of the CC-Link system master/local module and CC-Link stations as shown below to connect to the FG line inside the control panel.

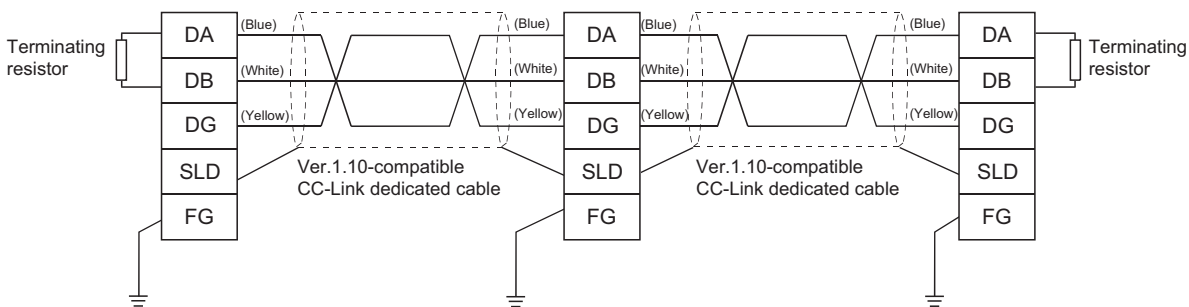

- Use a CE-marked power supply to which the module power supply or external power supply is connected. Ground the FG terminals.
- Keep each power cable connected to the external power supply terminal or module power supply terminal to 30m or less.
- Connect a noise filter to the external power supply. Use a noise filter with the damping characteristic, MA1206 (manufactured by TDK-Lambda Corporation) or equivalent. Note that a noise filter is not required if the module is used in Zone A defined in EN 61131-2.

Manufacturer	Contact
TDK-Lambda Corporation	www.tdk-lambda.com

- Keep the length of signal cables connected to the analog input terminals of the AJ65BT-64RD3, AJ65BT-64RD4, and AJ65BT-68TD to 30m or less. Wire cables connected to the external power supply and module power supply terminal in the control panel where the module is installed.
- For the cable connected to the power supply terminal or the AJ65SBT-RPS, AJ65SBT-RPG, or AJ65BT-68TD, install a ferrite core with the damping characteristics, ZCAT3035-1330 (manufactured by TDK Corporation) or equivalent. Wrap the cable around the ferrite core by one as shown below.

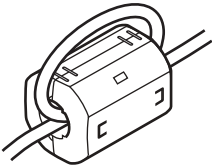

Manufacturer	Contact
TDK Corporation	www.global.tdk.com

- To supply power to the module power supply terminal of the remote I/O module using the AC/DC power supply, perform the following preparations.
 - Install the AC/DC power supply in the control panel where the module is installed.
 - Use a reinforced or double insulated CE-marked AC/DC power supply, and ground the FG terminal. (AC/DC power supplies used for the tests conducted by Mitsubishi Electric: DLP-120-24-1, DRJ240-24-1 (manufactured by TDK-Lambda Corporation), PS5R-VF, PS6R-F24 (manufactured by IDEC Corporation))
 - For the cable connected to the AC input terminal and DC output terminals of the AC/DC power supply, attach a ferrite core. Wrap the cable around the ferrite core by one as shown below. (Ferrite core used for the tests conducted by Mitsubishi: ESD-SR-250 manufactured by TOKIN Corporation)

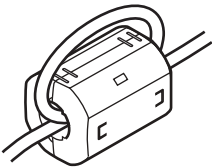

- To supply power to the module power supply terminals of the AJ65SBT-64AD/62DA, AJ65SBT2B-64AD/DA/TD/RD3, or AJ65VBTUCU-68ADVN/ADIN/DAVN using the AC/DC power supply, perform the following preparations.
 - Install the AC/DC power supply in the control panel where the module is installed.
 - Use a CE-marked AC/DC power supply, and ground the FG terminal. (AC/DC power supplies used for the tests conducted by Mitsubishi Electric: DLP-120-24-1, DRJ240-24-1, DRJ100-24-1 (manufactured by TDK-Lambda Corporation))
- To supply power to the module power supply terminals of the AJ65SBT2B-64AD using the AC/DC power supply, perform the following preparations.
 - For the cable connected to the DC output terminals of the AC/DC power supply, attach ferrite cores to the following locations.
 - Near the DC output terminals of the AC/DC power supply
 - Near the power input terminals of the AJ65SBT2B-64AD
 - Wrap the cable around the ferrite core once as shown below. (Ferrite core used for the tests conducted by Mitsubishi Electric: ESD-SR-250 (manufactured by TOKIN Corporation))

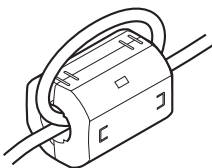

- To supply power to the module power supply terminals of the AJ65SBT2B-64DA/RD3 using the AC/DC power supply, perform the following preparations.
 - For the cable connected to the DC output terminals of the AC/DC power supply, attach ferrite cores to the following locations.
 - Near the DC output terminals of the AC/DC power supply
 - Near the power input terminals of the AJ65SBT2B-64DA/RD3
 - Wrap the cable around the ferrite core once as shown below. (Ferrite core used for the tests conducted by Mitsubishi Electric: ZCAT3035-1330 (manufactured by TDK Corporation))

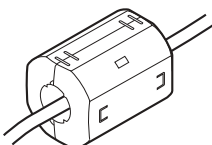

- To supply power to the module power supply terminals of the AJ65SBT2B-64TD using the AC/DC power supply, perform the following preparations.
- For the cable connected to the AC input terminal and DC output terminals of the AC/DC power supply, attach ferrite cores to the following locations. Wrap the cable around the ferrite core as shown below.
 - Near the AC input terminal of the AC/DC power supply: Thread the cable through the ferrite core.
 - Near the power input terminal of the AJ65SBT2B-64TD: Wrap the cable around the ferrite core once.

(Ferrite cores used for the tests conducted by Mitsubishi Electric: ZCAT3035-1330 (manufactured by TDK Corporation), RFC-8 (manufactured by KITAGAWA INDUSTRIES CO., LTD))

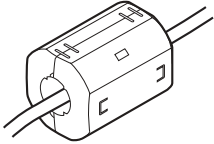

Threading the cable through the ferrite core

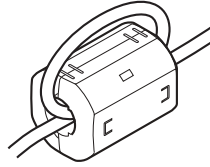

Wrapping the cable around the ferrite core once

■GP-IB interface module

Attach ferrite cores to the connector bases on the both ends of GPIB cable. Use the ferrite core equivalent to ZCAT3035-1330 manufactured by TDK Corporation. Use the ferrite core with the cable threaded through it.

Manufacturer	Contact
TDK Corporation	www.global.tdk.com

■AnyWireASLINK master module

- For the grounding of the RJ51AW12AL and routing of the power supply cable, provide a ground point to the control panel near the power supply module. Then, ground the LG terminals of the transmission cable terminal block to the ground point with the thickest and shortest ground cable possible (2mm² or less, a length of 30cm or shorter).
- For the cable connected to the transmission cable terminal block, install a ferrite core with the damping characteristics, the ZCAT3035-1330 (manufactured by TDK Corporation) or equivalent, within 20cm from the transmission cable terminal block of this product. Wrap the cable around the ferrite core by one as shown below.

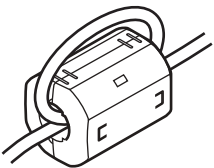

Manufacturer	Contact
TDK Corporation	www.global.tdk.com

- Use a CE-marked power supply to which the module power supply or external power supply is connected. Ground the FG terminals.
- Keep each power cable connected to the external power supply terminal or module power supply terminal to 30m or less.
- Use the RJ51AW12AL in the zone B. ^{*1}

^{*1} Zone defines categories according to industrial environment, specified in the EMC and Low Voltage Directives, EN61131-2.

- Zone C: Factory main power supplies (isolated from public power supplies by dedicated transformers)
- Zone B: Dedicated power distribution, secondary surge protection (Rated voltage: 300V or less)
- Zone A: Local power distribution, protected from dedicated power distribution by AC/DC converters and insulation transformers (Rated voltage: 120V or less)

■CANopen module

- Ground shields of CAN bus cables at the both ends of the network. When grounding the shields, check for the potential difference between the grounding points to secure the safety. Take a measure to prevent a damage if the potential difference is detected.

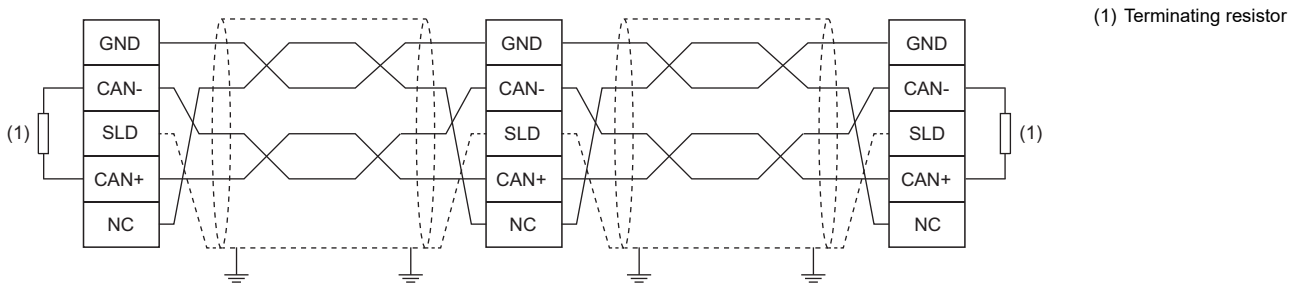

- CAN bus cable is a shielded cable. Strip a part of the jacket of the cable as shown below and ground the exposed shield to the area of 35mm or more.

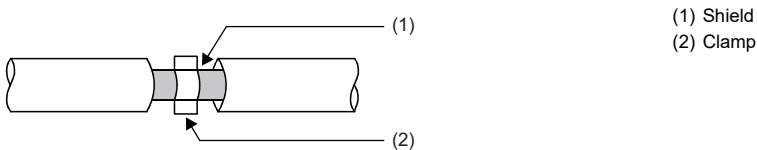

■Laser displacement sensor control module

- Connect a noise filter to the external power supply. Use a noise filter with the damping characteristic, RSEN-2006 (manufactured by TDK-Lambda Corporation) or equivalent.

Manufacturer	Contact
TDK-Lambda Corporation	www.tdk-lambda.com

- Use a DC power cable of 30m or shorter when connecting it to the external power supply terminal. When an external power supply and a programmable controller are installed in the same control panel, twist the DC power cable at the shortest distance and connect the external power supply cable to the module as short as possible. For the DC power cable, install a ferrite core with the damping characteristics equivalent to that of the E04SR200935A (manufactured by SEIWA ELECTRIC MFG. CO., LTD.). Wrap the cable around the ferrite core by one as shown below at this time.

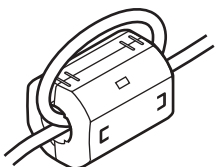

- When the DC power cable is extended for 5m or more or connected from outside the control panel of the programmable controller, use a shielded cable. Depending on the usage environment, strip a part of the jacket of the cable as shown below and ground the exposed shield to the largest area within a range of 30cm from the control module.

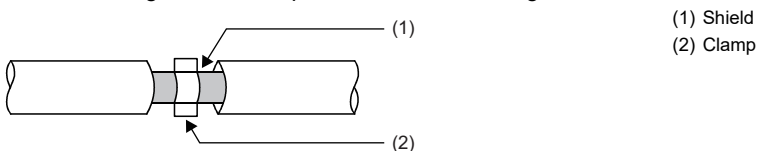

- An external power supply terminal is available for the cable within 2.0mm². Use the thickest cable as possible for grounding.
- Ground the shields of the sensor head cables to the control panel with an AD75CK cable clamp (manufactured by Mitsubishi Electric). Ground the shields within 20 to 30cm from the module. Ground shield materials with braided wires for grounding and cables to a cable clamp. (Shield material used for the tests conducted by Mitsubishi: Shielded tube (zipper type) SHNJ type manufactured by Zippertubing (Japan),Ltd.)

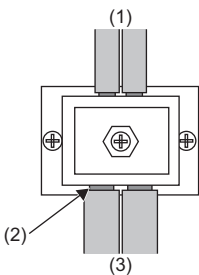

- (1) Connect the cable to the control module.
- (2) Braided wires for grounding
- (3) Connect the cable to outside control panel.

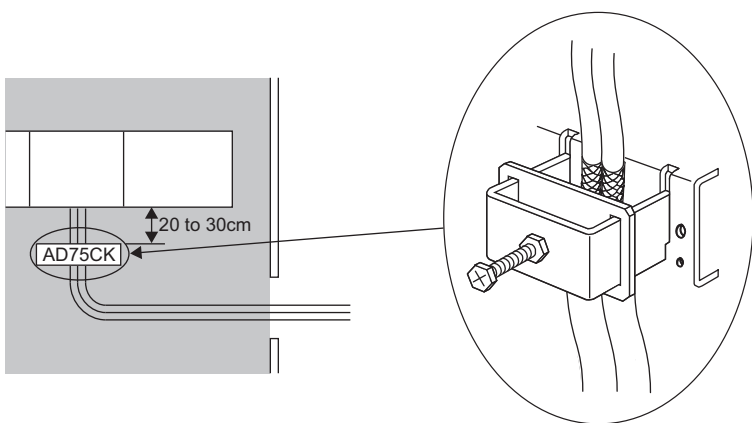

- A ferrite core for the sensor head cable is effective for reducing radiated noise in the 30MHz to 100MHz frequency band. It is recommended to install a ferrite core and shielded tube (zipper type) if a shield cable does not provide sufficient shielding effects. Install a ferrite core to the connection point where the cable of the sensor head. After installing the ferrite core, cover it with a shielded tube (zipper type). (Ferrite core used for the tests conducted by Mitsubishi: E04SR200935A manufactured by SEIWA ELECTRIC MFG. CO., LTD.)

- (1) Ferrite core

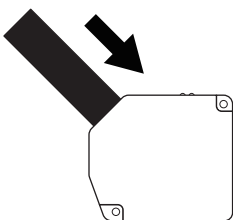
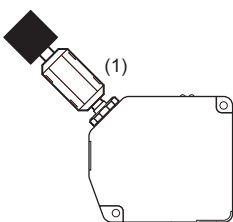

■ MELSECNET/H network module

- When using a coaxial cable for the RJ71BR11, make sure to use a double-shielded coaxial cable (5C-2V-CCY manufactured by Fujikura Ltd). Using the double-shielded coaxial cable reduces radiated noise in the frequency band of 30MHz or above. Ground the outer shield of the double-shielded coaxial cable.

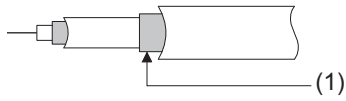

(1) Ground the outer shield of the cable.

Measures to comply with the Low Voltage Directive

The Low Voltage Directive requires electrical equipment that is designed or adapted for use between 50 to 1000VAC or 75 to 1500VDC to satisfy the safety requirements.

This section describes the precautions for use of the MELSEC iQ-R series modules to comply with the Low Voltage Directive. These precautions are based on the requirements of the Low Voltage Directive and the harmonized standards. However, they do not guarantee that the entire machinery constructed according to the descriptions complies with the Low Voltage Directive. The manufacturer of the machinery must determine the testing method for compliance and declare conformity to the Low Voltage Directive.

Standard applied to MELSEC iQ-R series modules

- EN61131-2 "Safety requirements for electrical equipment for measurement, control and laboratory use"

The MELSEC iQ-R series modules that operate at 50VAC/75VDC or higher rated input voltage have also been developed in accordance with EN61131-2.

However, the modules which operate at less than 50VAC/75VDC rated input voltage are not targeted for the Low Voltage Directive compliance.

MELSEC iQ-R series products to comply with the Low Voltage Directive

■ Power supply modules

Power supply modules for the AC power supply which operate at 100VAC or 200VAC rated input voltage have hazardous voltage (peak voltage higher than or equal to 42.4V) internally. Therefore, insulation between the primary and secondary circuits is reinforced for CE-marked power supply modules.

■ I/O modules

I/O modules which operate at 100VAC or 200VAC rated input/output voltages have hazardous voltage (peak voltage higher than or equal to 42.4V) internally. Therefore, insulation between the primary and secondary circuits is reinforced for CE-marked I/O modules.

I/O modules which operate at 24VDC or less rated input voltage are not targeted for the Low Voltage Directive compliance.

■ Base units, CPU modules, remote head modules, SD memory cards, extended SRAM cassettes, battery-less option cassettes, and intelligent function modules

These products are not targeted for the Low Voltage Directive compliance because the circuits in the products operate at the 24VDC or less rated voltage.

Power supply

Power supply modules are designed to meet the overvoltage category II. Confirm that the power supply to a programmable controller meets the overvoltage category II.

External wiring

■24VDC external power supply

For 24VDC I/O modules or intelligent function modules requiring an external power supply, connect an external power supply of which insulation between the 24VDC circuit section and the hazardous voltage circuit section is reinforced.

■External devices

For external devices connected to a programmable controller, use the one of which insulation between the interface circuit section to the programmable controller and the hazardous voltage circuit section is reinforced (if the device internally has a hazardous voltage circuit section).

■Reinforced insulation

Reinforced insulation means insulation having the following withstand voltage.

Rated voltage of hazardous voltage	Surge withstand voltage (1.2/50 μ s)
150VAC or less	2500V
300VAC or less	4000V

(Overvoltage category II, source: IEC 60664-1)

Appendix 8 Machinery Directive

Compliance with the Machinery Directive, which is one of the EU directives, has been mandatory for safety products sold within EU member states since 1995. For safety products sold within the UK, compliance with the Supply of Machinery (Safety) Regulations 2008, which is UK law, has become mandatory in 2021, because the UK left the EU. For Mitsubishi Electric safety programmable controllers, we declare that our products comply with applicable laws or regulations based on the certification by a third-party certification organization, TUV Rheinland, and attach the CE marking and the UK Conformity Assessed (UKCA) marking on them.

The sales representative in EU member states is:

Company: MITSUBISHI ELECTRIC EUROPE B.V.

Address: Mitsubishi-Electric-Platz 1, 40882 Ratingen, Germany

Note that, although the measures to comply with the Machinery Directive are described here, because requirements of the Machinery Directive are consistent with those of the Supply of Machinery (Safety) Regulations 2008, measures to comply with the directive and the regulations become common.

Measures to comply with the Machinery Directive

The Machinery Directive (2006/42/EC) requires that machinery satisfy the three pillars of safety: mechanical safety, electrical safety, and worker safety. The safety programmable controller complies with the Machinery Directive. Before using this product, please read this manual, the relevant manuals, and the safety standards carefully and pay full attention to safety to handle the product correctly. The descriptions are based on the requirements of the Machinery Directive and the harmonized standards. However, they do not guarantee that the entire machinery constructed according to the descriptions complies with the Machinery Directive. The manufacturer of the machinery must determine the testing method for compliance and declare conformity to the Machinery Directive.

Machinery Directive related standards

■ Immunity requirements

Standard: EN61326-3-1:2008

Test item	Test description	Value specified in standard
EN61000-4-2 Electrostatic discharge immunity* ¹	An electrostatic discharge is applied to the enclosure of the equipment.	<ul style="list-style-type: none"> • 8kV: Air discharge • 6kV: Contact discharge
EN61000-4-3 Radiated, radio-frequency, electromagnetic field immunity* ¹	An electric field is radiated to the product.	80% AM modulation @1kHz <ul style="list-style-type: none"> • 80 to 1000MHz: 20V/m • 1.4 to 2.0GHz: 10V/m • 2.0 to 2.7GHz: 3V/m
EN61000-4-4 Fast transient burst immunity* ¹	Burst noise is applied to power lines and signal lines.	<ul style="list-style-type: none"> • AC power: 3kV • DC power: 3kV • I/O: 2kV, Functional earth: 2kV
EN61000-4-5 Surge immunity* ¹	Lightning surge is applied to power lines and signal lines.	<ul style="list-style-type: none"> • AC power: 2kV CM, 4kV CM • DC power: 1kV CM, 2kV CM • I/O: 2kV CM
EN61000-4-6 Conducted RF immunity* ¹	High-frequency noise is applied to power lines and signal lines.	0.15 to 80MHz, 80% AM modulation @1kHz, 10Vrms
EN61000-4-8 Power-frequency magnetic field immunity* ¹	The product is immersed in the magnetic field of an induction coil.	50/60Hz, 30A/m
EN61000-4-11 Voltage dips and interruptions immunity* ¹	Power voltage is momentarily interrupted.	<ul style="list-style-type: none"> • 0%, 1 period • 0%, 250/300 periods (50/60Hz) • 40%, 10/12 periods (50/60Hz) • 70%, 25/30 periods (50/60Hz)
EN61000-4-29 Voltage dips and interruptions immunity* ¹	Power voltage is momentarily interrupted.	<ul style="list-style-type: none"> • 40% UT 10ms • 0% UT 20ms
EN61000-4-16 Immunity to conducted, common mode disturbances in the frequency range 0Hz to 150kHz* ¹	Low-frequency noise is applied to power lines and signal lines.	<ul style="list-style-type: none"> • AC power 1.5k to 15kHz: 1 to 10V, 20dB/decade 15k to 150kHz: 10V • DC power 1.5k to 15kHz: 1 to 10V, 20dB/decade 15k to 150kHz: 10V DC, 16 2/3Hz, 50Hz and 60Hz: 10V (continuous mode), 100V (short term mode (1s duration)) 150Hz and 180Hz: 10V (continuous mode) • I/O 1.5k to 15kHz: 1 to 10V, 20dB/decade 15k to 150kHz: 10V DC, 16 2/3Hz, 50/60Hz: 10V continuous, 100V for a short time (1s) 150Hz and 180Hz: 10V (continuous mode)

*1 Safety programmable controller is an open-type device intended to be placed in a conductive control panel or similar type of enclosure. The tests were conducted with the safety programmable controller installed in a control panel.

A

Appendix 9 General Safety Requirements

When a programmable controller is powered on or off, the control module may not output signals correctly for a moment due to differences in the delay and startup times between the power supply for the programmable controller and the external power supply (especially, DC power) for the control module.

Signals also may not be output correctly when the external power supply or the programmable controller fails.

In terms of fail-safe and to prevent any incorrect output signals from leading to the entire system failure, configure safety circuits (such as emergency stop circuits, protection circuits, and interlock circuits) external to the programmable controller for the parts where the incorrect output may cause damage to the machines or accidents.

This section shows system design circuit examples, considering the points described above.

When the C Controller module is used, refer to the following.

MELSEC iQ-R C Controller Module User's Manual

When using a MELSECWinCPU module, refer to the following.

MELSEC iQ-R MELSECWinCPU Module User's Manual

System design circuit examples

When the ERR contact of the power supply module is not used

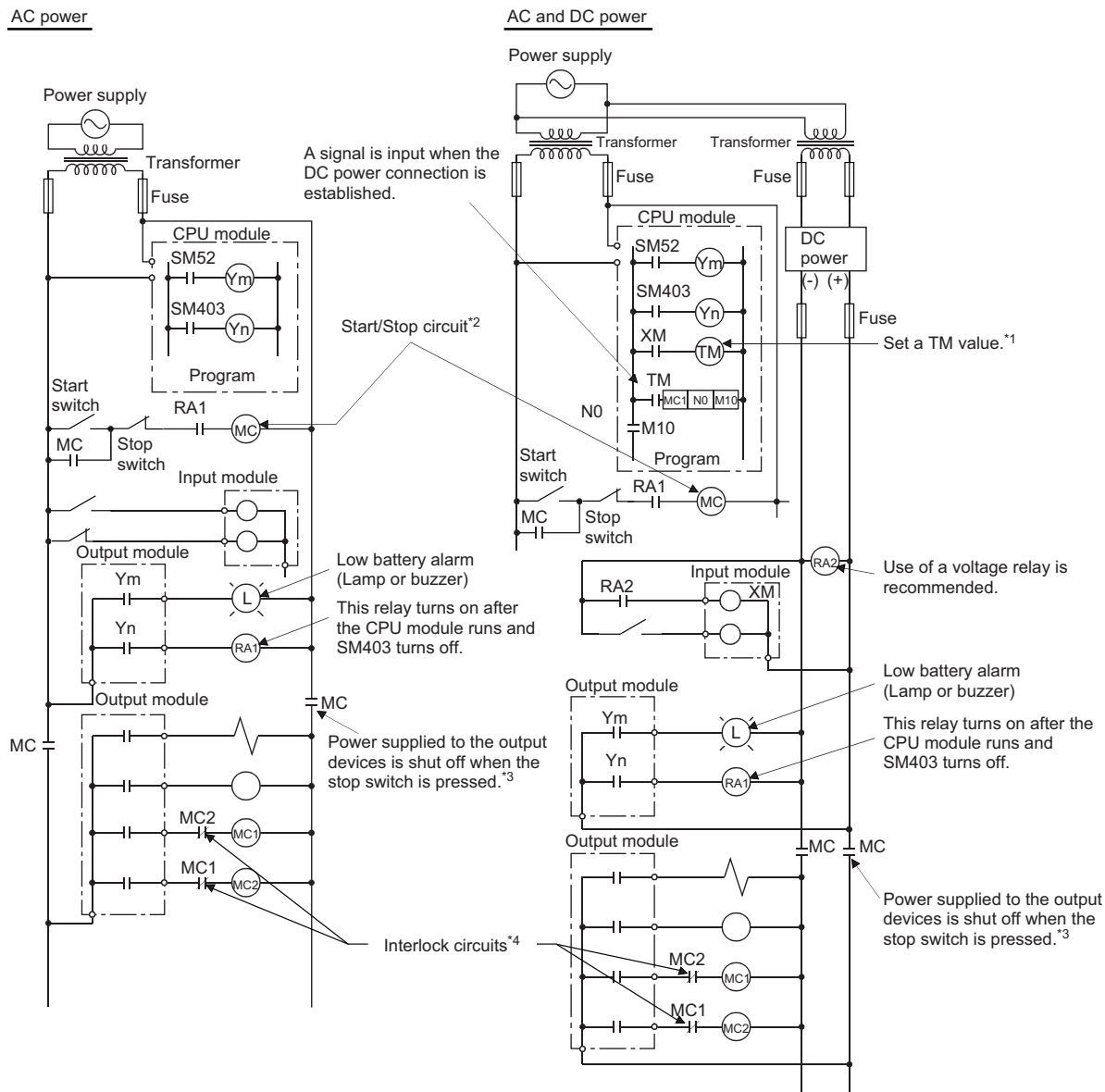

- *1 Set a time required for DC power supply to be established.
- *2 The programmable controller starts when RA1 (run monitor relay) turns on.
- *3 The stop switch means an emergency stop switch or a limit switch.
- *4 Configure external interlock circuits for conflicting operations such as forward/reverse rotations and the parts where the incorrect output may cause damage to the machines or accidents.

The power-on procedure is described below.

■**For AC power**

1. Power on the programmable controller.
2. Run the CPU module.
3. Turn on the start switch.
4. The output devices will be activated by the program when the relay, MC, turns on.

■**For AC and DC power**

1. Power on the programmable controller.
2. Run the CPU module.
3. The relay, RA2, turns on when AC power is converted to DC power.
4. The timer, TM, turns on when the DC power connection is fully established.
(The TM value shall be the time required from when RA2 turns on to when the DC power connection is fully established. Set this value to 0.5 seconds.)
5. Turn on the start switch.
6. The output devices will be activated by the program when the relay, MC, turns on.
(If a voltage relay is used for RA2, the timer, TM, is not required.)

When the ERR contact of the power supply module is used

AC and DC power

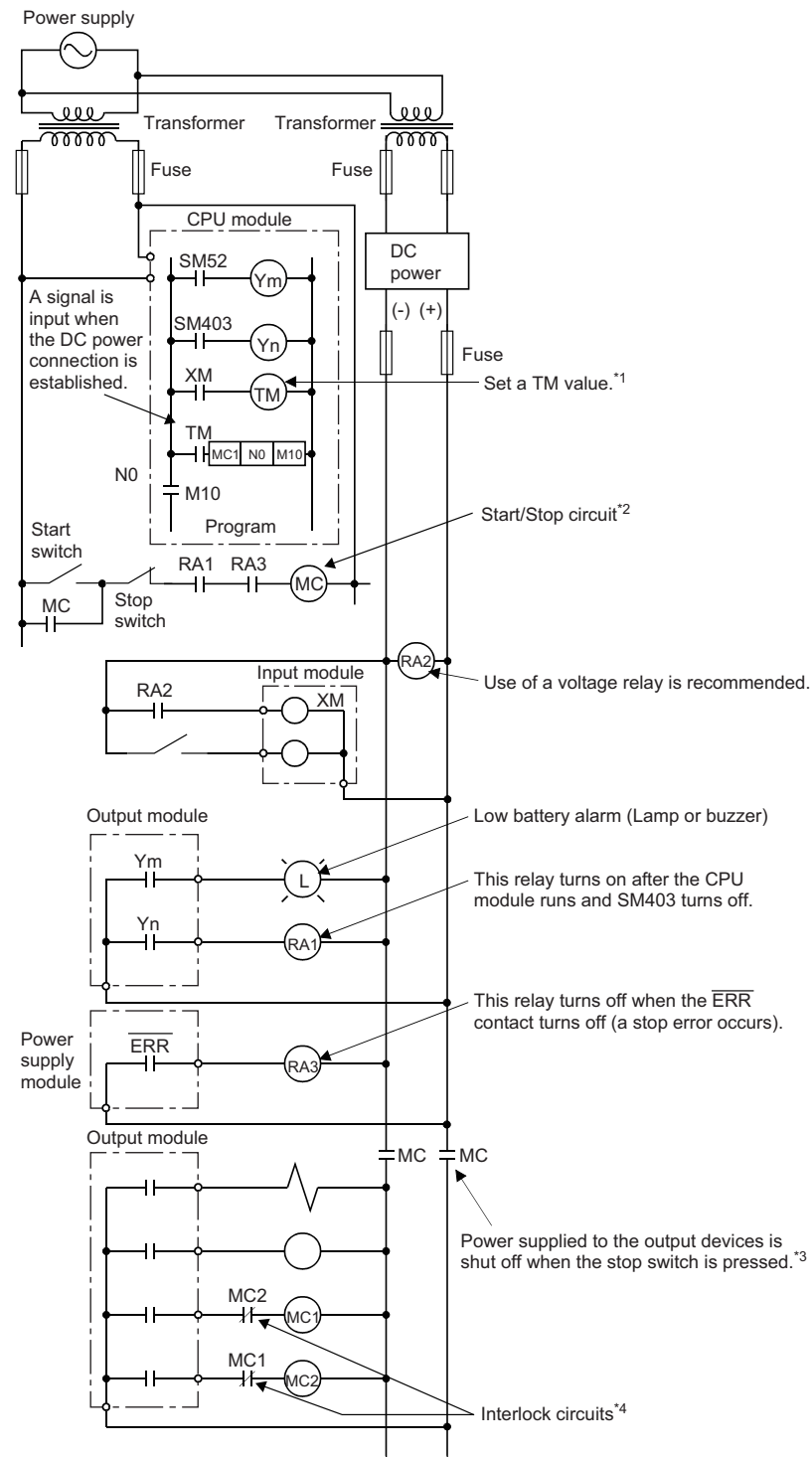

*1 Set a time required for DC power supply to be established.

*2 The programmable controller starts when RA1 (run monitor relay) turns on.

*3 The output devices are turned off at a stop caused by a stop switch (an emergency stop switch or a limit switch) or ERR contact OFF.

*4 Configure external interlock circuits for conflicting operations such as forward/reverse rotations and the parts where the incorrect output may cause damage to the machines or accidents.

The power-on procedure is described below.

■For AC and DC power

- 1.** Power on the programmable controller.
- 2.** Run the CPU module.
- 3.** The relay, RA2, turns on when AC power is converted to DC power.
- 4.** The timer, TM, turns on when the DC power connection is fully established.
(The TM value shall be the time required from when RA2 turns on to when the DC power connection is fully established. Set this value to 0.5 seconds.)
- 5.** Turn on the start switch.
- 6.** The output devices will be activated by the program when the relay, MC, turns on.
(If a voltage relay is used for RA2, the timer, TM, is not required.)

Fail-safe measures for programmable controller failure

A CPU module and a remote head module can detect hardware failures of themselves and their memory by the self-diagnostic function. However, failures which occur in a part, such as an I/O control part, may not be detected.

In this case, depending on the failure, all input or output points may turn on or off, or normal operation and safety of the control-target device may not be ensured.

Even though Mitsubishi programmable controllers are manufactured under strict quality control, they may fail due to some reasons. Provide fail-safe circuits external to the programmable controller so that no machine is damaged and no accident occurs.

A system example and its fail-safe circuit example are shown below.

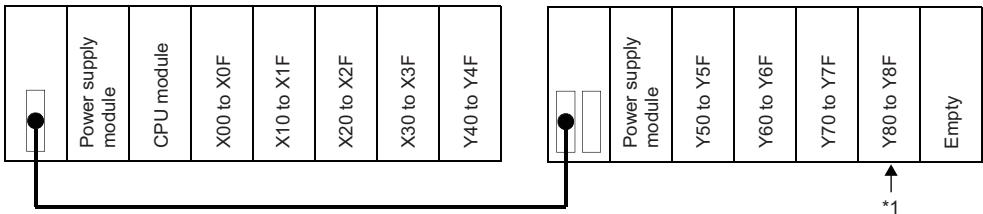

*1 Mount an output module for fail-safe purpose in the last slot of the system. In the example above, Y80 to Y8F are assigned to the output module.

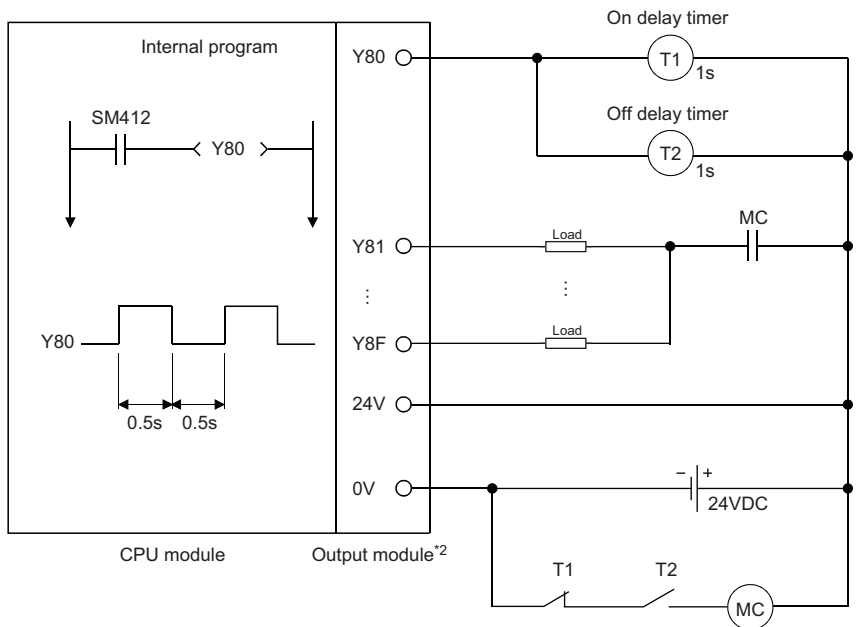

*2 Since Y80 turns on and off at 0.5 second intervals, use a contactless output module. (In the example above, a transistor output module is used.)



Appendix 10 Calculating Heating Value of Programmable Controller

The ambient temperature inside the control panel where a programmable controller is installed must be 55°C or less (for the extended temperature range base unit, 60°C or less).

It is necessary to know the average power consumption (heating value) of the equipment and devices installed inside the control panel when designing a heat release structure of the panel.

Calculate a rise in ambient temperature inside the control panel according to the following calculation formula.

The calculation formula for a rise in ambient temperature inside the control panel is as follows.

$$T = \frac{W}{UA} \text{ (}^\circ\text{C)}$$

W: Average power consumption of the entire programmable controller system (☞ Page 288 Calculation formula for the average power consumption)

A: Surface area inside the control panel (m²)

U: 6 when the ambient temperature inside the control panel is uniformed using a fan or 4 when the air inside the control panel is not circulated

Point

If the temperature inside the control panel is expected to exceed the specified range, it is recommended to install a heat exchanger to the panel to lower the temperature.

If a general-purpose fan is used, dust will be sucked into the control panel with the external air. This may affect the performance of the programmable controller.

Calculation formula for the average power consumption

The power consumption of the programmable controller are roughly classified into six blocks: W_{PW} , W_{5V} , W_{24V} , W_{OUT} , W_{IN} , W_S . The total of the power consumption calculated for each block is the power consumption of the entire programmable controller system.

$$W = W_{PW} + W_{5V} + W_{24V} + W_{OUT} + W_{IN} + W_S$$

Calculate a heating value and a rise in ambient temperature inside the control panel according to the calculated power consumption (W).

For the calculation formula for each block, refer to the following.

- W_{PW} (☞ Page 289 Power consumption of a power supply module)
- W_{5V} (☞ Page 289 Total of the internal current consumption 5VDC of each module)
- W_{24V} (☞ Page 289 Total of the 24VDC average power consumption of the output module)
- W_{OUT} (☞ Page 289 Average power consumption when the voltage drop of the output module occurs)
- W_{IN} (☞ Page 289 Average power consumption at the input section of the input module)
- W_S (☞ Page 289 Power consumption of the external power supply used for each module)

Point

The total current consumption of each module can be checked by the engineering tool.

Power consumption of a power supply module

For a power supply module with the power conversion efficiency of approximately 70%, the remaining 30% is dissipated as heat, that is, 3/7 of the output power will be the power consumption.*1

Therefore, the power consumption of a power supply module, or W_{PW} , is given by the following formula:

$$W_{PW} = \frac{3}{7} \times \{ (I_{5V} \times 5) + (I_{24V} \times 24) \} (W)$$

I_{5V} : Internal current consumption 5VDC of each module

I_{24V} : Average current consumption (current consumption for the number of simultaneous on points) of 24VDC power supply for the output module internal consumption

This does not apply to a case where a power supply module that does not have the 24VDC output is used and 24VDC is supplied from the outside.

*1 The value 3/7 varies according to the power conversion efficiency. For example, for a module with the power conversion efficiency of approximately 75%, the remaining 25% is dissipated as heat, that is, 1/3 (=25%/75%) of the output power will be the power. Check the efficiency of the power supply module used and determine the value. (Page 137 Performance Specifications of Power Supply Module)

Total of the internal current consumption 5VDC of each module

The power consumption of the 5VDC output in the power supply module is that of each module including the base unit and CPU module.*1

The total of the internal current consumption 5VDC of each module, or W_{5V} , is given by the following formula:

$$W_{5V} = I_{5V} \times 5(W)$$

*1 For the power consumption of the Motion CPU, refer to the following.

📖 MELSEC iQ-R Motion Controller User's Manual

For the power consumption of the NCCPU, refer to the following.

📖 C80 Series Connection and Setup Manual

For the power consumption of the robot CPU, refer to the following.

📖 Standard Specifications Manual for the controller used

Total of the 24VDC average power consumption of the output module

The average power consumption (power consumption for the number of simultaneous on points) of the 24VDC power supply for the output module internal consumption is equal to the total power consumption of each output module.

The total average power consumption 24VDC of output modules, or W_{24V} , is given by the following formula:

$$W_{24V} = I_{24V} \times 24 \times \text{Simultaneous on ratio} (W)$$

Average power consumption when the voltage drop of the output module occurs

The average power consumption (power consumption for the number of simultaneous on points) due to a voltage drop at the output sections of output modules, or W_{OUT} , is given by the following formula:

$$W_{OUT} = I_{OUT} \times V_{drop} \times \text{Number of output points} \times \text{Simultaneous on ratio} (W)$$

I_{OUT} : Output current (current in actual use) (A)

V_{drop} : Voltage drop of each output module (V)

Average power consumption at the input section of the input module

The average power consumption (power consumption for the number of simultaneous on points) at the input sections of input modules, or W_{IN} , is given by the following formula:

$$W_{IN} = I_{IN} \times E \times \text{Number of input points} \times \text{Simultaneous on ratio} (W)$$

I_{IN} : Input current (effective value for AC) (A)

E: Input voltage (voltage in actual use) (V)

Power consumption of the external power supply used for each module

The power consumption of the external power supply section of each intelligent function module, or W_S , is given by the following formula:

$$W_S = I_{24V} \times 24(W)$$

Calculation examples for the average power consumption

System configuration

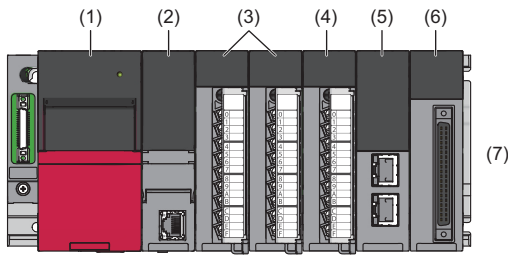

■5VDC/24VDC current consumption of each module

No.	Module or unit	5VDC	24VDC
(1)	Power supply module	—	—
(2)	CPU module	0.69A	—
(3)	Input module	0.04A	—
(4)	Output module	0.052A	0.01A
(5)	Network module	0.6A	—
(6)	Intelligent function module	0.272A	0.192A
(7)	Base unit	0.22A	—

Power consumption of each block

■Power consumption of power supply module

$$W_{PW} = 3/7 \times (0.69 + 0.04 + 0.04 + 0.052 + 0.6 + 0.272 + 0.22) \times 5 = 4.10(W)$$

■Total power consumption for 5VDC logic circuits of all module

$$W_{5V} = (0.69 + 0.04 + 0.04 + 0.052 + 0.6 + 0.272 + 0.22) \times 5 = 9.57(W)$$

■Total of the 24VDC average power consumption of the output module

$$W_{24V} = 0.01 \times 24 \times 1 = 0.24(W)$$

■Average power consumption when the voltage drop of the output module occurs

$$W_{OUT} = 0.1 \times 0.2 \times 16 \times 1 = 0.32(W)$$

■Average power consumption at the input section of the input module

$$W_{IN} = 0.004 \times 24 \times 32 \times 1 = 3.07(W)$$

■Power consumption of the external power supply used for each module

$$W_S = 0.192 \times 24 = 4.61(W)$$

Power consumption of the overall system

$$W = 4.10 + 9.57 + 0.24 + 0.32 + 3.07 + 4.61 = 21.91(W)$$

Appendix 11 Precautions for Battery Transportation

When transporting lithium batteries, follow the transportation regulations.

Regulated models

The batteries for the CPU module are classified as shown below.

Model	Supply status	Classification for transportation
Q7BATN	Lithium battery	Dangerous goods
Q7BAT	Lithium battery	Dangerous goods
Q6BAT	Lithium battery	Dangerous goods
FX3U-32BL	Lithium battery	Non-dangerous goods

Transport guidelines

Products are packed in compliance with the transportation regulations prior to shipment. When repacking any of the unpacked products for transportation, make sure to observe the IATA Dangerous Goods Regulations, IMDG (International Maritime Dangerous Goods) Code, and other local transportation regulations.

For details, please consult the shipping carrier used.

Appendix 12 Handling of Batteries and Devices with Built-In Batteries in EU Member States

This section describes the precautions for disposing of waste batteries in EU member states and exporting batteries and/or devices with built-in batteries to EU member states.

Disposal precautions

In EU member states, there is a separate collection system for waste batteries. Dispose of batteries properly at the local community waste collection/recycling center.

The following symbol mark is printed on the batteries and packaging of devices with built-in batteries. The symbol mark indicates that batteries need to be disposed of separately from other wastes.



The symbol mark is specified in the European Battery Regulation ((EU)2023/1542) Article 13 "Labelling and marking of batteries" and Annex VI.

Exportation precautions

The EU Battery Regulation ((EU)2023/1542) requires the following when marketing or exporting batteries and/or devices with built-in batteries to EU member states.

- To print the symbol marks (1) and (2) on batteries (If it is not possible, print them on the manuals and packaging.)
- To explain the symbol mark (1) in the manuals of the products

The requirements for the labeling and explanation of the symbol mark (1) are unchanged from the EU Battery Directive (2006/66/EC).

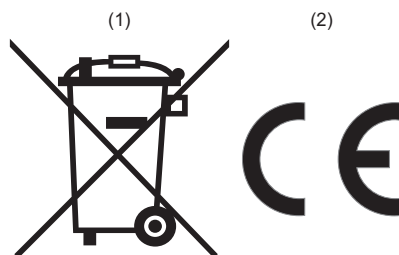

Labeling

To comply with the European Battery Regulation ((EU)2023/1542), print the symbol marks (1) and (2) on the labels attached to the batteries or the manuals and packaging. (Applicable from August 18, 2024^{*1}.)

^{*1} To market or export batteries and/or devices with built-in batteries before August 18, 2024, print the symbol mark (1) on the labels attached to the batteries or packaging to comply with the EU Battery Directive (2006/66/EC).

Explaining the symbol in the manuals

To export devices incorporating Mitsubishi programmable controller to EU member states after August 18, 2024, provide the latest manuals that include the explanation of the symbol mark (1). If the manuals of Mitsubishi programmable controller are not provided or the manuals do not include the explanation of the symbol mark (1), separately attach an explanatory note regarding the symbol mark (1) to each manual of the devices.

Point

The requirements apply to batteries and/or devices with built-in batteries manufactured before the enforcement date of the EU Battery Directive (2006/66/EC) and EU Battery Regulation ((EU)2023/1542).

Appendix 13 Type Approval Certificates for Ship Classifications

MELSEC iQ-R series programmable controllers have acquired Type Approval Certificates from classification societies. Therefore, these programmable controllers can be used for machinery or devices for marine and offshore applications. For information on the models that have been approved by the classification societies, please consult your local Mitsubishi representative.

Classification societies that issue the Type Approval Certificates

MELSEC iQ-R series have acquired the Type Approval Certificates from the following classification societies.

- American Bureau of Shipping (Abbreviation: ABS)
- Bureau Veritas (Abbreviation: BV)
- DNV GL (Abbreviation: DNV GL)
- Lloyd's Register of Shipping (Abbreviation: LR)
- Nippon Kaiji Kyokai (Abbreviation: NK)
- Registro Italiano Navale (Abbreviation: RINA)

Precautions

The precautions for using the MELSEC iQ-R series programmable controller as the approved system are as follows:

- The programmable controller must be installed in a control panel.
- Use a shielded cable for a cable coming out of the control panel.
- Make sure to attach a noise filter to the power cable.
- Make sure to attach ferrite cores to all cables that are extended out of control panels, including power cables.

For details, refer to the following.

 Precautions to acquire the Type Approval Certificate for each ship classification in ABS, BV, DNV GL, LR, NK, RINA (FA-A-0188)

Appendix 14 External Dimensions

Power supply module

- R61P, R62P, R63P, R63RP, R64P, R64RP, R69P, R69RP

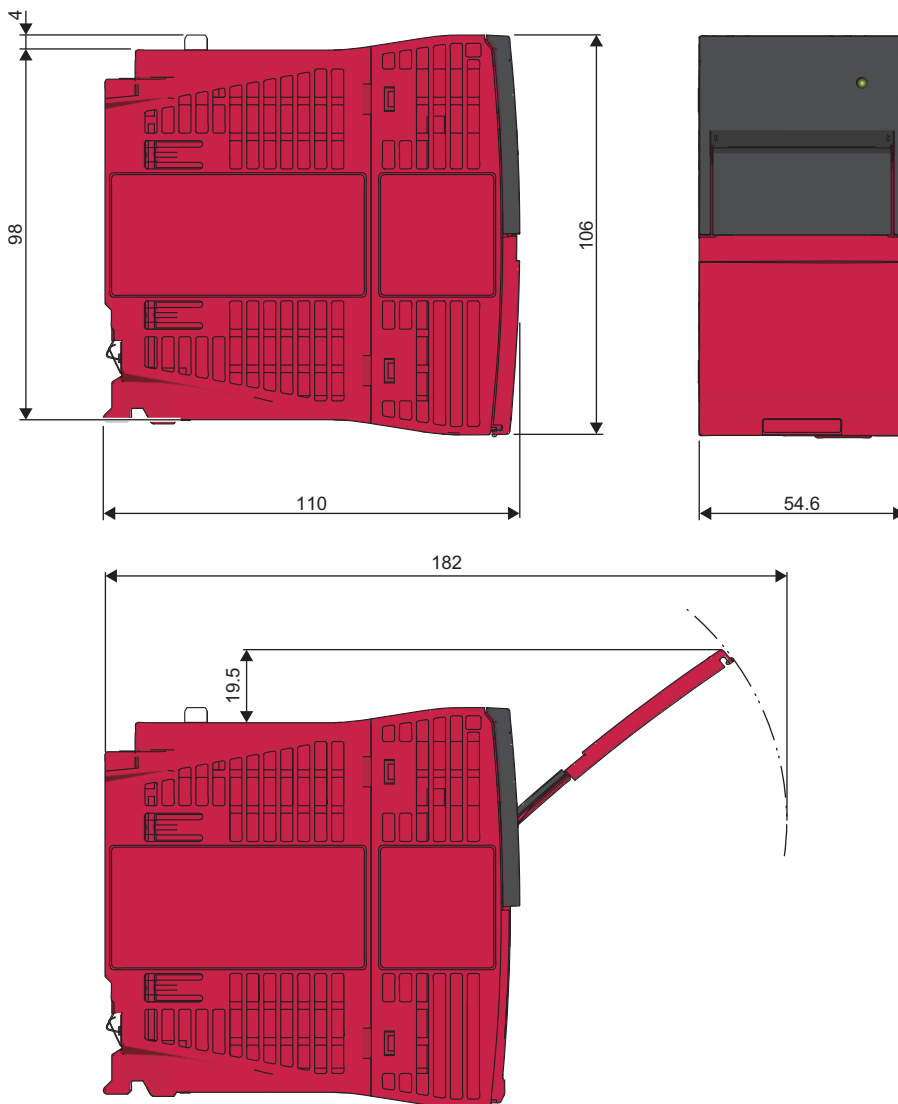

(Unit: mm)

A

• R61SP

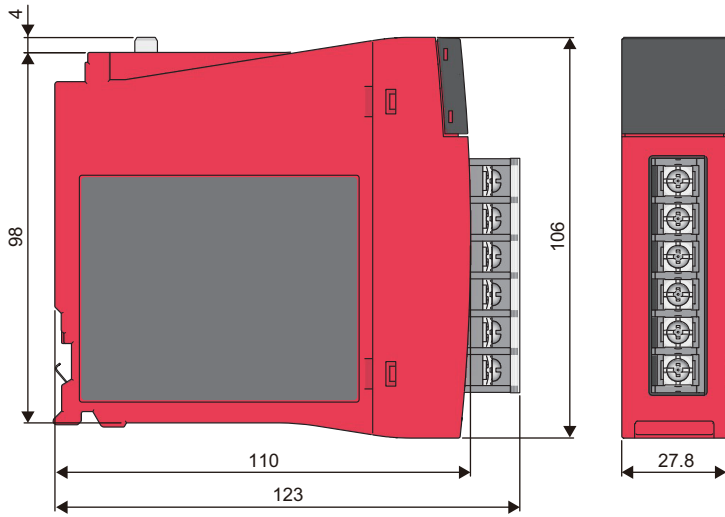

(Unit: mm)

Base unit

Main base unit

- R33B

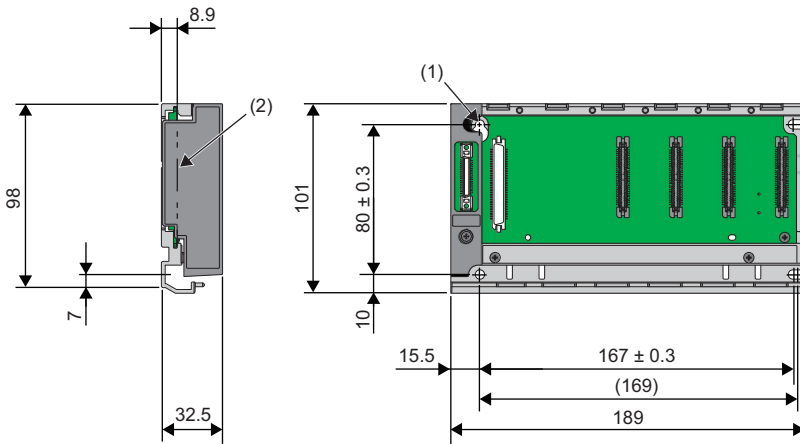

- (1) 4 installation screws (M4×14)
 - (2) Rear surface of module
- (Unit: mm)

- R35B

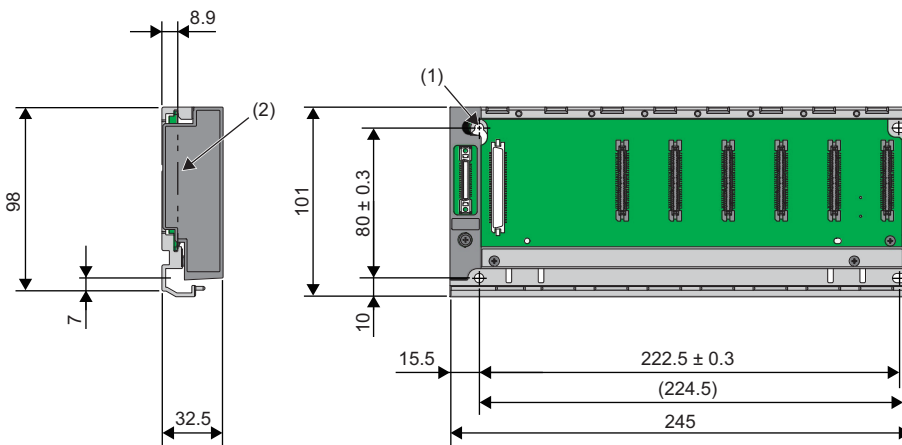

- (1) 4 installation screws (M4×14)
 - (2) Rear surface of module
- (Unit: mm)

- R38B

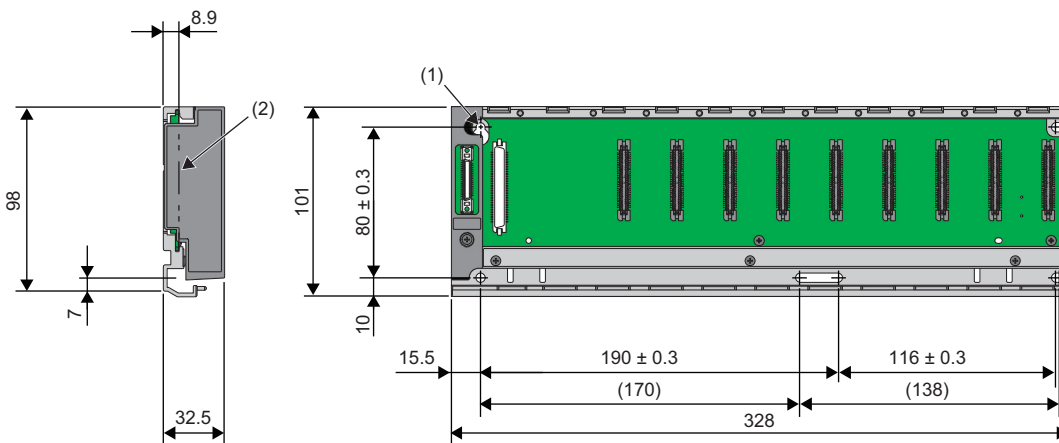

- (1) 5 installation screws (M4×14)
 - (2) Rear surface of module
- (Unit: mm)

A

• R312B

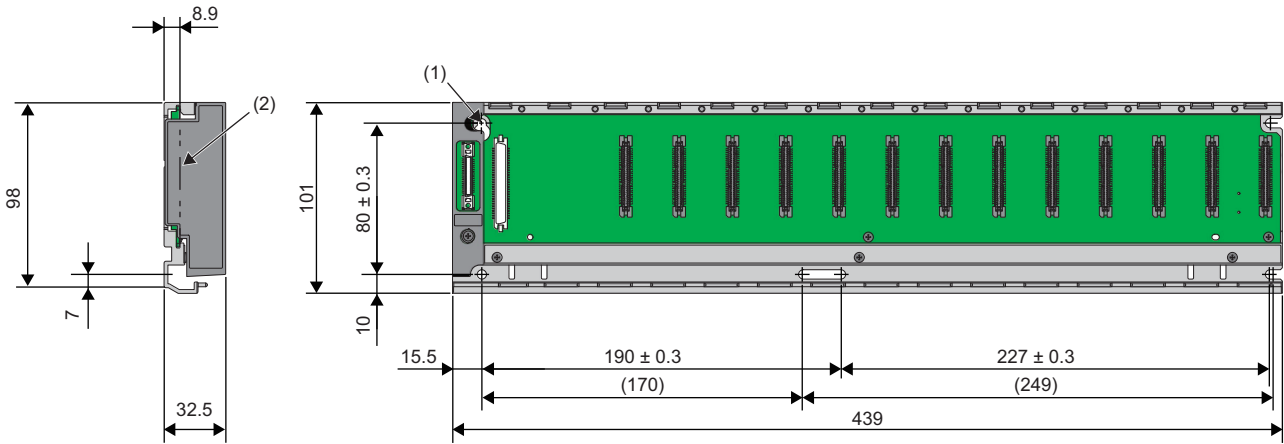

(1) 5 installation screws (M4×14)

(2) Rear surface of module

(Unit: mm)

■ Slim type main base unit

• R32SB

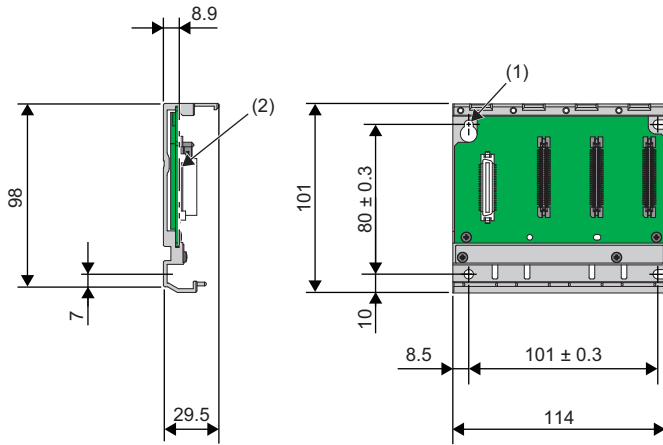

- (1) 4 installation screws (M4×14)
 - (2) Rear surface of module
- (Unit: mm)

• R33SB

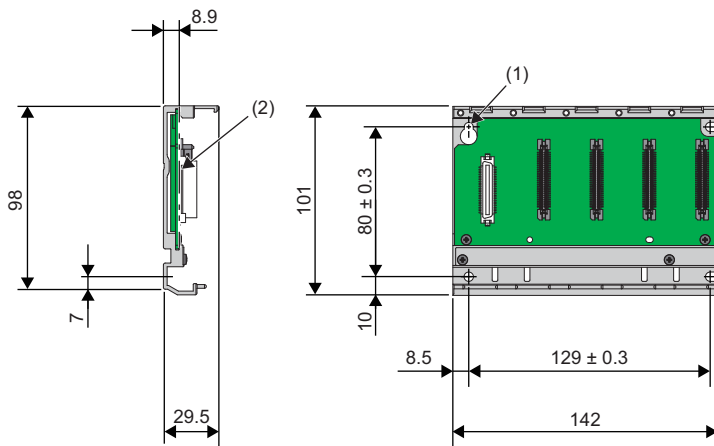

- (1) 4 installation screws (M4×14)
 - (2) Rear surface of module
- (Unit: mm)

• R35SB

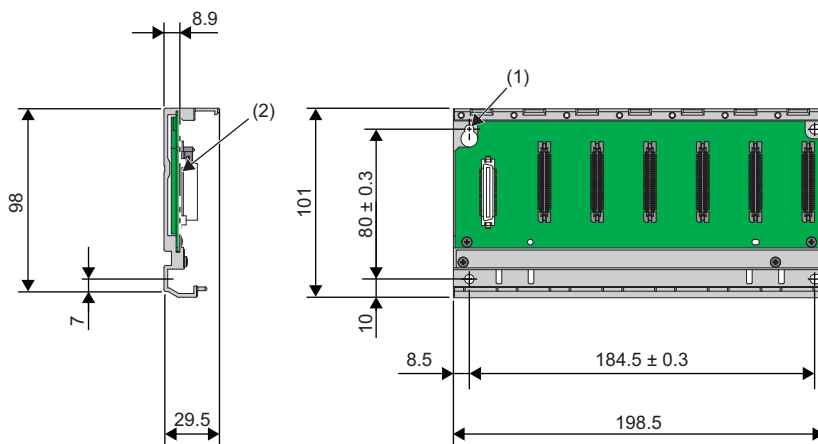

- (1) 4 installation screws (M4×14)
 - (2) Rear surface of module
- (Unit: mm)

A

Extended temperature range main base unit

• R310B-HT

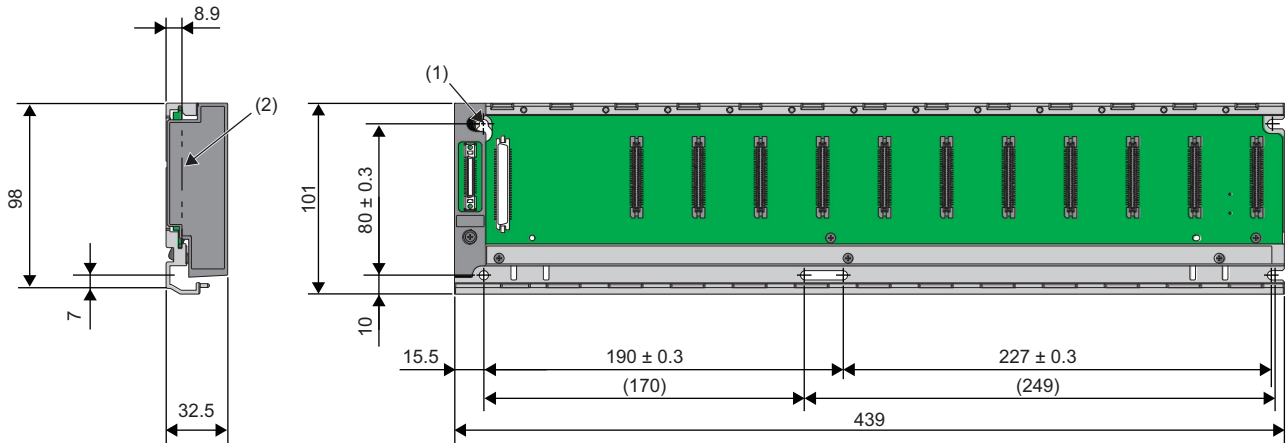

- (1) 5 installation screws (M4×14)
 - (2) Rear surface of module
- (Unit: mm)

Redundant power supply main base unit

• R310RB

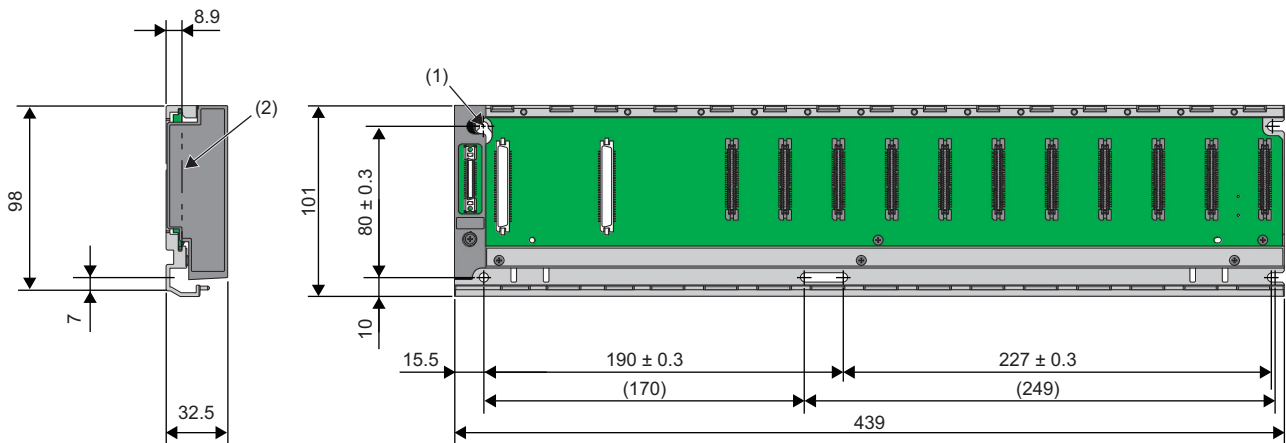

- (1) 5 installation screws (M4×14)
 - (2) Rear surface of module
- (Unit: mm)

Extended temperature range redundant power supply main base unit

• R38RB-HT

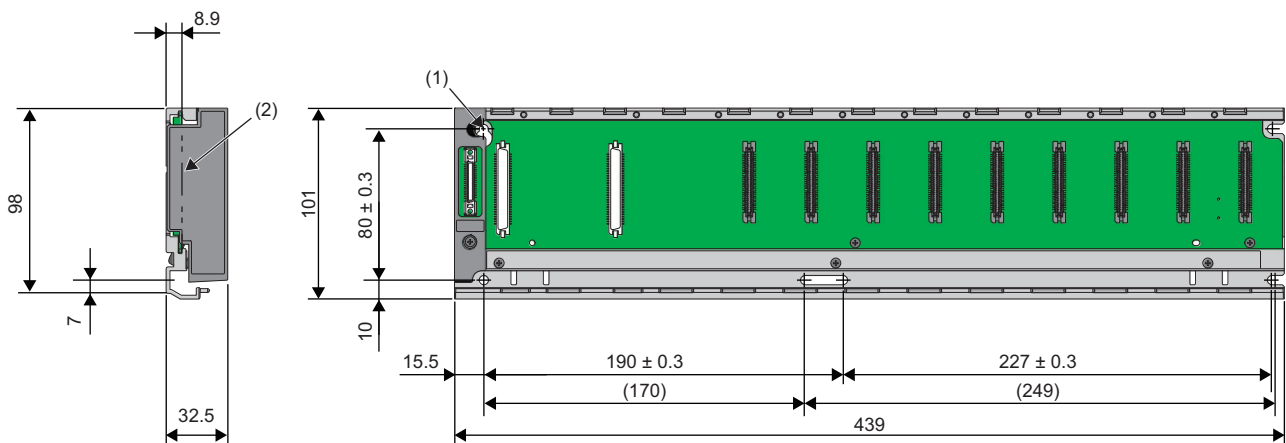

- (1) 5 installation screws (M4×14)
 - (2) Rear surface of module
- (Unit: mm)

Extension base unit

• R65B

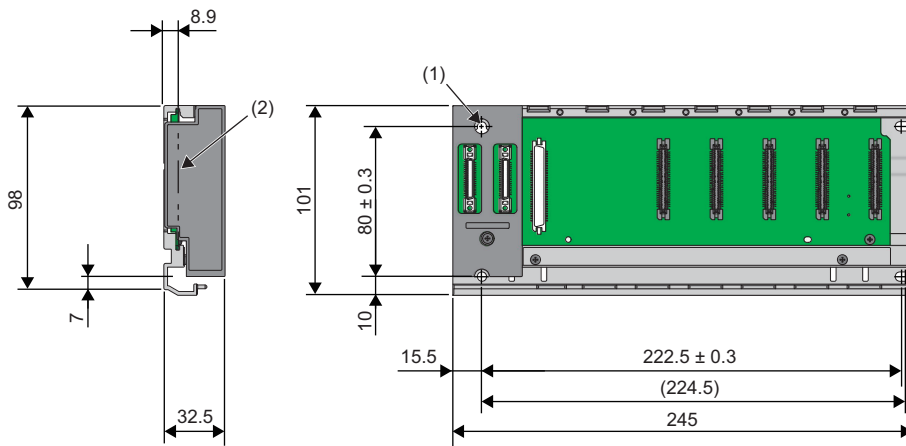

- (1) 4 installation screws (M4×14)
 - (2) Rear surface of module
- (Unit: mm)

• R68B

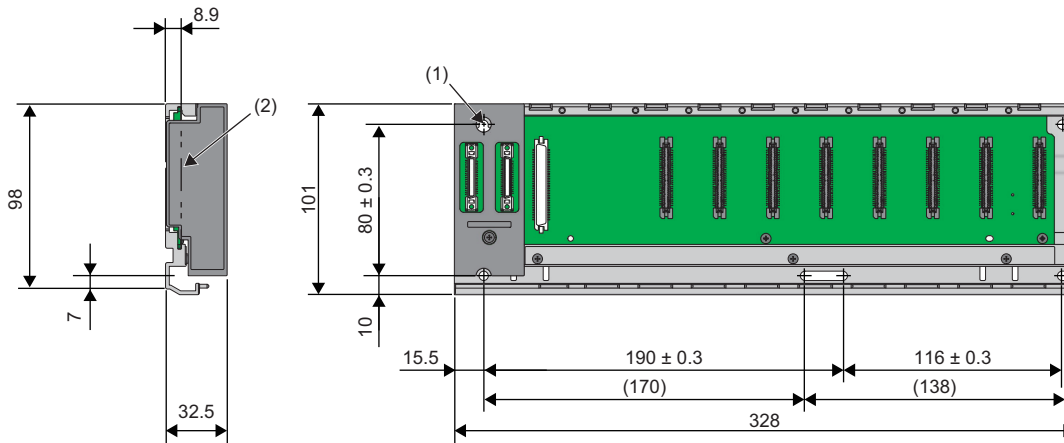

- (1) 5 installation screws (M4×14)
 - (2) Rear surface of module
- (Unit: mm)

• R612B

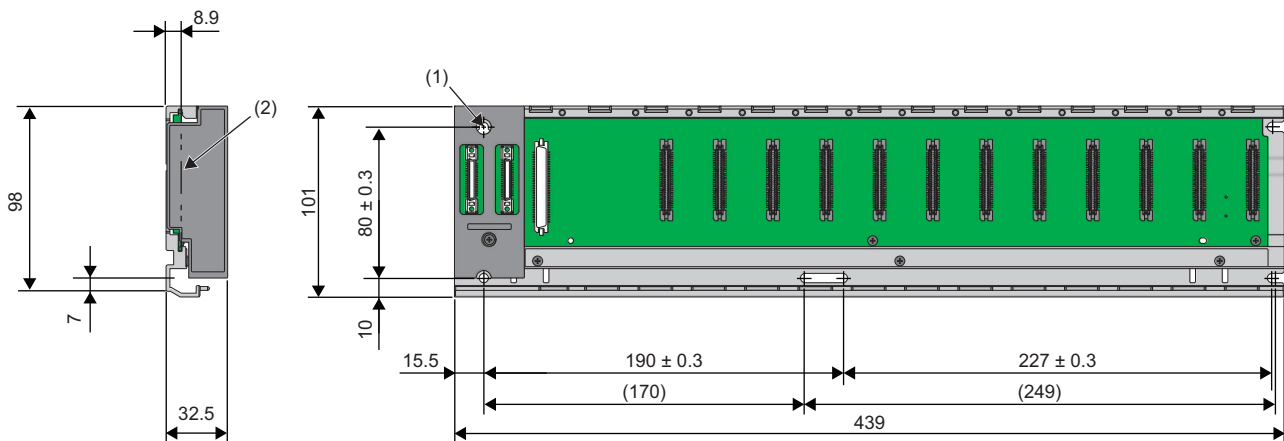

- (1) 5 installation screws (M4×14)
 - (2) Rear surface of module
- (Unit: mm)

A

Extended temperature range extension base unit

• R610B-HT

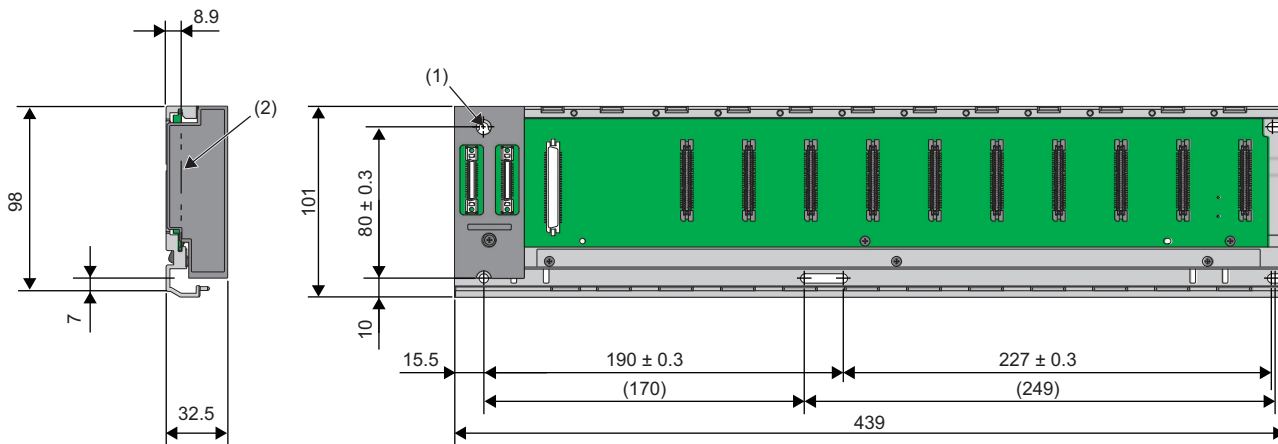

- (1) 5 installation screws (M4×14)
 - (2) Rear surface of module
- (Unit: mm)

Redundant power supply extension base unit

• R610RB

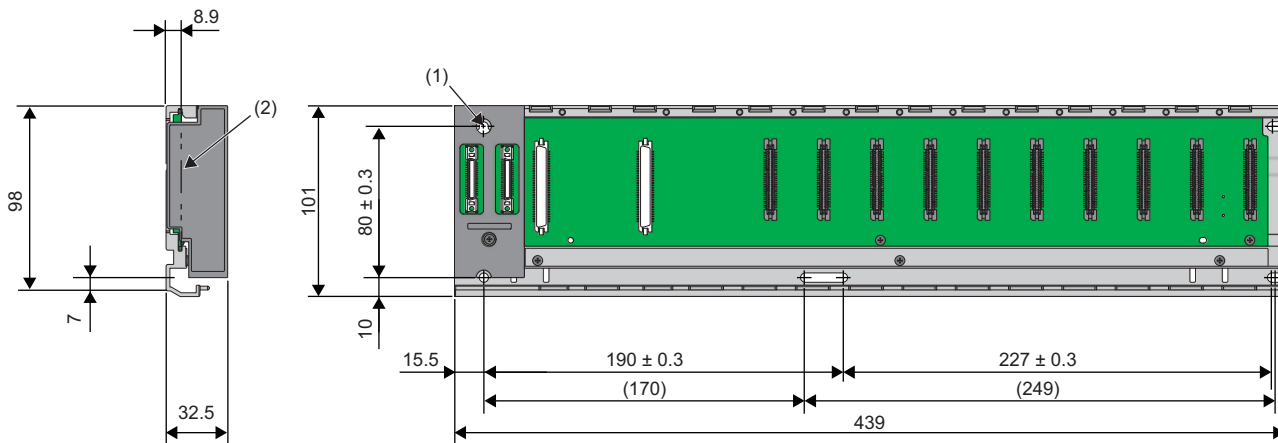

- (1) 5 installation screws (M4×14)
 - (2) Rear surface of module
- (Unit: mm)

Extended temperature range redundant power supply extension base unit

• R68RB-HT

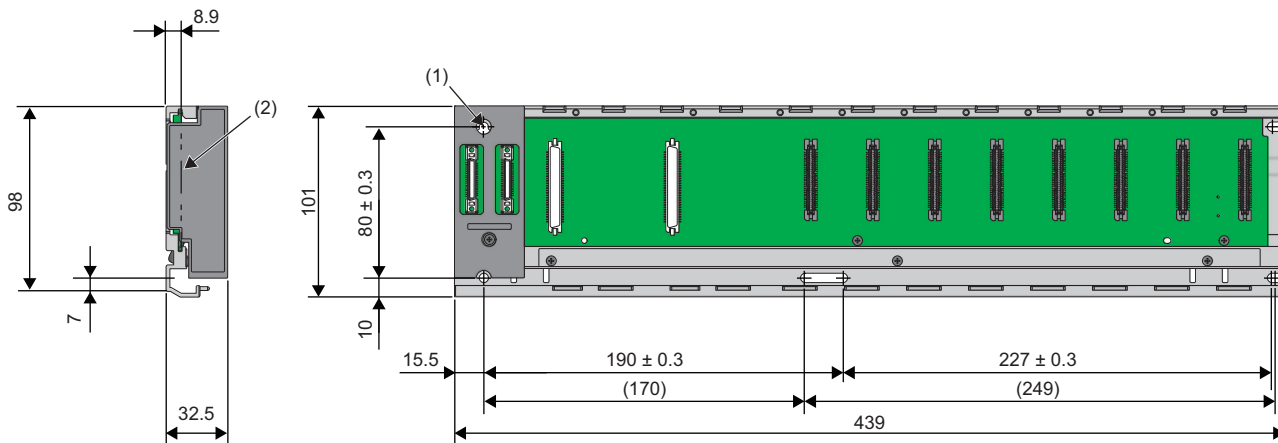

- (1) 5 installation screws (M4×14)
 - (2) Rear surface of module
- (Unit: mm)

■ Redundant extension base unit

• R68WRB

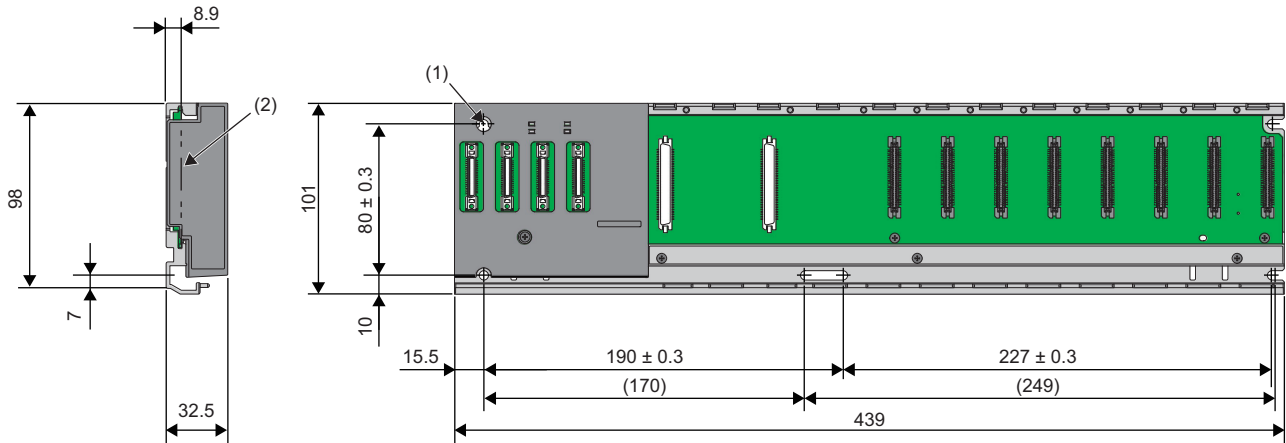

- (1) 5 installation screws (M4×14)
 - (2) Rear surface of module
- (Unit: mm)

■ Extended temperature range redundant extension base unit

• R66WRB-HT

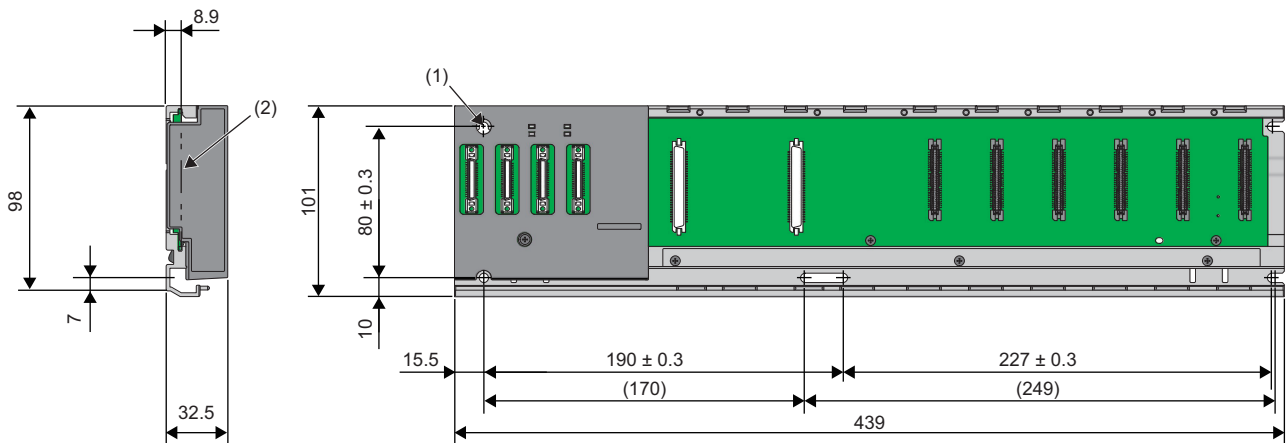

- (1) 5 installation screws (M4×14)
 - (2) Rear surface of module
- (Unit: mm)

A

RQ extension base unit

• RQ65B

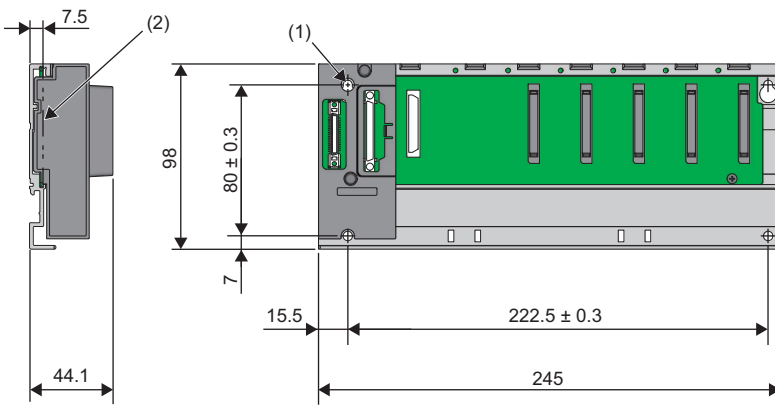

- (1) 4 installation screws (M4×14)
 - (2) Rear surface of module
- (Unit: mm)

• RQ68B

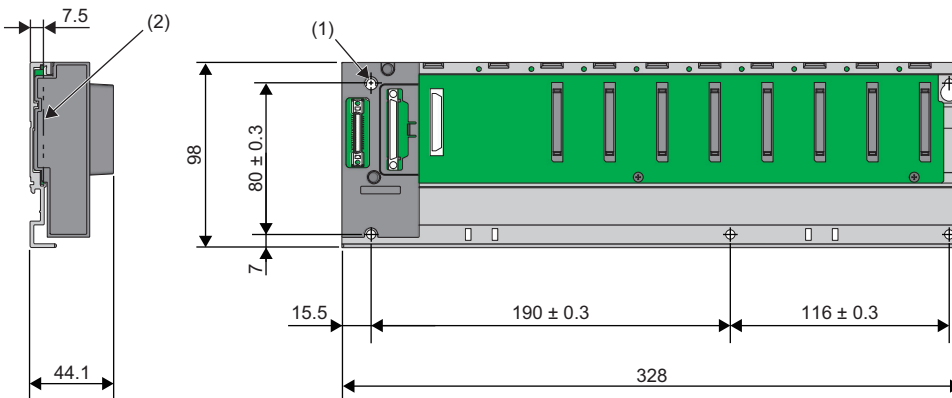

- (1) 5 installation screws (M4×14)
 - (2) Rear surface of module
- (Unit: mm)

• RQ612B

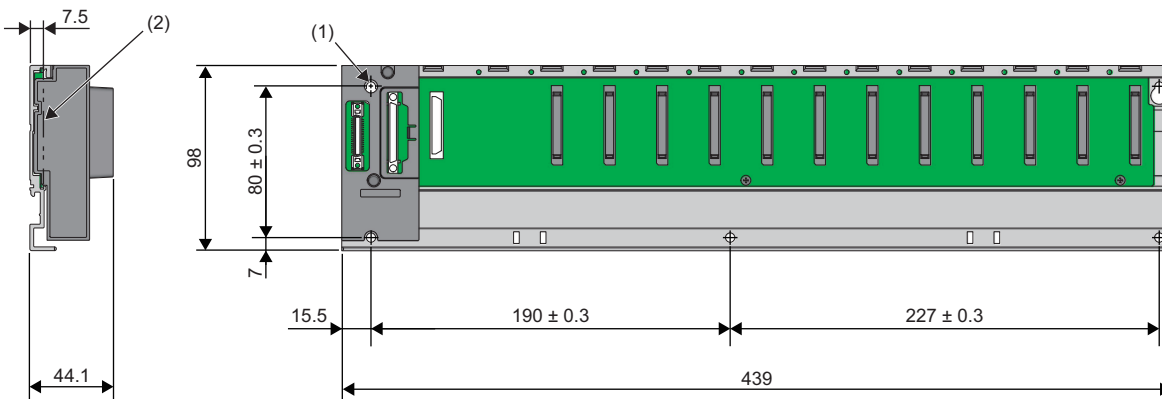

- (1) 5 installation screws (M4×14)
 - (2) Rear surface of module
- (Unit: mm)

MEMO

A

INDEX

A

Applicable software 97

B

Base unit 39
Battery life 149
Battery replacement procedure 207

C

Calculating the heating value 288
Connector pin for extension level setting 172
Consideration for internal current consumption 98
Control CPU 128
Control system 37
CPU number 126

D

Daily inspection 205
DIN rail 162

E

EMC Directive 262
Extended temperature range base unit 39
Extension base unit 39
Extension cable 39, 144
External dimensions 295

F

Ferrite core 268
Firmware update function 212

G

General safety requirements 282
General specifications 136

I

I/O module 39
I/O numbers 117
Intelligent function module 37

L

Lateral dimensions 169
Lists of configuration devices 74
Low Voltage Directive 278

M

Main base unit 39
Module configuration window 112
Module status setting 123
Modules having restrictions on the number of mountable modules 90
Motion CPU 39

Multiple CPU system 45

N

NCCPU 39
Network module 39
Noise filter 265

P

Periodic inspection 206
Power supply module 39
Process CPU 39
Process CPU (process mode) 37
Process CPU (redundant mode) 37
Production information 210
Programmable controller CPU 39

R

Redundant extension base unit 39, 48
Redundant function module 37
Redundant power supply base unit 39
Redundant power supply module 39
Redundant power supply system 37
Redundant system 46
Redundant system with redundant extension base unit 37, 48
Remote head module 39
RnENCPU 40
RnENCPU (CPU part) 40
RnENCPU (network part) 40
Robot CPU 40
RQ extension base unit 40

S

Safety communications 38
Safety control 38
Safety CPU 37
Safety device 38
Safety function module 37
Safety program 38
Safety programmable controller 40
SIL2 function module 37
SIL2 mode 37
SIL2 Process CPU 37
Single CPU system 45
Slot numbers on a base unit 113
Standard communications 38
Standard control 38
Standard CPU 40
Standard device 38
Standard program 38
Standard programmable controller 40
Standby system 37
System A 37
System B 37
System configuration specifications 86
System parameter 112

T

Tracking cable	37
Troubleshooting by symptom	245

W

Wiring a connector	190
Wiring to a screw terminal block	183
Wiring to a spring clamp terminal block	185,186
Wiring to the power supply module	179



REVISIONS

*The manual number is given on the bottom left of the back cover.

Revision date	*Manual number	Revision
June 2014	SH(NA)-081262ENG-A	First edition
November 2014	SH(NA)-081262ENG-B	■Added or modified parts TERMS, Section 1.1, 1.2, Appendix 1, 3, 4
January 2015	SH(NA)-081262ENG-C	■Added models R62P, R64P ■Added or modified parts SAFETY PRECAUTIONS, INTRODUCTION, TERMS, Section 1.1, 1.2, 3.1, 3.3, 4.2, 4.4, 4.5, 5.7, 5.8, Chapter 6, Appendix 3, 4, 5, 6, 9
May 2015	SH(NA)-081262ENG-D	■Added or modified parts TERMS, Section 1.1, 1.2, 5.8, 6.2, Appendix 1, 3
June 2015	SH(NA)-081262ENG-E	■Added or modified parts Section 1.2
August 2015	SH(NA)-081262ENG-F	■Added or modified parts SAFETY PRECAUTIONS, CONDITIONS OF USE FOR THE PRODUCT, TERMS, Section 1.1, 1.2, 1.3, 1.4, 1.5, 4.5, 5.8, Appendix 5, WARRANTY
January 2016	SH(NA)-081262ENG-G	■Added models R310B-HT, R610B-HT ■Added or modified parts SAFETY PRECAUTIONS, TERMS, Section 1.3, 1.5, 4.1, 4.3, 5.1, 5.4, 5.7, 5.8, 6.2, Appendix 3, 5, 8, 11
May 2016	SH(NA)-081262ENG-H	■Added models R64RP, R310RB, R610RB, R38RB-HT, R68RB-HT ■Added or modified parts SAFETY PRECAUTIONS, INTRODUCTION, TERMS, Section 1.1, 1.2, 1.3, 1.5, 2.2, 2.3, 3.1, 3.2, 4.2, 4.3, 5.4, 5.7, 6.2, Appendix 2, 3, 4, 5, 6, 7, 11
September 2016	SH(NA)-081262ENG-I	■Added or modified parts Section 1.2, 1.3, 1.4, 4.4
October 2016	SH(NA)-081262ENG-J	■Added model R63RP ■Added or modified parts SAFETY PRECAUTIONS, Section 1.1, 1.2, 3.1, 4.2, 5.7, 6.2, Appendix 1, 3, 6, 12
February 2017	SH(NA)-081262ENG-K	■Added model RC100B ■Added or modified parts SAFETY PRECAUTIONS, Section 1.2, 1.4, 3.2, 4.3, 5.6, Appendix 4, 6
May 2017	SH(NA)-081262ENG-L	■Added or modified parts Section 1.2, Appendix 1
July 2017	SH(NA)-081262ENG-M	■Added or modified parts Section 1.2, 4.1, Appendix 6
October 2017	SH(NA)-081262ENG-N	■Added or modified parts SAFETY PRECAUTIONS, CONDITIONS OF USE FOR THE PRODUCT, INTRODUCTION, TERMS, Section 1.1, 1.2, 1.4, 4.5, 5.2, 6.2, Appendix 1, 2, 5, 9, 10, WARRANTY
December 2017	SH(NA)-081262ENG-O	■Added or modified parts Section 1.2, Appendix 1
April 2018	SH(NA)-081262ENG-P	■Added or modified parts SAFETY PRECAUTIONS, INTRODUCTION, TERMS, Section 1.1, 1.2, 1.3, 5.7, 5.8, Appendix 1, 6, 12, TRADEMARKS
July 2018	SH(NA)-081262ENG-Q	■Added or modified parts SAFETY PRECAUTIONS, Section 1.1, 1.2, 1.3, 5.8, Appendix 1, 2, 6
October 2018	SH(NA)-081262ENG-R	■Added models R33B ■Added or modified parts SAFETY PRECAUTIONS, Section 1.1, 1.2, 1.3, 4.3, Appendix 6, 10, 13
May 2019	SH(NA)-081262ENG-S	■Added or modified parts TERMS, GENERIC TERMS AND ABBREVIATIONS, Section 1.2, 1.3, 1.5, 4.5, 5.2, 6.2, Appendix 2, 6, 10

Revision date	*Manual number	Revision
June 2019	SH(NA)-081262ENG-T	■Added or modified parts SAFETY PRECAUTIONS, GENERIC TERMS AND ABBREVIATIONS, Section 1.2, Appendix 6
August 2019	SH(NA)-081262ENG-U	■Added or modified parts TERMS, GENERIC TERMS AND ABBREVIATIONS, Section 1.2, 1.3, Appendix 5, 13
October 2019	SH(NA)-081262ENG-V	■Added or modified parts SAFETY PRECAUTIONS, Section 1.2, Appendix 2, 7, 14
December 2019	SH(NA)-081262ENG-W	■Added or modified parts Section 1.2
February 2020	SH(NA)-081262ENG-X	■Added or modified parts SAFETY PRECAUTIONS, GENERIC TERMS AND ABBREVIATIONS, Section 1.1, 1.2, 1.3
May 2020	SH(NA)-081262ENG-Y	■Added or modified parts SAFETY PRECAUTIONS, Section 1.1, 1.2, 1.3, 1.4, 1.5, 4.5, Appendix 2, 7
July 2020	SH(NA)-081262ENG-Z	■Added or modified parts SAFETY PRECAUTIONS, CONDITIONS OF USE FOR THE PRODUCT, Section 1.2, 1.3, 1.5, Appendix 2
October 2020	SH(NA)-081262ENG-AA	■Added model R68WRB ■Added or modified parts SAFETY PRECAUTIONS, TERMS, GENERIC TERMS AND ABBREVIATIONS, Section 1.1, 1.2, 1.3, 1.5, 3.1, 3.2, 4.1, 4.3, 5.5, Appendix 2, 4, 14
January 2021	SH(NA)-081262ENG-AB	■Added models R66WRB-HT, RD81RC96-CA, RJ71GB91 ■Added or modified parts Section 1.2, 1.3, 1.5, 3.2, 4.3, 5.4, Appendix 2, 7, 14
April 2021	SH(NA)-081262ENG-AC	■Added or modified parts Section 1.2, 1.3, 4.1, 5.7, Appendix 2
May 2021	SH(NA)-081262ENG-AD	■Added or modified parts Section 1.2, 1.3, 1.5
September 2021	SH(NA)-081262ENG-AE	■Added or modified parts SAFETY PRECAUTIONS, Section 3.2, 5.6, 5.7, Appendix 7
October 2021	SH(NA)-081262ENG-AF	■Added or modified parts SAFETY PRECAUTIONS, Section 1.2, Appendix 2
January 2022	SH(NA)-081262ENG-AG	■Added or modified parts SAFETY PRECAUTIONS, INTRODUCTION, GENERIC TERMS AND ABBREVIATIONS, Section 1.2, 1.3, 1.4, 1.5, 4.4, 4.5, 4.6, 5.2, 5.8, Chapter 6, Appendix 2, 7, 6, 9
May 2022	SH(NA)-081262ENG-AH	■Added or modified parts SAFETY PRECAUTIONS, INTRODUCTION, Section 1.2, Appendix 14
September 2022	SH(NA)-081262ENG-AI	■Added or modified parts SAFETY PRECAUTIONS, INTRODUCTION, Chapter 1, 2, 3, 5, Appendix 7
December 2022	SH(NA)-081262ENG-AJ	■Added or modified parts CONDITIONS OF USE FOR THE PRODUCT, Section 1.1, Appendix 2, WARRANTY
April 2023	SH(NA)-081262ENG-AK	■Added model RJ71BR11 ■Added or modified parts SAFETY PRECAUTIONS, Section 1.1, 1.2, 1.3, 1.5, Appendix 2, 7
May 2023	SH(NA)-081262ENG-AL	■Added model RJ71GN11-SX ■Added or modified parts SAFETY PRECAUTIONS, GENERIC TERMS AND ABBREVIATIONS, Section 1.2, 1.3, 1.5, 5.7, 6.2, Appendix 2, 7
June 2023	SH(NA)-081262ENG-AM	■Added models R69P, R69RP ■Added or modified parts INTRODUCTION, Section 1.2, 1.3, 1.4, 1.5, 4.2, 4.4, Chapter 6, Appendix 2, 6, 9, 14
October 2023	SH(NA)-081262ENG-AN	■Added or modified parts Section 5.7, Appendix 2

Revision date	*Manual number	Revision
January 2024	SH(NA)-081262ENG-AO	<ul style="list-style-type: none"> ■Added model RX40NC6S-TS, RY48PT20S-TS ■Added or modified parts SAFETY PRECAUTIONS, Section 1.1, 1.2, 1.3, 4.3, Appendix 2
April 2024	SH(NA)-081262ENG-AP	<ul style="list-style-type: none"> ■Added or modified parts Section 1.1, 1.3
June 2024	SH(NA)-081262ENG-AQ	<ul style="list-style-type: none"> ■Added or modified parts Section 1.2, 1.3, 1.5
December 2024	SH(NA)-081262ENG-AR	<ul style="list-style-type: none"> ■Added models R61SP, R32SB, R33SB, R35SB ■Added or modified parts Section 1.1, 1.2, 1.3, 1.5, 3.2, 4.1, 4.2, 4.3, 4.4, 5.2, 5.4, Appendix 7, 12, 14
April 2025	SH(NA)-081262ENG-AS	<ul style="list-style-type: none"> ■Added or modified parts SAFETY PRECAUTIONS, Section 1.2, 1.3, 4.1, 5.2, 5.7, Appendix 2
July 2025	SH(NA)-081262ENG-AT	<ul style="list-style-type: none"> ■Added or modified parts SAFETY PRECAUTIONS, Section 1.2, Appendix 2
October 2025	SH(NA)-081262ENG-AU	<ul style="list-style-type: none"> ■Added model R60TRD4-G ■Added or modified parts SAFETY PRECAUTIONS, CONDITIONS OF USE FOR THE PRODUCT, Section 1.2, 1.3, 2.2, Appendix 2

Japanese manual number: SH-081222-AV

This manual confers no industrial property rights or any rights of any other kind, nor does it confer any patent licenses. Mitsubishi Electric Corporation cannot be held responsible for any problems involving industrial property rights which may occur as a result of using the contents noted in this manual.

© 2014 MITSUBISHI ELECTRIC CORPORATION

WARRANTY

Please confirm the following product warranty details before using this product.

1. Gratis Warranty Term and Gratis Warranty Range

If any faults or defects (hereinafter "Failure") found to be the responsibility of Mitsubishi occurs during use of the product within the gratis warranty term, the product shall be repaired at no cost via the sales representative or Mitsubishi Service Company.

However, if repairs are required onsite at domestic or overseas location, expenses to send an engineer will be solely at the customer's discretion. Mitsubishi shall not be held responsible for any re-commissioning, maintenance, or testing on-site that involves replacement of the failed module.

[Gratis Warranty Term]

The gratis warranty term of the product shall be for one year after the date of purchase or delivery to a designated place. Note that after manufacture and shipment from Mitsubishi, the maximum distribution period shall be six (6) months, and the longest gratis warranty term after manufacturing shall be eighteen (18) months. The gratis warranty term of repair parts shall not exceed the gratis warranty term before repairs.

[Gratis Warranty Range]

- (1) The range shall be limited to normal use within the usage state, usage methods and usage environment, etc., which follow the conditions and precautions, etc., given in the instruction manual, user's manual and caution labels on the product.
- (2) Even within the gratis warranty term, repairs shall be charged for in the following cases.
 1. Failure occurring from inappropriate storage or handling, carelessness or negligence by the user. Failure caused by the user's hardware or software design.
 2. Failure caused by unapproved modifications, etc., to the product by the user.
 3. When the Mitsubishi product is assembled into a user's device, Failure that could have been avoided if functions or structures, judged as necessary in the legal safety measures the user's device is subject to or as necessary by industry standards, had been provided.
 4. Failure that could have been avoided if consumable parts (battery, backlight, fuse, etc.) designated in the instruction manual had been correctly serviced or replaced.
 5. Failure caused by external irresistible forces such as fires or abnormal voltages, and Failure caused by force majeure such as earthquakes, lightning, wind and water damage.
 6. Failure caused by reasons unpredictable by scientific technology standards at time of shipment from Mitsubishi.
 7. Any other failure found not to be the responsibility of Mitsubishi or that admitted not to be so by the user.

2. Onerous repair term after discontinuation of production

- (1) Mitsubishi shall accept onerous product repairs for seven (7) years after production of the product is discontinued. Discontinuation of production shall be notified with Mitsubishi Technical Bulletins, etc.
- (2) Product supply (including repair parts) is not available after production is discontinued.

3. Overseas service

Overseas, repairs shall be accepted by Mitsubishi's local overseas FA Center. Note that the repair conditions at each FA Center may differ.

4. Exclusion of loss in opportunity and secondary loss from warranty liability

Regardless of the gratis warranty term, Mitsubishi shall not be liable for compensation to:

- (1) Damages caused by any cause found not to be the responsibility of Mitsubishi.
- (2) Loss in opportunity, lost profits incurred to the user by Failures of Mitsubishi products.
- (3) Special damages and secondary damages whether foreseeable or not, compensation for accidents, and compensation for damages to products other than Mitsubishi products.
- (4) Replacement by the user, maintenance of on-site equipment, start-up test run and other tasks.

5. Changes in product specifications

The specifications given in the catalogs, manuals or technical documents are subject to change without prior notice.

· For SIL2 Process CPUs

Please confirm the following product warranty details before using this product.

1. Limited Warranty and Product Support.

- a. Mitsubishi Electric Corporation ("MELCO") warrants that for a period of eighteen (18) months after date of delivery from the point of manufacture or one year from date of Customer's purchase, whichever is less, Mitsubishi programmable logic controllers (the "Products") will be free from defects in material and workmanship.
- b. At MELCO's option, for those Products MELCO determines are not as warranted, MELCO shall either repair or replace them or issue a credit or return the purchase price paid for them.
- c. For this warranty to apply:
 - (1) Customer shall give MELCO (i) notice of a warranty claim to MELCO and the authorized dealer or distributor from whom the Products were purchased, (ii) the notice shall describe in reasonable details the warranty problem, (iii) the notice shall be provided promptly and in no event later than thirty (30) days after the Customer knows or has reason to believe that Products are not as warranted, and (iv) in any event, the notice must be given within the warranty period;
 - (2) Customer shall cooperate with MELCO and MELCO's representatives in MELCO's investigation of the warranty claim, including preserving evidence of the claim and its causes, meaningfully responding to MELCO's questions and investigation of the problem, grant MELCO access to witnesses, personnel, documents, physical evidence and records concerning the warranty problem, and allow MELCO to examine and test the Products in question offsite or at the premises where they are installed or used; and
 - (3) If MELCO requests, Customer shall remove Products it claims are defective and ship them to MELCO or MELCO's authorized representative for examination and, if found defective, for repair or replacement. The costs of removal, shipment to and from MELCO's designated examination point, and reinstallation of repaired or replaced Products shall be at Customer's expense.
 - (4) If Customer requests and MELCO agrees to effect repairs onsite at any domestic or overseas location, the Customer will pay for the costs of sending repair personnel and shipping parts. MELCO is not responsible for any re-commissioning, maintenance, or testing on-site that involves repairs or replacing of the Products.
- d. Repairs of Products located outside of Japan are accepted by MELCO's local authorized service facility centers ("FA Centers"). Terms and conditions on which each FA Center offers repair services for Products that are out of warranty or not covered by MELCO's limited warranty may vary.
- e. Subject to availability of spare parts, MELCO will offer Product repair services for (7) years after each Product model or line is discontinued, at MELCO's or its FA Centers' rates and charges and standard terms in effect at the time of repair. MELCO usually produces and retains sufficient spare parts for repairs of its Products for a period of seven (7) years after production is discontinued.
- f. MELCO generally announces discontinuation of Products through MELCO's Technical Bulletins. Products discontinued and repair parts for them may not be available after their production is discontinued.

2. Limits of Warranties.

- a. MELCO does not warrant or guarantee the design, specify, manufacture, construction or installation of the materials, construction criteria, functionality, use, properties or other characteristics of the equipment, systems, or production lines into which the Products may be incorporated, including any safety, fail-safe and shut down systems using the Products.
- b. MELCO is not responsible for determining the suitability of the Products for their intended purpose and use, including determining if the Products provide appropriate safety margins and redundancies for the applications, equipment or systems into which they are incorporated.
- c. Customer acknowledges that qualified and experienced personnel are required to determine the suitability, application, design, construction and proper installation and integration of the Products. MELCO does not supply such personnel.
- d. MELCO is not responsible for designing and conducting tests to determine that the Product functions appropriately and meets application standards and requirements as installed or incorporated into the end-user's equipment, production lines or systems.
- e. MELCO does not warrant any Product:
 - (1) repaired or altered by persons other than MELCO or its authorized engineers or FA Centers;
 - (2) subjected to negligence, carelessness, accident, misuse, or damage;
 - (3) improperly stored, handled, installed or maintained;
 - (4) integrated or used in connection with improperly designed, incompatible or defective hardware or software;
 - (5) that fails because consumable parts such as batteries, backlights, or fuses were not tested, serviced or replaced;
 - (6) operated or used with equipment, production lines or systems that do not meet applicable and commensurate legal, safety and industry-accepted standards;
 - (7) operated or used in abnormal applications;
 - (8) installed, operated or used in contravention of instructions, precautions or warnings contained in MELCO's user, instruction and/or safety manuals, technical bulletins and guidelines for the Products;
 - (9) used with obsolete technologies or technologies not fully tested and widely accepted and in use at the time of the Product's manufacture;
 - (10) subjected to excessive heat or moisture, abnormal voltages, shock, excessive vibration, physical damage or other improper environment; or
 - (11) damaged or malfunctioning due to Acts of God, fires, acts of vandals, criminals or terrorists, communication or power failures, or any other cause or failure that results from circumstances beyond MELCO's control.
- f. All Product information and specifications contained on MELCO's website and in catalogs, manuals, or technical information materials provided by MELCO are subject to change without prior notice.

- g. The Product information and statements contained on MELCO's website and in catalogs, manuals, technical bulletins or other materials provided by MELCO are provided as a guide for Customer's use. They do not constitute warranties and are not incorporated in the contract of sale for the Products.
- h. These terms and conditions constitute the entire agreement between Customer and MELCO with respect to warranties, remedies and damages and supersede any other understandings, whether written or oral, between the parties. Customer expressly acknowledges that any representations or statements made by MELCO or others concerning the Products outside these terms are not part of the basis of the bargain between the parties and are not factored into the pricing of the Products.
- i. THE WARRANTIES AND REMEDIES SET FORTH IN THESE TERMS ARE THE EXCLUSIVE AND ONLY WARRANTIES AND REMEDIES THAT APPLY TO THE PRODUCTS.
- j. MELCO DISCLAIMS THE IMPLIED WARRANTIES OF MERCHANTABILITY AND FITNESS FOR A PARTICULAR PURPOSE.

3. Limits on Damages.

- a. MELCO'S MAXIMUM CUMULATIVE LIABILITY BASED ON ANY CLAIMS FOR BREACH OF WARRANTY OR CONTRACT, NEGLIGENCE, STRICT TORT LIABILITY OR OTHER THEORIES OF RECOVERY REGARDING THE SALE, REPAIR, REPLACEMENT, DELIVERY, PERFORMANCE, CONDITION, SUITABILITY, COMPLIANCE, OR OTHER ASPECTS OF THE PRODUCTS OR THEIR SALE, INSTALLATION OR USE SHALL BE LIMITED TO THE PRICE PAID FOR PRODUCTS NOT AS WARRANTED.
- b. The Product has been certified by a third-party certification body as being in compliance with the IEC 61508 safety standards and meets the requirements of the IEC 61511 safety standards. However, this does not guarantee that the Product is free from malfunctions or failures. The user of this Product shall comply with any and all applicable safety standard, regulation or law and take appropriate safety measures for the system in which the Product is installed or used and shall take the second or third safety measures other than the Product. MELCO is not liable for damages that could have been prevented by compliance with any applicable safety standard, regulation or law.
- c. MELCO prohibits the use of Products with or in any application involving power plants, trains, railway systems, airplanes, airline operations, other transportation systems, amusement equipments, hospitals, medical care, dialysis and life support facilities or equipment, incineration and fuel devices, handling of nuclear or hazardous materials or chemicals, mining and drilling, and other applications where the level of risk to human life, health or property are elevated.
- d. MELCO SHALL NOT BE LIABLE FOR SPECIAL, INCIDENTAL, CONSEQUENTIAL, INDIRECT OR PUNITIVE DAMAGES, FOR LOSS OF PROFITS, SALES, OR REVENUE, FOR INCREASED LABOR OR OVERHEAD COSTS, FOR DOWNTIME OR LOSS OF PRODUCTION, FOR COST OVERRUNS, OR FOR ENVIRONMENTAL OR POLLUTION DAMAGES OR CLEAN-UP COSTS, WHETHER THE LOSS IS BASED ON CLAIMS FOR BREACH OF CONTRACT OR WARRANTY, VIOLATION OF STATUTE, NEGLIGENCE OR OTHER TORT, STRICT LIABILITY OR OTHERWISE.
- e. In the event that any damages which are asserted against MELCO arising out of or relating to the Products or defects in them, consist of personal injury, wrongful death and/or physical property damages as well as damages of a pecuniary nature, the disclaimers and limitations contained in these terms shall apply to all three types of damages to the fullest extent permitted by law. If, however, the personal injury, wrongful death and/or physical property damages cannot be disclaimed or limited by law or public policy to the extent provided by these terms, then in any such event the disclaimer of and limitations on pecuniary or economic consequential and incidental damages shall nevertheless be enforceable to the fullest extent allowed by law.
- f. In no event shall any cause of action arising out of breach of warranty or otherwise concerning the Products be brought by Customer more than one year after the cause of action accrues.
- g. Each of the limitations on remedies and damages set forth in these terms is separate and independently enforceable, notwithstanding the unenforceability or failure of essential purpose of any warranty, undertaking, damage limitation, other provision of these terms or other terms comprising the contract of sale between Customer and MELCO.

4. Delivery/Force Majeure.

- a. Any delivery date for the Products acknowledged by MELCO is an estimated and not a promised date. MELCO will make all reasonable efforts to meet the delivery schedule set forth in Customer's order or the purchase contract but shall not be liable for failure to do so.
- b. Products stored at the request of Customer or because Customer refuses or delays shipment shall be at the risk and expense of Customer.
- c. MELCO shall not be liable for any damage to or loss of the Products or any delay in or failure to deliver, service, repair or replace the Products arising from shortage of raw materials, failure of suppliers to make timely delivery, labor difficulties of any kind, earthquake, fire, windstorm, flood, theft, criminal or terrorist acts, war, embargoes, governmental acts or rulings, loss or damage or delays in carriage, acts of God, vandals or any other circumstances reasonably beyond MELCO's control.

5. Choice of Law/Jurisdiction.

These terms and any agreement or contract between Customer and MELCO shall be governed by the laws of the State of New York without regard to conflicts of laws. To the extent any action or dispute is not arbitrated, the parties consent to the exclusive jurisdiction and venue of the federal and state courts located in the Southern District of the State of New York. Any judgment there obtained may be enforced in any court of competent jurisdiction.

6. Arbitration.

Any controversy or claim arising out of, or relating to or in connection with the Products, their sale or use or these terms, shall be settled by arbitration conducted in accordance with the Center for Public Resources (CPR) Rules for Non-Administered Arbitration of International Disputes, by a sole arbitrator chosen from the CPR's panels of distinguished neutrals. Judgment upon the award rendered by the Arbitrator shall be final and binding and may be entered by any court having jurisdiction thereof. The place of the arbitration shall be New York City, New York. The language of the arbitration shall be English. The neutral organization designated to perform the functions specified in Rule 6 and Rules 7.7(b), 7.8 and 7.9 shall be the CPR.

· For Safety CPUs

Please confirm the following product warranty details before using this product.

1. Limited Warranty and Product Support.

- a. Mitsubishi Electric Company ("MELCO") warrants that for a period of eighteen (18) months after date of delivery from the point of manufacture or one year from date of Customer's purchase, whichever is less, Mitsubishi MELSEC Safety programmable logic controllers (the "Products") will be free from defects in material and workmanship.
- b. At MELCO's option, for those Products MELCO determines are not as warranted, MELCO shall either repair or replace them or issue a credit or return the purchase price paid for them.
- c. For this warranty to apply:
 - (1) Customer shall give MELCO (i) notice of a warranty claim to MELCO and the authorized dealer or distributor from whom the Products were purchased, (ii) the notice shall describe in reasonable details the warranty problem, (iii) the notice shall be provided promptly and in no event later than thirty (30) days after the Customer knows or has reason to believe that Products are not as warranted, and (iv) in any event, the notice must be given within the warranty period;
 - (2) Customer shall cooperate with MELCO and MELCO's representatives in MELCO's investigation of the warranty claim, including preserving evidence of the claim and its causes, meaningfully responding to MELCO's questions and investigation of the problem, grant MELCO access to witnesses, personnel, documents, physical evidence and records concerning the warranty problem, and allow MELCO to examine and test the Products in question onsite or at the premises where they are installed or used; and
 - (3) If MELCO requests, Customer shall remove Products it claims are defective and ship them to MELCO or MELCO's authorized representative for examination and, if found defective, for repair or replacement. The costs of removal, shipment to and from MELCO's designated examination point, and reinstallation of repaired or replaced Products shall be at Customer's expense.
 - (4) If Customer requests and MELCO agrees to effect repairs onsite at any domestic or overseas location, the Customer will pay for the costs of sending repair personnel and shipping parts. MELCO is not responsible for any re-commissioning, maintenance, or testing on-site that involves repairs or replacing of the Products.
- d. Repairs of Products located outside of Japan are accepted by MELCO's local authorized service facility centers ("FA Centers"). Terms and conditions on which each FA Center offers repair services for Products that are out of warranty or not covered by MELCO's limited warranty may vary.
- e. Subject to availability of spare parts, MELCO will offer Product repair services for (7) years after each Product model or line is discontinued, at MELCO's or its FA Centers' rates and charges and standard terms in effect at the time of repair. MELCO usually produces and retains sufficient spare parts for repairs of its Products for a period of seven (7) years after production is discontinued.
- f. MELCO generally announces discontinuation of Products through MELCO's Technical Bulletins. Products discontinued and repair parts for them may not be available after their production is discontinued.

2. Limits of Warranties.

- a. MELCO does not warrant or guarantee the design, specify, manufacture, construction or installation of the materials, construction criteria, functionality, use, properties or other characteristics of the equipment, systems, or production lines into which the Products may be incorporated, including any safety, fail-safe and shut down systems using the Products.
- b. MELCO is not responsible for determining the suitability of the Products for their intended purpose and use, including determining if the Products provide appropriate safety margins and redundancies for the applications, equipment or systems into which they are incorporated.
- c. Customer acknowledges that qualified and experienced personnel are required to determine the suitability, application, design, construction and proper installation and integration of the Products. MELCO does not supply such personnel.
- d. MELCO is not responsible for designing and conducting tests to determine that the Product functions appropriately and meets application standards and requirements as installed or incorporated into the end-user's equipment, production lines or systems.
- e. MELCO does not warrant any Product:
 - (1) repaired or altered by persons other than MELCO or its authorized engineers or FA Centers;
 - (2) subjected to negligence, carelessness, accident, misuse, or damage;
 - (3) improperly stored, handled, installed or maintained;
 - (4) integrated or used in connection with improperly designed, incompatible or defective hardware or software;
 - (5) that fails because consumable parts such as batteries, backlights, or fuses were not tested, serviced or replaced;
 - (6) operated or used with equipment, production lines or systems that do not meet applicable and commensurate legal, safety and industry-accepted standards;
 - (7) operated or used in abnormal applications;
 - (8) installed, operated or used in contravention of instructions, precautions or warnings contained in MELCO's user, instruction and/or safety manuals, technical bulletins and guidelines for the Products;
 - (9) used with obsolete technologies or technologies not fully tested and widely accepted and in use at the time of the Product's manufacture;
 - (10) subjected to excessive heat or moisture, abnormal voltages, shock, excessive vibration, physical damage or other improper environment; or
 - (11) damaged or malfunctioning due to Acts of God, fires, acts of vandals, criminals or terrorists, communication or power failures, or any other cause or failure that results from circumstances beyond MELCO's control.
- f. All Product information and specifications contained on MELCO's website and in catalogs, manuals, or technical information materials provided by MELCO are subject to change without prior notice.

- g. The Product information and statements contained on MELCO's website and in catalogs, manuals, technical bulletins or other materials provided by MELCO are provided as a guide for Customer's use. They do not constitute warranties and are not incorporated in the contract of sale for the Products.
- h. These terms and conditions constitute the entire agreement between Customer and MELCO with respect to warranties, remedies and damages and supersede any other understandings, whether written or oral, between the parties. Customer expressly acknowledges that any representations or statements made by MELCO or others concerning the Products outside these terms are not part of the basis of the bargain between the parties and are not factored into the pricing of the Products.
- i. THE WARRANTIES AND REMEDIES SET FORTH IN THESE TERMS ARE THE EXCLUSIVE AND ONLY WARRANTIES AND REMEDIES THAT APPLY TO THE PRODUCTS.
- j. MELCO DISCLAIMS THE IMPLIED WARRANTIES OF MERCHANTABILITY AND FITNESS FOR A PARTICULAR PURPOSE.

3. Limits on Damages.

- a. MELCO'S MAXIMUM CUMULATIVE LIABILITY BASED ON ANY CLAIMS FOR BREACH OF WARRANTY OR CONTRACT, NEGLIGENCE, STRICT TORT LIABILITY OR OTHER THEORIES OF RECOVERY REGARDING THE SALE, REPAIR, REPLACEMENT, DELIVERY, PERFORMANCE, CONDITION, SUITABILITY, COMPLIANCE, OR OTHER ASPECTS OF THE PRODUCTS OR THEIR SALE, INSTALLATION OR USE SHALL BE LIMITED TO THE PRICE PAID FOR PRODUCTS NOT AS WARRANTED.
- b. Although MELCO has obtained the certification for Product's compliance to the international safety standards IEC61508 and ISO13849-1 from TUV Rheinland, this fact does not guarantee that Product will be free from any malfunction or failure. The user of this Product shall comply with any and all applicable safety standard, regulation or law and take appropriate safety measures for the system in which the Product is installed or used and shall take the second or third safety measures other than the Product. MELCO is not liable for damages that could have been prevented by compliance with any applicable safety standard, regulation or law.
- c. MELCO prohibits the use of Products with or in any application involving power plants, trains, railway systems, airplanes, airline operations, other transportation systems, amusement equipments, hospitals, medical care, dialysis and life support facilities or equipment, incineration and fuel devices, handling of nuclear or hazardous materials or chemicals, mining and drilling, and other applications where the level of risk to human life, health or property are elevated.
- d. MELCO SHALL NOT BE LIABLE FOR SPECIAL, INCIDENTAL, CONSEQUENTIAL, INDIRECT OR PUNITIVE DAMAGES, FOR LOSS OF PROFITS, SALES, OR REVENUE, FOR INCREASED LABOR OR OVERHEAD COSTS, FOR DOWNTIME OR LOSS OF PRODUCTION, FOR COST OVERRUNS, OR FOR ENVIRONMENTAL OR POLLUTION DAMAGES OR CLEAN-UP COSTS, WHETHER THE LOSS IS BASED ON CLAIMS FOR BREACH OF CONTRACT OR WARRANTY, VIOLATION OF STATUTE, NEGLIGENCE OR OTHER TORT, STRICT LIABILITY OR OTHERWISE.
- e. In the event that any damages which are asserted against MELCO arising out of or relating to the Products or defects in them, consist of personal injury, wrongful death and/or physical property damages as well as damages of a pecuniary nature, the disclaimers and limitations contained in these terms shall apply to all three types of damages to the fullest extent permitted by law. If, however, the personal injury, wrongful death and/or physical property damages cannot be disclaimed or limited by law or public policy to the extent provided by these terms, then in any such event the disclaimer of and limitations on pecuniary or economic consequential and incidental damages shall nevertheless be enforceable to the fullest extent allowed by law.
- f. In no event shall any cause of action arising out of breach of warranty or otherwise concerning the Products be brought by Customer more than one year after the cause of action accrues.
- g. Each of the limitations on remedies and damages set forth in these terms is separate and independently enforceable, notwithstanding the unenforceability or failure of essential purpose of any warranty, undertaking, damage limitation, other provision of these terms or other terms comprising the contract of sale between Customer and MELCO.

4. Delivery/Force Majeure.

- a. Any delivery date for the Products acknowledged by MELCO is an estimated and not a promised date. MELCO will make all reasonable efforts to meet the delivery schedule set forth in Customer's order or the purchase contract but shall not be liable for failure to do so.
- b. Products stored at the request of Customer or because Customer refuses or delays shipment shall be at the risk and expense of Customer.
- c. MELCO shall not be liable for any damage to or loss of the Products or any delay in or failure to deliver, service, repair or replace the Products arising from shortage of raw materials, failure of suppliers to make timely delivery, labor difficulties of any kind, earthquake, fire, windstorm, flood, theft, criminal or terrorist acts, war, embargoes, governmental acts or rulings, loss or damage or delays in carriage, acts of God, vandals or any other circumstances reasonably beyond MELCO's control.

5. Choice of Law/Jurisdiction.

These terms and any agreement or contract between Customer and MELCO shall be governed by the laws of the State of New York without regard to conflicts of laws. To the extent any action or dispute is not arbitrated, the parties consent to the exclusive jurisdiction and venue of the federal and state courts located in the Southern District of the State of New York. Any judgment there obtained may be enforced in any court of competent jurisdiction.

6. Arbitration.

Any controversy or claim arising out of, or relating to or in connection with the Products, their sale or use or these terms, shall be settled by arbitration conducted in accordance with the Center for Public Resources (CPR) Rules for Non-Administered Arbitration of International Disputes, by a sole arbitrator chosen from the CPR's panels of distinguished neutrals. Judgment upon the award rendered by the Arbitrator shall be final and binding and may be entered by any court having jurisdiction thereof. The place of the arbitration shall be New York City, New York. The language of the arbitration shall be English. The neutral organization designated to perform the functions specified in Rule 6 and Rules 7.7(b), 7.8 and 7.9 shall be the CPR.

INFORMATION AND SERVICES

For further information and services, please contact your local Mitsubishi Electric sales office or representative.
Visit our website to find our locations worldwide.

MITSUBISHI ELECTRIC Factory Automation Global Website
Locations Worldwide
www.MitsubishiElectric.com/fa/about-us/overseas/

TRADEMARKS

CiA[®] and CANopen[®] are registered EU trademarks of CiA e. V.

DeviceNet is a trademark of ODVA, Inc.

PROFIBUS is a trademark of PROFIBUS Nutzerorganisation e.V.

QR Code is either a registered trademark or a trademark of DENSO WAVE INCORPORATED in the United States, Japan, and/or other countries.

The SD and SDHC logos are trademarks of SD-3C, LLC.

Microsoft and Windows are trademarks of the Microsoft group of companies.

The company names, system names and product names mentioned in this manual are either registered trademarks or trademarks of their respective companies.

In some cases, trademark symbols such as [™] or [®] are not specified in this manual.



TRANSLATION OF THE ORIGINAL INSTRUCTIONS

SH(NA)-081262ENG-AU(2510)MEE

MODEL: R-MK-E

MITSUBISHI ELECTRIC CORPORATION

HEAD OFFICE: TOKYO BLDG., 2-7-3, MARUNOUCHI, CHIYODA-KU, TOKYO 100-8310, JAPAN
NAGOYA WORKS: 1-14, YADA-MINAMI 5-CHOME, HIGASHI-KU, NAGOYA 461-8670, JAPAN

When exported from Japan, this manual does not require application to the
Ministry of Economy, Trade and Industry for service transaction permission.

Specifications subject to change without notice.