

## Paperless Recorder TR30 Series

### PAPERLESS RECORDER

#### Functions & Features

- Records measurement data and running / stopping status of device in an SD card
- Allows Web browsing of the recorded data
- Flexibly combined with R30 series I/O modules depending on required signal type and the number of points

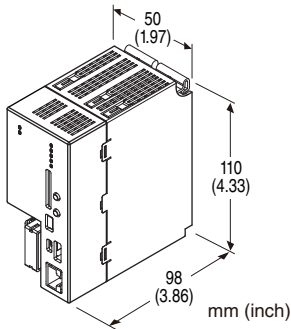

### MODEL: TR30-G-R[1]

#### ORDERING INFORMATION

- Code number: TR30-G-R[1]  
Specify a code from below for [1].  
(e.g. TR30-G-R/Q)
- Specify the specification for option code /Q  
(e.g. /C01)

#### MODULE TYPE

N: Standard

G: High functionality

#### POWER INPUT

##### DC power

R: 24 V DC

(Operational voltage range:  $\pm 10\%$ ; ripple 10 %p-p max.)

#### [1] OPTIONS

blank: none

/Q: With options (specify the specification)

#### SPECIFICATIONS OF OPTION: Q

**COATING (For the detail, refer to M-System's web site.)**

/C01: Silicone coating

/C02: Polyurethane coating

/C03: Rubber coating

#### FUNCTIONS & FEATURES

TR30 is used in combination with base (model: R30BS) and I/O modules (Remote I/O R30 series).

##### ■ TR30

Input data collection and recording, and output data transmission:

Collects data from I/O modules via internal bus and records the data in the internal memory, then in SD card;  
Connects with remote I/Os using Modbus/TCP via Ethernet, and collects and records input data of the remote I/Os;  
Connects with Mitsubishi programmable controller MELSEC using SLMP to collect and record data of the CPU of MELSEC; and

Transmits alarm output to Output module in accordance with the preset alarm level.

##### • Web server:

Works as a web server and displays collected data on the browser of a tablet. Various settings and operations can be done from the tablet.

##### • Internal power

Internal power required for TR30 and I/O modules is generated from supplied power.

##### ■ I/O Module

Outputs data received through the internal bus as discrete outputs; and outputs discrete input data and A/D converted analog input values to the internal bus. (Refer to the specification of each R30 I/O module for details)

##### ■ Installation base

The base for installation of modules incorporates PWB for internal power and internal bus. (Refer to the specification of installation base (model: R30BS))

#### RELATED PRODUCTS

- Remote I/O R30 series
- PC Configurator cable  
USB 2.0 compatible cable  
(TR30 connector: mini-B type, 5.0m max.)

- PC configurator software (model: TRGCFG)
- PC configurator software (model: R30CFG)
- Viewer software (model: TRViewer)

Software downloadable at M-System's web site.

- SD card

An SD card is required to store data in the unit.

Use a memory card of the specified model number.

Consult M-System for purchase.

- Hagiwara Solutions NSD6-004GH, NSD6-016GH

## GENERAL SPECIFICATIONS

### Connection

**RUN contact output, power supply:** M3 separable screw terminal (torque 0.5 N·m)

**Ethernet:** RJ-45 modular jack

**Internal bus:** Via the Installation Base (model: R30BS)

**Internal power:** Via the Installation Base (model: R30BS)

**Solderless terminal:** Refer to the drawing at the end of the section.

**Recommended manufacturer:** Japan Solderless Terminal MFG. Co., Ltd., Nichifu Co., Ltd.

(Solderless terminals with insulation sleeve do not fit.)

**Applicable wire size:** 0.25 to 0.75 mm<sup>2</sup>

**Screw terminal:** Nickel-plated steel

**Housing material:** Flame-resistant resin (gray)

**Max. number of R30 I/O modules:** 16

(Max. consumption current of I/O modules: 500 mA)

**Isolation:** Ethernet to internal bus or internal power to RUN contact output to power supply to FE

**Calendar clock:** Year (4 digits), month, date, day, hour, minute, second

**Read rate:** Approx.  $\leq 1$  msec. (Connected max. modules)

**Indicator LEDs:** PWR, TR30 RUN, RECORD, SD CARD, ERROR (Refer to the instruction manual)

### ■ RUN CONTACT OUTPUT

**RUN contact output:** Turns on (closed) at normal operation

**Rated load:** 250 V AC @ 0.5 A ( $\cos \phi = 1$ )

30 V DC @ 0.5 A (resistive load)

(Less than 50 V AC to conform with EU Directive)

**Maximum switching voltage:** 250 V AC or 30 V DC

**Maximum switching power:** 250 VA (AC) or 30 W (DC)

**Minimum load:** 5 V DC @ 10 mA

**Mechanical life:**  $2 \times 10^7$  cycles (rate 300 cycles/min.) When driving an inductive load, external contact protection and noise quenching recommended.

**■ Recommended solderless terminal size - M3 (unit: mm)**

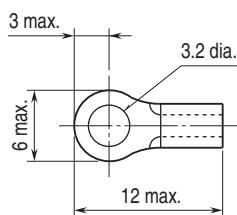

## R30 CONNECTION

### ■ TR30 INSTALL POSITION

Install to PWR slot (most left slot) and COM slot (right next to PWR slot).

### ■ COMPATIBLE R30 SERIES MODULES

TYPE	MODEL
Base	R30BS
Discrete input	R30XN16A
Discrete output	R30YN16A, R30YN16C
DC voltage/current input	R30SV2, R30SV4
DC voltage/current input, high speed	R30SVF4
Thermocouple input	R30TS4
RTD input	R30RS4
Potentiometer input	R30MS4
AC current input	R30CT4E
Universal input	R30US2, R30US4
Totalized pulse input	R30PA2
Blank filler	R30DM

## ETHERNET COMMUNICATION

**Communication Standard:** IEEE 802.3u

**Transmission:** 10BASE-T, 100BASE-TX

**Baud rate:** 10/100 Mbps (Auto Negotiation function)

**Protocol:** TCP/IP, Modbus/TCP, HTTP, SLMP, FTP, SMTP, SNTP

**Transmission media:** 10BASE-T (STP, Category 5) 100BASE-TX (STP, Category 5e)

**Max. length of fieldbus segment:** 100 meters

**Ethernet indicator LED:** DPX, LNK

**IP address:** 192.168.0.1 (factory setting)

## INSTALLATION

### Power consumption

• **DC:** Approx. 18 W 24 V DC (@ output current max. 500 mA)

### Internal power

• **Max. rated output voltage / current:** 21 V DC / 500 mA

Total current consumed at the R30 I/O modules used combination with TR30 must be within above current.

**Operating temperature:** 0 to 50°C (32 to 122°F)

**Storage temperature:** -10 to +60°C (14 to +140°F)

**Operating humidity:** 10 to 90 %RH (non-condensing)

**Atmosphere:** No corrosive gas or heavy dust

**Mounting:** Installation Base (model: R30BS)

**Weight:** 300 g (0.66 lb)

## PERFORMANCE

- Calendar clock:** (with battery backup)
- Accuracy:** Monthly deviation 2 minutes at 25°C
- Back up period:** Approx. 2 years at 25°C
- Battery:** Primary lithium battery (non-removable)  
(In order to prevent battery drain, battery back up is OFF at factory default. Turn it ON prior to start using.)
- Insulation resistance:**  $\geq 100 \text{ M}\Omega$  with 500 V DC
- Dielectric strength:** 1500 V AC @ 1 minute  
(Ethernet to internal bus or internal power to RUN contact output to power supply to FE)

## STANDARDS & APPROVALS

### EU conformity:

- EMC Directive
- EMI EN 61000-6-4
- EMS EN 61000-6-2
- RoHS Directive
- EN 50581

## EXTERNAL VIEW

### FRONT VIEW

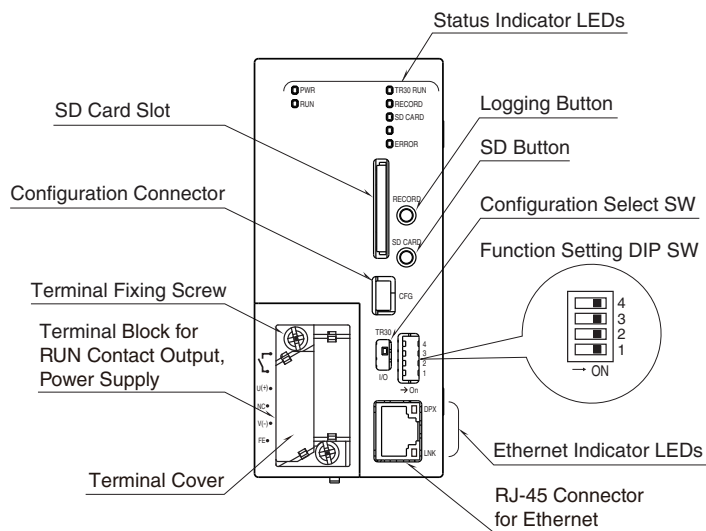

### SIDE VIEW

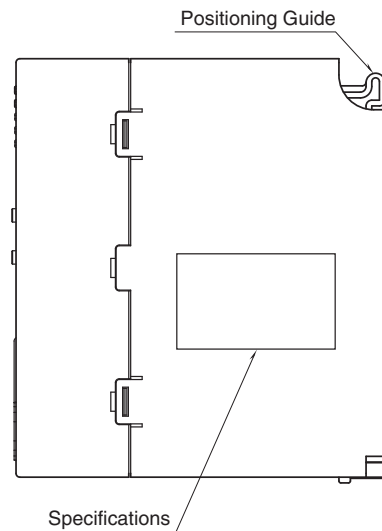

### BOTTOM VIEW

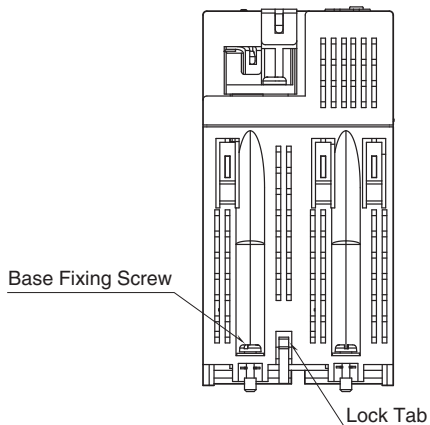

**TERMINAL ASSIGNMENTS**

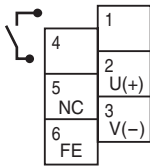

NO.	ID	FUNCTON
1	RUN contact output	RUN contact output
2	U (+)	Power supply (24 V DC)
3	V (-)	Power supply (0 V DC)
4	RUN contact output	RUN contact output
5	NC	Not used
6	FE	Functional earth

**EXTERNAL DIMENSIONS unit: mm (inch)**

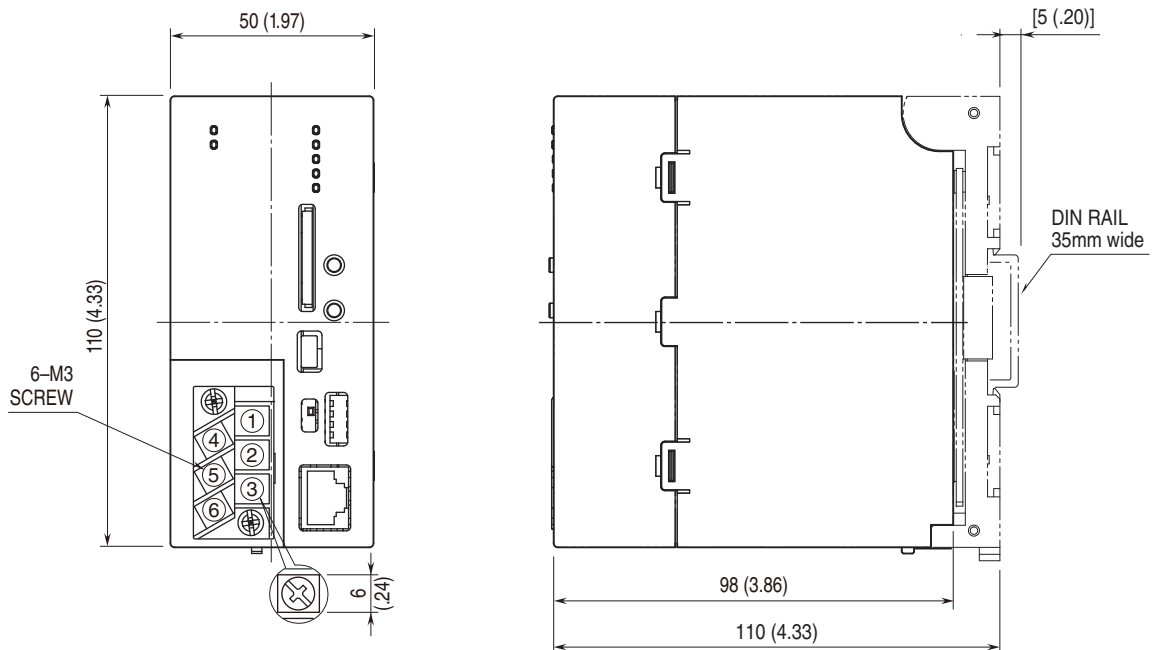

## SCHEMATIC CIRCUITRY & CONNECTION DIAGRAM

Note: In order to improve EMC performance, bond the FE terminal to ground.

Caution: FE terminal is NOT a protective conductor terminal.

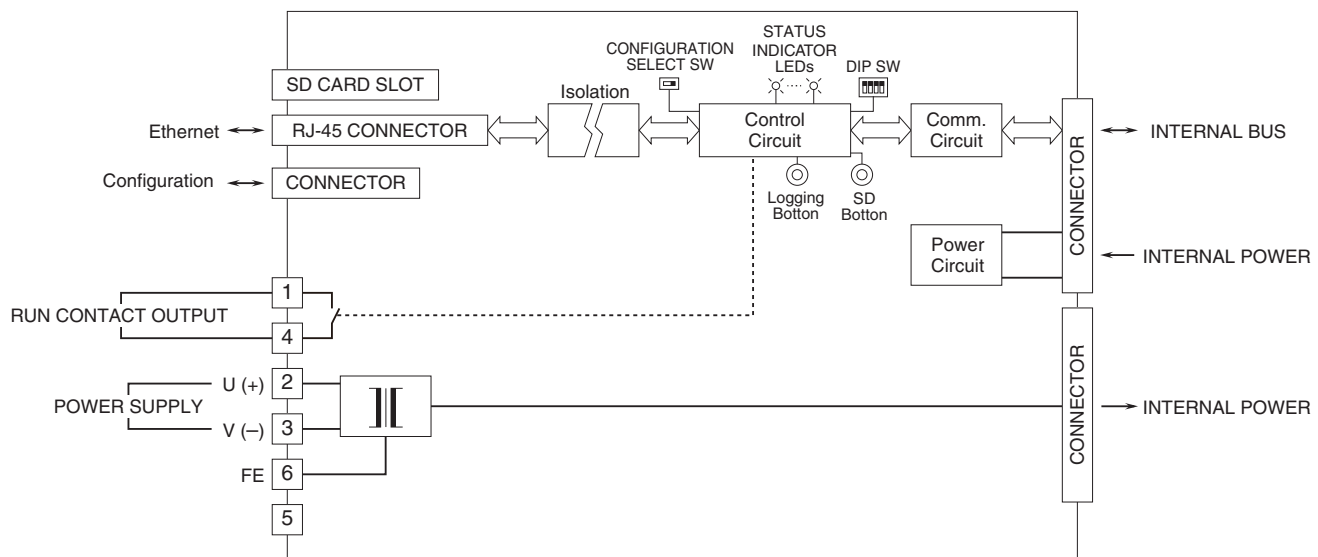

## DATA STORING

The trend data, event data and comment data are stored into the internal memory with specified storing rate. It is available to transfer into the SD card with the timing according to the storing rate.

### ■ Event data

- Event: Transition of analog input zone, transition of pulse input zone, status change of discrete input
- Event detection interval: Same as trend data sampling cycle
- Stored contents: Date/time, event
- Number of event: 3000 (per one memory block)

### ■ Comment data

- Number of characters for comment: 32
- Stored contents: Date/time, comment.
- Number of comment: 1000 (per one memory block)

### ■ Trend data

- Channel: Max. 120 points (Choose among followings: analog input (AI), discrete input (DI), pulse input (PI), function input (OI), discrete output (DO))
- Number of records: 50 memory blocks  
Save maximum 50000 samples per one block

STORING RATE	SAMPLING CYCLE	PEN	AI	DI	PI	OI	DO
5 ms	5 ms	16	16	32	16	16	32
10 ms	5 ms	16	16	32	16	16	32
50 ms	5 ms	16	16	32	16	16	32
100 ms	100 ms	32	32	64	32	32	64
500 ms	100 ms	32	32	64	32	32	64
1 sec.	100 ms	32	32	64	32	32	64
2 sec.	1 sec.	32	32	64	32	32	64
5 sec.	1 sec.	32	32	64	32	32	64
10 sec.	1 sec.	32	32	64	32	32	64
1 min.	1 sec.	120	64	64	32	32	64
2 min.	1 sec.	120	64	64	32	32	64
5 min.	1 sec.	120	64	64	32	32	64
10 min.	1 sec.	120	64	64	32	32	64
15 min.	1 sec.	120	64	64	32	32	64
30 min.	1 sec.	120	64	64	32	32	64
1 hour	1 sec.	120	64	64	32	32	64

## ■ SD card

- Recording contents: Trend data, event data, comment data, settings information

STORING RATE	TRANSFER INTERVAL
5 ms	3 min.
10 ms	5 min.
50 ms	10 min., 30 min.
100 ms	10 min., 30 min., 1 hour
500 ms	30 min., 1 hour, 6 hours
1 sec.	1 hour, 6 hours, 12 hours
2 sec.	1 hour, 6 hours, 1 day
5 sec.	6 hours, 12 hours, 1 day
10 sec.	6 hours, 12 hours, 1 day
1 min.	1 day, 1 week
2 min.	1 day, 1 week
5 min.	1 day, 1 week, 1 month
10 min.	1 day, 1 week, 1 month
15 min.	1 day, 1 week, 1 month
30 min.	1 day, 1 week, 1 month
1 hour	1 week, 1 month

Note: Defining no specification of interval (50000 points) is available for all storing rate.

## • Data format

Trend data, event data and comment data are saved with dedicated format (binary, extension "TRD") or CSV format. Setting information is saved into text format (xml format, extension "xml").

## • Data file name

File name is created with YYYYMMDDHHMMSS and daylight saving time (S or D) in the beginning of sample. (e.g. 20140212100000S.TRD)

## • Viewer Software

The data transferred to SD card can be displayed with using dedicated Viewer Software (model: TRViewer). Also, data can be converted to CSV format file.

## • Auto file delete

When auto file delete is disabled, data are recorded until there is no remaining space in the SD card. When auto file delete is enabled and the remaining space in the SD card reaches 100MB or less, the data is deleted from the oldest.

## • Storable time duration

(rough guide for 4GB SD card "TRD")

STORING RATE	16 pens	32 pens	64 pens	120 pens
5 ms	3 days			
10 ms	6 days			
50 ms	25 days			
100 ms	50 days	30 days		
500 ms	8 months	4 months		
1 sec.	1 year	9 months		
2 sec.	2 years	1 year		
5 sec.	7 years	4 years		
10 sec.	10 years	7.5 years		
1 min. – 1 hour	10 years (max. 10 years)			

Note: When only trend logging is enabled.

## • Storable time duration

(rough guide for 4GB SD card "CSV")

STORING RATE	16 pens	32 pens	64 pens	120 pens
5 ms	34 hours			
10 ms	69 hours			
50 ms	14 days			
100 ms	28 days	15 days		
500 ms	4 months	78 days		
1 sec.	9 months	5 months		
2 sec.	1.5 years	10 months		
5 sec.	3.5 years	2 years		
10 sec.	7 years	4 years		
1 min. – 1 hour	10 years (max. 10 years)			

Note: When only trend logging is enabled.

## COMMUNICATION

### ■ IP

Supports DHCP client. Allows manual setting of IP address, subnet mask, default gateway and DNS server.

### ■ Web server function

This unit works as a Web server, and allows 'Data,' 'Trend' and 'Event Log' to be viewed from a remote location.

Compatible terminals, browser

- iPad (iOS 10.2): Safari
- Android tablet (Android 6.0): Chrome 56.0.2924.87
- Windows PC (Windows 7, 8.1, 10), Tablet (Windows 8.1, 10): Edge, Internet Explorer 11, Firefox 52.0, Chrome 57.0.2987.98

### ■ Modbus/TCP master

Allows I/O expansion with remote I/Os such as R3 or R7 series. Collectively handles data from measuring points in multiple locations.

### ■ Connectable devices

- R3-NE1
- R5-NE1
- R6-NE1, R6-NE2
- R7E series
- R9EWTU
- 72EM2-M4
- GR8-EM
- DL8 series
- TR3EX
- IT series
- 73VR series

### ■ SLMP Client

Allows I/O expansion by connecting with the SLMP-compatible CPU unit of Mitsubishi programmable controller MELSEC. Collectively handles data from measuring points in multiple locations

### ■ Connectable MELSEC model

- MELSEC iQ-R series
- MELSEC iQ-F series
- MELSEC Q series

■ **Max. number of connectable devices**  
(Number of slaves)

- 12 (nodes) (selectable between Modbus/TCP and SLMP)
- Establishes connection for the number of slaves connected.

■ **Max. I/O points**

- **Analog input:** 64 points
- **Discrete input:** 64 points
- **Pulse input:** 32 points
- **Discrete output:** 64 points

■ **Modbus/TCP slave**

Remotely monitored with SCADA. Operations such as recording start/stop, entering comment, specifying folder/file name for SD card transfer destination and setting folder name for ftp transfer destination are possible from PLC.

## ALARM OUTPUT

DO designated as alarm contact output can be turned ON at event occurrence.

## EVENT REPORTING E-MAIL

Reporting e-mail function available at event or designated time.

Encrypted communication is supported. (SMTP over SSL). The TR30 turns a designated Do ON after transmitting the report.

- Number of e-mail attention: 32
- Number of event report text: 32
- Number of regular report text: 1
- Channel status: AI, DI, PI, OI, DO status attachable to e-mail
- Output at transmitting failure: 1 point

## FTP CLIENT

It is available to upload the file saved in the SD card to FTP server.

STORING RATE	TRANSFER INTERVAL
5 ms	3 min.
10 ms	5 min.
50 ms	10 min., 30 min.
100 ms	10 min., 30 min., 1 hour
500 ms	30 min., 1 hour, 6 hours
1 sec.	1 hour, 6 hours, 12 hours
2 sec.	1 hour, 6 hours, 1 day
5 sec.	6 hours, 12 hours, 1 day
10 sec.	6 hours, 12 hours, 1 day
1 min.	1 day, 1 week
2 min.	1 day, 1 week
5 min.	1 day, 1 week, 1 month
10 min.	1 day, 1 week, 1 month
15 min.	1 day, 1 week, 1 month
30 min.	1 day, 1 week, 1 month
1 hour	1 week, 1 month

Note: If interval is maximum, the data is transferred at the time when 50000 points is stored.

## FTP SERVER

Reading and deleting files in the SD card by an FTP client is available.

Operation verified FTP client

- Explorer
- Web browser
- Internet Explorer version 11
- Firefox version 52.0 or later
- Chrome 57.0.2987.98
- FFFTP 1.98g

## ARITHMETIC FUNCTION

Addition and subtraction, multiplication, division, square root, moving average, delay buffer, exp, common logarithm, natural logarithm, peak hold(max/min), analog accumulation, power, F value calculation, inverse logarithm and scaling are available with function input (OI).

## OTHER FUNCTIONS

Configuration: Configurable with the dedicated software model: TRGCFG

## SYSTEM CONFIGURATION EXAMPLES

Devices other than the TR30 in below provided by the user.

### ■ VIA LOCAL NETWORK (LAN)

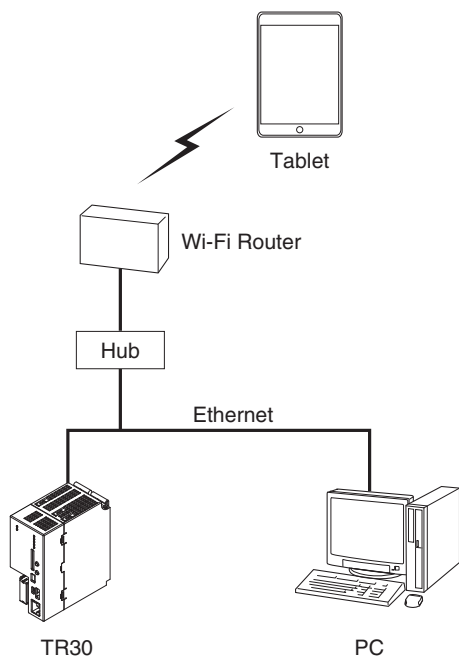

### ■ VIA INTERNET (WAN)

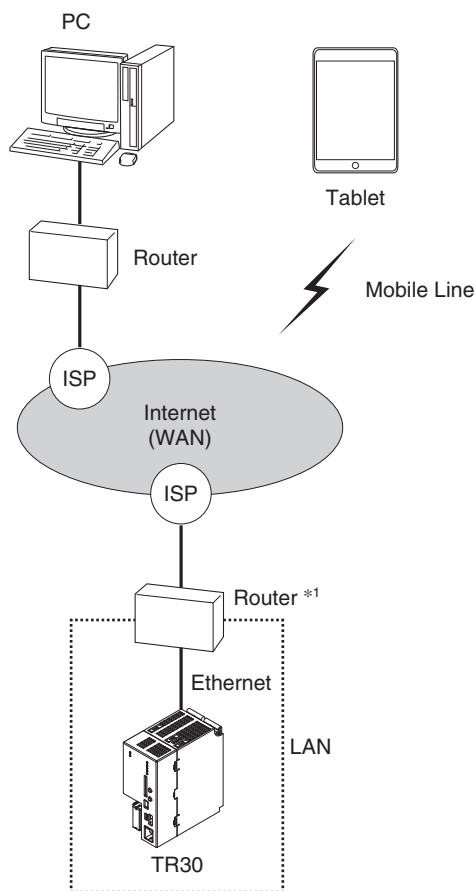

\*1. D.DNS service or static IP address is required.

### ■ STAND-ALONE

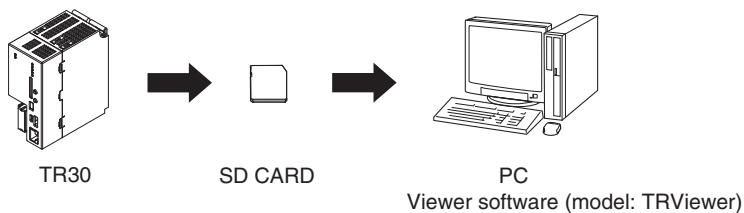

Note: Data storing to SD card is performed at every transfer interval.



Specifications are subject to change without notice.