

ETHERNET INTERFACE MODULE
(Modbus/TCP, use with TR30)

MODEL **TR3EX**

BEFORE USE

Thank you for choosing M-System. Before use, please check contents of the package you received as outlined below. If you have any problems or questions with the product, please contact M-System's Sales Office or representatives.

■ PACKAGE INCLUDES:

Network interface module.....(1)

■ MODEL NO.

Confirm that the model number described on the product is exactly what you ordered.

■ INSTRUCTION MANUAL

This manual describes necessary points of caution when you use this product, including installation, connection and basic maintenance procedures.

POINTS OF CAUTION

■ CONFORMITY WITH EU DIRECTIVES

- The equipment must be mounted inside the instrument panel of a metal enclosure.
- The actual installation environments such as panel configurations, connected devices and connected wires may affect the protection level of this unit when it is integrated in a panel system. The user may have to review the CE requirements in regard to the whole system and employ additional protective measures to ensure CE conformity.

■ POWER INPUT RATINGS

- Operational range & power consumption: Check the power rating for the unit on the specification label.
Rating 24V DC: 24V ±10%, approx. 12W

■ UNPLUGGING THE MODULE

- Before you remove the module from its base or mount it, turn off the power supply for safety.

■ ENVIRONMENT

- Indoor use.
- When heavy dust or metal particles are present in the air, install the unit inside proper housing with sufficient ventilation.
- Do not install the unit where it is subjected to continuous vibration. Do not subject the unit to physical impact.
- Environmental temperature must be within -10 to +55°C (14 to 131°F) with relative humidity within 30 to 90% RH in order to ensure adequate life span and operation.

■ WIRING

- Do not install cables close to noise sources (relay drive cable, high frequency line, etc.).
- Do not bind these cables together with those in which noises are present. Do not install them in the same duct.

■ AND

- The unit is designed to function as soon as power is supplied, however, a warm up for 10 minutes is required for satisfying complete performance described in the data sheet.

INSTALLATION

Use the Installation Base Model R3-BSx, or Model R3-BSWx for free I/O address capability.

Before mounting the Network Interface Module onto the Base, be sure to configure the module as explained below.

■ DATA ALLOCATION

The setting determines the data area size assigned to each I/O module mounted on the base. The data sent/received via Modbus is mapped according to this setting. See "COMPONENT IDENTIFICATION."

■ NODE ADDRESS

See "COMPONENT IDENTIFICATION."

■ NETWORK SLOTS ON THE BASE

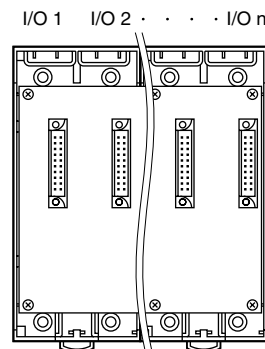

With Model R3-BSx base, mount the I/O Modules from the left end (I/O 1) to the right in order that the Network Module assigns data areas from I/O 1.

Network Module is mounted basically at the right end though technically they could be mounted in any position.

With Model R3-BSWx base, there is no limitation in mounting positions as I/O address can be assigned freely to each module using rotary switches equipped on the base.

COMPONENT IDENTIFICATION

FRONT VIEW

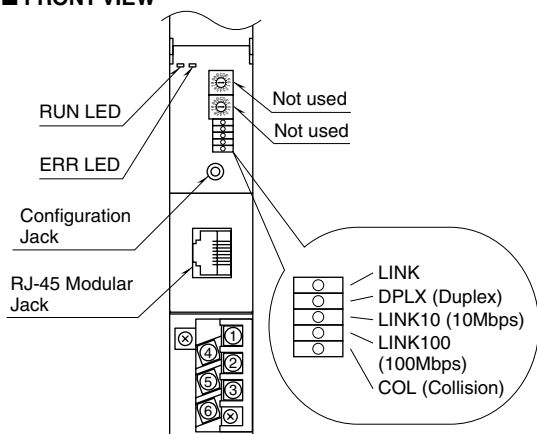

SIDE VIEW

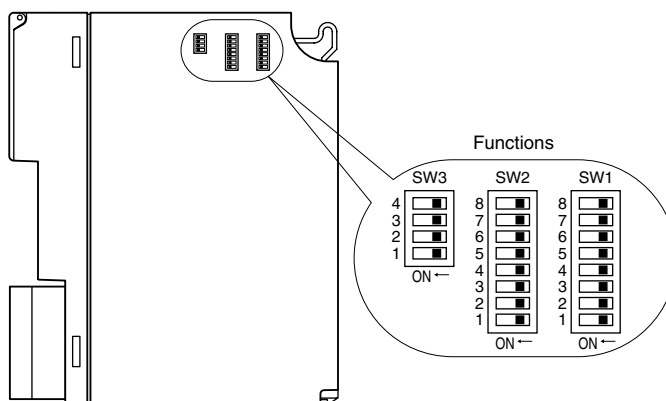

ETHERNET INDICATORS

ID	COLOR	FUNCTION
LINK	Red	ON at LINK
DPLX	Red	ON with full-duplex communication
LINK10	Red	ON with 10 Mbps connection
LINK100	Red	ON with 100 Mbps connection
COL	Red	Blinking when collision occurs

SIDE DIP SW

(*) Factory setting

Data Allocation: SW1, SW2

Data Allocation Type* must be assigned to each I/O module position to specify how many data areas (four types) are to be occupied by each.

Two bits from SW1 and SW2 are assigned to each position, and data areas can be specified from the module No. 1 through 8. Setting for No. 9 and later modules is identical to No. 8.

SW ASSIGNMENT		MODULE NO.
SW1-1	SW1-2	1
SW1-3	SW1-4	2
SW1-5	SW1-6	3
SW1-7	SW1-8	4
SW2-1	SW2-2	5
SW2-3	SW2-4	6
SW2-5	SW2-6	7
SW2-7	SW2-8	8
SW SETTING		DATA ALLOCATION
OFF	OFF	1
ON	OFF	4
OFF	ON	8
ON	ON	16

*Refer to the specifications of the related series for the Data Allocation Type of I/O modules.

Dual Communication: SW3-1

When two network modules are mounted, one must be 'Main' (OFF) network and the other must be 'Sub' (ON) network. For single communication, the network module must always be set to 'Main' (OFF).

SW	DUAL COMMUNICATION	
	MAIN (*)	SUB
SW3-1	OFF	ON

Input Error Data: SW3-2

Hold: When the communication from an input module is lost due to the input module error, the network module holds the signal and stands by until the communication recovers.

Set to '0': When the communication from an input module is lost due to the input module error, the network module outputs '0.'

SW	INPUT ERROR DATA	
	HOLD (*)	SET '0'
SW3-2	OFF	ON

LED Function: SW3-4

Functions assigned to the front RUN and ERR LEDs can be selected.

SW3-4	LED	
	RUN	ERR
OFF (*)	Green when normal	Green when abnormal
ON	Red when receiving	Red when transmitting

Note: Be sure to set unused SW3-3 to OFF

TERMINAL CONNECTIONS

Connect the unit as in the diagram below.

■ DIMENSIONS mm (inch)

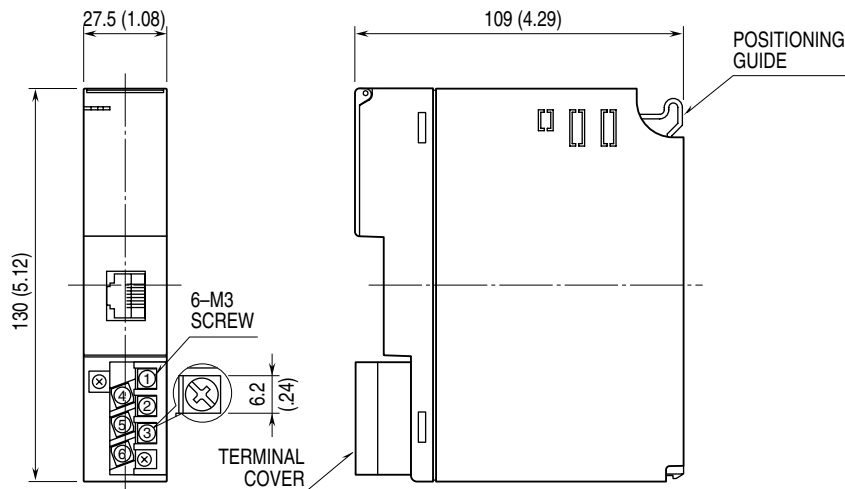

■ CONNECTION DIAGRAM

In order to improve EMC performance, bond the FG terminal to ground.
Caution: This terminal is NOT a protective conductor terminal.

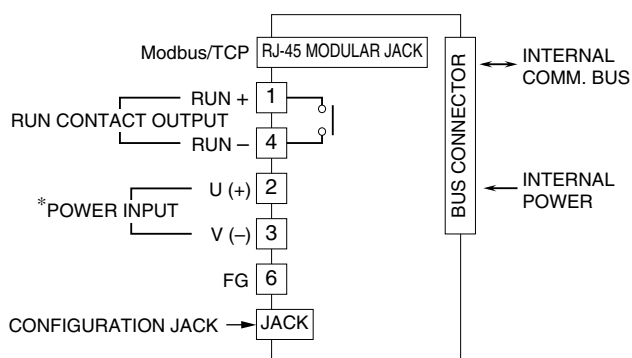

* Not provided with 'No Power Supply' type module.

WIRING INSTRUCTIONS

■ SCREW TERMINAL

Torque: 0.5 N·m

■ SOLDERLESS TERMINAL mm (inch)

Refer to the drawing below for recommended ring tongue terminal size. Spade tongue type is also applicable. Solderless terminals with insulation sleeve do not fit.

Applicable wire size: 0.75 – 1.25 mm²

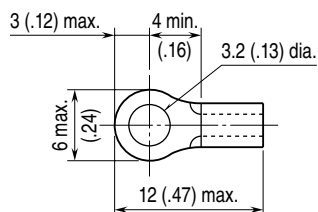

SETTING & CHECKING

1) IP ADDRESS

The R3-NE1 does not support BootP Table Software. The IP Address can be configured by using the R3CON Configurator Software.

The Modbus/TCP Port No. is fixed to 502.

2) DATA ALLOCATION

Data Allocation Type must be assigned to each I/O module position to specify how many data areas (four types) are to be occupied by each.

Two bits from SW1 and SW2 are assigned to each position on the base.

3) CHECK WIRING

Connect an Ethernet cable to the front RJ-45 jack.

4) CHECK LED

When wiring is correct, LINK and LINK10, or LINK and LINK100 are turned on.

When the module is receiving or sending data, LINK10 or LINK100 blinks.*

* For firmware version V3.00 or later, LED turns ON.

5) CHECK R3-GE1 CONNECTION

Enter "ping command" on the Windows MS-DOS as follows:

```
C:\WINDOWS>ping ***.***.***.***
(***.***.***.***: Enter IP address in decimal.)

ping ***.***.***.*** with 32 bytes of data:
Reply from ***.***.***.*** : bytes=32 time<10ms TTL=64
Reply from ***.***.***.*** : bytes=32 time<10ms TTL=64
Reply from ***.***.***.*** : bytes=32 time<10ms TTL=64
Reply from ***.***.***.*** : bytes=32 time<10ms TTL=64

Ping statistics for ***.***.***.***
    Packets: Sent=4, Received=4, Lost=0 (0% loss)
```

Replies in case of normal connection are as shown above. If the connection cannot be established normally due to e.g. wrong IP address, other replies such as "time over" will be received.

6) CHECK CONNECTION TO THE APPLICATION SOFTWARE

Check Point 1: LINK LEDs

When a normal connection is established, the front LINK and LINK10 or LINK100 are turned on regardless of data sending/receiving status. Check power supply to the hub in case that these LEDs are not on.

Check Point 2: RUN Indicator LED

With the side DIP SW3-4 is set to OFF, the RUN Indicator LED turns to Green in normal data sending/receiving.

Check Point 3: Sending/Receiving Indicators

With the side DIP SW3-4 is set to ON, the RUN Indicator LED turns to Red in data receiving, and the ERR Indicator LED turns to Green in data sending. In normal operating conditions, these LEDs may seem to flash at once due to the high speed transmission.

MODBUS I/O ASSIGNMENTS

	ADDRESS	DATA TYPE	DATA
Coil (0X)	1 – 1024		Digital Output (discrete output)
	1 – 1024		Digital Input (discrete input)
Inputs (1X)	1025 – 1040		Module Status
	1041 – 1056		Error Status
	1057 – 1072		Data Error Status
Input Registers (3X)	1 – 256	I	Analog Input
	257 – 768	F	Analog Input
Holding Registers (4X)	1 – 256	I	Analog Output
	257 – 768	F	Analog Output

I: Integer, 0 – 10000 (0 – 100%)

F: Floating (32-bit data cannot be accessed using floating addresses.)

Note: DO NOT access addresses other than mentioned above. Such access may cause problems such as inadequate operation.

- Module Status indicates whether individual I/O module are mounted or not. The bit corresponding to the mounted slots turns to “1”, and the unmounted slots to “0”.
- Error Status indicates error status for each module as described below. The bit corresponding to such modules turns to “1”.
R3-TSx, R3-RSx, R3-US4: Input burnout
R3-DA16A: Power input in error or disconnected
R3-YSx: Output current error (e.g. load unconnected)
- Data Error Status indicates overrange (R3-US4: out of -10% to +110%; the other types: out of -15% to +115%) status for each module. The bit corresponding to such modules turns to “1”.

TRANSMISSION DATA ASSIGNMENTS

The DIP SW located at the side of the module specifies each I/O module's data allocation (occupied data area).

For example, when the data areas are assigned as shown below:

Module 1	4
Module 2	4
Module 3	4
Module 4	1
Module 5	1
Module 6	1
Module 7	1

Then the I/O data are assigned as in the table below:

	ADDRESS	POSITION
Input Registers (3X) Holding Registers (4X)	1 – 4, 257 – 264	Slot 1
	5 – 8, 265 – 272	Slot 2
	9 – 12, 273 – 280	Slot 3
	13, 281 – 282	Slot 4
	14, 283 – 284	Slot 5
	15, 285 – 286	Slot 6
	16, 287 – 288	Slot 7

	ADDRESS	POSITION
Coil (0X) Inputs (1X)	1 – 64	Slot 1
	65 – 128	Slot 2
	129 – 192	Slot 3
	193 – 208	Slot 4
	209 – 224	Slot 5
	225 – 240	Slot 6
	241 – 256	Slot 7

For Coil (0X) and Inputs (1X), addresses 16 times assigned data areas (Data Allocation Type) are allotted with the Data Allocation Type '1' and '4'. With '8' and '16', 64 (4 × 16) are automatically assigned.

MODULE STATUS, ERROR STATUS, DATA ERROR STATUS

Shows each module's availability and error status.

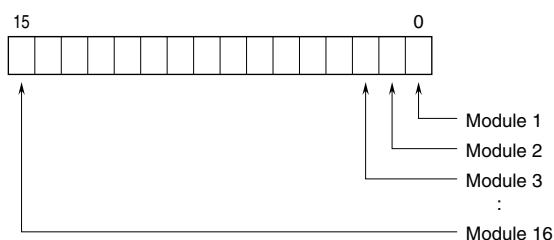

I/O DATA DESCRIPTIONS

The data allocations for typical I/O modules are shown below.
Refer to the manual for each module for detailed data allocations.

■ ANALOG DATA (models: R3-SV4, YV4, DS4, YS4 and US4, etc.)

16-bit binary data.

Basically, 0 to 100% of the selected I/O range is converted into 0 to 10000 (binary). Negative percentage is represented in 2's complements.

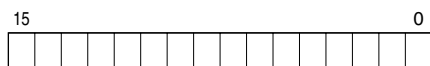

■ TEMPERATURE DATA (models: R3-RS4, TS4 and US4, etc.)

16-bit binary data.

With °C temperature unit, raw data is multiplied by 10. For example, 25.5°C is converted into 255.

With °F temperature unit, the integer section of raw data is directly converted into the data. For example, 135.4°F is converted into 135.

Minus temperature is converted into negative values, represented in 2's complements.



■ ACCUMULATED COUNT DATA (32-bit data, models: R3-PA2, PA4A, WT1, WT4, etc.)

32-bit binary data is used for accumulated counts and encoder positions.

Lower 16 bits are allocated from the lowest address to higher ones, higher 16 bits in turn.

32-bit data cannot be accessed using floating addresses.



■ BCD DATA (32-bit data, models: R3-BA32A, BC32A, etc.)

32-bit binary data is used for BCD.

Lower 16 bits are allocated from the lowest address to higher ones, higher 16 bits in turn.

32-bit data cannot be accessed using floating addresses.



■ DISCRETE DATA (models: R3-DA16, DC16 and RR8, etc.)

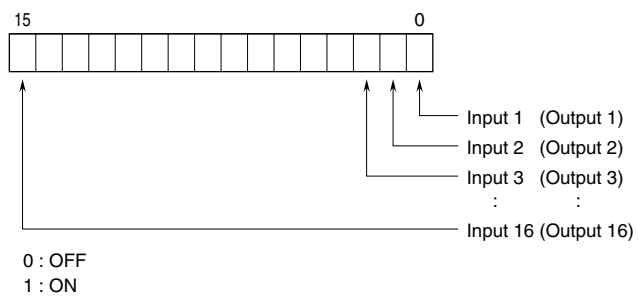

Regarding detailed data assignment of R3-RR8, refer to the instruction manual for R3-RR8 (EM-8432).