

PULSE ISOLATOR	MODEL M6SPP
-----------------------	--------------------

BEFORE USE

Thank you for choosing us. Before use, please check contents of the package you received as outlined below. If you have any problems or questions with the product, please contact our sales office or representatives.

■ PACKAGE INCLUDES:

Signal conditioner(1)

■ MODEL NO.

Confirm Model No. marking on the product to be exactly what you ordered.

■ INSTRUCTION MANUAL

This manual describes necessary points of caution when you use this product, including installation, connection and basic maintenance procedures.

POINTS OF CAUTION

■ CONFORMITY WITH EU DIRECTIVES

- The equipment must be mounted inside a panel.
- The actual installation environments such as panel configurations, connected devices, connected wires, may affect the protection level of this unit when it is integrated in a panel system. The user may have to review the CE requirements in regard to the whole system and employ additional protective measures to ensure the CE conformity.
- Install lightning surge protectors for those wires connected to remote locations.

■ POWER INPUT RATING & OPERATIONAL RANGE

- Locate the power input rating marked on the product and confirm its operational range as indicated below:
24V DC rating: 24V ±10%, approx. 1W

■ GENERAL PRECAUTIONS

- Before you remove the unit or mount it, turn off the power supply and input signal for safety.

■ ENVIRONMENT

- Indoor use.
- When heavy dust or metal particles are present in the air, install the unit inside proper housing with sufficient ventilation.
- Do not install the unit where it is subjected to continuous vibration. Do not subject the unit to physical impact.
- Environmental temperature must be within -20 to +55°C (-4 to +131°F) with relative humidity within 30 to 90% RH in order to ensure adequate life span and operation.

■ WIRING

- Do not install cables close to noise sources (relay drive cable, high frequency line, etc.).
- Do not bind these cables together with those in which noises are present. Do not install them in the same duct.

■ AND

- The unit is designed to function as soon as power is supplied, however, a warm up for 10 minutes is required for satisfying complete performance described in the data sheet.

COMPONENT IDENTIFICATION

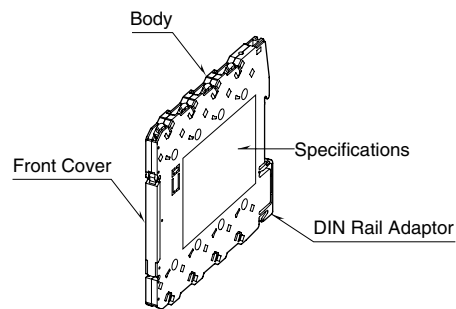

■ FRONT VIEW (with the cover open)

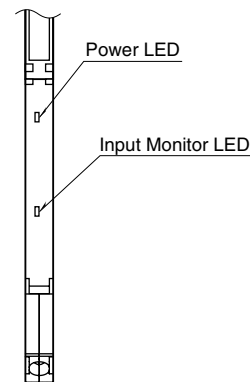

INSTALLATION

Set the unit so that its DIN rail adapter is at the bottom. When the unit is installed to an Installation Base (model M6SBS), refer to its instruction manual.

■ MOUNTING THE UNIT ON A DIN RAIL

- Hang the upper hook at the rear side of unit on the DIN rail.
- Push in the lower in keeping pressing the unit to the DIN rail.

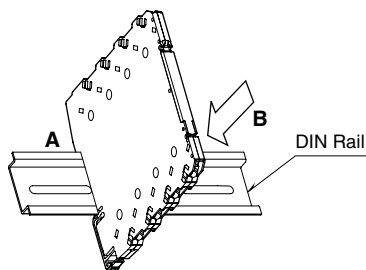

■ REMOVING THE UNIT

- Pull down the DIN rail adaptor using a minus screwdriver.
- Pull out the lower part of the unit.
- Remove the upper part from the DIN rail.

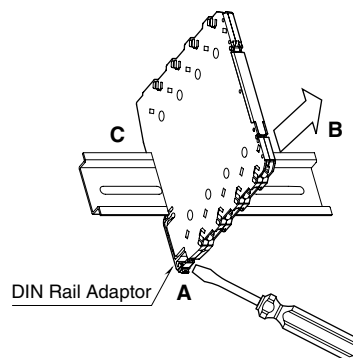

TERMINAL CONNECTIONS

Connect the unit as in the diagram below or refer to the connection diagram on the side of the unit.

■ EXTERNAL DIMENSIONS unit: mm (inch)

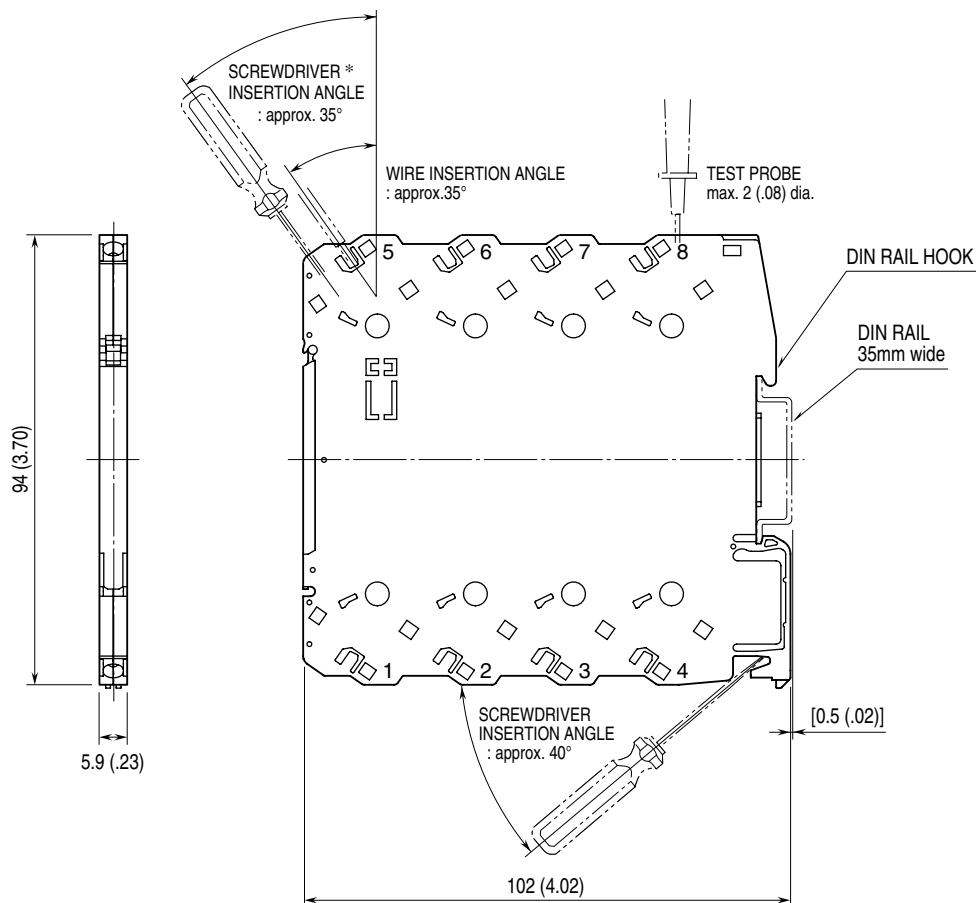

• When mounting, no extra space is needed between units.

*Use a minus screwdriver: tip width 3.8 mm max., tip thickness 0.5 to 0.6 mm

■ CONNECTION DIAGRAM

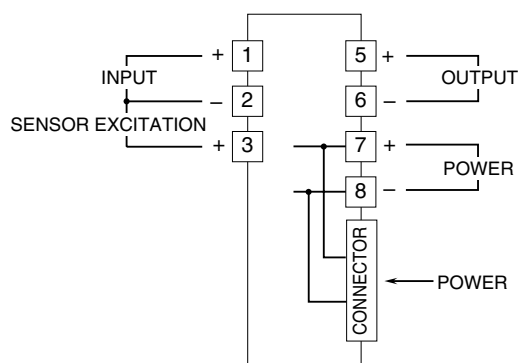

Input Connection Examples

■ Mechanical Contact or Open Collector

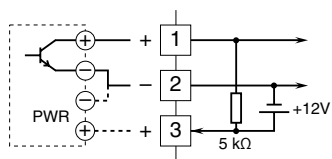

■ Voltage Pulse

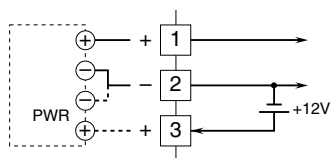

■ 2-Wire Current Pulse

• Built-in Excitation

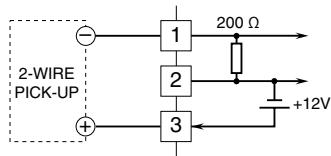

• External DC Supply

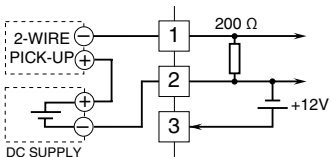

Output Connection Examples

■ Open Collector

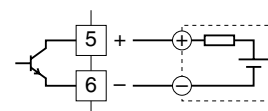

■ Voltage Pulse

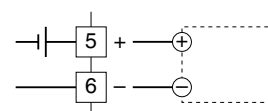

■ WIRING INSTRUCTIONS

- Applicable wire size

Solid: 0.2 to 2.5 mm² (0.55 to 1.75 dia.)

Stranded: 0.2 to 2.5 mm² (Tinning wire ends may cause contact failure and therefore is not recommended.)

Ferruled: 0.2 to 1.5 mm² (0.55 to 1.35 dia.)

- Expose wire conductors by 8 mm (0.31").

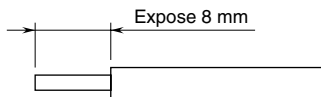

- How to Connect Wires

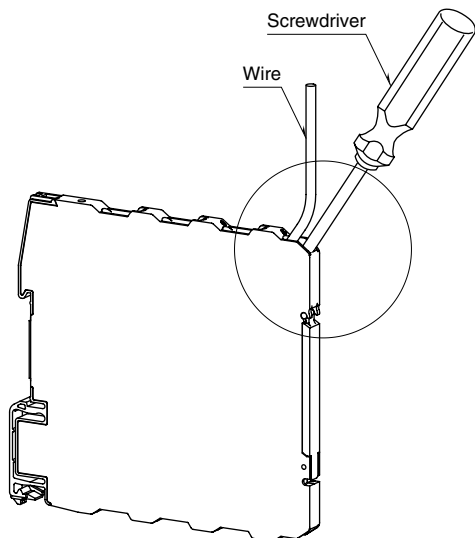

- 1) Insert a minus screwdriver into the wire entry opening, between the clamp and the housing, until its tip hits the bottom where it is firmly held.

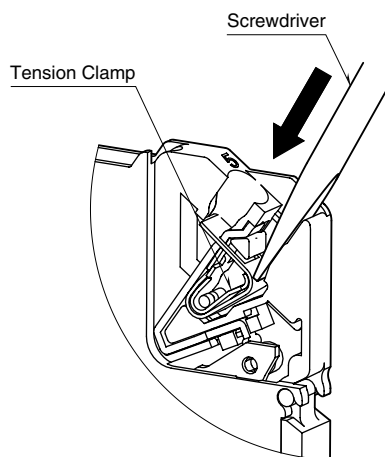

- 2) Insert a wire. Push the screwdriver toward the direction indicated with the arrow in the figure below to widen the opening if necessary.

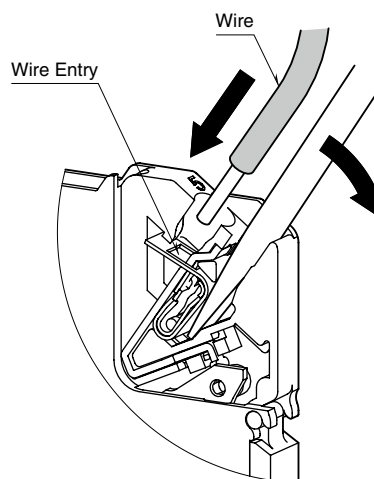

- 3) Confirm that the wire tip hits the bottom and pull out the screwdriver in holding it in position.

Confirm that the wire's insulation tube is not caught in the clamp.

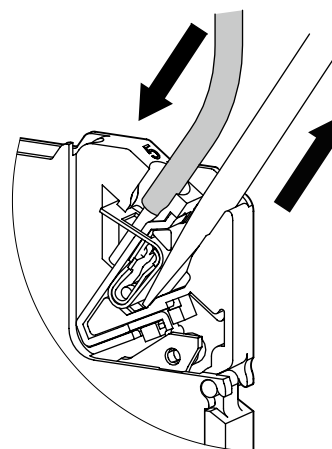

CHECKING

- 1) Terminal wiring: Check that all cables are correctly connected according to the connection diagram.
- 2) Confirm that the wire insulation tubes are not caught in the clamp.
- 3) Power input voltage: Check voltage across the terminal 7 – 8 with a multimeter.
- 4) Input: Check that the input frequency is 30 Hz or less for relay contact, 100 kHz or less for other types of input. Check also that input pulse is 10 msec. or wider for relay contact, 5 μ sec. or wider for other types of input.
- 5) Output: Check that the load resistance meets the described specifications as shown below.

OUTPUT	LOAD REQUIREMENTS
Open collector	50 V DC @ 100 mA max.
Voltage pulse	1.0 k Ω min. for 5 V 2.4 k Ω min. for 12 V 4.8 k Ω min. for 24 V

LIGHTNING SURGE PROTECTION

We offer a series of lightning surge protector for protection against induced lightning surges. Please contact us to choose appropriate models.