

Remote I/O R3 Series

TOTALIZED PULSE INPUT MODULE

(Pi 16 points, connector type)

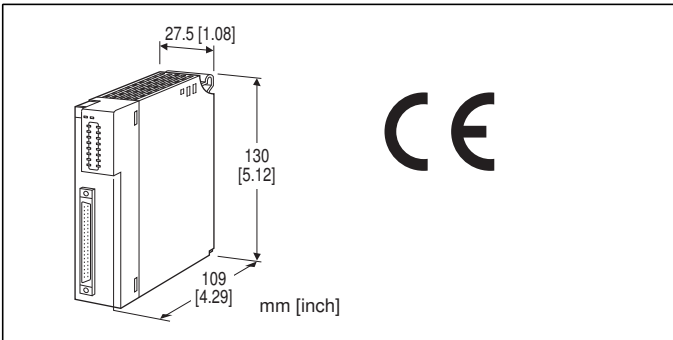

MODEL: R3Y-PA16[1][2]

ORDERING INFORMATION

- Code number: R3Y-PA16[1][2]

Specify a code from below for each of [1] and [2].
(e.g. R3Y-PA16W/A/CE/PRS/Q)

- Specify the specification for option code /Q
(e.g. /C01/SET)

NO. OF CHANNELS

16: 16

[1] COMMUNICATION MODE

S: Single
W: Dual

[2] OPTIONS (multiple selections)

Excitation

Blank: Internal (negative common)
/A: External (24 V DC, negative common)

Standards & Approvals

blank: Without CE
/CE: CE marking

EX-FACTORY SETTING

blank: Enable count reset by host PC/PLC
/PRS: Enable count preset by host PC/PLC

Other Options

blank: none
/Q: Option other than the above (specify the specification)

SPECIFICATIONS OF OPTION: Q (multiple selections)

COATING (For the detail, refer to M-System's web site.)

/C01: Silicone coating
/C02: Polyurethane coating

/C03: Rubber coating

EX-FACTORY SETTING

/SET: Preset according to the Ordering Information Sheet
(No. ESU-8389)

RELATED PRODUCTS

- Connector terminal block (model: CNT)
- Special cable with 40-pin connector (model: FCN)
- Interface module (model: R3-NC1, R3-NC3, R3-NE1, R3-NM1, R3-NDx, R3-NFL1, R3-NP1, R3-NFx, R3-NML3, R3-NF2: Firmware version V0.05 or later)

Note:

- Count reset by host PC/PLC:
Available with this unit and the above mentioned interface modules of firmware version V2.00 or later, except R3-NFx. Notice that Count reset by host PC/PLC via R3-NFx or interface module of previous versions of firmware is unable.
- Count preset by host PC/PLC:

It is only available in combination with this unit displayed 'SW3-4 RESET/PRESET' on the right side panel and the interface module R3-NM1 or R3-NE1 of firmware version V2.00 or later. Count preset is not available for other combination.

Notice that this function is not available in the same time as count preset by host PC/PLC.

GENERAL SPECIFICATIONS

Connection

Internal bus: Via the Installation Base (model: R3-BSx)

Input: 40-pin connector (OTAX N365P040AU (Fujitsu Model FCN-365P040-AU...discontinued))

Internal power: Via the Installation Base (model: R3-BSx)

Isolation: Input to internal bus or internal power

RUN indicator: Bi-color (red/green) LED;
Red when the bus A operates normally;
Green when the bus B operates normally;
Amber when both buses operate normally.

ERR indicator: Bi-color (red/green) LED;
Red with excitation abnormality;
Green in normal operating conditions.

Input status indicator: Red LED; turns on with the input ON.

Count reset: Via DIP switch on the side or one pulse to reset input

Count setting from host PC/PLC: Count reset/count preset is changeable via DIP switch on the side.

INPUT SPECIFICATIONS

Number of input: 16 points

Input resistance: 6 kΩ

Common: Negative commons, all points

Maximum frequency: 100 Hz (ON/OFF time ≥ 5 msec.)

This unit is designed to be able to accept a frequency up to 100 Hz, however, 'chattering' contact must be avoided for accurate measuring of such high frequency. Use relays that do not cause any chattering.

Totalized pulse range: 1 – 10000 ('0' at reset)

Max. pulse range selectable from 1 to 65535 using the R3CON PC Configurator Software. Refer to the R3CON Users Manual for detailed information.

Count at overflow: Reset and restart at '1.'

■ R3Y-PA16x (internal excitation)

Sensing voltage: 13 V DC (max. 24 V with no load)

ON current: ≥ 1.5 mA (≤ 1.5 k Ω)

OFF current: ≤ 0.75 mA (≥ 18 k Ω)

■ R3Y-PA16x/A (external excitation)

Sensing voltage: 24 V DC

ON current: ≥ 1.5 mA (≤ 12 k Ω)

OFF current: ≤ 0.75 mA (≥ 36 k Ω)

INSTALLATION

Operating temperature: -10 to +55°C (14 to 131°F)

Operating humidity: 30 to 90 %RH (non-condensing)

Atmosphere: No corrosive gas or heavy dust

Mounting: Installation Base (model: R3-BSx)

Weight: 200 g (0.44 lb)

PERFORMANCE

Data allocation: 16

Current consumption:

R3Y-PA16x: 100 mA

R3Y-PA16x/A: 80 mA

Insulation resistance: ≥ 100 M Ω with 500 V DC

Dielectric strength: 2000 V AC @ 1 minute

(input to internal bus or internal power)

2000 V AC @ 1 minute (power input to FG; isolated on the power supply module)

STANDARDS & APPROVALS

EU conformity:

EMC Directive

EMI EN 61000-6-4

EMS EN 61000-6-2

RoHS Directive

FUNCTIONS

■ MANUAL COUNT RESET

- 1) Remove Network Module or its cables and interrupt communication with other devices.
- 2) Turn ON the Count Reset SW (SW3-1).
- 3) Return the module to the base and turn the power supply on.

4) ERR LED turns on and the module starts resetting its counter. When the resetting is complete, the LED turns to green. DO NOT remove the power while the red LED is on. The RUN LED starts blinking at the same time.

5) After the green LED is confirmed, turn the power supply off.

6) Turn OFF the Count Reset SW (SW3-1).

7) Return the Network module onto the base and turn the power supply on.

Note: Count Reset SW must be turned OFF after this procedure because the module does not start counting with ON state.

■ REMOTE COUNT RESET INPUT

With the Count Reset Input SW (SW3-3) turned ON, the count reset signal value becomes effective.

SW3-3 = OFF: unused

SW3-3 = ON: reset signal.

One pulse supplied at the Count reset input terminal will be recognized as a reset signal.

■ REMOTE COUNT RESET OPERATION

1) ERR LED turns on (red color) when the reset signal is received.

2) In 1 second, the module starts resetting its counter. When the resetting is complete, the LED turns to green.

3) After 1 second, ERR LED turns back to the state before the reset signal has been received.

Note: Reset signals received while the module is processing (1) through (3) are ignored.

■ COUNT RESET FROM HOST PC/PLC

Refer to "COUNTER SETTING FROM HOST PC/PLC" section hereafter.

EXTERNAL VIEW

FRONT VIEW

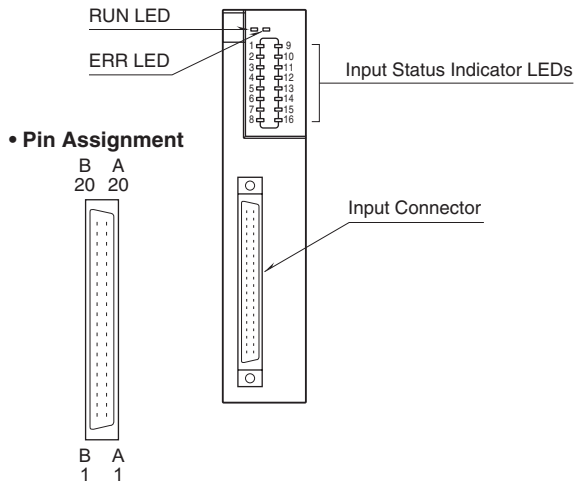

SIDE VIEW

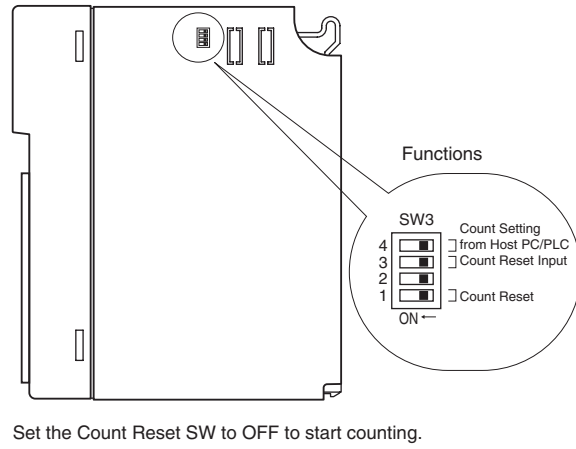

COUNTER SETTING FROM HOST PC/PLC

■ COUNTER RESET

(Available for R3-NC1, R3-NC3, R3-NE1, R3-NM1, R3-NDx, R3-NFL1, R3-NP1, R3-NML3 (Firmware version 2.00 or later))

Setting SW3-4 OFF and turning power on enable the function.

The bits indicating the channels to reset counter are allocated in the first word from host PC/PLC.

When these bits are changed from 0 to 1, the counter is reset. When it is confirmed that the counter is reset, return to 0.

Notice that if the bit remains at 1, the next reset will not work.

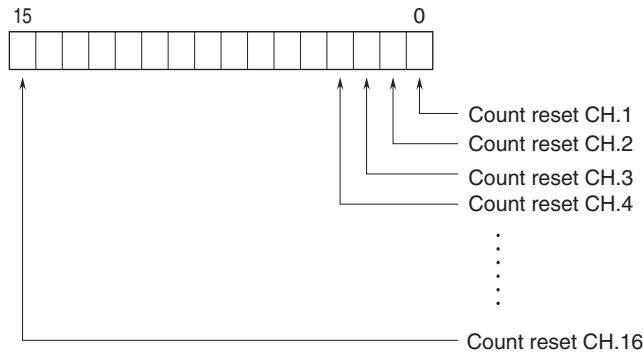

■ COUNTER PRESET

(Available in combination with R3-NE1, R3-NM1 (Firmware version 2.00 or later), and R3Y-PA16 displayed 'SW3-4 RESET/PRESET' on the right side)

Setting SW3-4 ON and turning power on enable the function.

Write the preset value to the Holding Registers, which has same address as the Input Registers.

• Input Registers

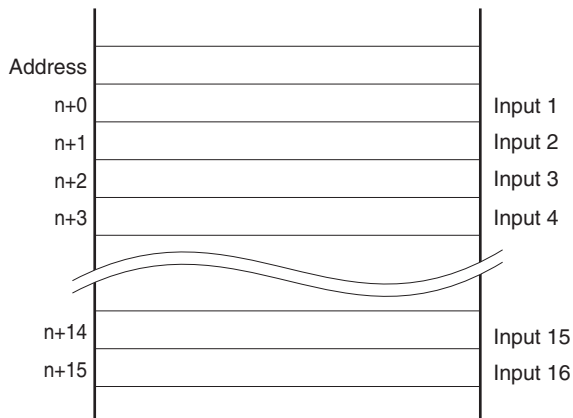

• Holding Registers

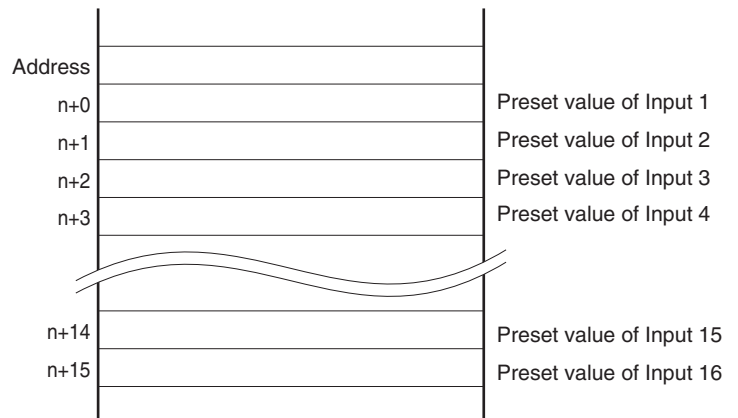

EXTERNAL DIMENSIONS unit: mm [inch]

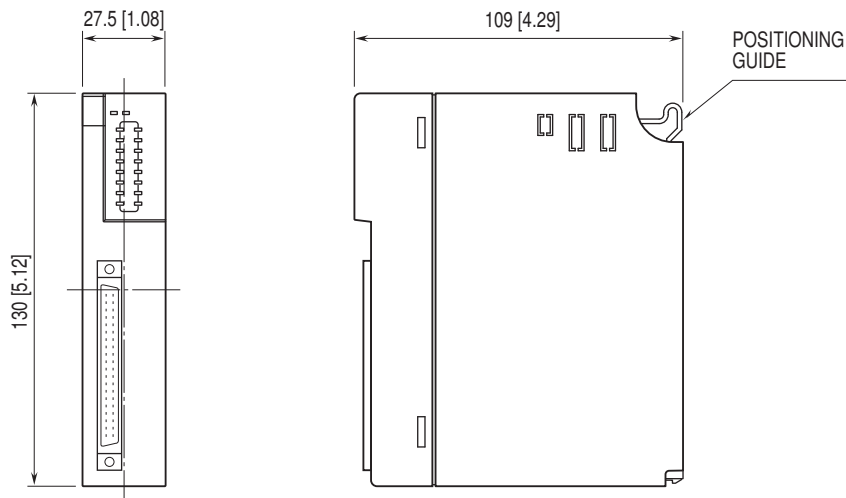

SCHEMATIC CIRCUITRY & CONNECTION DIAGRAM

INTERNAL POWER

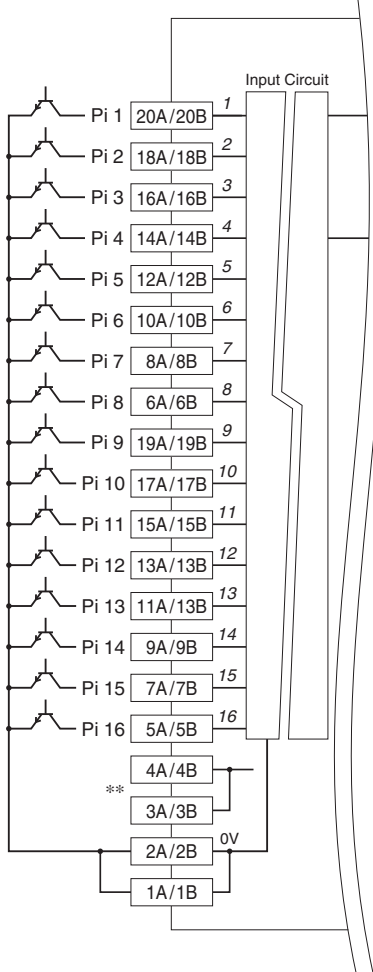

EXTERNAL EXCITATION (OPTION /A)

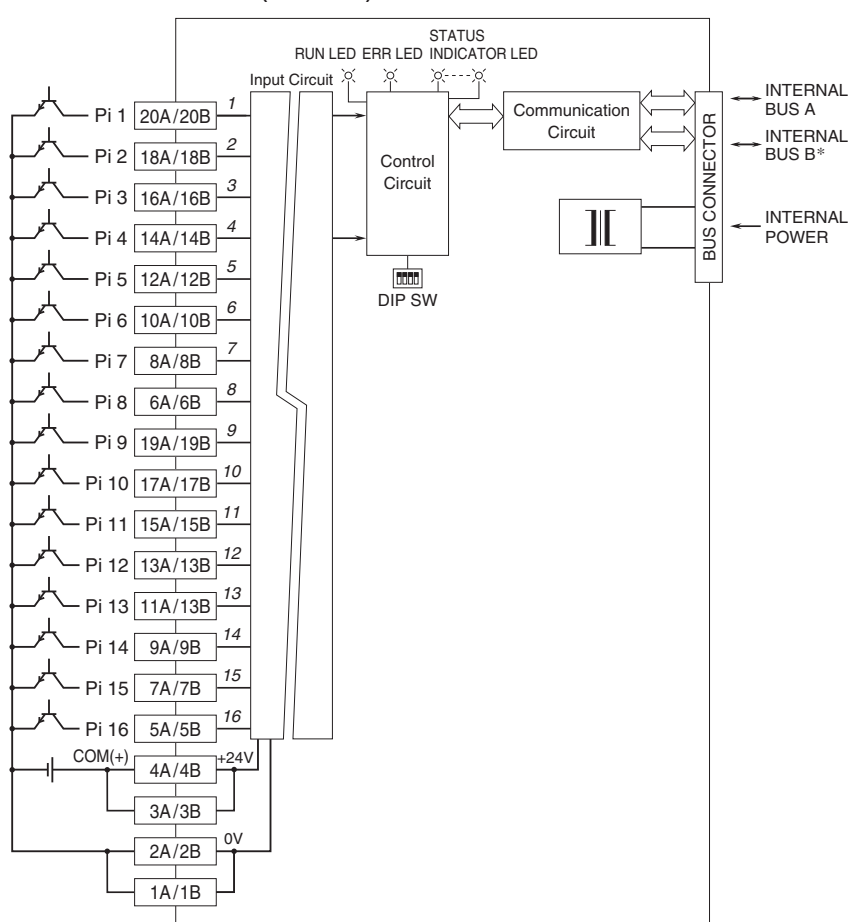

Numbers in italic indicate LED No.s assigned to the front panel LEDs.

* For dual redundant communication.

** DO NOT use the pin No. 4A/4B and 3A/3B.

INPUT CONNECTOR (40-pin)

PIN NO.	ASSIGNMENT	PIN NO.	ASSIGNMENT
1A	0V	1B	0V
2A	0V	2B	0V
3A	+24V	3B	+24V
4A	+24V	4B	+24V
5A	Pi 16	5B	Pi 16
6A	Pi 8	6B	Pi 8
7A	Pi 15	7B	Pi 15
8A	Pi 7	8B	Pi 7
9A	Pi 14	9B	Pi 14
10A	Pi 6	10B	Pi 6
11A	Pi 13	11B	Pi 13
12A	Pi 5	12B	Pi 5
13A	Pi 12	13B	Pi 12
14A	Pi 4	14B	Pi 4
15A	Pi 11	15B	Pi 11
16A	Pi 3	16B	Pi 3
17A	Pi 10	17B	Pi 10
18A	Pi 2	18B	Pi 2
19A	Pi 9	19B	Pi 9
20A	Pi 1	20B	Pi 1



Specifications are subject to change without notice.