

Remote I/O R3 Series

DISCRETE INPUT OUTPUT MODULE

(Di 8 points (internal power), Do 8 points (photo MOSFET relay), connector type)

Typical Applications

- Controls start/stop of field devices with ON/OFF control output
- Simplifies signal hold circuit of field devices
- Utilizing One-Shot Output reduces the load of PLC side.

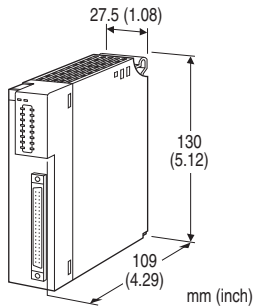

MODEL: R3Y-DAC16D[1][2]

ORDERING INFORMATION

- Code number: R3Y-DAC16D[1][2]
Specify a code from below for each of [1] and [2].
(e.g. R3Y-DAC16DW/Q)
- Specify the specification for option code /Q
(e.g. /C01)

NO. OF CHANNELS

16D: 8 points input (internal power),
8 points output (photo MOSFET relay)

[1] COMMUNICATION MODE

S: Single

W: Dual

[2] OPTIONS

blank: none

/Q: With options (specify the specification)

SPECIFICATIONS OF OPTION: Q

COATING (For the detail, refer to M-System's web site.)

/C01: Silicone coating

/C02: Polyurethane coating

/C03: Rubber coating

CAUTION

- This unit is not designed to be used with the following types of interface modules (models: R3-NC2, R3-NEIP1, R3-NFx, R3-NLx).
- Output completion status data is compatible with interface modules (models: R3-NC1, R3-NC3, R3-NDx, R3-NE1, R3-NFL1, R3-NM1, R3-NM4, R3-NP1) of firmware version V2.00 or higher, and interface modules (models: R3-NM3, R3-NML3) of firmware version V1.00 or higher.

RELATED PRODUCTS

- Connector terminal block (model: CNT)
- Special cable with 40-pin connector (model: FCN)

GENERAL SPECIFICATIONS

Connection

Internal bus: Via the Installation Base (model: R3-BSx)

Input, Output: 40-pin connector

(OTAX Model N365P040AU

(Fujitsu Model FCN-365P040-AU...discontinued)

Internal power: Via the Installation Base (model: R3-BSx)

Isolation: I/O to internal bus or internal power

Output mode setting: One-Shot Output Mode, ON/OFF Control Output Mode, Continuance Output Mode selectable with DIP switch

Data length Setting: 8bit, 4bit selectable with DIP switch
(For ON/OFF Control Output Mode only)

One-shot ON time setting: 0.1 to 25.6 sec. selectable with DIP switch

Max. ON points at once setting: 1, 2, 4, 8 selectable with DIP switch (only in One-Shot Output Mode and ON/OFF Control Output Mode)

ON/OFF control output setting: Swappable its pair with DIP switch.

Output hold setting: Setting for communication error with side DIP SW

RUN indicator: Bi-color (red/green) LED;
Red when the bus A operates normally;
Green when the bus B operates normally;
Amber when both buses operate normally.

ERR indicator: Bi-color (red/ green) LED;
Green in normal operating conditions
Red with the abnormal configuration

Status indicator: Red LED;

1 to 8: Input status, turns on with input ON.

9 to 16: Output status, turns on with output ON.

Di read rate setting: 1 / 5 / 10 / 20 / 50 / 70 / 100 / 200 msec. selectable with DIP SW

INPUT SPECIFICATIONS

Number of input: 8 points
Isolation: Optical isolator
Input resistance: Approx. 6 k Ω
Common: All 8 points (4 terminals)
Sensing: 24 V DC +10 %
ON current/resistance: ≥ 2.5 mA, ≤ 5.5 k Ω
OFF current/resistance: ≤ 1.5 mA, ≥ 8 k Ω
Detection levels
ON: ≥ 15 V
OFF: ≤ 9 V

OUTPUT SPECIFICATIONS

Number of outputs: 8
Rated load voltage: 48 V peak AC/DC
Rated load frequency (AC): 50/60 Hz
 (Operational range: 45 - 66 Hz)
Rated output current: 0.2 A per point
Output ON resistance: ≤ 1 Ω
Leakage current at open circuit: ≤ 0.1 mA
ON delay: ≤ 5 msec.
OFF delay: ≤ 3 msec.
 (When driving an inductive load, external contact protection and noise quenching recommended.)

INSTALLATION

Operating temperature: -10 to +55 $^{\circ}$ C (14 to 131 $^{\circ}$ F)
Operating humidity: 30 to 90 %RH (non-condensing)
Atmosphere: No corrosive gas or heavy dust
Mounting: Installation Base (model: R3-BSx)
Weight: 200 g (0.44 lb)

PERFORMANCE

Output ON time accuracy: Greater between ± 5 % of max. time or ± 0.1 sec. setting
Data allocation: 1
Current consumption: 150 mA
Response time: ≤ 0.1 sec. (delay)
Insulation resistance: ≥ 100 M Ω with 500 V DC
Dielectric strength: 1500 V AC @ 1 minute (I/O to internal bus or internal power)
 2000 V AC @ 1 minute (internal power to FG; isolated on the power supply module)

FUNCTIONS

■ OUTPUT HOLD or OUTPUT OFF

In normal conditions, the module outputs the signal from the preferred bus A.

When an error is detected, the output is switched to the data from the bus B.

• Output Hold

If both are in error, the module holds the signal and stands by until one of the communications recovers.

• Output OFF

If both are in error, the module outputs OFF signals and stands by until one of the communications recovers.

At the startup, it outputs OFF until the communication is established and normal data is received.

■ MAX. ON POINTS AT ONCE

Function available for One-Shot Output Mode and ON/OFF Control Output Mode.

Divide the points to be ON at once. When the total of load current exceeds the maximum load current, "Max. ON Points at Once" function is activated.

The number of the channel turned ON is output in order from the lowest.

Example: Max. ON Points at Once: 1 point; One-shot ON Time setting: 1 sec.

Ch1, 2, 4, 8 all ON: Ch1→Ch2→Ch4→Ch8 are turned ON in this order in a total time of 4 seconds.

Note: When writing in the same channel two or more times, check the previous output completion status to set the output.

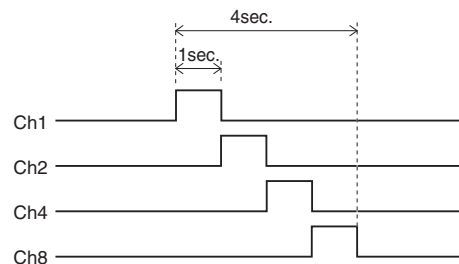

EXTERNAL VIEW

FRONT VIEW

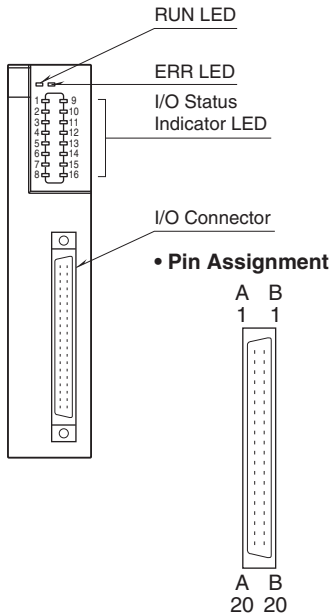

SIDE VIEW

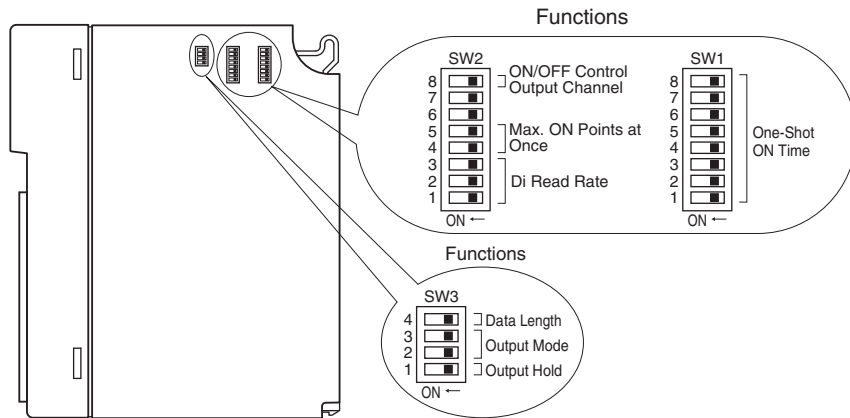

I/O DATA DESCRIPTIONS

ONE-SHOT OUTPUT MODE

8-bit output data (Do 1 through 8) and output (Ch1 through 8) are assigned 1:1.

Do	WRITE	ONE-SHOT OUTPUT/RESET	Di	OUTPUT COMPLETION STATUS
Do 1	1	Ch1 Output	Di 9	Ch1 Output Completion Status
	0	Ch1 Output Completion Reset		
Do 2	1	Ch2 Output	Di 10	Ch2 Output Completion Status
	0	Ch2 Output Completion Reset		
Do 3	1	Ch3 Output	Di 11	Ch3 Output Completion Status
	0	Ch3 Output Completion Reset		
Do 4	1	Ch4 Output	Di 12	Ch4 Output Completion Status
	0	Ch4 Output Completion Reset		
Do 5	1	Ch5 Output	Di 13	Ch5 Output Completion Status
	0	Ch5 Output Completion Reset		
Do 6	1	Ch6 Output	Di 14	Ch6 Output Completion Status
	0	Ch6 Output Completion Reset		
Do 7	1	Ch7 Output	Di 15	Ch7 Output Completion Status
	0	Ch7 Output Completion Reset		
Do 8	1	Ch8 Output	Di 16	Ch8 Output Completion Status
	0	Ch8 Output Completion Reset		

■ ON/OFF CONTROL OUTPUT MODE

• Data Length: 8 bits

Do 1 through 8 are assigned to Ch1 through 8.

Do	WRITE	ONE-SHOT OUTPUT/RESET	Di	OUTPUT COMPLETION STATUS
Do 1 Do 2	0 0	Not Operating		
	1 0	Ch1 Output	Di 9	Ch1 Output Completion Status
	0 1	Ch2 Output	Di 10	Ch2 Output Completion Status
	1 1	Output Data Reset		
Do 3 Do 4	0 0	Not Operating		
	1 0	Ch3 Output	Di 11	Ch3 Output Completion Status
	0 1	Ch4 Output	Di 12	Ch4 Output Completion Status
	1 1	Output Data Reset		
Do 5 Do 6	0 0	Not Operating		
	1 0	Ch5 Output	Di 13	Ch5 Output Completion Status
	0 1	Ch6 Output	Di 14	Ch6 Output Completion Status
	1 1	Output Data Reset		
Do 7 Do 8	0 0	Not Operating		
	1 0	Ch7 Output	Di 15	Ch7 Output Completion Status
	0 1	Ch8 Output	Di 16	Ch8 Output Completion Status
	1 1	Output Data Reset		

The above table shows the case of Not Swapped (SW2-8: OFF). ON/OFF control output is swapped with its pair when SW2-8 is ON. The following is an example of Do 1 and Do 2.

Do	WRITE	ONE-SHOT OUTPUT/RESET	Di	OUTPUT COMPLETION STATUS
Do 1 Do 2	0 0	Not Operating		
	1 0	Ch2 Output	Di 10	Ch2 Output Completion Status
	0 1	Ch1 Output	Di 9	Ch1 Output Completion Status
	1 1	Output Data Reset		

• Data Length: 4 bits

Do 1 through 4 are assigned to Ch1 through 8 as 1:2.

Do	WRITE	ONE-SHOT OUTPUT/RESET	Di	OUTPUT COMPLETION STATUS
Do 1	0	Ch1 Output	Di 9	Ch1 Output Completion Status
	1	Ch2 Output	Di 10	Ch2 Output Completion Status
Do 2	0	Ch3 Output	Di 11	Ch3 Output Completion Status
	1	Ch4 Output	Di 12	Ch4 Output Completion Status
Do 3	0	Ch5 Output	Di 13	Ch5 Output Completion Status
	1	Ch6 Output	Di 14	Ch6 Output Completion Status
Do 4	0	Ch7 Output	Di 15	Ch7 Output Completion Status
	1	Ch8 Output	Di 16	Ch8 Output Completion Status

The above table shows the case of Not Swapped (SW2-8: OFF). ON/OFF control output is swapped with its pair when SW2-8 is ON. The following is an example of Do 1.

Do	WRITE	ONE-SHOT OUTPUT/RESET	Di	OUTPUT COMPLETION STATUS
Do 1	0	Ch2 Output	Di 10	Ch2 Output Completion Status
	1	Ch1 Output	Di 9	Ch1 Output Completion Status

■ CONTINUOUS OUTPUT MODE

Do 1 through 8 are assigned to and Ch1 through 8. When data Do is “1” output is ON and when it is “0” output is OFF. Output completion status Di is related to Do.

Do	CONTINUOUS OUTPUT	Di	OUTPUT COMPLETION STATUS
Do 1	Ch1 Output	Di 9	Ch1 Output Completion Status
Do 2	Ch2 Output	Di 10	Ch2 Output Completion Status
Do 3	Ch3 Output	Di 11	Ch3 Output Completion Status
Do 4	Ch4 Output	Di 12	Ch4 Output Completion Status
Do 5	Ch5 Output	Di 13	Ch5 Output Completion Status
Do 6	Ch6 Output	Di 14	Ch6 Output Completion Status
Do 7	Ch7 Output	Di 15	Ch7 Output Completion Status
Do 8	Ch8 Output	Di 16	Ch8 Output Completion Status

DATA ASSIGNMENT

■ Do

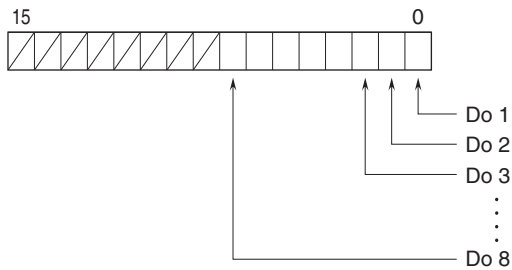

Note 1: For 4-bit length ON/OFF control mode, Do 5 through Do 8 are unavailable.

Note 2: For the combination with Modbus communication module (model: R3-NE1, R3-NM1 and such), use the addresses of Coil (0X) for Modbus I/O assignment.

■ Di

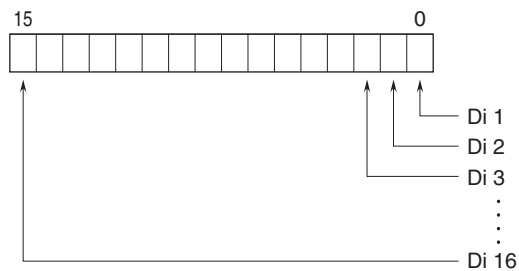

Note 1: Di 9 – 16 data is not practical discrete input data. It is “output completion status” internal data.

Note 2: For the combination with Modbus communication module (model: R3-NE1, R3-NM1 and such), use the addresses of Input (1X) for Modbus I/O assignment.

EXTERNAL DIMENSIONS unit: mm [inch]

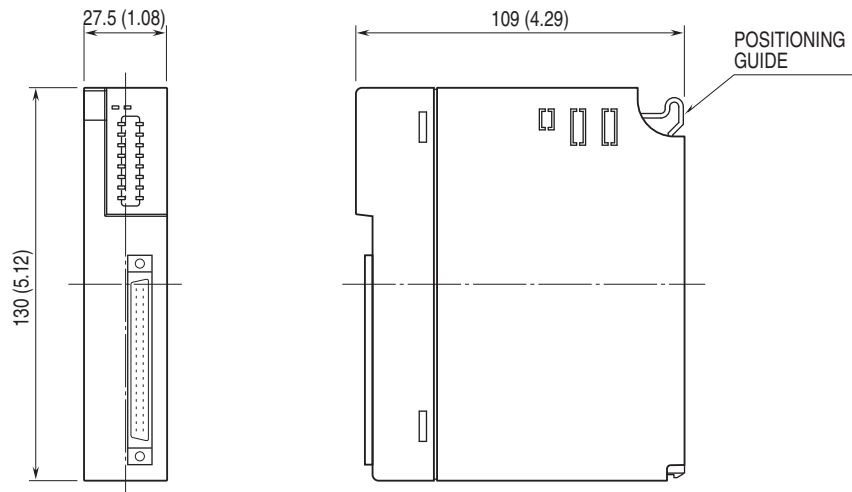

SCHEMATIC CIRCUITRY & CONNECTION DIAGRAM

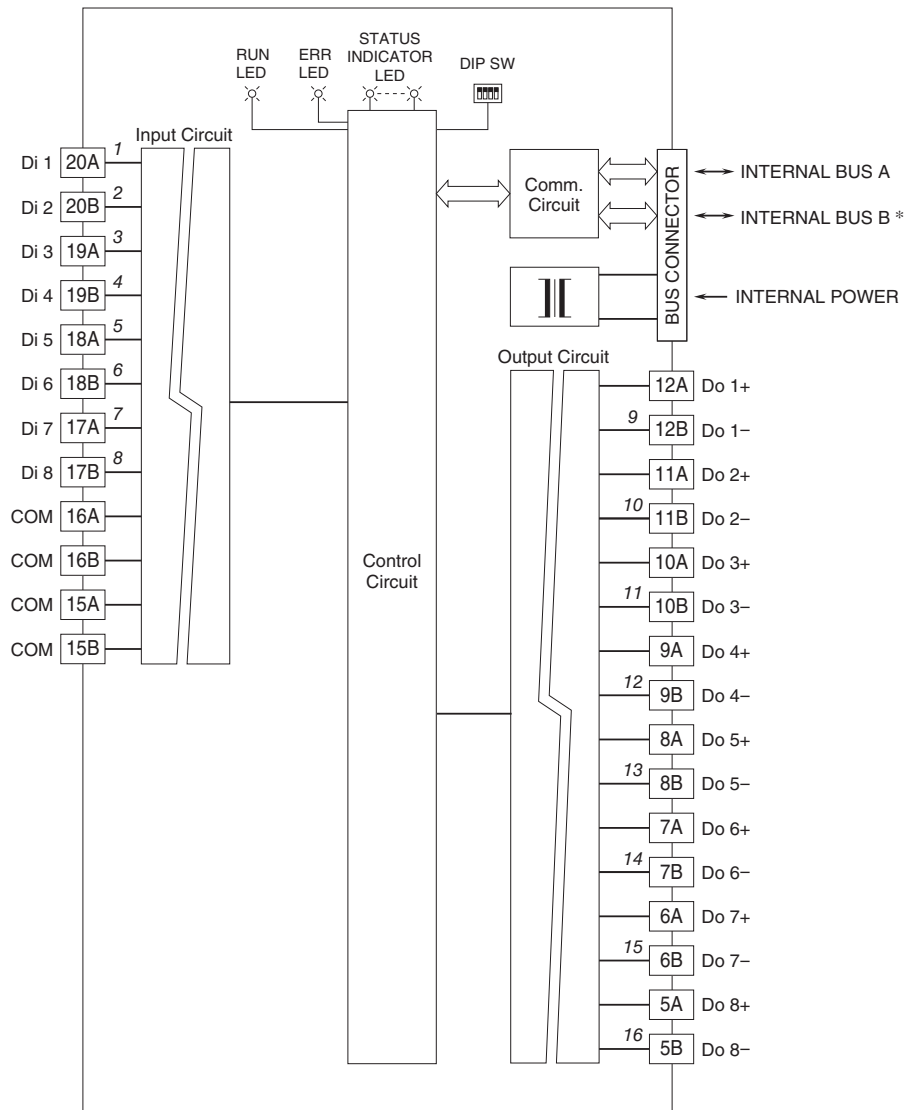

*For dual redundant communication.
Numbers in italic indicate LED No.s assigned to the front panel LEDs.

Input Circuit

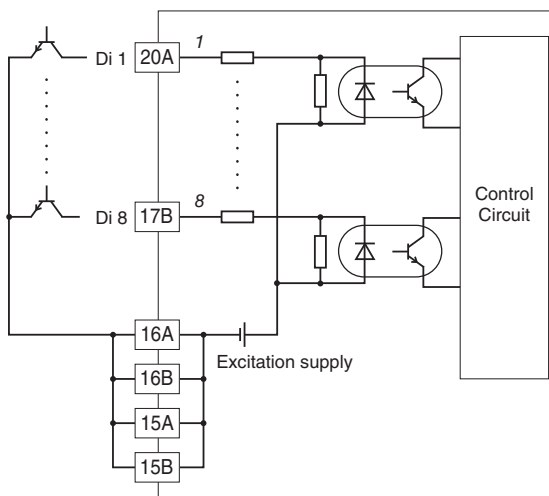

Output Circuit

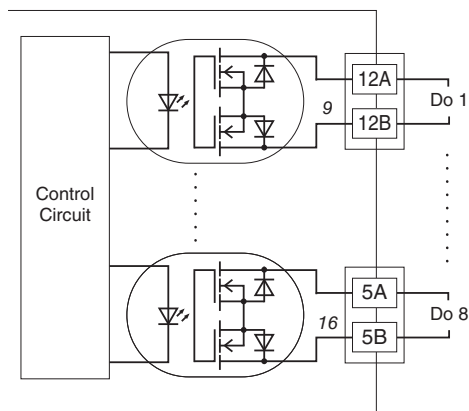

I/O CONNECTOR PIN ASSIGNMENT (40 PIN)

PIN No.	FUNCTION	PIN No.	FUNCTION
1A	NC	1B	NC
2A	NC	2B	NC
3A	NC	3B	NC
4A	NC	4B	NC
5A	Do 8 +	5B	Do 8 –
6A	Do 7 +	6B	Do 7 –
7A	Do 6 +	7B	Do 6 –
8A	Do 5 +	8B	Do 5 –
9A	Do 4 +	9B	Do 4 –
10A	Do 3 +	10B	Do 3 –
11A	Do 2 +	11B	Do 2 –
12A	Do 1 +	12B	Do 1 –
13A	NC	13B	NC
14A	NC	14B	NC
15A	COM	15B	COM
16A	COM	16B	COM
17A	Di 7	17B	Di 8
18A	Di 5	18B	Di 6
19A	Di 3	19B	Di 4
20A	Di 1	20B	Di 2



Specifications are subject to change without notice.