

## Remote I/O R3 Series

### MULTI POWER INPUT MODULE

(clamp-on current sensor type CLSE use)

#### Functions & Features

- Measures simultaneously several variables of a heavy-current power system including computing bidirectional current, phase and harmonics
- 1 or 2 systems
- Uses clamp-on current sensors; No need of current transformers
- Current sensors are easy to install in existing systems

#### Typical Applications

- Energy demand management in manufacturing plants and buildings
- Multi-functional power monitor incorporated in electric devices or in switching boards: saves space, wiring works, and cost

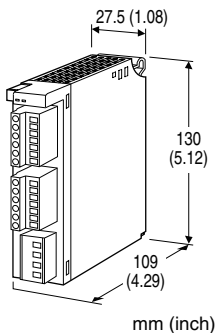

## MODEL: R3-WTU1[1]ES[2]

### ORDERING INFORMATION

- Code number: R3-WTU1[1]ES[2]
- Specify a code from below for each of [1] and [2].  
(e.g. R3-WTU12ES/D/Q)
- Specify the specification for option code /Q  
(e.g. /C01)

### CONFIGURATION

- 1: Single-phase / 2-wire and 3-wire,  
3-phase / 3-wire and 4-wire

### [1] NO. OF SYSTEMS

- 1: 1 system  
2: 2 systems

### INPUT

E: 480 V AC / Sensor type CLSE

### COMMUNICATION MODE

S: Single

### [2] OPTIONS (multiple selections)

#### Data Capacity (address/slot occupied)

blank: 16 words (1)

/D: 32 words (2)

Be sure to use the R3-BSW base with free address setting capability. Refer to 'TRANSMISSION DATA DESCRIPTIONS.'

#### Other Options

blank: none

/Q: Option other than the above (specify the specification)

### SPECIFICATIONS OF OPTION: Q

#### COATING (For the detail, refer to M-System's web site.)

/C01: Silicone coating

/C02: Polyurethane coating

/C03: Rubber coating

### RELATED PRODUCTS

- PC configurator software (model: R3CON)  
Downloadable at M-System's web site.
- Clamp-on current sensor (model: CLSE)  
The clamp-on current sensors, not included in this product package, must be ordered separately. Required number depends upon the system configuration.
- Network module (model: R3-Nx, R30Nx)  
Data resetting from the host device is possible with: V.2.00 or higher versions of the R3-NC1, R3-NC3, R3-NE1 and R3-NM1; V.1.06 or higher versions of the R3-NCIE1; and V.1.06 or higher versions of the R30NECT1, R330NCIE1, and R30NE1. (Confirm the firmware version on R3CON.)  
For other versions and models, use R3CON PC Configurator to reset data.  
For use with the R3-NLx, consult M-System.

### GENERAL SPECIFICATIONS

#### Connection

**Internal bus:** Via the Installation Base (model: R3-BSx)

**Voltage input:** Separable terminal block  
(applicable wire dia.  $\leq 2.5$ ,  $0.5 - 3.5 \text{ mm}^2$ , stripped length 7 mm)

**Current input:** Separable terminal block  
(applicable wire dia.  $\leq 2.4$ ,  $0.5 - 3.5 \text{ mm}^2$ , stripped length 10 mm)

**Internal Power:** Via the Installation Base (model: R3-BSx)

**Configuration:** Single phase/2-wire and 3-wire, 3-phase/3-

wire balanced/unbalanced load, 3-phase/4-wire  
balanced/unbalanced load

**Isolation:** Sensor core to sensor output or current input or  
voltage input to internal bus or internal power

#### Measured variables

**Voltage:** 1 - N, 2 - N, 3 - N, 1 - 2, 2 - 3, 3 - 1

**Current:** 1, 2, 3, N

**Active / reactive / apparent power:** 1, 2, 3,  $\Sigma$

**Power factor:** 1, 2, 3,  $\Sigma$

#### Frequency

**Active energy:** Incoming / outgoing

**Reactive energy:** Incoming / outgoing / lag (inductive)  
/lead (capacitive)

#### Apparent energy

Active / reactive / apparent power intervals (demand)

**Average (demand) current:** 1, 2, 3, N

**Harmonic contents:**  $\Sigma$

Voltage: 1 - N, 2 - N, 3 - N, 1 - 2, 2 - 3, 3 - 1

Current: 1, 2, 3, N

#### Max. and min. values

**Demand history:** 1 to 4

(Programmable within 1 - 60 min.; factory set to 30 min.)

**RUN indicator:** Bi-color (red/green) LED;

Red when the internal bus operates normally.

**ERR indicator:** Bi-color (red/green) LED;

Red with input abnormality (input  $\geq$  120 %, frequency out of  
45 - 65 Hz range);

Green in normal operating conditions.

**Low-end cutout:** Converted as 0 % for the input below a  
preset value; programmable within 0 - 99.9 %; factory set  
to 1 %

**Data resetting:** All energy values; MAX / MIN current values;  
MAX / MIN values other than current; and AVG (demand)  
values

Data resetting from the host device is possible with: V.2.00  
or higher versions of the R3-NC1, R3-NC3, R3-NE1 and  
R3-NM1; V.1.06 or higher versions of the R3-NCIE1; and  
V.1.06 or higher versions of the R3ONECT1, R3ONCIE1, and  
R3ONE1. (Confirm the firmware version on R3CON.)

## INPUT SPECIFICATIONS

**Frequency:** 50 / 60 Hz (45 - 65 Hz)

#### • Voltage Input

##### Rated voltage

Line-to-line (delta voltage): 480 V

Line-neutral (phase voltage): 277 V (single-phase / 2-wire  
and 3-wire)

**Consumption VA:**  $\leq U_{LN}^2 / 300$  k $\Omega$  / phase

**Overload capacity:** 200 % of rating for 10 sec., 120 %  
continuous

**Selectable primary voltage range:** 50 - 400 000 V

#### • Current Input

**CLSE-R5:** 0 - 5 A AC

**CLSE-05:** 0 - 50 A AC

**CLSE-10:** 0 - 100 A AC

**CLSE-20:** 0 - 200 A AC

**CLSE-40:** 0 - 400 A AC

**CLSE-60:** 0 - 600 A AC

**Overload capacity:** 120 % continuous, 500 % for 10 sec.

Note: Use for the circuit not exceed 480 V

**Selectable primary current range:** 1 - 20 000 A (only with  
CLSE-R5, refer to the configurator settings)

#### Operational range

**Current:** 0 - 115 % of the rating

**Voltage, apparent power:**  $\leq$  120 % of the rating

**Active/reactive power:**  $\pm$ 120 % of the rating

**Frequency:** 45 - 65 Hz

**Power factor:**  $\pm$ 1

## INSTALLATION

**Operating temperature:** -10 to +55°C (14 to 131°F)

**Operating humidity:** 30 to 90 %RH (non-condensing)

**Atmosphere:** No corrosive gas or heavy dust

**Mounting:** Installation Base (model: R3-BSx)

Use the R3-BSW with Option /D.

**Weight:** 170 g (0.37 lb)

## PERFORMANCE in percentage of span

**Accuracy** (at 23°C  $\pm$ 10°C or 73.4°F  $\pm$ 18°F, 45 - 65 Hz)

Add the accuracy of the current sensor for overall values.

**Voltage:**  $\pm$ 1.0 % of the rating

**Current:**  $\pm$ 1.0 % of the rating

**Power:**  $\pm$ 1.0 % of the rating

**Power factor:**  $\pm$ 3.0 %

**Frequency:**  $\pm$ 1.0 % of the rating

**Energy:**  $\pm$ 2 %

**Harmonic contents:**  $\pm$ 2.5 % of the rating

**Conversion data:** 16 bits / 32 bits

**Data allocation mode:** 16 or 32

(Refer to 'TRANSMISSION DATA DESCRIPTIONS.')

**Current consumption:** 60 mA

**Input response time:**  $\leq$  2 sec. (0 - 100 %  $\pm$ 1 %)

$\leq$ 3 sec. for frequency and harmonic contents

**Insulation resistance:**  $\geq$  100 M $\Omega$  with 500 V DC

**Dielectric strength:** 2000 V AC @ 1 minute (voltage input or  
current input to internalbus or internal power)

2000 V AC @ 1 minute (sensor core to sensor output)

2000 V AC @ 1 minute (power input to FG; isolated on the  
power supply module)

## TRANSMISSION DATA DESCRIPTIONS

### ■ MEASURANDS

- 16-word Mode (standard)

Measurands and assigned word numbers are specified using the R3CON PC Configurator.

Max. 16 words per module (slot). 1 word = 16 bits, 2 words = 32 bits

• **32-word Mode (option /D)**

Measurands and assigned word numbers are specified using the R3CON PC Configurator.

Max. 32 words by virtually assigning addresses (n) and (n+1) per module. 1 word = 16 bits, 2 words = 32 bits

Be sure to use the R3-BSW base with free address setting capability. DO NOT assign the address (n+1) to any module.

A duplicate address will cause malfunctions.

■ **RESET**

Measurands to be reset can be specified among: all energy values, MAX / MIN current values, MAX / MIN values other than current and AVG (demand) values.

Refer to 'I/O DATA DESCRIPTIONS' in the R3-WTU instruction manual for resetting from the host device.

For detailed information for the selection of measurands and other settings, refer to the R3CON Users Manual.

**EXTERNAL VIEW**

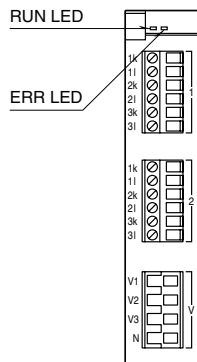

**EXTERNAL DIMENSIONS unit: mm (inch)**

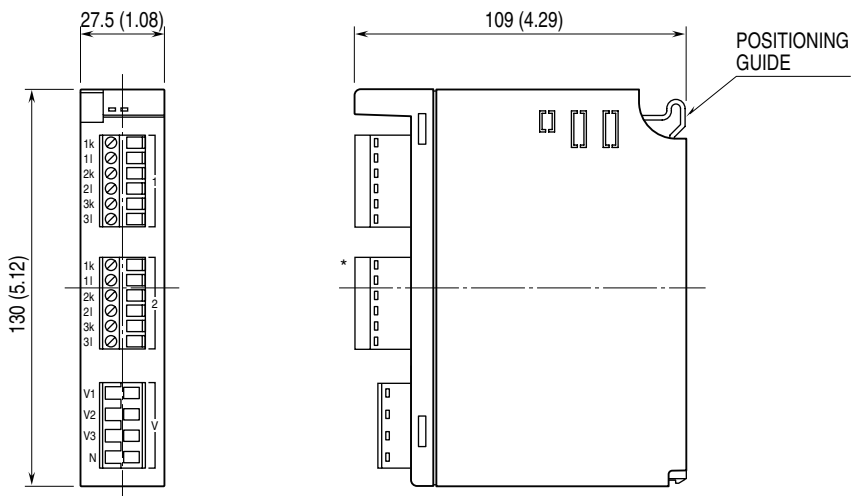

\*Provided only with two circuits option.

## SCHEMATIC CIRCUITRY & CONNECTION DIAGRAM

### ■ SINGLE-PHASE/2-WIRE

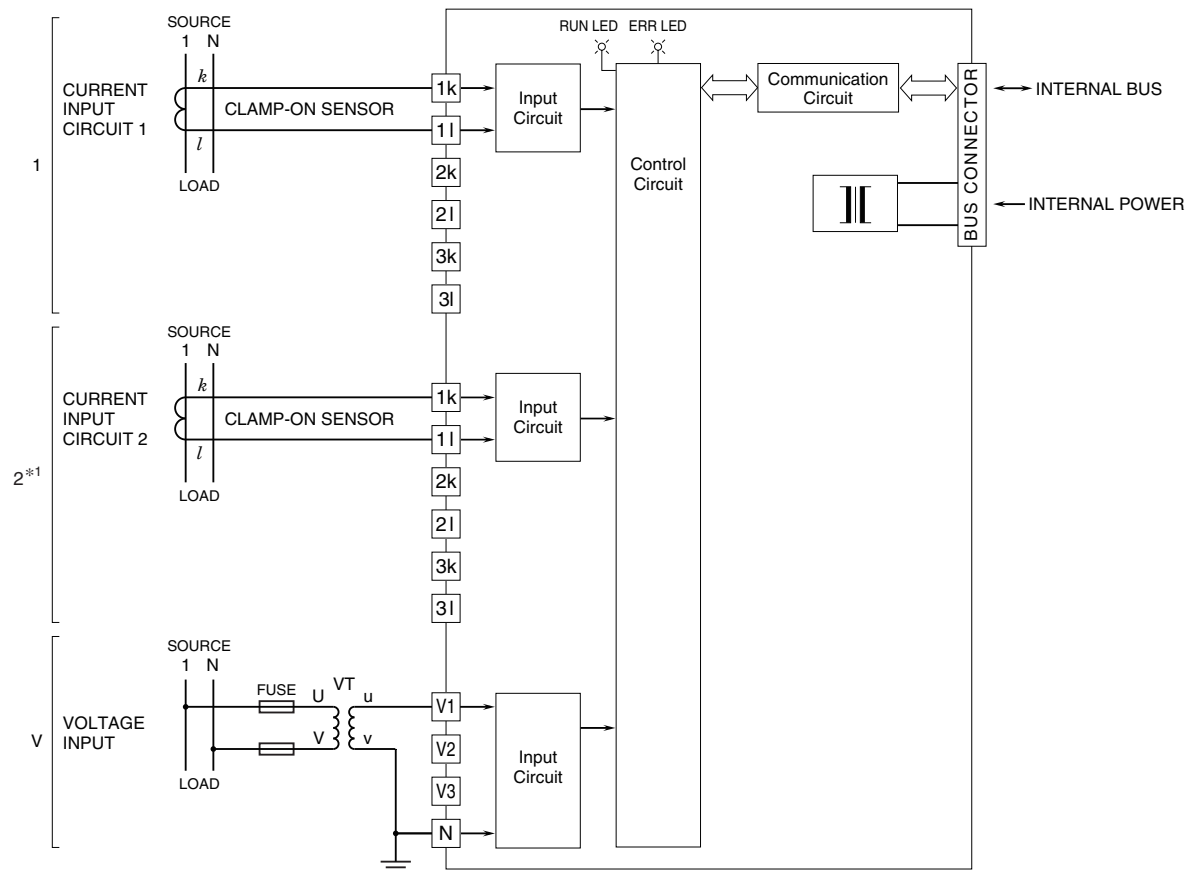

No need of grounding for a low voltage circuit.  
 \*1. Provided only with two circuits option.

## ■ SINGLE-PHASE/3-WIRE

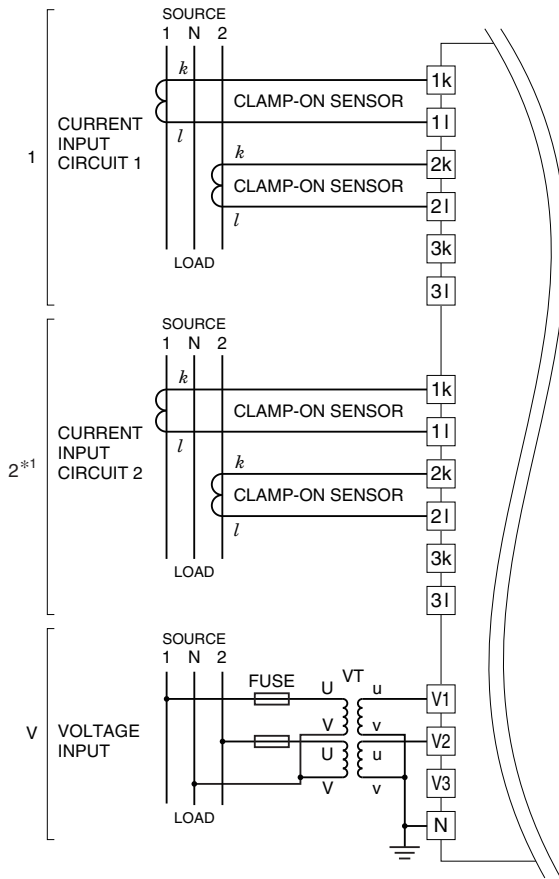

## ■ THREE-PHASE/3-WIRE, BALANCED LOAD

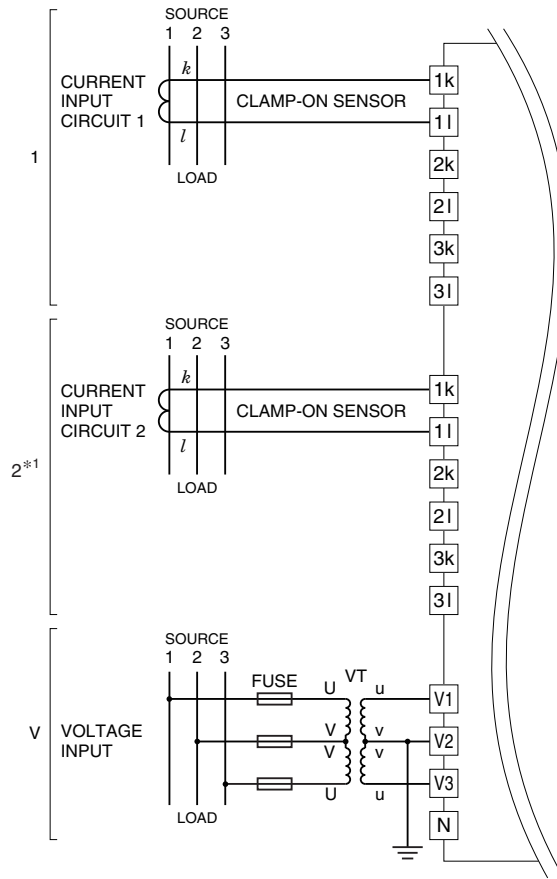

## ■ THREE-PHASE/3-WIRE, UNBALANCED LOAD

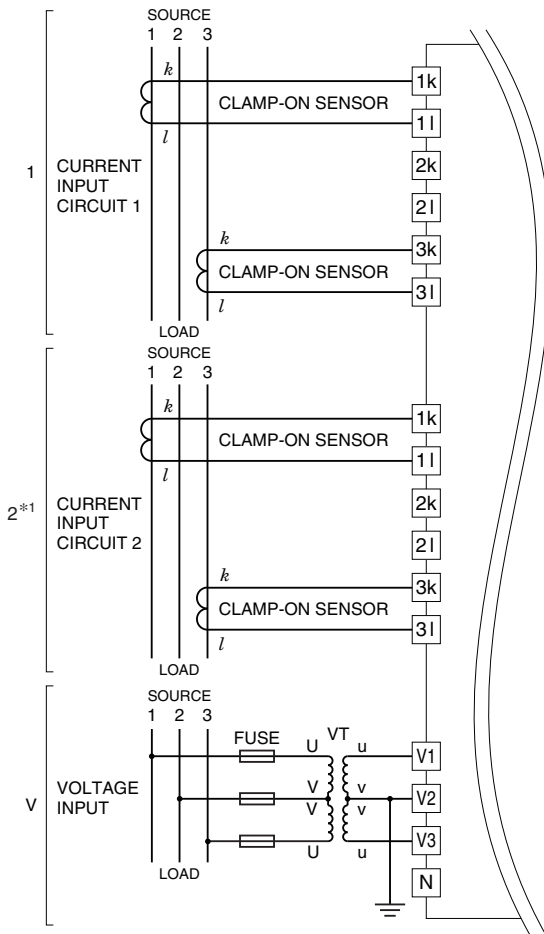

## ■ THREE-PHASE/4-WIRE, BALANCED LOAD

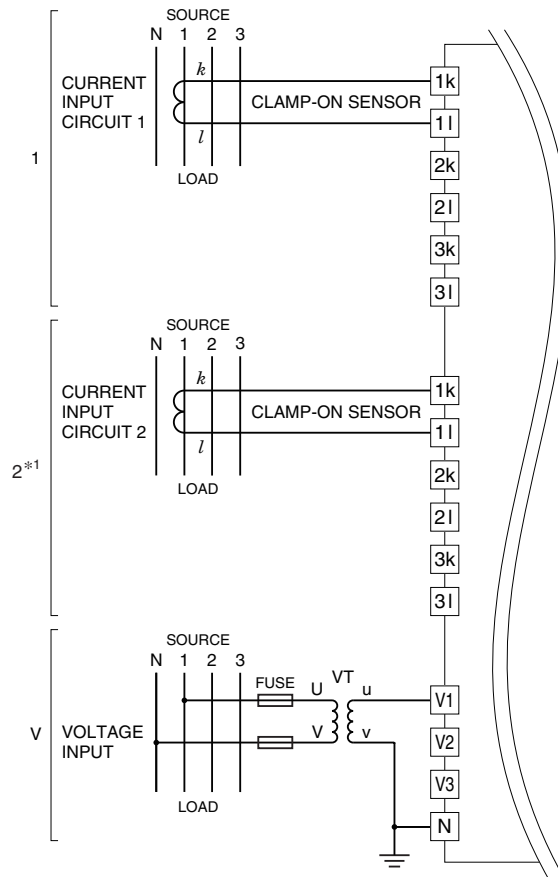

## ■ THREE-PHASE/4-WIRE, UNBALANCED LOAD

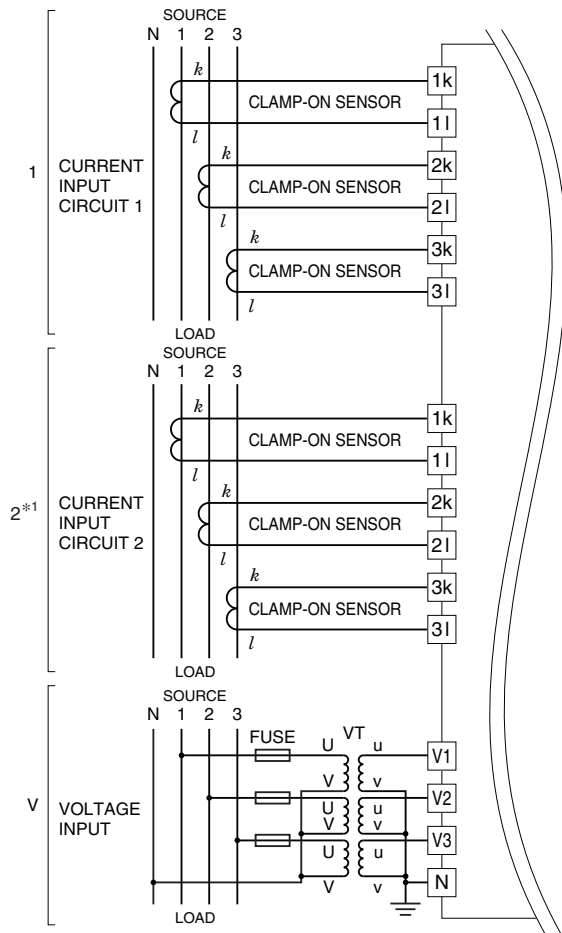

Specifications are subject to change without notice.