

Remote I/O R3 Series

P: 12 V pulse (Load resistance 600 Ω max.)
Open-collector 2 points

TEMPERATURE CONTROL MODULE

Functions & Features

- Two PID controllers
- Universal input x 2 points, control output x 4 points, discrete input x 2 points, clamp-on current sensor input x 2 points
- 2 universal inputs configurable to T/C, RTD, DC current or voltage independently
- Discrete inputs usable to switch PID bank or operation mode
- Control outputs configurable to MV, PV or alarm
- Clamp-on current sensor input enables to detect heater wire break or over current
- Auto tuning function
- Minimum construction with an installation base (model: R3-BS02), interface module and temperature controller module
- Configurable with PC configurator (model: R3CON)
- Mixed installation with other I/O modules

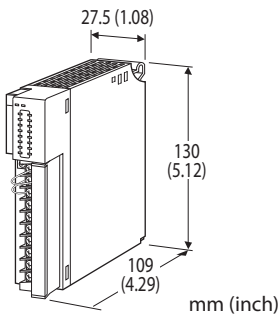

MODEL: R3-TC2[1]S[2]

ORDERING INFORMATION

- Code number: R3-TC2[1]S[2]
- Specify a code from below for each of [1] and [2].
(e.g. R3-TC2AS/Q)
- Specify the specification for option code /Q
(e.g. /C01)

CONTROL LOOP

2: 2 loops

[1] CONTROL OUTPUT

A: 0 - 20 mA DC (Load resistance 500 Ω max.)
Open-collector 2 points
V: 0 - 10 V DC (Load resistance 2 kΩ max.)
Open-collector 2 points

COMMUNICATION MODE

S: Single

[2] OPTIONS

blank: none
/Q: With options (specify the specification)

SPECIFICATIONS OF OPTION: Q

COATING (For the detail, refer to M-System's web site.)

/C01: Silicone coating
/C02: Polyurethane coating
/C03: Rubber coating

RELATED PRODUCTS

- Modbus interface module (model: R3-NM3)
(Not compatible with other Network modules)
- PC configurator software (model: R3CON)
Downloadable at M-System's web site.

A dedicated cable is required to connect the module to the PC. Please refer to the internet software download site or the users manual for the PC configurator for applicable cable types.

- Clamp-on current sensor (model: CLSE)
(Used for detecting the heater wire break)

GENERAL SPECIFICATIONS

Connection

Internal bus: Via the Installation Base (model: R3-BSx)
Input, control output: M3 separable screw terminal (torque 0.5 N·m)

Internal power: Via the Installation Base (model: R3-BSx)

Screw terminal: Nickel-plated steel

Isolation: Pv1 to Pv2 to CT1 or CT2 to Di1 or Di2 to MV1 or MV2 to Do1 or Do2 to internal bus or internal power

CT Input waveform

RMS sensing: Up to 15 % of 3rd harmonic content

RUN indicator: Bi-color (red/green) LED;

Red when the internal bus operates normally.

ERR indicator: Bi-color (red/green) LED; Red at device error; Green in normal operating conditions.

Loop status indicator (RUN1): Red LED; turns on when loop 1 operating

Loop status indicator (AUTO1): Red LED; turns on during auto mode, turns off during manual mode at loop 1

Loop status indicator (ERR1): Red LED; turns on during error at loop 1

Loop status indicator (ALM1): Red LED; turns on when alarm

trip on loop 1

Loop status indicator (RUN2): Red LED; turns on when loop 2 operating

Loop status indicator (AUTO2): Red LED; turns on during auto mode, turns off during manual mode at loop 2

Loop status indicator (ERR2): Red LED; turns on during error at loop 2

Loop status indicator (ALM2): Red LED; turns on when alarm trip on loop 2

Control mode: Standard PID, heating and cooling control (ON/OFF, PID)

Proportional band (P): 0.1 to 999.9 (temperature unit)

Integral time (I): 0.0 to 9999.9 sec.

Derivative time (D): 0.0 to 9999.9 sec.

Auto-tuning: Limit cycle method

Alarm: Deviation high & low, absolute high & low, etc.

Sampling cycle: 100 msec.

Control cycle: 0.1 to 99.9 sec.

MV output range: -5 - +105 %

Parameters: Stored in E²PROM; write/erase cycle endurance: less than 100 000

Parameter setting: With PC configurator software (model: R3CON)

User-configurable items: With PC configurator software (model: R3CON)

- Input type
- Input range
- Output range
- Cold junction compensation; CJC sensor attached to input terminal. CJC can be enabled or disabled per each universal input.

INPUT SPECIFICATIONS

■ Universal input 1, 2 (Pv1, Pv2)

For type and range configuration, refer to the instruction manual.

DC Current:

Input range: 0 - 20 mA DC

Input resistance: 49.9 Ω resistor incorporated

• DC voltage input

Input resistance: ≥ 10 kΩ (-1000 to +1000 mV DC)

Input resistance: ≥ 1 MΩ (-10 to + 10 V DC)

• Thermocouple

Input resistance: ≥ 10 kΩ

Input range: Refer to the table 1

Burnout sensing: ≤ 4 μA

Conformance range: Refer to the table 1

• RTD (2-wire or 3-wire)

Excitation: ≤ 0.33 mA

Allowable leadwire resistance: 20 Ω per wire

• Resistance

Excitation: ≤ 0.33 mA

Allowable leadwire resistance: 20 Ω per wire

• Potentiometer

Excitation: ≤ 0.33 mA

Allowable leadwire resistance: 20 Ω per wire

■ Clamp-on current sensor (CT1, CT2)

(Sensor model No.: AC input)

CLSE-R5: 0 - 5 A

CLSE-05: 0 - 50 A

CLSE-10: 0 - 100 A

CLSE-20: 0 - 200 A

CLSE-40: 0 - 400 A

CLSE-60: 0 - 600 A

Frequency: 50 / 60 Hz (45 - 65 Hz)

Operational range: 0 - 120 % of rating

Overload capacity:

CLSE-R5: 10 A continuous

CLSE-05: 60 A continuous

CLSE-10: 120 A continuous

CLSE-20: 240 A continuous

CLSE-40: 480 A continuous

CLSE-60: 720 A continuous

Be sure that the input voltage is of 480 V or less.

■ Discrete Input (Di1, Di2)

Contact rating: 3.3 V @1 mA

Detection levels:

≤ 15 kΩ / 0.5 V at close

≥ 350 kΩ / 2.5 V at open

OUTPUT SPECIFICATIONS

Four control outputs are configurable to Mv, Ao or Do.

■ Control Output (Mv1, Mv2)

Specify the type of output with the code number.

• DC Current: 0 - 20 mA DC

Operational range: 0 - 23 mA DC

Load resistance: ≤ 500 Ω

• DC Voltage: 0 - 10 V DC

Operational range: 0 - 11.5 V DC

Load resistance: ≥ 2 kΩ

■ Voltage Pulse

Maximum frequency: 1 Hz

Minimum pulse width: 1 msec.

Hi level: 12 V ±15 %

Lo level: ≤ 0.5 V

Load resistance: 600 Ω min.

■ Control Output (Do1, Do2)

• Open collector

Maximum frequency: 1 Hz

Minimum pulse width: 1 msec.

Output rating: 50 V DC 100 mA (resistive load)

Saturation voltage: 0.5 V DC

INSTALLATION

Operating temperature: -10 to +55°C (14 to 131°F)

Operating humidity: 30 to 90 %RH (non-condensing)

Atmosphere: No corrosive gas or heavy dust

Mounting: Installation Base (model: R3-BSx)

Weight: 200 g (0.44 lb)

PERFORMANCE

Accuracy

• **Pv1 or Pv2:** Refer to "Input type, range & conversion accuracy" section.

• **CT1 or CT2:** $\pm 2\%$ (sensor error margin not included)

• **MV1 or MV2:** $\pm 0.5\%$ (added to the input accuracy)

Data allocation: 8

Current consumption: ≤ 120 mA

Cold junction compensation error:

$\pm 2.0^\circ\text{C}$ at 0 - 50°C ($\pm 3.6^\circ\text{F}$ at 32 - 122°F)

Temp. coefficient

• **Pv1 or Pv2:** $\pm 0.03\%/^\circ\text{C}$ ($\pm 0.02\%/^\circ\text{F}$)

• **CT1 or CT2:** $\pm 0.03\%/^\circ\text{C}$ ($\pm 0.02\%/^\circ\text{F}$)

Response time

• **CT1 or CT2:** ≤ 2 sec. (0 - 90 %)

• **Mv1 or Mv2:** ≤ 1 sec. (0 - 90 %, DC output)

Burnout response: ≤ 10 sec.

Insulation resistance: ≥ 100 M Ω with 500 V DC

Dielectric strength: 1000 V AC @1 minute (Pv1 to Pv2 to CT1 or CT2 to Di1 or Di2 to MV1 or MV2 to Do1 or Do2 to internal bus or internal power)

1500 V AC @1 minute (internal power to FG)

INPUT TYPE, RANGE & CONVERSION ACCURACY

[Table 1]

INPUT TYPE	INPUT RANGE		ACCURACY			
DC Current	0 – 20mA DC		±20μA			
DC Voltage	-1000 – +1000mV DC		When maximum range*2 is 50 mV or less: ±20μV When maximum range*2 is 120 mV or less: ±40μV When maximum range*2 exceeds 120 mV: ±200μV			
	-10 – +10V DC		± 20mV			
Potentiometer	0 – 150Ω, 0 – 300Ω, 0 – 600Ω, 0 – 1200Ω, 0 – 2500Ω, 0 – 4000Ω		Larger value of either ±0.1 Ω or ±0.1 %			
Resistor	0 – 4000Ω		Larger value of either ±0.1 Ω or ±0.1 %			
Thermocouple	°C			°F		
	INPUT RANGE	ACCURACY *1	CONFORMANCE RANGE	INPUT RANGE	ACCURACY *1	CONFORMANCE RANGE
(PR)	0 – 1760	±1.80	0 – 1760	32 – 3200	±3.24	32 – 3200
K (CA)	-270 – +1370	±0.40	-150 – +1370	-454 – +2498	±0.72	-238 – +2498
E (CRC)	-270 – +1000	±0.60	-170 – +1000	-454 – +1832	±1.08	-274 – +1832
J (IC)	-210 – +1200	±0.70	-180 – +1200	-346 – +2192	±1.26	-292 – +2192
T (CC)	-270 – +400	±0.50	-170 – +400	-454 – +752	±0.90	-274 – +752
B (RH)	100 – 1820	±2.00	400 – 1760	212 – 3308	±3.60	752 – 3200
R	-50 – +1760	±1.00	200 – 1760	-58 – +3200	±1.80	392 – 3200
S	-50 – +1760	±1.00	0 – 1760	-58 – +3200	±1.80	32 – 3200
C (WRe 5-26)	0 – 2315	±1.00	0 – 2315	32 – 4199	±1.80	32 – 4199
N	-270 – +1300	±0.50	-130 – +1300	-454 – +2372	±0.90	-202 – +2372
U	-200 – +600	±0.50	-200 – +600	-328 – +1112	±0.90	-328 – +1112
L	-200 – +900	±0.30	-200 – +900	-328 – +1652	±0.54	-328 – +1652
P (Platinel II)	0 – 1395	±0.30	0 – 1395	32 – 2543	±0.54	32 – 2543
RTD	°C			°F		
	INPUT RANGE	ACCURACY	INPUT RANGE	ACCURACY	ACCURACY	ACCURACY
Pt 100 (JIS '97, IEC)	-200 – +850	±0.40	-328 – +1562	±0.72	±0.72	±0.72
Pt 500	-200 – +850	±0.40	-328 – +1562	±0.72	±0.72	±0.72
Pt 1000	-200 – +850	±0.40	-328 – +1562	±0.72	±0.72	±0.72
Pt 50Ω (JIS '81)	-200 – +649	±0.60	-328 – +1200	±1.08	±1.08	±1.08
JPt 100 (JIS '89)	-200 – +510	±0.40	-328 – +950	±0.72	±0.72	±0.72
Ni 508.4 Ω	-50 – +200	±0.60	-58 – +392	±1.08	±1.08	±1.08
Cu 10 @25°C	-50 – +250	±2.00	-58 – +482	±3.60	±3.60	±3.60

*1. Thermocouple: CJC error margin (2.0 °C, 3.6 °F) added value indicated above.

*2. Maximum range: Absolute value of 0% or 100% of the input range, whichever is greater.

EXTERNAL VIEW

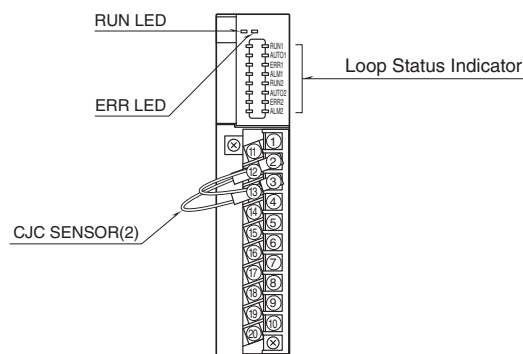

EXTERNAL DIMENSIONS & TERMINAL ASSIGNMENTS unit: mm [inch]

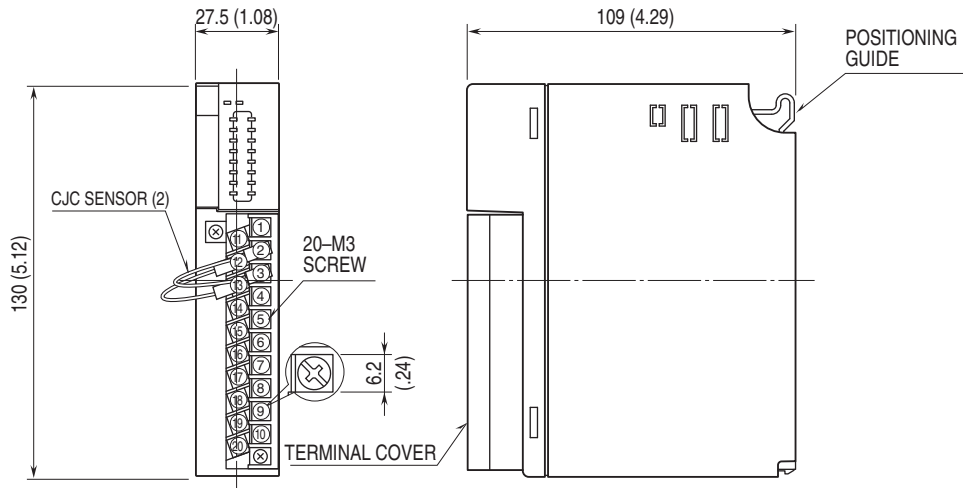

SCHEMATIC CIRCUITRY & CONNECTION DIAGRAM

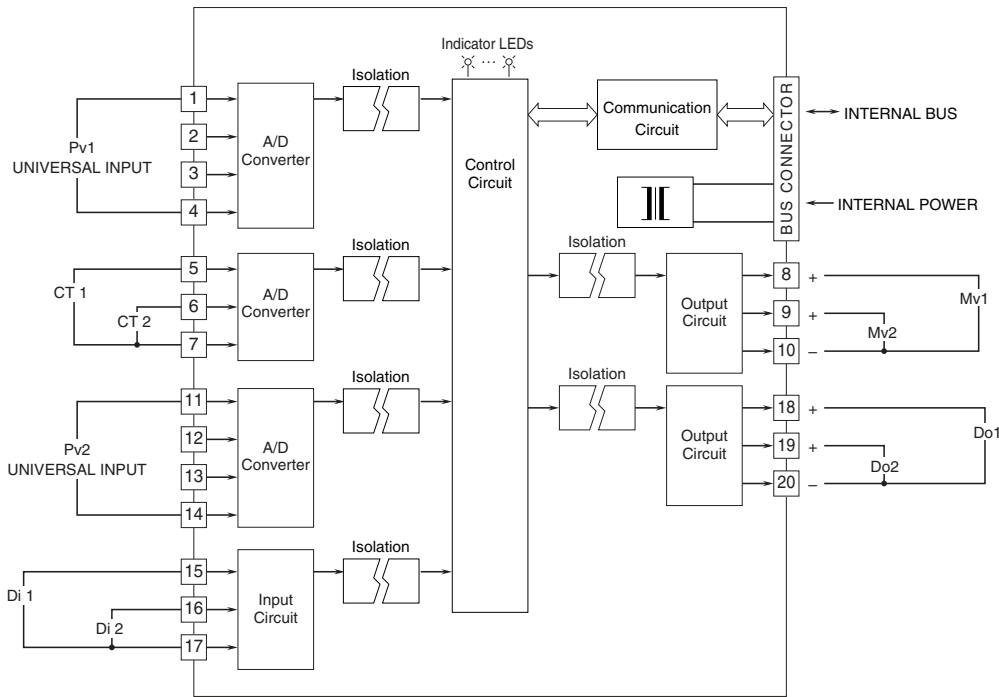

■ UNIVERSAL INPUT CONNECTION (Pv1) e.g.

- DC Voltage (-10 ~ +10V DC)
- DC Current (0 ~ 20mA DC)

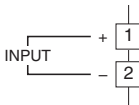

- DC Voltage (-1000 ~ +1000mV DC)

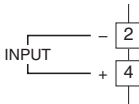

•Thermocouple

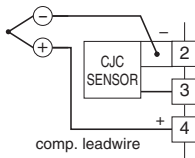

•RTD/Resistor (3-wire)

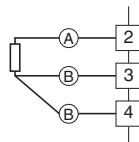

•RTD/Resistor (2-wire)

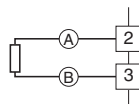

•Potentiometer

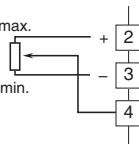

■ UNIVERSAL INPUT CONNECTION (Pv2) e.g.

- DC Voltage (-10 ~ +10V DC)
- DC Current (0 ~ 20mA DC)

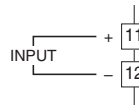

- DC Voltage (-1000 ~ +1000mV DC)

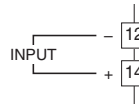

•Thermocouple

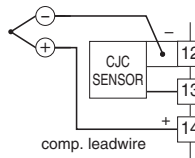

•RTD/Resistor (3-wire)

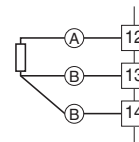

•RTD/Resistor (2-wire)

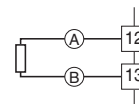

•Potentiometer

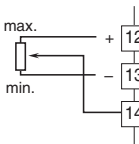

■ CT 1 / CT 2 CONNECTION e.g.

- Clamp-on current Sensor

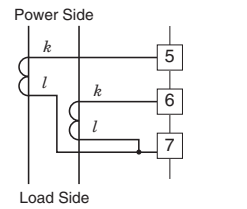

■ DISCRETE INPUT CONNECTION e.g.

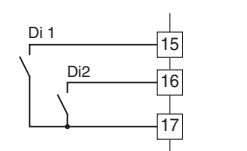

■ CONTROL OUTPUT 1 & 2 CONNECTION e.g.

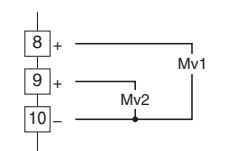

■ CONTROL OUTPUT 3 & 4 CONNECTION e.g.

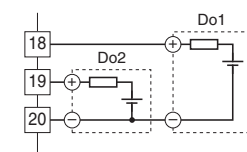

SYSTEM CONFIGURATION EXAMPLES

■ 1 loop heating ON/OFF control and heater wire break detection

1. Installation example:

- Base (model: R3-BS)
- Interface Module (model: R3-NM3)
- Temperature Control Module (model: R3-TC2)
- Clamp-on Current Sensor (model: CLSE)
- Oven
- Heater
- Relay
- Temperature sensor

2. Process until start operating:

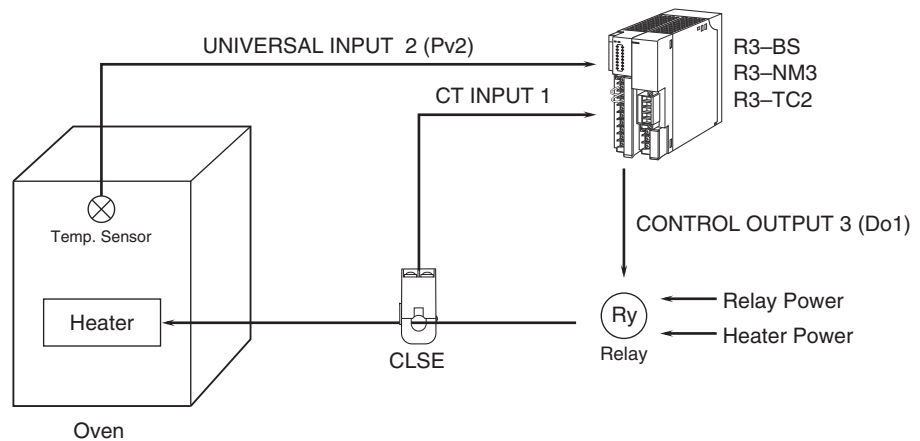
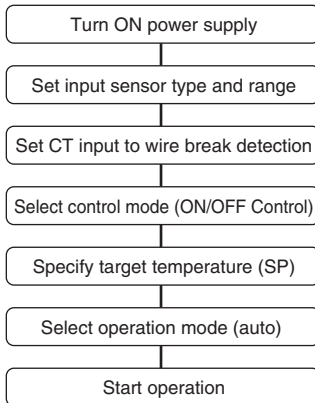

■ 1 loop heating and cooling control (PID)

1. Installation example:

- Base (model: R3-BS)
- Power Supply Module (R3-PS1)
- Interface Module (model: R3-NM3)
- Temperature Control Module (model: R3-TC2)
- DC Voltage Input Module (model: R3-SV4)
(Other R3 modules also available)
- Object to heat/cool
- Temperature sensor

2. Process until start operating:

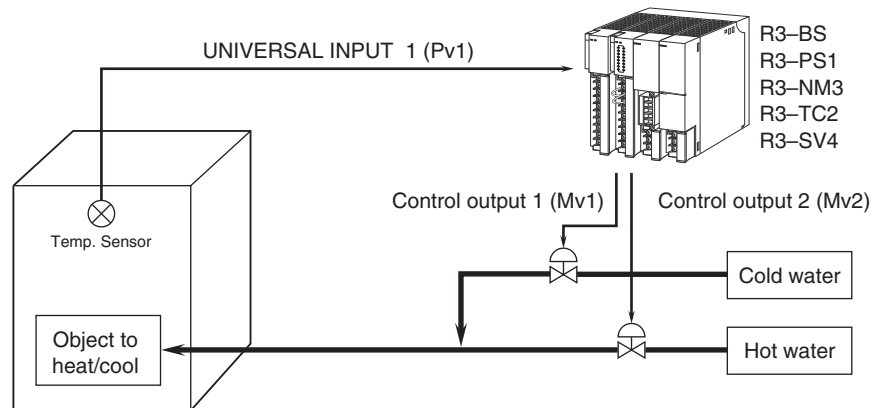
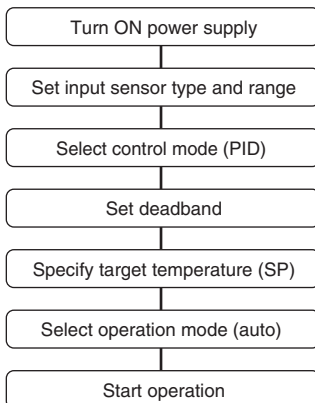

Note: The examples above are for single loop, however, dual loop control is also available using only one R3-TC2.



Specifications are subject to change without notice.