

## Remote I/O R3 Series

/C03: Rubber coating

### DISCRETE INPUT OUTPUT MODULE

(Di & Do 8 points each; internal power, tension clamp terminal block)

#### Typical Applications

- Controls start/stop of field devices with ON/OFF control output
- Simplifies signal hold circuit of field devices
- Utilizing One-Shot Output reduces the load of PLC side.

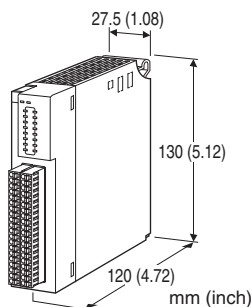

## MODEL: R3S-DAC16A[1][2]

### ORDERING INFORMATION

- Code number: R3S-DAC16A[1][2]  
Specify a code from below for each [1] and [2].  
(e.g. R3S-DAC16AW/Q)
- Specify the specification for option code /Q  
(e.g. /C01)

### NO. OF CHANNELS

16: 8 points input, 8 points output

### EXCITATION SUPPLY

A: Internal

### [1] COMMUNICATION MODE

S: Single

W: Dual

### [2] OPTIONS

blank: none

/Q: With options (specify the specification)

### SPECIFICATIONS OF OPTION: Q

**COATING (For the detail, refer to M-System's web site.)**

/C01: Silicone coating

/C02: Polyurethane coating

### CAUTION

- This unit is not designed to be used with the following types of interface modules (models: R3-NC2, R3-NEIP1, R3-NFx, R3-NLx).
- Output completion status data is compatible with interface modules (models: R3-NC1, R3-NC3, R3-NDx, R3-NE1, R3-NFL1, R3-NM1, R3-NM4, R3-NP1) of firmware version V2.00 or higher, and interface modules (models: R3-NM3, R3-NML3) of firmware version V1.00 or higher.

### GENERAL SPECIFICATIONS

#### Connection

**Internal bus:** Via the Installation Base (model: R3-BSx)

**I/O:** Separable tension clamp terminal  
(applicable wire size: 0.2 to 1.5 mm<sup>2</sup>, stripped length 10 mm)

**Internal Power:** Via the Installation Base (model: R3-BSx)

**Isolation:** I/O to internal bus or internal power

**Output mode setting:** One-Shot Output Mode, ON/OFF Control Output Mode, Continuance Output Mode selectable with DIP switch

**Data length Setting:** 8bit, 4bit selectable with DIP switch  
(For ON/OFF Control Output Mode only)

**One-shot ON time setting:** 0.1 to 25.6 sec. selectable with DIP switch

**Max. ON points at once setting:** 1, 2, 4, 8 selectable with DIP switch (only in One-Shot Output Mode and ON/OFF Control Output Mode)

**ON/OFF control output setting:** Swappable its pair with DIP switch.

**Output hold setting:** Setting for communication error with side DIP SW

**RUN indicator:** Bi-color (red/green) LED;  
Red when the bus A operates normally;  
Green when the bus B operates normally;  
Amber when both buses operate normally.

**ERR indicator:** Bi-color (red/ green) LED;  
Green in normal operating conditions  
Red with the abnormal configuration

**Status indicator:** Red LED;

**1 to 8:** Input status, turns on with input ON.

**9 to 16:** Output status, turns on with output ON.

**Di read rate setting:** 1 / 5 / 10 / 20 / 50 / 70 / 100 / 200 msec. selectable with DIP SW

### INPUT SPECIFICATIONS

**Number of input:** 8 points

**Isolation:** Optical isolator

**Input resistance:** Approx. 6 kΩ

**Common:** All 8 points (24 terminals, common with the output)

**Sensing:** 24 V DC +10 %

**ON current/resistance:**  $\geq 2.5$  mA,  $\leq 5.5$  k $\Omega$

**OFF current/resistance:**  $\leq 1.5$  mA,  $\geq 7$  k $\Omega$

**Detection levels**

**ON:**  $\geq 15$  V

**OFF:**  $\leq 9$  V

## OUTPUT SPECIFICATIONS

**Output:** Wet contact, 8 points

**Common:** All 8 points (24 terminals, common with the input)

**Output voltage:** 24 V DC  $\pm 10$  %

**Max. load current:** 150 mA per point, common

**Load resistance:** 160  $\Omega$  min.

## INSTALLATION

**Operating temperature:** -10 to +55°C (14 to 131°F)

**Operating humidity:** 30 to 90 %RH (non-condensing)

**Atmosphere:** No corrosive gas or heavy dust

**Mounting:** Installation Base (model: R3-BSx)

**Weight:** 200 g (0.44 lb)

## PERFORMANCE

**Output ON time accuracy:**  $\pm 10$  % max. for 1 sec. or less setting;  $\pm 0.1$  sec. max. for 1 sec. or more setting

**Data allocation:** 1

**Current consumption:** 350 mA

**Insulation resistance:**  $\geq 100$  M $\Omega$  with 500 V DC

**Dielectric strength:** 1500 V AC @ 1 minute (I/O to internal bus or internal power)

2000 V AC @ 1 minute (internal power to FG; isolated on the power supply module)

## FUNCTIONS

### ■ OUTPUT HOLD or OUTPUT OFF

In normal conditions, the module outputs the signal from the preferred bus A.

When an error is detected, the output is switched to the data from the bus B.

#### • Output Hold

If both are in error, the module holds the signal and stands by until one of the communications recovers.

#### • Output OFF

If both are in error, the module outputs OFF signals and stands by until one of the communications recovers.

At the startup, it outputs OFF until the communication is established and normal data is received.

### ■ MAX. ON POINTS AT ONCE

Function available for One-Shot Output Mode and ON/OFF

Control Output Mode.

Divide the points to be ON at once. When the total of load current exceeds the maximum load current, "Max. ON Points at Once" function is activated.

The number of the channel turned ON is output in order from the lowest.

Example: Max. ON Points at Once: 1 point; One-shot ON Time setting: 1 sec.

Ch1, 2, 4, 8 all ON: Ch1→Ch2→Ch4→Ch8 are turned ON in this order in a total time of 4 seconds.

Note: When writing in the same channel two or more times, check the previous output completion status to set the output.

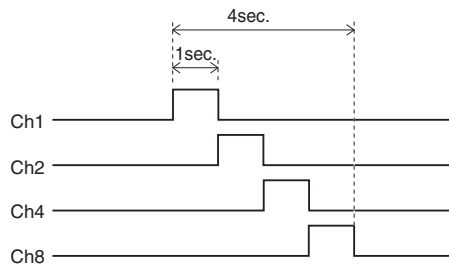

## EXTERNAL VIEW

### FRONT VIEW

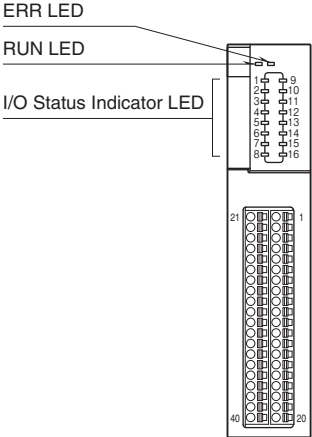

### SIDE VIEW

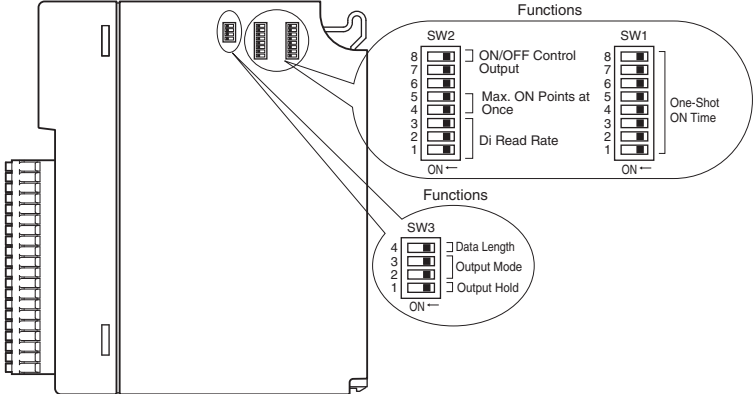

## I/O DATA DESCRIPTIONS

### ONE-SHOT OUTPUT MODE

8-bit output data (Do 1 through 8) and output (Ch1 through 8) are assigned 1:1.

Do	WRITE	ONE-SHOT OUTPUT/RESET	Di	OUTPUT COMPLETION STATUS
Do 1	1	Ch1 Output	Di 9	Ch1 Output Completion Status
	0	Ch1 Output Completion Reset		
Do 2	1	Ch2 Output	Di 10	Ch2 Output Completion Status
	0	Ch2 Output Completion Reset		
Do 3	1	Ch3 Output	Di 11	Ch3 Output Completion Status
	0	Ch3 Output Completion Reset		
Do 4	1	Ch4 Output	Di 12	Ch4 Output Completion Status
	0	Ch4 Output Completion Reset		
Do 5	1	Ch5 Output	Di 13	Ch5 Output Completion Status
	0	Ch5 Output Completion Reset		
Do 6	1	Ch6 Output	Di 14	Ch6 Output Completion Status
	0	Ch6 Output Completion Reset		
Do 7	1	Ch7 Output	Di 15	Ch7 Output Completion Status
	0	Ch7 Output Completion Reset		
Do 8	1	Ch8 Output	Di 16	Ch8 Output Completion Status
	0	Ch8 Output Completion Reset		

## ■ ON/OFF CONTROL OUTPUT MODE

### • Data Length: 8 bits

Do 1 through 8 are assigned to Ch1 through 8.

Do	WRITE	ONE-SHOT OUTPUT/RESET	Di	OUTPUT COMPLETION STATUS
Do 1 Do 2	0 0	Not Operating		
	1 0	Ch1 Output	Di 9	Ch1 Output Completion Status
	0 1	Ch2 Output	Di 10	Ch2 Output Completion Status
	1 1	Output Data Reset		
Do 3 Do 4	0 0	Not Operating		
	1 0	Ch3 Output	Di 11	Ch3 Output Completion Status
	0 1	Ch4 Output	Di 12	Ch4 Output Completion Status
	1 1	Output Data Reset		
Do 5 Do 6	0 0	Not Operating		
	1 0	Ch5 Output	Di 13	Ch5 Output Completion Status
	0 1	Ch6 Output	Di 14	Ch6 Output Completion Status
	1 1	Output Data Reset		
Do 7 Do 8	0 0	Not Operating		
	1 0	Ch7 Output	Di 15	Ch7 Output Completion Status
	0 1	Ch8 Output	Di 16	Ch8 Output Completion Status
	1 1	Output Data Reset		

The above table shows the case of Not Swapped (SW2-8: OFF). ON/OFF control output is swapped with its pair when SW2-8 is ON. The following is an example of Do 1 and Do 2.

Do	WRITE	ONE-SHOT OUTPUT/RESET	Di	OUTPUT COMPLETION STATUS
Do 1 Do 2	0 0	Not Operating		
	1 0	Ch2 Output	Di 10	Ch2 Output Completion Status
	0 1	Ch1 Output	Di 9	Ch1 Output Completion Status
	1 1	Output Data Reset		

### • Data Length: 4 bits

Do 1 through 4 are assigned to Ch1 through 8 as 1:2.

Do	WRITE	ONE-SHOT OUTPUT/RESET	Di	OUTPUT COMPLETION STATUS
Do 1	0	Ch1 Output	Di 9	Ch1 Output Completion Status
	1	Ch2 Output	Di 10	Ch2 Output Completion Status
Do 2	0	Ch3 Output	Di 11	Ch3 Output Completion Status
	1	Ch4 Output	Di 12	Ch4 Output Completion Status
Do 3	0	Ch5 Output	Di 13	Ch5 Output Completion Status
	1	Ch6 Output	Di 14	Ch6 Output Completion Status
Do 4	0	Ch7 Output	Di 15	Ch7 Output Completion Status
	1	Ch8 Output	Di 16	Ch8 Output Completion Status

The above table shows the case of Not Swapped (SW2-8: OFF). ON/OFF control output is swapped with its pair when SW2-8 is ON. The following is an example of Do 1.

Do	WRITE	ONE-SHOT OUTPUT/RESET	Di	OUTPUT COMPLETION STATUS
Do 1	0	Ch2 Output	Di 10	Ch2 Output Completion Status
	1	Ch1 Output	Di 9	Ch1 Output Completion Status

**■ CONTINUOUS OUTPUT MODE**

Do 1 through 8 are assigned to and Ch1 through 8. When data Do is “1” output is ON and when it is “0” output is OFF. Output completion status Di is related to Do.

Do	CONTINUOUS OUTPUT	Di	OUTPUT COMPLETION STATUS
Do 1	Ch1 Output	Di 9	Ch1 Output Completion Status
Do 2	Ch2 Output	Di 10	Ch2 Output Completion Status
Do 3	Ch3 Output	Di 11	Ch3 Output Completion Status
Do 4	Ch4 Output	Di 12	Ch4 Output Completion Status
Do 5	Ch5 Output	Di 13	Ch5 Output Completion Status
Do 6	Ch6 Output	Di 14	Ch6 Output Completion Status
Do 7	Ch7 Output	Di 15	Ch7 Output Completion Status
Do 8	Ch8 Output	Di 16	Ch8 Output Completion Status

**DATA ASSIGNMENT**

**■ Do**

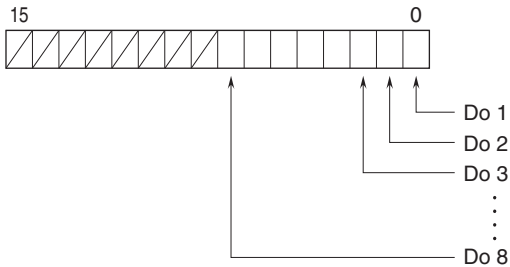

- Note 1: For 4-bit length ON/OFF control mode, Do 5 through Do 8 are unavailable.
- Note 2: For the combination with Modbus communication module (model: R3-NE1, R3-NM1 and such), use the addresses of Coil (0X) for Modbus I/O assignment.

**■ Di**

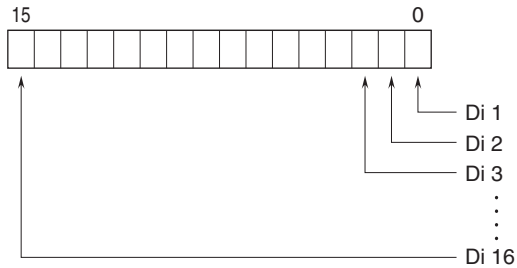

- Note 1: Di 9 – 16 data is not practical discrete input data. It is “output completion status” internal data.
- Note 2: For the combination with Modbus communication module (model: R3-NE1, R3-NM1 and such), use the addresses of Input (1X) for Modbus I/O assignment.

**EXTERNAL DIMENSIONS unit: mm (inch)**

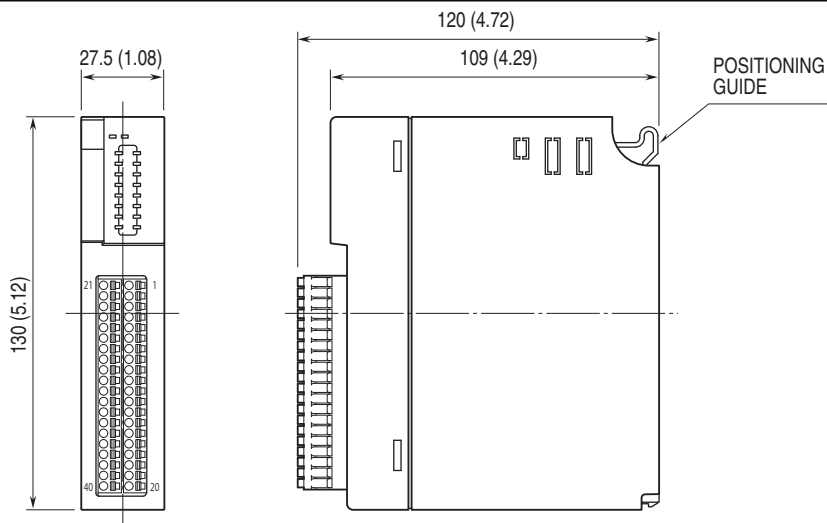

**SCHEMATIC CIRCUITRY & CONNECTION DIAGRAM**

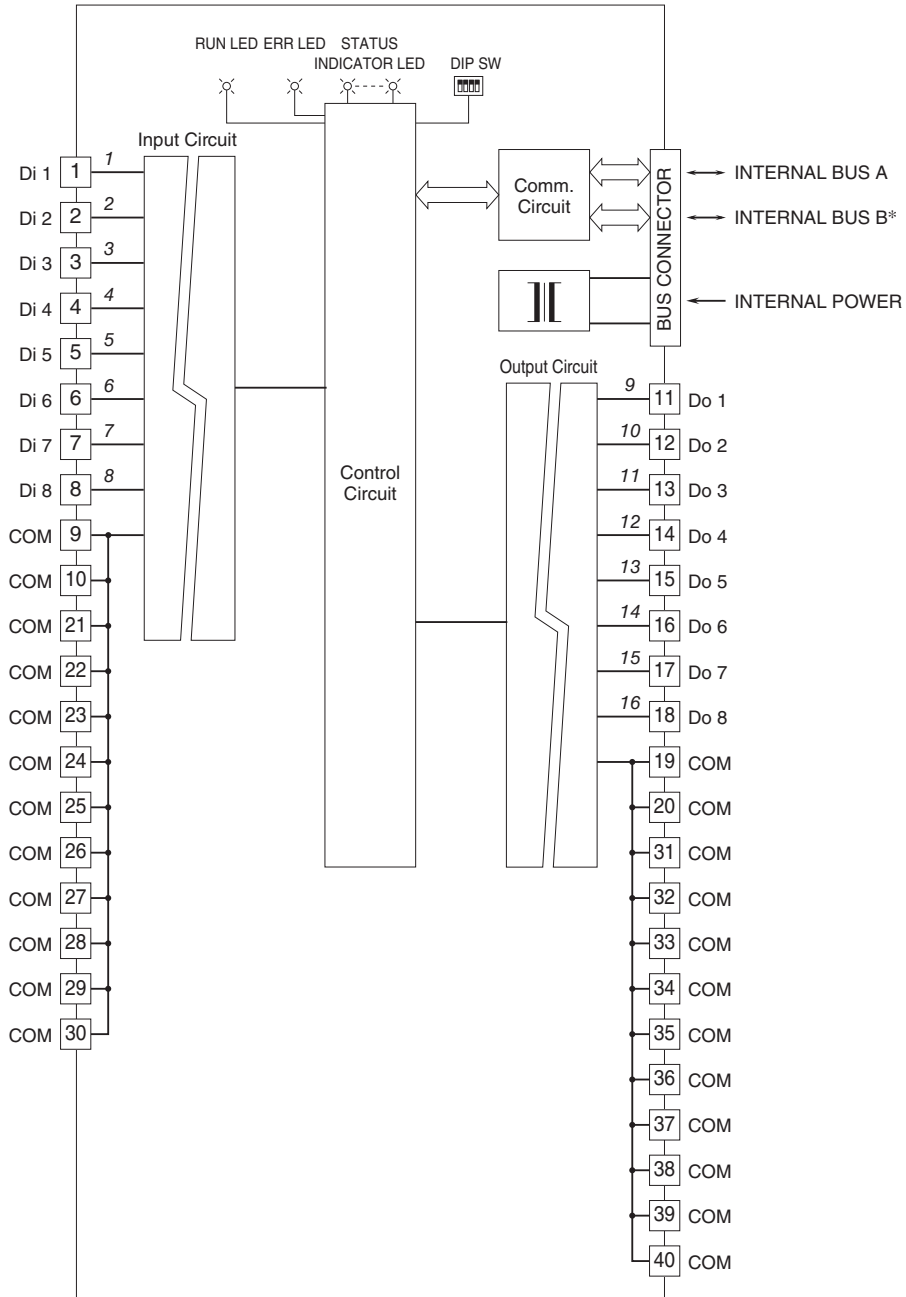

\* For dual redundant communication.  
 Numbers in italic indicate LED No.s assigned to the front panel LEDs.

■ Input Circuit

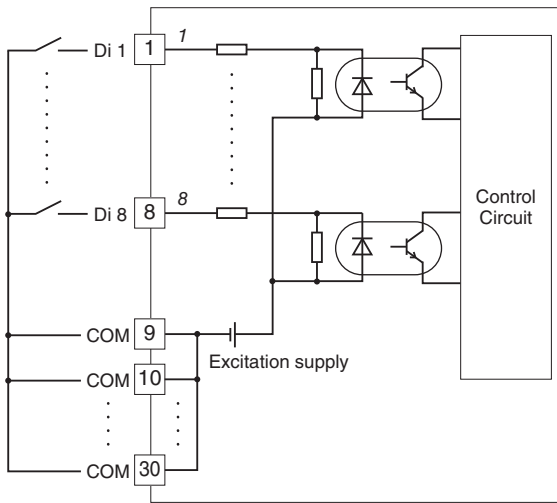

■ Output Circuit

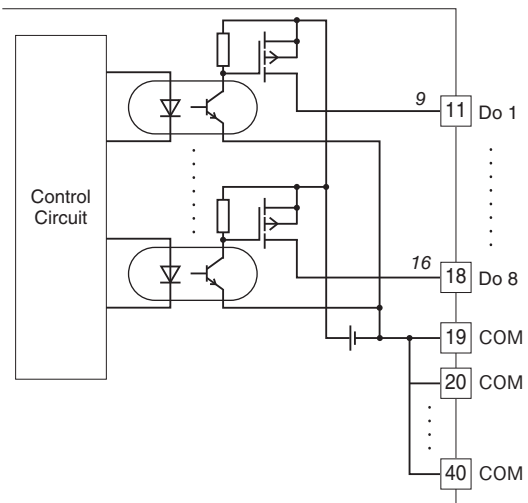

## I/O TERMINAL ASSIGNMENT

PIN No.	FUNCTION	PIN No.	FUNCTION
21	COM	1	Di 1
22	COM	2	Di 2
23	COM	3	Di 3
24	COM	4	Di 4
25	COM	5	Di 5
26	COM	6	Di 6
27	COM	7	Di 7
28	COM	8	Di 8
29	COM	9	COM
30	COM	10	COM
31	COM	11	Do 1
32	COM	12	Do 2
33	COM	13	Do 3
34	COM	14	Do 4
35	COM	15	Do 5
36	COM	16	Do 6
37	COM	17	Do 7
38	COM	18	Do 8
39	COM	19	COM
40	COM	20	COM



Specifications are subject to change without notice.