

Remote I/O R3 Series

DeviceNet INTERFACE MODULE

(for 32-point analog signals)

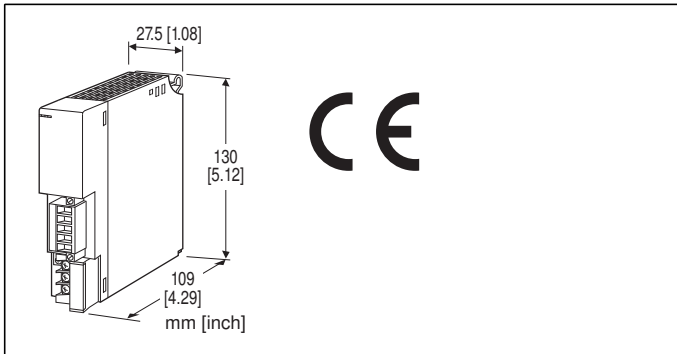

MODEL: R3-ND2-[1][2]

ORDERING INFORMATION

- Code number: R3-ND2-[1][2]
- Specify a code from below for each of [1] and [2].
(e.g. R3-ND2-R/CE/Q)
- Specify the specification for option code /Q
(e.g. /C01/SET)

[1] POWER INPUT

N: No power supply

AC Power

K3: 100 - 120 V AC

(Operational voltage range 85 - 132 V, 47 - 66 Hz) *

(CE not available)

L3: 200 - 240 V AC

(Operational voltage range 170 - 264 V, 47 - 66 Hz) *

(CE not available)

DC Power

R: 24 V DC

(Operational voltage range 24 V \pm 10 %, ripple 10 %p-p max.) *

* Not selectable for use with independent power modules or network modules with the internal power input options.

[2] OPTIONS (multiple selections)

Standards & Approvals

blank: Without CE

/CE: CE marking

Other Options

blank: none

/Q: Option other than the above (specify the specification)

SPECIFICATIONS OF OPTION: Q (multiple selections)

COATING (For the detail, refer to M-System's web site.)

/C01: Silicone coating

/C02: Polyurethane coating

/C03: Rubber coating

EX-FACTORY SETTING

/SET: Preset according to the Ordering Information Sheet
(No. ESU-8353)

RELATED PRODUCTS

- EDS file
(downloadable at M-System's web site.)

GENERAL SPECIFICATIONS

Connection

DeviceNet: Euro type connector terminal

(applicable wire size: 0.2 to 2.5 mm², stripped length 7 mm)

Internal bus: Via the Installation Base

(model: R3-BSx)

Internal power: Via the Installation Base (model: R3-BSx)

Power input, RUN contact output: M3 separable screw terminal (torque 0.5 N·m)

Screw terminal: Nickel-plated steel

Isolation: DeviceNet to internal bus or internal power to power input to RUN contact output to FG

Input error data setting: Input value setting at input module error with side DIP SW

Dual communication setting: Set with the side DIP switch

Data allocation setting: Set with the side DIP switch

■ RUN CONTACT OUTPUT

RUN contact: Turns ON when both MS and NS LEDs are green (DeviceNet in normal communication).

Rated load: 250 V AC @ 0.5 A (cos ϕ = 1)

30 V DC @ 0.5 A (resistive load)

(Less than 50 V AC to conform with EU Directive)

Maximum switching voltage: 250 V AC or 30 V DC

Maximum switching power: 250 VA or 150 W

Minimum load: 1 V DC @ 1 mA

Mechanical life: 2 \times 10⁷ cycles (300 cycles/min.)

When driving an inductive load, external contact protection and noise quenching recommended.

DeviceNet COMMUNICATION

Transmission cable: Approved for DeviceNet

Node address setting: DIP switch; 00 - 63

Baud rate: 125 kbps, 250 kbps, 500 kbps DIP switch

NS (Network Status) indicator: Bi-color (green/red) LED indicates status of the communication link.

MS (Module Status) indicator: Bi-color (green/red) LED indicates device status.

Data allocation: 32 words for input data 35 words for output data

INSTALLATION

Power consumption

•AC: Approx. 20 VA

•DC: Approx. 12 W

Current consumption (no power supply): 80 mA

Output current (power supply): 270 mA continuous at 20 V DC; 420 mA for 10 minutes

Supply voltage to network: 11 - 25 V DC supplied through the network terminal block

Supply current to network: 50 mA max.

Operating temperature: -10 to +55°C (14 to 131°F)

Operating humidity: 30 to 90 %RH (non-condensing)

Atmosphere: No corrosive gas or heavy dust

Mounting: Installation Base (model: R3-BSx)

Weight: 200 g (0.44 lb)

PERFORMANCE

Insulation resistance: $\geq 100 \text{ M}\Omega$ with 500 V DC

Dielectric strength: 1500 V AC @ 1 minute

(DeviceNet to internal bus or internal power to power input to RUN contact output to FG)

STANDARDS & APPROVALS

EU conformity:

EMC Directive

EMI EN 61000-6-4

EMS EN 61000-6-2

RoHS Directive

EXTERNAL VIEW

FRONT VIEW

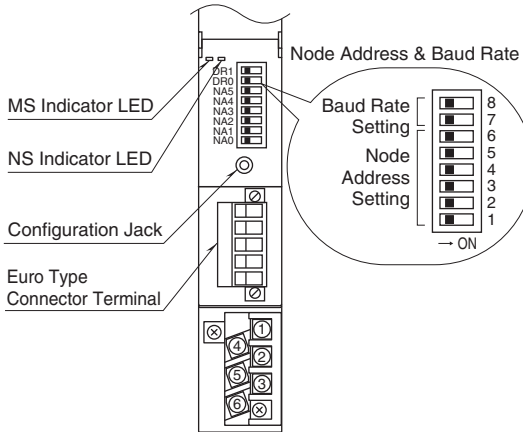

SIDE VIEW

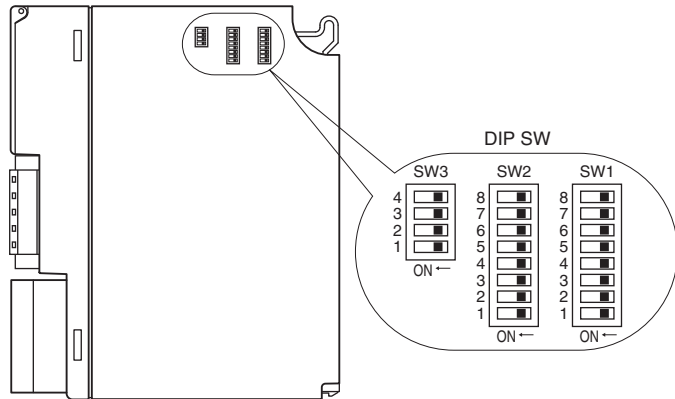

TRANSMISSION DATA DESCRIPTIONS

The DIP SW located at the side of the module specifies each I/O module's data allocation (occupied data area).
For example, when the data areas are assigned as shown below:

Module 1	4
Module 2	4
Module 3	4
Module 4	1
Module 5	1
Module 6	1
Module 7	1

Then the I/O data are assigned as in the figures below:

■ OUTPUT DATA

The figure below shows the allocation of the data sent from the network module to the master.

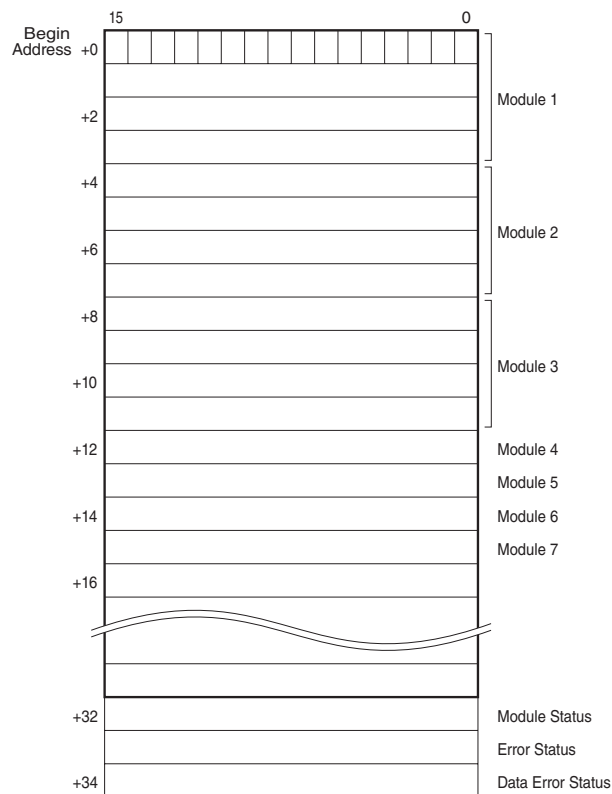

■ INPUT DATA

The figure below shows the allocation of the data sent from the master to the network module.

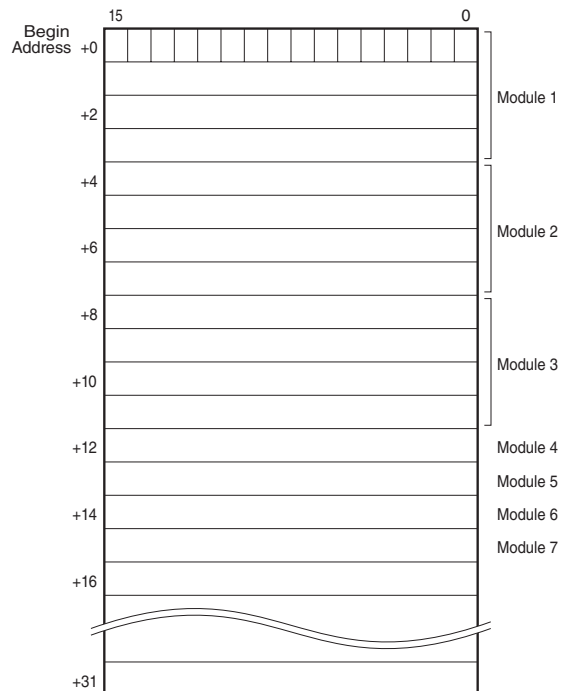

Module Status, Error Status and Data Error Status are assigned to +32, +33 and +34 respectively.

Each module can handle either input or output data. Input and output cannot be mixed in one module.

Input data from the master device is transferred to the module's output data area. The master device can read from the output data area the data it has set.

- Module Status indicates whether individual I/O modules are mounted or not. The bit corresponding to the mounted slot turns to "1," and the unmounted slot to "0."

- Error Status indicates error status for each module as described below. The bit corresponding to such module turns to "1."

R3-TSx, R3-RSx, R3-US4:	Input burnout
R3-DA16A:	Power input in error or disconnected
R3-YSx:	Output current error (e.g. load unconnected)
R3-PC16A:	External power supply in error or disconnected

- Data Error Status indicates overrange (R3-US4: out of -10% to +110%; the other types: out of -15% to +115%) status for each module. The bit corresponding to such module turns to "1."

MODULE STATUS, ERROR STATUS, DATA ERROR STATUS

Shows each module's availability and error status.

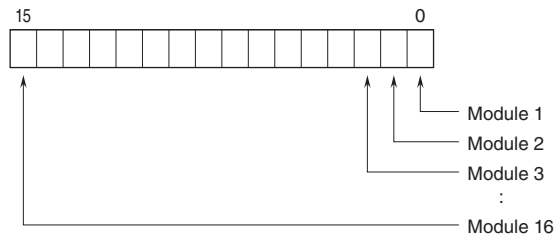

I/O DATA DESCRIPTIONS

The data allocations for typical I/O modules are shown below.
Refer to the manual for each module for detailed data allocations.

■ ANALOG DATA (16-bit data, models: R3-SV4, YV4, DS4, YS4, US4, etc.)

16-bit binary data.
Basically, 0 to 100% of the selected I/O range is converted into 0 to 10000 (binary).
-15 to 0 % is a negative range represented in 2's complement.
In case of R3-US4, -10 to 0% is a negative range represented in 2's complement.



■ TEMPERATURE DATA (16-bit data, models: R3-RS4, TS4, US4, etc.)

16-bit binary data.
With °C temperature unit, raw data is multiplied by 10. For example, 25.5°C is converted into 255.
With °F temperature unit, the integer section of raw data is directly converted into the data.
For example, 135.4°F is converted into 135.
Minus temperature is converted into negative values, represented in 2's complements.



■ ANALOG DATA (16-bit data, models: R3-CT4A, CT4B, etc.)

16-bit binary data.
Integer obtained by multiplying unit value (A) by 100.
In case of CLSE-R5, integer obtained by multiplying unit value (A) by 1000.

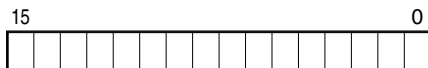

■ ACCUMULATED COUNT DATA (32-bit data, models: R3-PA2, PA4A, WT1, WT4, etc.)

32-bit binary data is used for accumulated counts and encoder positions.
Lower 16 bits are allocated from the lowest address to higher ones, higher 16 bits in turn.



■ BCD DATA (32-bit data, models: R3-BA32A, BC32A, etc.)

32-bit binary data is used for BCD.

Lower 16 bits are allocated from the lowest address to higher ones, higher 16 bits in turn.

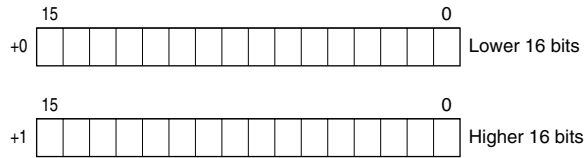

■ 16-POINT DISCRETE DATA (models: R3-DA16, DC16, etc.)

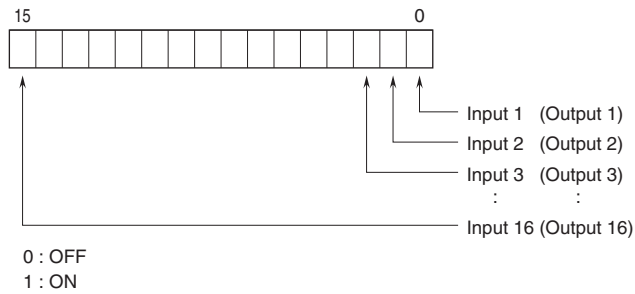

EXTERNAL DIMENSIONS & TERMINAL ASSIGNMENTS unit: mm [inch]

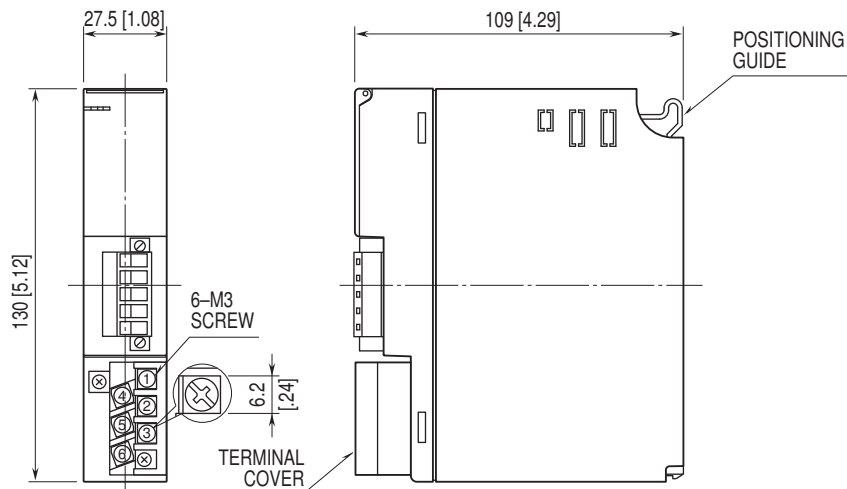

SCHEMATIC CIRCUITRY & CONNECTION DIAGRAM

Note: In order to improve EMC performance, bond the FG terminal to ground.

Caution: FG terminal is NOT a protective conductor terminal.

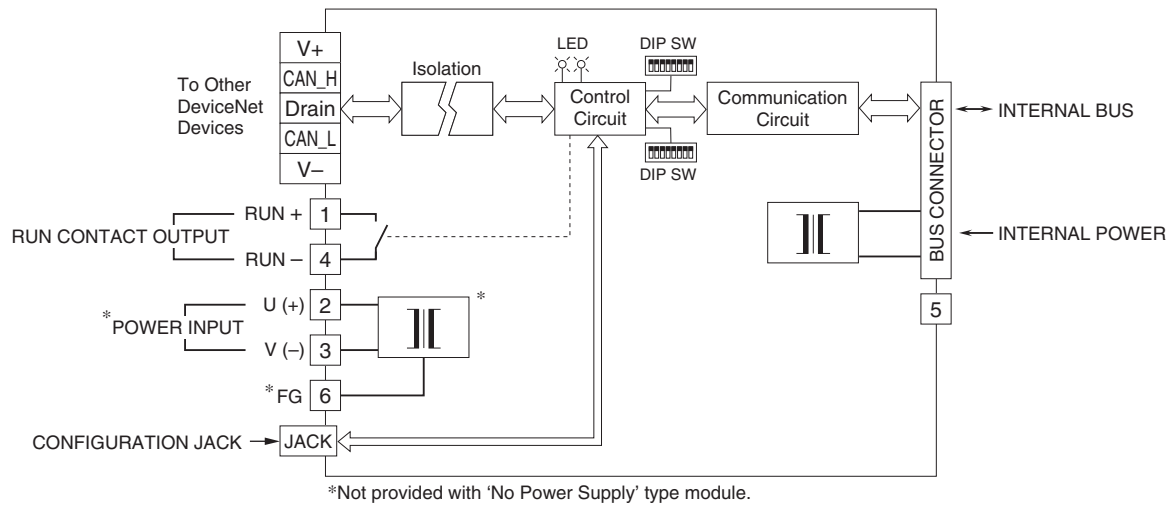

Specifications are subject to change without notice.