

Remote I/O R3 Series

NETWORK INTERFACE MODULE

(CC-Link IE Field network)

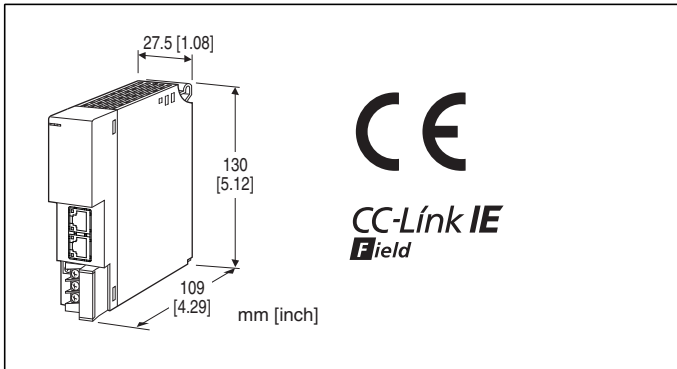

MODEL: R3-NCIE1[1]

ORDERING INFORMATION

- Code number: R3-NCIE1[1]
Specify a code from below for [1].
(e.g. R3-NCIE1/CE/W/Q)
- Specify the specification for option code /Q
(e.g. /C01)

[1] OPTIONS (multiple selections)

Standards & Approvals

blank: Without CE

/CE: CE marking

Mitsubishi PLC Redundant System

blank: Without

/W: With

Other Options

blank: none

/Q: Option other than the above (specify the specification)

SPECIFICATIONS OF OPTION: Q

COATING (For the detail, refer to M-System's web site.)

/C01: Silicone coating

/C02: Polyurethane coating

/C03: Rubber coating

RELATED PRODUCTS

- PC configurator software (model: R3CON)
Downloadable at M-System's web site.
For connecting to PC, use commercially available Mini-B type USB cable. (provided by user)

GENERAL SPECIFICATIONS

Connection

CC-Link IE Field: RJ-45 Modular Jack

Internal bus: Via the Installation Base (model: R3-BSx)

Internal power: Via the Installation Base (model: R3-BSx)

RUN contact output: M3 separable screw terminal (torque 0.5 N·m)

Screw terminal: Nickel-plated steel

Isolation: CC-Link IE Field to internal bus or internal power to RUN contact output

Input error data setting: Input value setting at input module error with side DIP SW

Dual communication setting: Set with the side DIP switch

Data allocation setting: Set with the side DIP switch

RUN indicator: Green LED ON at normal operating

ERR indicator: Red LED ON at abnormal node

■ RUN CONTACT OUTPUT

RUN contact: Turns ON while the green RUN LED is ON (ON in normal operation).

Rated load: 250 V AC @ 0.5 A (cos ϕ = 1)
30 V DC @ 0.5 A (resistive load)

(Less than 50 V AC to conform with EU Directive)

Maximum switching voltage: 250 V AC or 30 V DC

Maximum switching power: 250 VA or 150 W

Minimum load: 1 V DC @ 1 mA

Mechanical life: 2×10^7 cycles (300 cycles/min.)

When driving an inductive load, external contact protection and noise quenching recommended.

CC-Link IE Field COMMUNICATION

Protocol: IEEE 802.3

Transmission type: 1000BASE-T

Communication speed: 1 Gbps

Network cable: Cable conformed to CC-Link IE Field

Double shielded twist pair cable (CAT5e)

RJ-45 connector

Network topology: Line, star and ring

Max. number stations: 120 (Total slave station)

(Number of max. connectable slaves may vary depending on the master module. Refer to the instruction manual of the master module)

Max. station-to-station distance: 100 m

Station type: Remote device station

Link device: RX/Ry 128 points, RWw/RWr 64 points

NetWork No.: 1 to 239; Selectable with PC Configurator Software (model: R3CON) (factory default: 1)

INSTALLATION

Current consumption: 170 mA max.

Operating temperature: -10 to +55°C (14 to 131°F)

Operating humidity: 30 to 90 %RH (non-condensing)

Atmosphere: No corrosive gas or heavy dust

Mounting: Installation Base (model: R3-BSx)

Weight: 190 g (0.42 lb)

PERFORMANCE

Insulation resistance: $\geq 100 \text{ M}\Omega$ with 500 V DC

Dielectric strength: 1500 V AC @ 1 minute (CC-Link IE Field to internal bus or internal power to RUN contact output)

1500 V AC @ 1 minute (power input to FG; isolated on the power supply module)

STANDARDS & APPROVALS

EU conformity:

EMC Directive

EMI EN 61000-6-4

EMS EN 61000-6-2

RoHS Directive

EXTERNAL VIEW

FRONT VIEW

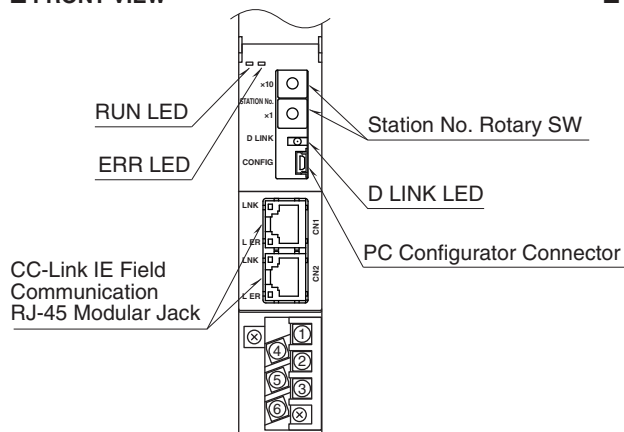

SIDE VIEW

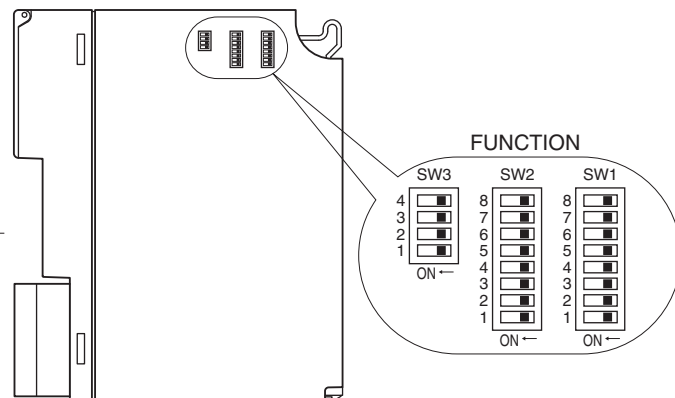

TRANSMISSION DATA DESCRIPTIONS

Number of transmission data (data allocation) for each I/O module is set with the DIP switch on the side of the unit. Data allocation is assigned from slot 1 in sequence.

Keep number of transmission data of I/O module under 64, because max. number of transmission data is 64 per a node.

Station type: Remote device station

Link device: RX/RX 128points, RWw/RWr 64points

E.g. I/O data is assigned as shown below in the case of following configuration.

BASE	SLOT NO.	MODEL	NUMBER OF TRANSMISSION DATA
R3-BS10	1	R3-DA16A	1
	2	R3-DC16A	1
	3	R3-SV4	4
	4	R3-YV4	4
	5	R3-RS8	8
	6	R3-YV8	8
	7	R3-PA16	16
	8	R3-PC16A	16
	9	R3-NCIE1	-
	10	R3-PS1	-

■ INPUT DATA

The figure below shows the data sent from the device to the master.

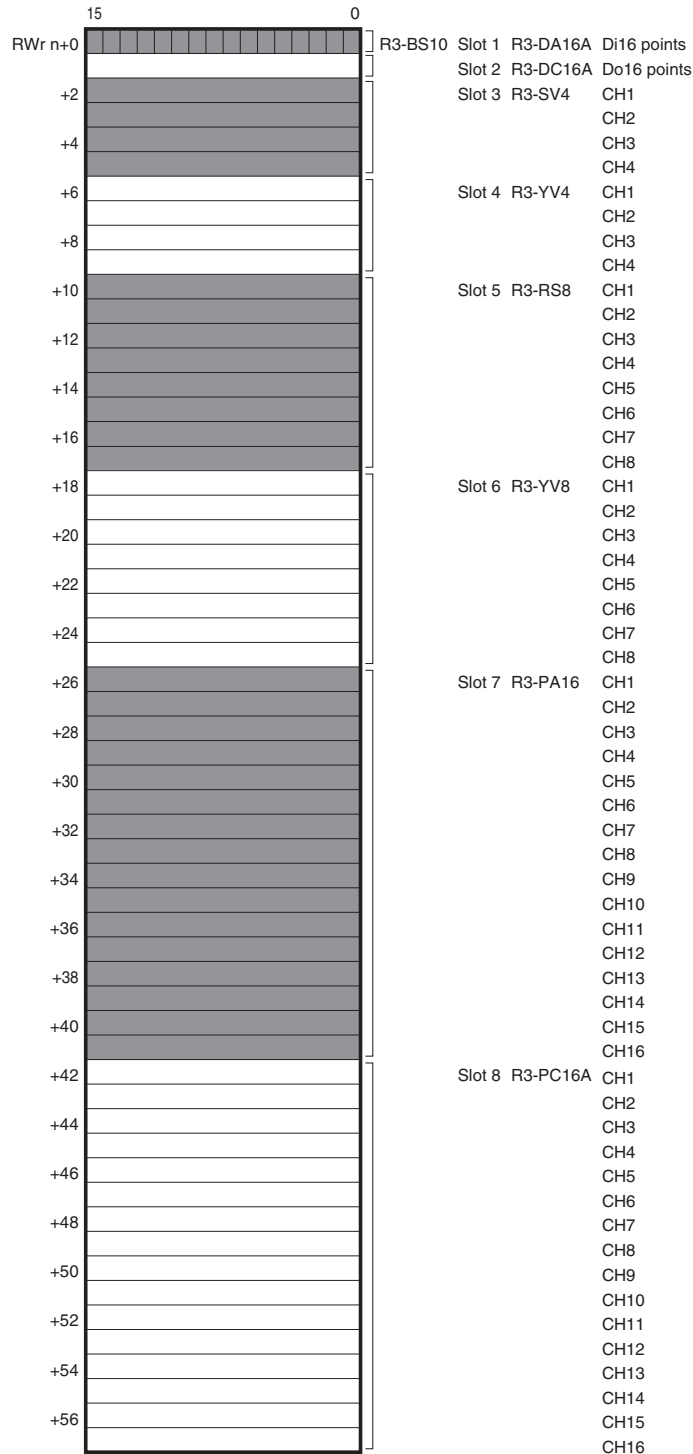

■ OUTPUT DATA

The figure below shows the data received from the master.

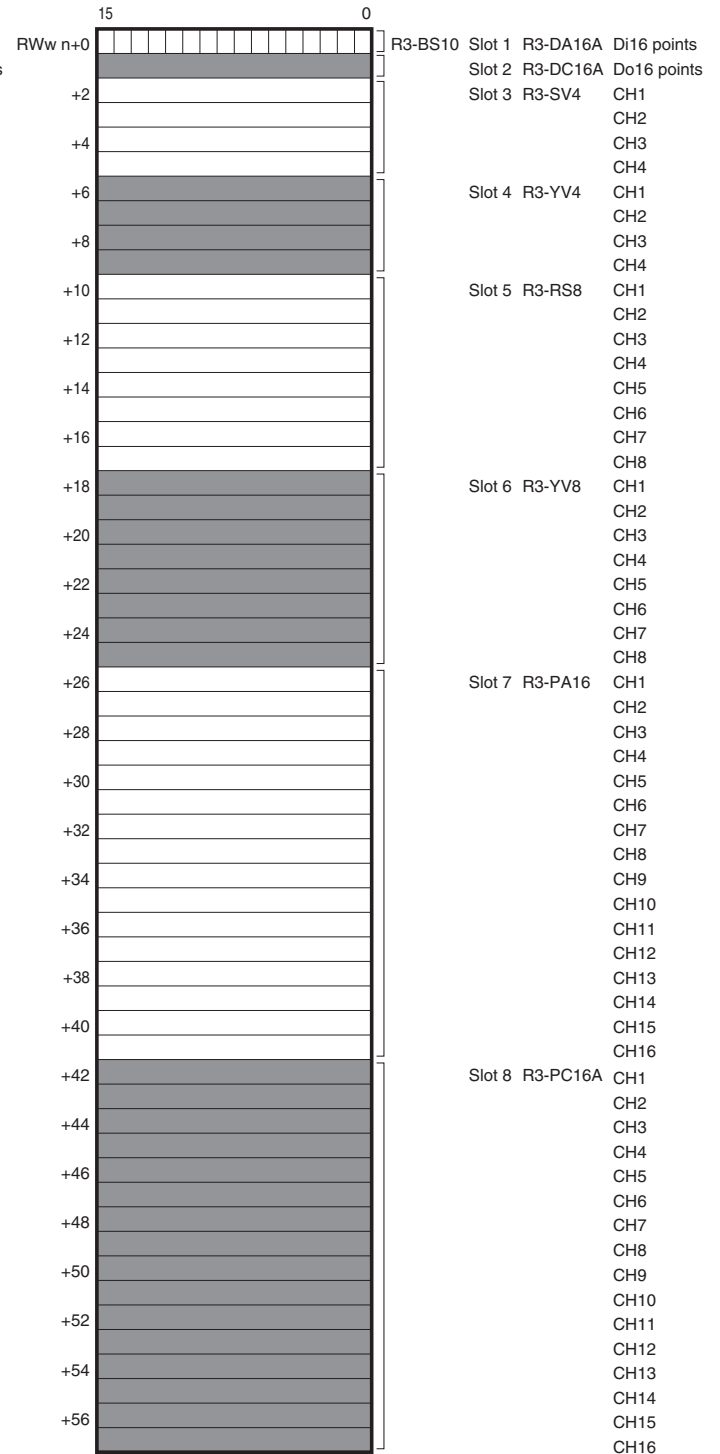

■ REMOTE INPUT

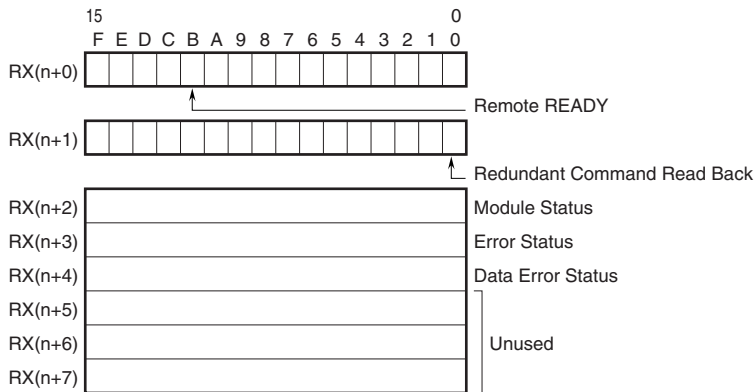

- RX(n+0) is used as Ready signal, the bit is “1” when this module is in normal.
- Redundant Command Read Back (Opt. code: /W Available only for redundant system PLC by Mitsubishi)
The bit written to RY(n+1)0 reads back to RX(n+1)0.
- Module Status
RX(n+2)0 to RX(n+2)F indicate whether individual I/O modules of R3 series are mounted or not.
The bit corresponding to the mounted slot turns to “1,” and the unmounted slot to “0”
- Error Status
RX(n+3)0 to RX(n+3)F indicate error status for each module of R3 series.
The bit corresponding to such module turns to “1,” as described below.
R3-TSx, R3-RSx, R3-US4 Input burnout.
R3-DA16A input power in error or disconnected
R3-YSx output current error (e.g. load unconnected)
R3-PC16A external power supply in error or disconnected
- Data Error Status
RX(n+4)0 to RX(n+4)F indicate data error status for each module of R3 series.
The bit corresponding to such module turns to “1,” as described below.
Input value is out of -15% to +115%
In the case of R3-US4 (voltage input) input level out of -10% to +110%.

RX(n+2)0, RX(n+3)0, RX(n+4)0	slot 1
RX(n+2)1, RX(n+3)1, RX(n+4)1	slot 2
RX(n+2)2, RX(n+3)2, RX(n+4)2	slot 3
⋮	⋮
RX(n+2)F, RX(n+3)F, RX(n+4)F	slot 16

Link devices other than the above are not in use.

■ REMOTE OUTPUT (Opt. code: /W Available only for redundant system PLC by Mitsubishi)

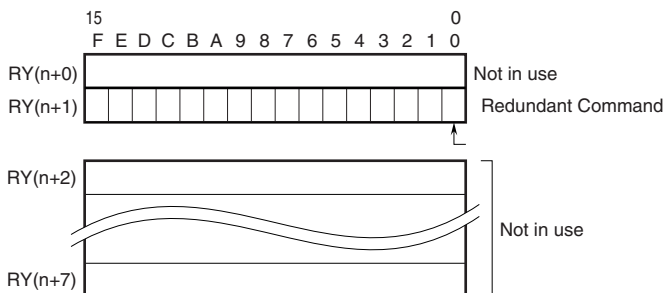

• Redundant Command

Bit 0 of RY(n+1) is assigned to designate control system or standby system. Set this bit from the host PLC to switch from the PLC master control system to the standby system, or vice versa. The R3 module output (slave station) is controlled according to the bit combinations as shown in the table below. No switching is required for the R3 input modules which continuously send out data to both 'main' and 'sub' network modules.

RY(n+1) 0 = 0 : PLC master control system

RY(n+1) 0 = 1 : PLC standby system

R3 MAIN (RY(n+1) 0)	R3 SUB (RY(n+1) 0)	CONTROL
0	0	Output from the 'main' network module
0	1	Output from the 'main' network module
1	0	Output from the 'sub' network module
1	1	Output hold or output off*1

*1. Depending on the setting for the output hold function of output module.

• Operation

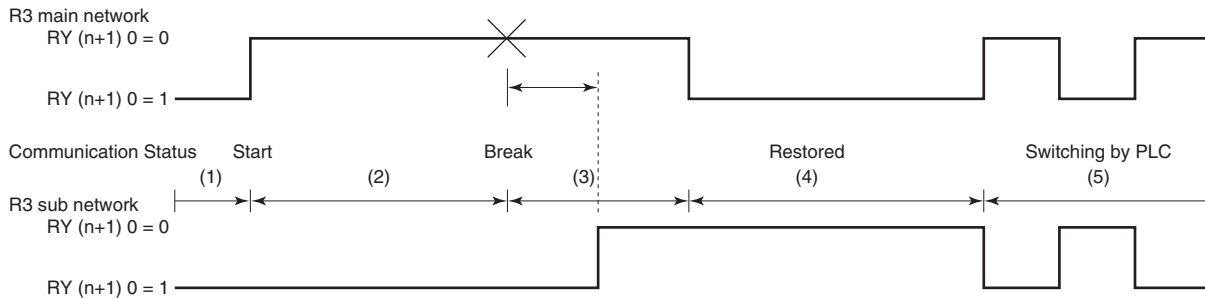

- 1) When the redundant command bits are undefined due to no communication, the both PLCs function as standby system for each of R3 main and sub network modules. The output module's status turns to 'output hold' or 'output off' according to the setting for output hold function. During no communication just after the power supply, all the channels of the contact output modules are off-state, and analog output modules output -15%.
- 2) The master PLC communicates with the R3 main network module, while the standby PLC communicates with the R3 sub network module.
- 3) When a wire breakdown is detected at the R3 main network, the output signal is held for the preset time period (Timer is programmable with the PC Configurator Software, R3CON). After the time has been elapsed, the output is switched from the R3 main to R3 sub network. Be sure to set an appropriate output signal to the R3 sub network before the switching. The host PLC for the R3 main network is now functioning as standby system.
- 4) Once the PLC control is transferred to the standby system, it is necessary to set RY(n+1) 0 = 1 to the R3 main network in order to prevent R3 output control automatically switched to the main network when the R3 main network is restored. If it is set to RY(n+1) 0 = 0, the R3 output will be switched to the main network even when the PLC control is in the standby system.
- 5) When both R3 main and R3 sub network modules are in communication, the output can be switched without delay by setting RY(n+1) 0 values. Be sure to set an appropriate output signal to the network module before the control is switched to it.

■ CONNECTION EXAMPLE

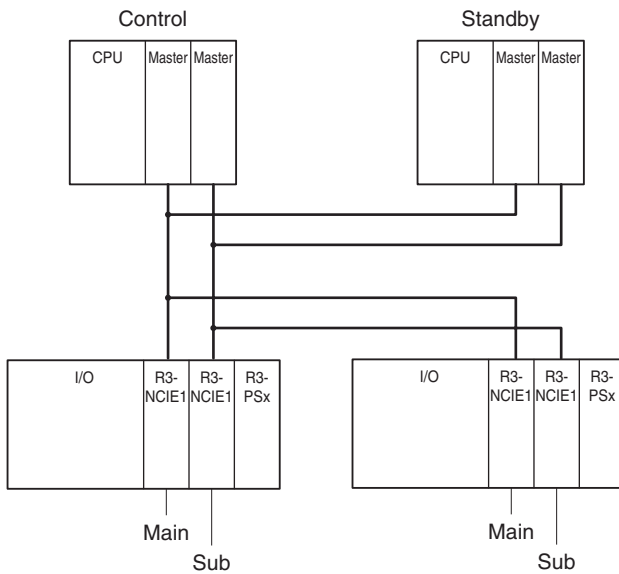

Link devices other than the above are not in use.

MODULE STATUS, ERROR STATUS, DATA ERROR STATUS

Shows each module's availability and error status.

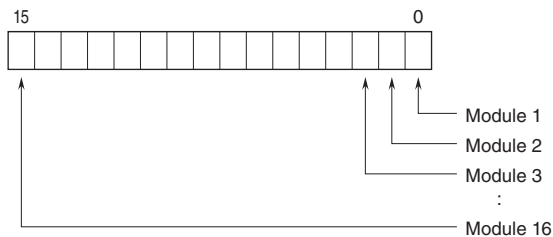

I/O DATA DESCRIPTIONS

The data allocations for typical I/O modules are shown below.
Refer to the manual for each module for detailed data allocations.

■ OPERATION IN CASE OF A COMMUNICATION ERROR WITH I/O MODULES

When the communication between the network module and the I/O modules is lost due to an error in an input module, the last process values are held until the communication is re-established.

■ ANALOG DATA (16-bit data, models: R3-SV4, YV4, DS4, YS4, US4, etc.)

16-bit binary data.
Basically, 0 to 100% of the selected I/O range is converted into 0 to 10000 (binary).
-15 to 0 % is a negative range represented in 2's complement.
In case of R3-US4, -10 to 0% is a negative range represented in 2's complement.



■ TEMPERATURE DATA (16-bit data, models: R3-RS4, TS4, US4, etc.)

16-bit binary data.

With °C temperature unit, raw data is multiplied by 10. For example, 25.5°C is converted into 255.

With °F temperature unit, the integer section of raw data is directly converted into the data.

For example, 135.4°F is converted into 135.

Minus temperature is converted into negative values, represented in 2's complements.



■ ANALOG DATA (16-bit data, models: R3-CT4A, CT4B, etc.)

16-bit binary data.

Integer obtained by multiplying unit value (A) by 100.

In case of CLSE-R5, integer obtained by multiplying unit value (A) by 1000.



■ ACCUMULATED COUNT DATA (32-bit data, models: R3-PA2, PA4A, WT1, WT4, etc.)

32-bit binary data is used for accumulated counts and encoder positions.

Lower 16 bits are allocated from the lowest address to higher ones, higher 16 bits in turn.

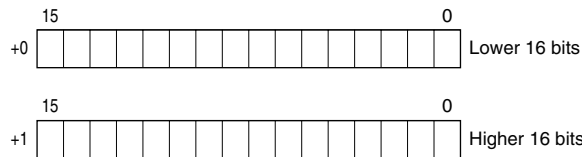

■ BCD DATA (32-bit data, models: R3-BA32A, BC32A, etc.)

32-bit binary data is used for BCD.

Lower 16 bits are allocated from the lowest address to higher ones, higher 16 bits in turn.

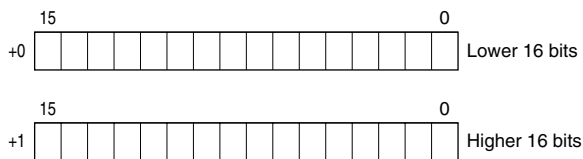

■ 16-POINT DISCRETE DATA (models: R3-DA16, DC16, etc.)

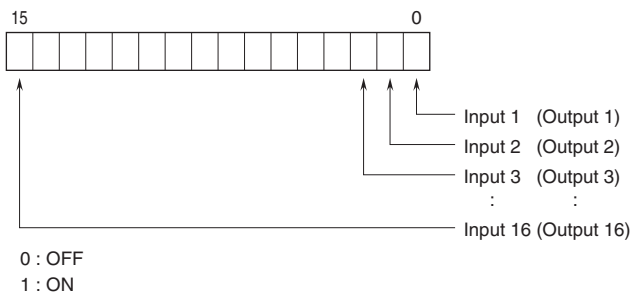

EXTERNAL DIMENSIONS & TERMINAL ASSIGNMENTS unit: mm [inch]

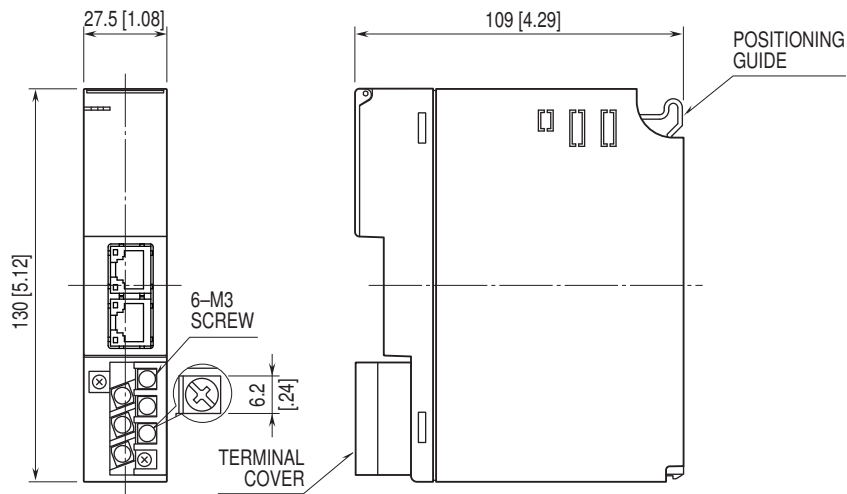

SCHEMATIC CIRCUITRY & CONNECTION DIAGRAM

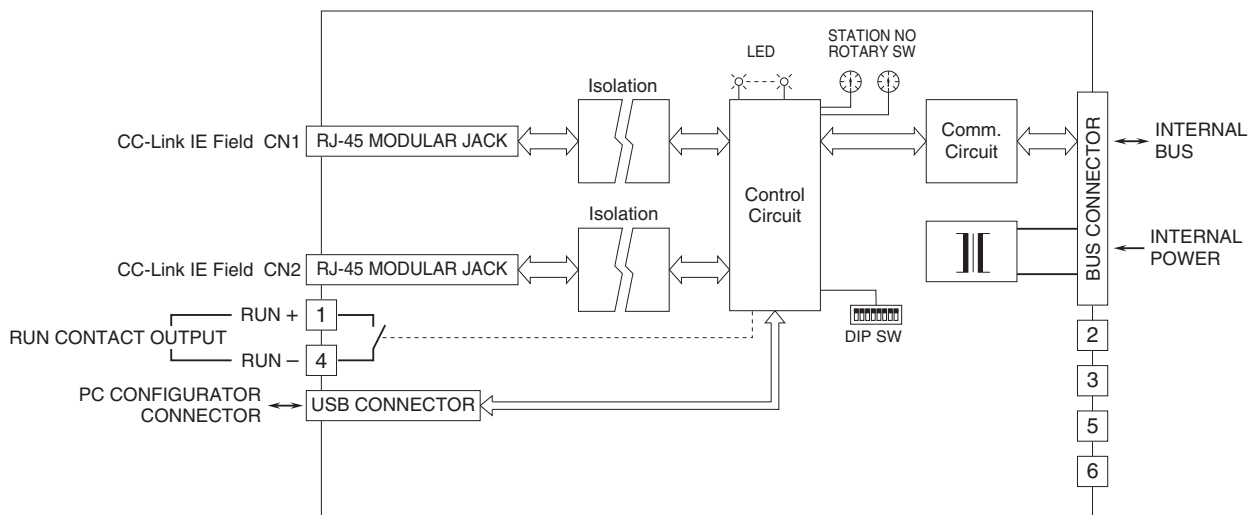

Regarding CN1 and CN2 of RJ-45 connector for CC-Link IE Field network, there is no restriction for connection order.



Specifications are subject to change without notice.