

## Remote I/O R3 Series

### CC-Link INTERFACE MODULE

(CC-Link Ver. 2)

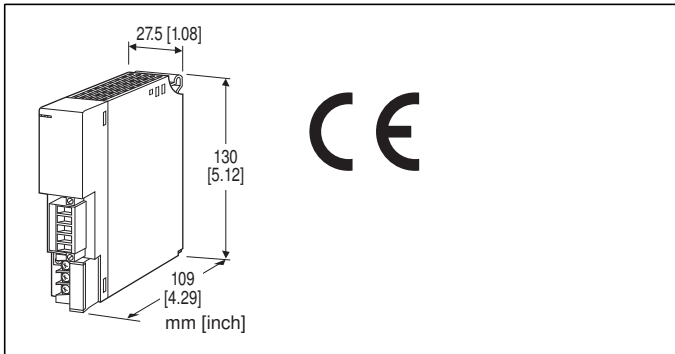

### MODEL: R3-NC3-[1][2]

#### ORDERING INFORMATION

- Code number: R3-NC3-[1][2]
- Specify a code from below for each of [1] and [2].  
(e.g. R3-NC3-N/CE/W/Q)
- Specify the specification for option code /Q  
(e.g. /C01/SET)

#### [1] POWER INPUT

**N:** No power supply

##### AC Power

**K3:** 100 - 120 V AC

(Operational voltage range 85 - 132 V, 47 - 66 Hz) \*  
(CE not available)

**L3:** 200 - 240 V AC

(Operational voltage range 170 - 264 V, 47 - 66 Hz) \*  
(CE not available)

##### DC Power

**R:** 24 V DC

(Operational voltage range 24 V  $\pm$ 10 %, ripple 10 %p-p max.) \*

\* Not selectable for use with independent power modules or network modules with the internal power input options.

#### [2] OPTIONS (multiple selections)

##### Standards & Approvals

**blank:** Without CE

**/CE:** CE marking

##### Mitsubishi PLC Redundant System

**blank:** Without

**/W:** With

##### Other Options

**blank:** none

**/Q:** Option other than the above (specify the specification)

#### SPECIFICATIONS OF OPTION: Q (multiple selections)

##### COATING (For the detail, refer to M-System's web site.)

**/C01:** Silicone coating

**/C02:** Polyurethane coating

**/C03:** Rubber coating

##### EX-FACTORY SETTING

**/SET:** Preset according to the Ordering Information Sheet  
(No. ESU-8422)

#### PACKAGE INCLUDES...

- Terminating resistor (110  $\Omega$ , 0.5 W)

#### GENERAL SPECIFICATIONS

##### Connection

**CC-Link:** Euro type connector terminal

(applicable wire size: 0.2 to 2.5 mm<sup>2</sup>, stripped length 7 mm)

**Internal bus:** Via the Installation Base

(model: R3-BSx)

**Internal power:** Via the Installation Base (model: R3-BSx)

**Power input, RUN contact output:** M3 separable screw terminal (torque 0.5 N·m)

**Screw terminal:** Nickel-plated steel

**Isolation:** CC-Link to internal bus or internal power to power supply to RUN contact output to FG

**Dual communication setting:** Set with the side DIP switch

**Data allocation setting:** Set with the side DIP switch

**RUN indicator:** Bi-color (green/red) LED; Green ON in normal communication; Red ON when receiving data (Function selected with DIP SW)

**ERR indicator:** Bi-color (green/red) LED;

Green ON or blinking at communication error (OFF with cable disconnection, blinking in setting error); Red ON at transmitting data (Function selected with DIP SW)

##### ■ RUN CONTACT OUTPUT

**RUN contact:** Turns ON while the green RUN LED is ON (CC-Link in normal communication).

**Rated load:** 250 V AC @ 0.5 A (cos  $\phi$  = 1)

30 V DC @ 0.5 A (resistive load)

(Less than 50 V AC to conform with EU Directive)

**Maximum switching voltage:** 250 V AC or 30 V DC

**Maximum switching power:** 250 VA or 150 W

**Minimum load:** 1 V DC @ 1 mA

**Mechanical life:** 2  $\times$  10<sup>7</sup> cycles (300 cycles/min.)

When driving an inductive load, external contact protection and noise quenching recommended.

#### CC-Link COMMUNICATION

**CC-Link:** Conforms to Version 2.00

(incompatible with Ver. 1)

**Cyclic expansion setting:** 2, 4, 8 folds (Function selected with DIP switch)

**Station No. setting:** Rotary switch; 1 - 64

**Baud rate setting:** Rotary switch

156kbps, 625kbps, 2.5Mbps, 5Mbps, 10Mbps

**Station type:** Remote device station

**Data allocation:** 4 (112 I/O points, 16 words) × m  
(m = Cyclic expansion setting)

**Transmission cable:** Approved for CC-Link

## INSTALLATION

**Power consumption**

•AC: Approx. 20 VA

•DC: Approx. 12 W

**Current consumption (no power supply):** 120 mA

**Output current (power supply):** 250 mA continuous at 20 V  
DC; 400 mA for 10 minutes

**Operating temperature:** -10 to +55°C (14 to 131°F)

**Operating humidity:** 30 to 90 %RH (non-condensing)

**Atmosphere:** No corrosive gas or heavy dust

**Mounting:** Installation Base (model: R3-BSx)

**Weight:** 200 g (0.44 lb)

## PERFORMANCE

**Insulation resistance:** ≥ 100 MΩ with 500 V DC

**Dielectric strength:** 1500 V AC @ 1 minute (CC-Link to  
internal bus or internal power to power input to RUN contact  
output to FG)

## STANDARDS & APPROVALS

**EU conformity:**

EMC Directive

EMI EN 61000-6-4

EMS EN 61000-6-2

RoHS Directive

## EXTERNAL VIEW

### FRONT VIEW

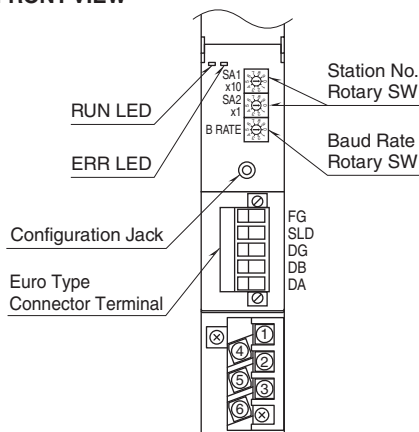

### SIDE VIEW

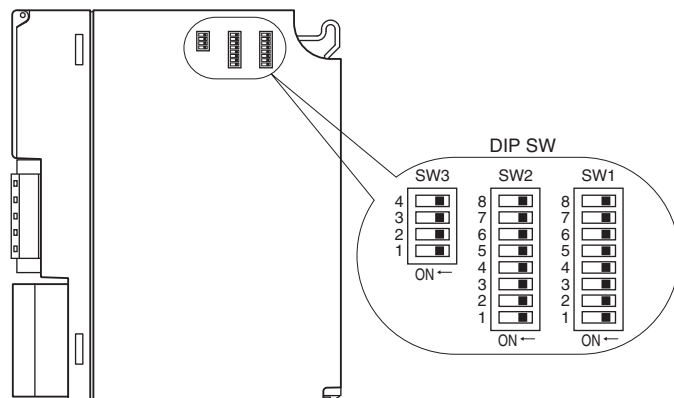

## COMMUNICATION CABLE CONNECTIONS

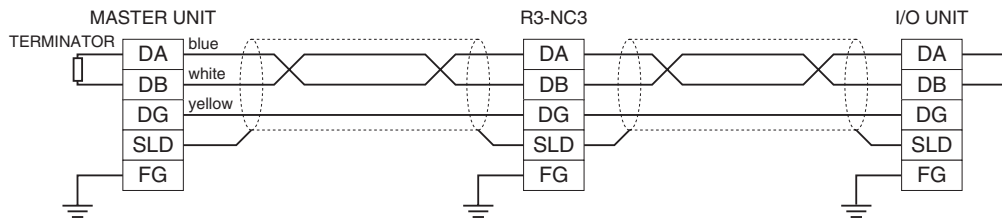

## TRANSMISSION DATA DESCRIPTIONS

The DIP SW located at the side of the module specifies each I/O module's data allocation (occupied data area).  
For example, when the data areas are assigned as shown below:

Module 1	4
Module 2	4
Module 3	4
Module 4	1
Module 5	1
Module 6	1
Module 7	1

Then the I/O data are assigned as in the figures below:

### ■ OUTPUT DATA

The figure below shows the allocation of the data sent from the network module to the master.

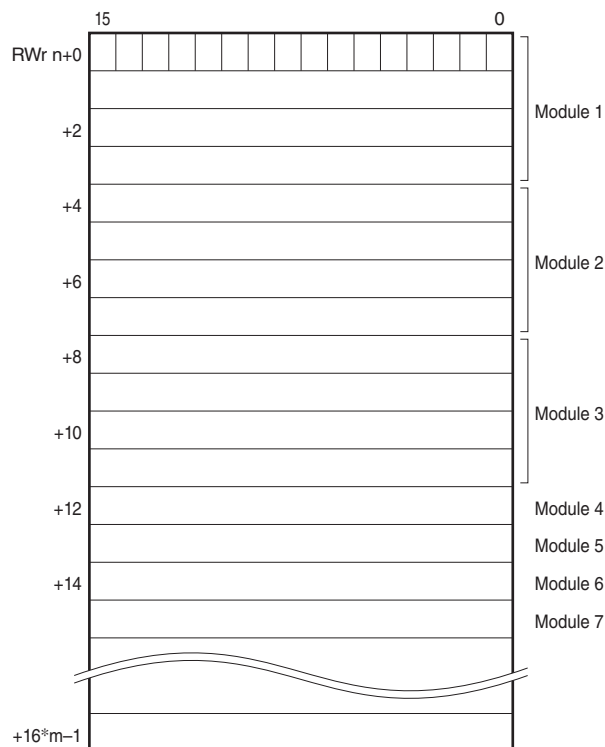

### ■ INPUT DATA

The figure below shows the allocation of the data sent from the master to the network module.

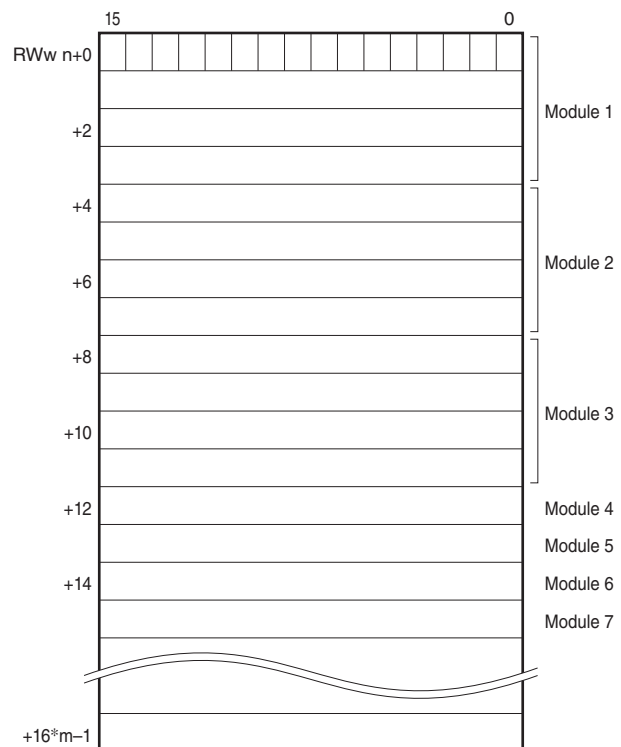

[16\*m] (m = cyclic expansion setting) data areas are available. Total data areas occupied by I/O modules must be within this limitation.

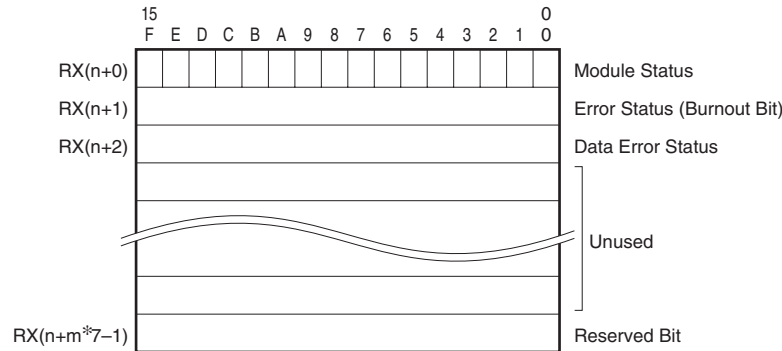

- **Module Status**

RX(n+0)0 through RX(n+0)F indicate whether individual I/O modules are mounted or not. The bit corresponding to the mounted slot turns to “1,” and the unmounted slot to “0.”

- **Error Status**

RX(n+1)0 through RX(n+1)F indicate error status for each module as described below. The bit corresponding to such module turns to “1.”

R3-TSx, -RSx, -US4:	Input burnout
R3-DA16A:	Power input in error or disconnected
R3-YSx:	Output current error (e.g. load unconnected)
R3-PC16A:	External power supply in error or disconnected

- **Data Error Status**

RX(n+2)0 through RX(n+2)F indicate overrange (R3-US4: out of -10% to +110%; the other types: out of -15% to +115%) status for each module. The bit corresponding to such module turns to “1.”

- RX(n+3) through RX(n+m\*7-2) are unused.

- RX(n+m\*7-1)0 through RX(n+m\*7-1)7 are reserved for future use. RX(n+m\*7-1)B is assigned to Ready signal, which is turned to “1” when the network module is in normal conditions. RX(n+m\*7-1)8 through RX(n+m\*7-1)A, RX(n+m\*7-1)C through RX(n+m\*7-1)F are not used.

RX(n+0) 0, RX(n+1) 0, RX(n+2) 0	Module 1
RX(n+0) 1, RX(n+1) 1, RX(n+2) 1	Module 2
RX(n+0) 2, RX(n+1) 2, RX(n+2) 2	Module 3
:	:
RX(n+0) F, RX(n+1) F, RX(n+2) F	Module 16

## MODULE STATUS, ERROR STATUS, DATA ERROR STATUS

Shows each module's availability and error status.

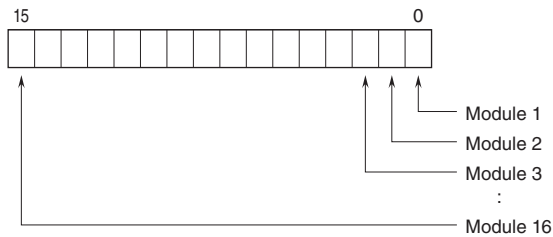

## I/O DATA DESCRIPTIONS

The data allocations for typical I/O modules are shown below.  
Refer to the manual for each module for detailed data allocations.

### ■ OPERATION IN CASE OF A COMMUNICATION ERROR WITH I/O MODULES

When the communication between the network module and the I/O modules is lost due to an error in an input module, the last process values are held until the communication is re-established.

### ■ ANALOG DATA (16-bit data, models: R3-SV4, YV4, DS4, YS4, US4, etc.)

16-bit binary data.  
Basically, 0 to 100% of the selected I/O range is converted into 0 to 10000 (binary).  
-15 to 0 % is a negative range represented in 2's complement.  
In case of R3-US4, -10 to 0% is a negative range represented in 2's complement.

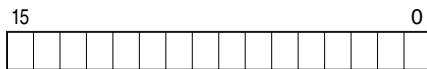

### ■ TEMPERATURE DATA (16-bit data, models: R3-RS4, TS4, US4, etc.)

16-bit binary data.  
With °C temperature unit, raw data is multiplied by 10. For example, 25.5°C is converted into 255.  
With °F temperature unit, the integer section of raw data is directly converted into the data.  
For example, 135.4°F is converted into 135.  
Minus temperature is converted into negative values, represented in 2's complements.



### ■ ANALOG DATA (16-bit data, models: R3-CT4A, CT4B, etc.)

16-bit binary data.  
Integer obtained by multiplying unit value (A) by 100.  
In case of CLSE-R5, integer obtained by multiplying unit value (A) by 1000.



### ■ ACCUMULATED COUNT DATA (32-bit data, models: R3-PA2, PA4A, WT1, WT4, etc.)

32-bit binary data is used for accumulated counts and encoder positions.  
Lower 16 bits are allocated from the lowest address to higher ones, higher 16 bits in turn.

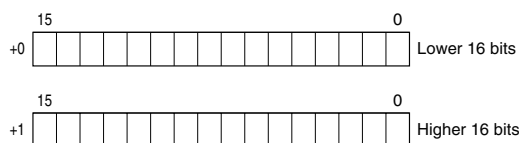

■ **BCD DATA (32-bit data, models: R3-BA32A, BC32A, etc.)**

32-bit binary data is used for BCD.

Lower 16 bits are allocated from the lowest address to higher ones, higher 16 bits in turn.

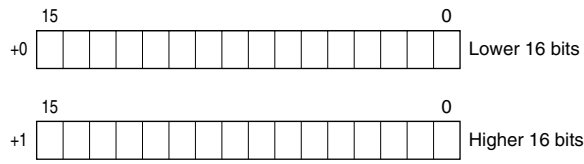

■ **16-POINT DISCRETE DATA (models: R3-DA16, DC16, etc.)**

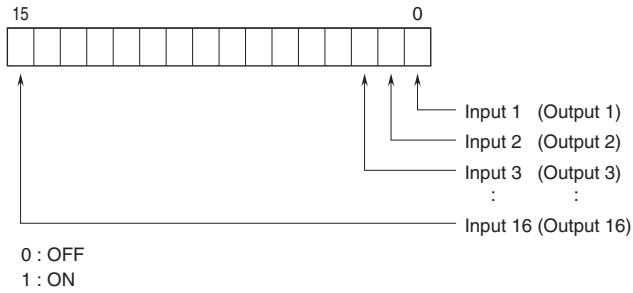

## ■PLC REDUNDANT SYSTEM (models: R3-NC3-x/W)

Bit 0 of RY(n+1) is assigned to designate control system or standby system. Set this bit from the host PLC to switch from the PLC master control system to the standby system, or vice versa. The R3 module output (slave station) is controlled according to the bit combinations as shown in the table below. No switching is required for the R3 input modules which continuously send out data to both 'main' and 'sub' network modules.

RY(n+1) 0 = 0 : PLC master control system  
 RY(n+1) 0 = 1 : PLC standby system

R3 MAIN (RY(n+1) 0)	R3 SUB (RY(n+1) 0)	CONTROL
0	0	Output from the 'main' network module.
0	1	Output from the 'main' network module.
1	0	Output from the 'sub' network module.
1	1	Hold the output

### •Operation

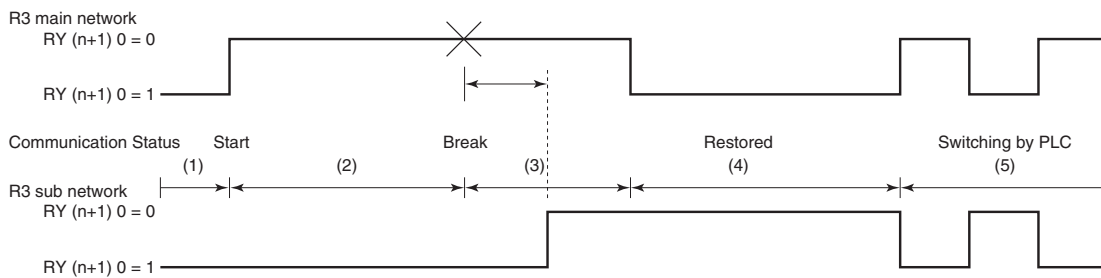

- 1) When the PLC master control/standby system bit is undefined due to no communication, the both host PLCs function as 'standby' system for each of R3 'main' and 'sub' network modules. All contact outputs are off, and analog output modules output -15%.
- 2) The master PLC communicates with the R3 main network module, while the standby PLC communicates with the R3 sub network module.
- 3) When a wire breakdown is detected at the R3 main network, the output signal is held for the preset time period (Timer is programmable with the PC Configurator Software, R3CON). After the time has been elapsed, the output is switched from the R3 main to R3 sub network. Be sure to set an appropriate output signal to the R3 sub network before the switching. The host PLC for the R3 main network is now functioning as standby system.
- 4) Once the PLC control is transferred to the standby system, it is necessary to set RY(n+1) 0 = 1 to the R3 main network in order to prevent R3 output control automatically switched to the main network when the R3 main network is restored. If it is set to RY(n+1) 0 = 0, the R3 output will be switched to the main network even when the PLC control is in the standby system.
- 5) When both R3 main and R3 sub network modules are in communication, the output can be switched without delay by setting RY(n+1) 0 values. Be sure to set an appropriate output signal to the network module before the control is switched to it.

## ■CONNECTION EXAMPLE for R3-NC3-x/W

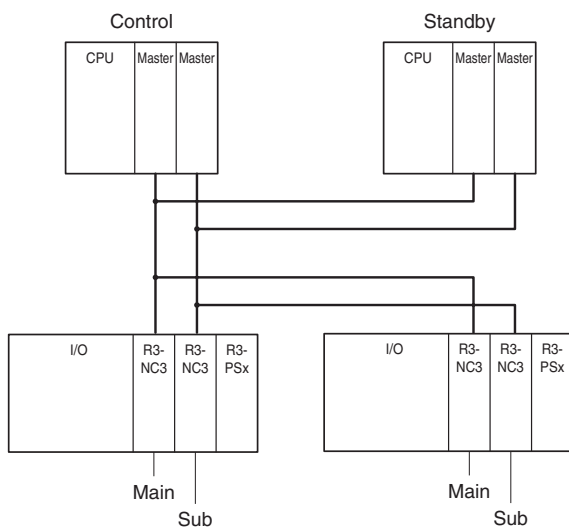

## EXTERNAL DIMENSIONS & TERMINAL ASSIGNMENTS unit: mm [inch]

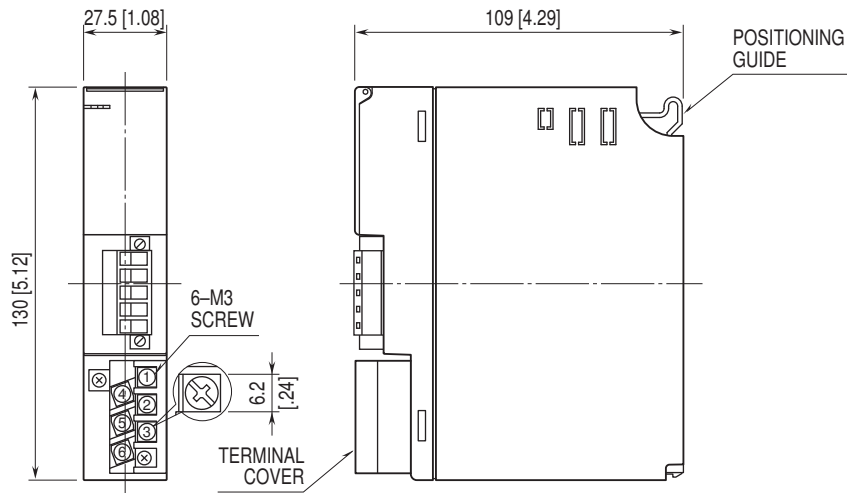

## SCHEMATIC CIRCUITRY & CONNECTION DIAGRAM

Note: In order to improve EMC performance, bond the FG terminal to ground.

Caution: FG terminal is NOT a protective conductor terminal.

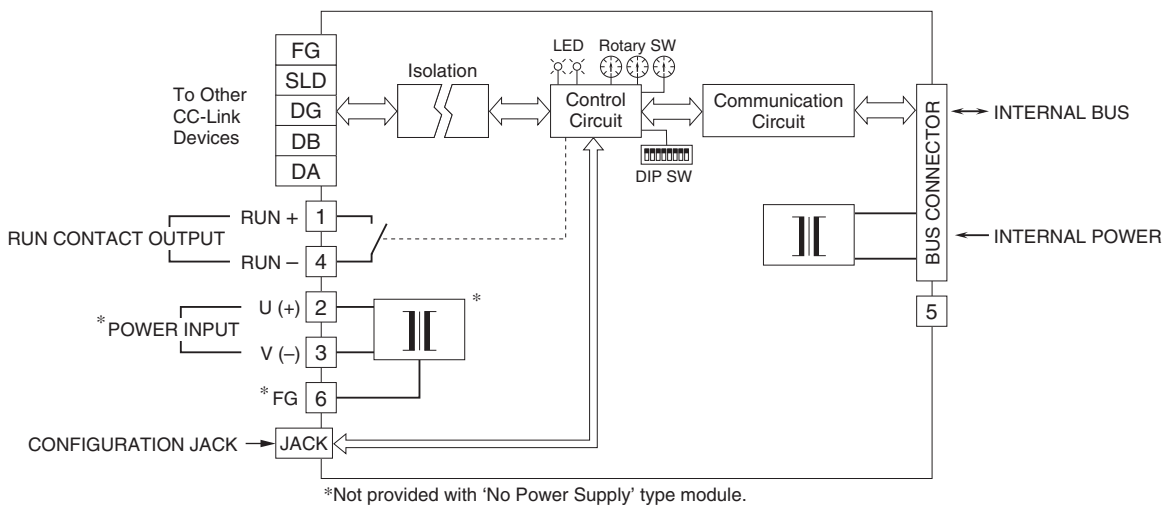

Specifications are subject to change without notice.