

## Remote I/O R3 Series

### INTERFACE I/O MODULE

(For SLMP Client)

#### Functions & Features

- Serves as a gateway for allowing data of SLMP-compatible devices to be handled by Network module that uses a different protocol.
- Reads/writes data from/to the SLMP server.
- Recognized as analog and/or discrete I/O modules by Network module according to the device configuration.

#### Typical Applications

- A gateway between SLMP and CC-Link.

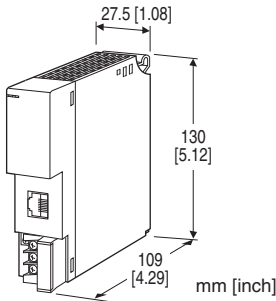

## MODEL: R3-GSLMP1S[1]

### ORDERING INFORMATION

- Code number: R3-GSLMP1S[1]  
Specify a code from below for [1].  
(e.g. R3-GSLMP1S/CE/Q)
- Specify the specification for option code /Q  
(e.g. /C01)

### COMMUNICATION MODE

S: Single

### [1] OPTIONS (multiple selections)

#### Standards & Approvals

blank: Without CE

/CE: CE marking

#### Other Options

blank: none

/Q: Option other than the above (specify the specification)

### SPECIFICATIONS OF OPTION: Q

**COATING (For the detail, refer to M-System's web site.)**

/C01: Silicone coating

/C02: Polyurethane coating

/C03: Rubber coating

### RELATED PRODUCTS

- PC configurator software (model: R3CON version 2.55 or later)

Downloadable at M-System's web site.

A dedicated cable is required to connect the module to the PC. Please refer to the internet software download site or the users manual for the PC configurator for applicable cable types.

### GENERAL SPECIFICATIONS

#### Connection

**Ethernet:** RJ-45 Modular Jack

**Internal bus:** Via the Installation Base (model: R3-BSx)

**Internal power:** Via the Installation Base (model: R3-BSx)

**RUN contact output:** M3 separable screw terminal  
(torque 0.5 N·m)

**Screw terminal:** Nickel-plated steel

**Isolation:** Ethernet to internal bus or internal power to RUN contact output

**RUN indicator:** Bi-color (green/red) LED

Green turns ON when SLMP communication is normal and fieldbus communication on the R3 Network module side is also normal; or

Red turns ON when receiving data.

(Indication selectable with DIP SW3-4.)

**ERR indicator:** Bi-color (green/red) LED

Green turns ON/blinks in communication errors (OFF with wire breakdown; Green blinks with setting errors); or Red turns ON when transmitting data.

(Indication selectable with DIP SW3-4.)

#### ■ RUN CONTACT OUTPUT

**RUN contact:** Turns on while the green RUN LED is ON (only when SLMP communication is normal and fieldbus communication on the R3 Network module side is also normal).

**Rated load:** 250 V AC @ 0.5 A (cos  $\phi$  = 1)

30 V DC @ 0.5 A (resistive load)

(Less than 50 V AC to conform with EU Directive)

**Maximum switching voltage:** 250 V AC or 30 V DC

**Maximum switching power:** 250 VA (AC) or 150 W (DC)

**Minimum load:** 1 V DC @ 1 mA

**Mechanical life:**  $2 \times 10^7$  cycles (300 cycles/min.)

When driving an inductive load, external contact protection and noise quenching are recommended.

### ETHERNET COMMUNICATION

**Communication Standard:** IEEE 802.3u

**Transmission:** 10BASE-T, 100BASE-TX

**Baud rate:** 10/100 Mbps (Auto Negotiation function)  
**Protocol:** SLMP  
**Data:** Binary  
**Max. number of socket connections:** 1  
**Max. number of communication entries:** 16  
**Max. number of I/O signals:** 128 points (total of analog and discrete signals)  
**Transmission media:** 10BASE-T (STP, Category 5), 100BASE-TX (STP, Category 5e)  
**Max. number of virtual I/O modules:** 16  
**Ethernet indicator LED:** LINK, DPLX, LINK10, LINK100, COL  
**Max. length of fieldbus segment:** 100 meters  
**IP address:** 192.168.0.1 (factory setting);  
Selectable with PC Configurator Software (model: R3CON)  
**Connectable devices:** MELSEC iQ-R series, MELSEC iQ-F series, MELSEC Q series

## INSTALLATION

**Operating temperature:** -10 to +55°C (14 to 131°F)  
**Operating humidity:** 30 to 90 %RH (non-condensing)  
**Atmosphere:** No corrosive gas or heavy dust  
**Mounting:** Installation Base (model: R3-BSx)  
**Weight:** 200 g (0.44 lb)

## PERFORMANCE

**Data Allocation (No. of Occupied Data Areas)**  
Virtual AI module: 16  
Virtual AO module: 16  
Virtual DI module: 1  
Virtual DO module: 1  
**Current consumption:** 100 mA  
**Insulation resistance:**  $\geq 100 \text{ M}\Omega$  with 500 V DC  
**Dielectric strength:** 1500 V AC @ 1 minute  
(Ethernet to internal bus or internal power to RUN contact output)  
2000 V AC @ 1 minute (power input to FG; isolated on the power supply module)

## STANDARDS & APPROVALS

**EU conformity:**  
EMC Directive  
EMI EN 61000-6-4  
EMS EN 61000-6-2  
RoHS Directive

**EXTERNAL VIEW**

■ FRONT VIEW

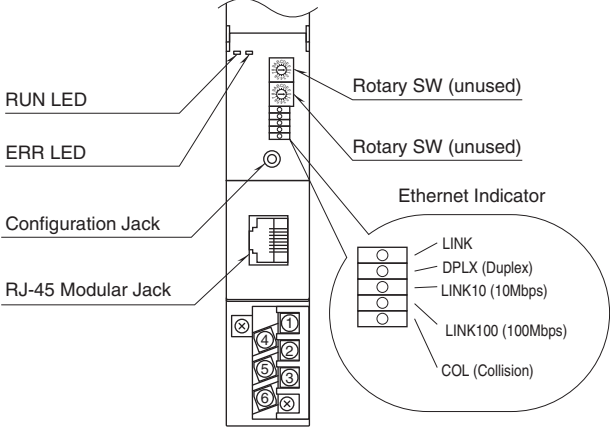

■ SIDE VIEW

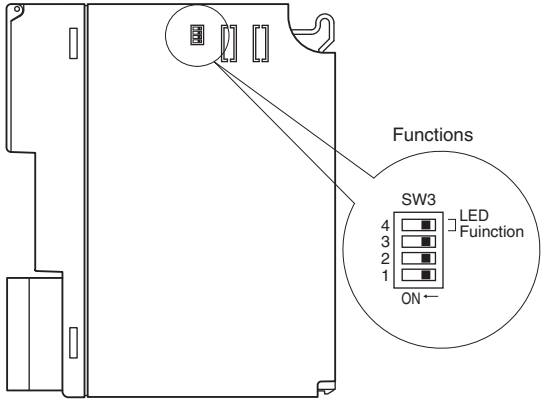

## TRANSMISSION DATA DESCRIPTIONS

R3-GSLMP1 reads/writes data from/in devices in SLMP-compatible CPU of Mitsubishi programmable controller MELSEC using SLMP. Devices from/in which data is read/written and addresses using SLMP are set on R3CON.

Mount the R3-GSLMP1 on the R3 base. Virtual input module sends the data read from SLMP server to the host PLC as an input data via R3 Interface module. Two signal types; AI (analog input) and DI (digital input) are available as virtual input module. Flow of the signal is as following.

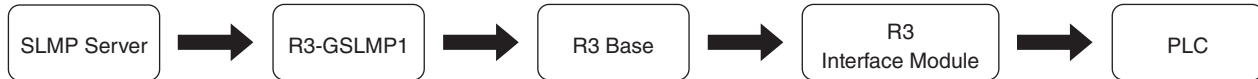

Virtual output module writes in the data written to the R3 Interface module from the host PLC, to the SLMP server. Two signal types; AO (analog output) and DO (digital output) are available as virtual output module. Flow of the signal is as following.

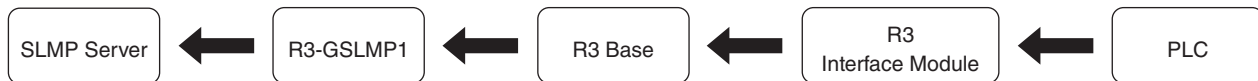

To read/write data from/in devices, 4 types of I/O are available. Refer to the following table.

. I/O TYPE:

	READ/WRITE	TRANSMITTING POINTS per MODULE	DATA ALLOCATION MODE	VIRTUAL I/O MODULE TYPE
AI (Analog input)	Read	16 points max.	16	Virtual input module
DI (Digital input)	Read	16 points max.	1	Virtual input module
AO (Analog output)	Write	16 points max.	16	Virtual output module
DO (Analog output)	Write	16 points max.	1	Virtual output module

The devices of the SLMP server are allocated to the virtual input module and the virtual output module of the R3-GSLMP1 by setting the R3-GSLMP1's I/O type, number of channels, device type and device address with R3CON.

- . Device Address: Begin address of read/write device (specify with hexadecimal or decimal)
- . Channel Number: 1 - 16 (Specify the number of data to read/write from begin address)

· Device: Commands to read from/write in the device (Refer to the following table for available device types)

## AVAILABLE DEVICE TYPES

AI / AO 32 bit	AI / AO 16 bit	DI / DO 32 bit	DI / DO 16 bit
SD: Special Register	SD: Special Register	SM: Special relay	SM: Special relay
D: Data Register	D: Data Register	X: Input	X: Input
W: Link Register	W: Link Register	Y: Output	Y: Output
TN: Timer, Current value	TN: Timer, Current value	M: Internal relay	M: Internal relay
STN: Retentive timer, Current value	STN: Retentive timer, Current value	L: Latch relay	L: Latch relay
CN: Counter, Current value	CN: Counter, Current value	F: Annunciator	F: Annunciator
SW, Link special Register	SW, Link special Register	V: Edge relay	V: Edge relay
Z: Index Register	Z: Index Register	B: Link relay	B: Link relay
R: File Register	R: File Register	----	S: STEP RELAY
ZR: File Register	ZR: File Register	TS: Timer, Contact	TS: Timer, Contact
RD: Module refresh Register	----	TC: Timer, Coil	TC: Timer, Coil
		LTS: Long timer, Contact	----
		LTC: Long timer, Coil	----
		STS: Retentive timer, Contact	STS: Retentive timer, Contact
		STC: Retentive timer, Coil	STC: Retentive timer, Coil
		LSTS: Long retentive timer, Contact	----
		LSTC: Long retentive timer, Coil	----
		CS: Counter, Contact	CS: Counter, Contact
		CC: Counter, Coil	CC: Counter, Coil
		LCS: Long counter, Contact	LCS: Long counter, Contact
		LCC: Long counter, Coil	LCC: Long counter, Coil
		SB: Link special relay	SB: Link special relay

Max. 16 points of analog input/output and max. 16 points of digital input/output can be allocated per a virtual module. Set the data allocation to 16 for the slot with the virtual analog input/output module, and set 1 for the slot with virtual digital input/output module by data allocation mode of the R3 Interface module.

Note: Numbers of transmittable data is limited by number of channel and virtual module. R3-GSLMP1 can transmitted max. 128 channels or 16 virtual modules. Even though the total number of channels is less than 128, if the total number of virtual modules is 16, number of channel cannot be increased.

Do not mount any modules in the slots which are occupied by virtual modules. If a real I/O module is mounted in the slot, an internal bus error occurs and the ERR LED turns on. Max. 16 real I/O modules and virtual modules are available. The R3 interface module can not read the data for more than 16 modules.

Details are explained in “■ Number of the modules and the address allocation” on the next page.

## ■ NUMBER of the MODULES and the ADDRESS ALLOCATION

### · DEVICE CONFIGURATION EXAMPLE 1

Device setting

I/O TYPE	CH. NO.	SLMP DEVICE	DEVICE ADDRESS
AI	2	SD	0x000
AI	4	D	0x000
AI	8	W	0x000
AI	3	TN	0x000
AI	10	SW	0x000

### · Virtual I/O modules configuration

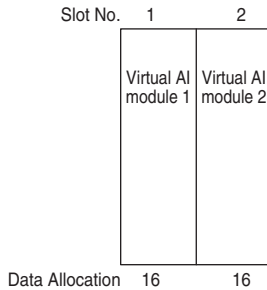

### · Data configuration

CH	ADDRESS	VIRTUAL AI MODULE 1 (SLOT NO.1)	ADDRESS	VIRTUAL AI MODULE 2 (SLOT NO.2)
1	n+0	SD 000	n+16	TN 002
2	n+1	SD 001	n+17	SW 000
3	n+2	D 000	n+18	SW 001
4	n+3	D 001	n+19	SW 002
5	n+4	D 002	n+20	SW 003
6	n+5	D 003	n+21	SW 004
7	n+6	W 000	n+22	SW 005
8	n+7	W 001	n+23	SW 006
9	n+8	W 002	n+24	SW 007
10	n+9	W 003	n+25	SW 008
11	n+10	W 004	n+26	SW 009
12	n+11	W 005	n+27	-
13	n+12	W 006	n+28	-
14	n+13	W 007	n+29	-
15	n+14	TN 000	n+30	-
16	n+15	TN 001	n+31	-

In this example, total numbers of channels are 20 and uses 2 virtual AI modules. Real I/O modules are mounted on Slots No. 1 and 2, however, the network module (R3-NC3) recognizes that each of Slots No. 1 to 3 is occupied. That is, R3-NC3 recognizes R3-SV4 mounted on Slot No.1 as it is and recognizes R3-GSLMP1 mounted on Slot No.2 as divided into two modules and occupying Slots No. 2 and 3.

R3-BS06

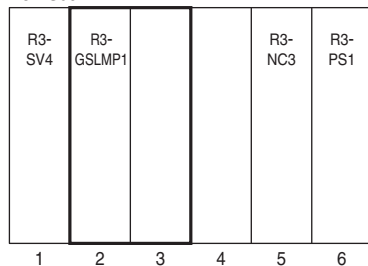

SLOT	REAL MODULE	VIRTUAL MODULE	DATA ALLOCATION	NO. OF WORDS
Slot No. 1	R3-SV4	-	4	4 words
Slot No. 2	R3-GSLMP1	R3-GSLMP1 (1/2)	16	16 words
Slot No. 3	No module	R3-GSLMP1 (2/2)	16	16 words
Slot No. 4	No module	-	-	-
Slot No. 5	R3-NC3	-	-	-
Slot No. 6	R3-PS1	-	-	-

· DEVICE CONFIGURATION EXAMPLE 2

Device setting

I/O TYPE	CH. NO.	SLMP DEVICE	DEVICE ADDRESS
DI	10	X	0x000
DI	2	M	0x000
DI	8	Y	0x000

· Virtual I/O modules configuration

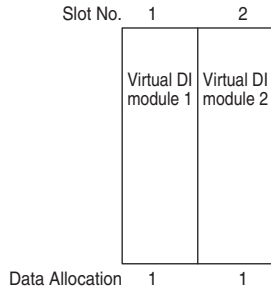

· Data configuration

CH	ADDRESS	F	E	D	C	B	A	9	8	7	6	5	4	3	2	1	0
Virtual DI module 1	n+0	Y3	Y2	Y1	Y0	M1	M0	X9	X8	X7	X6	X5	X4	X3	X2	X1	X0
Virtual DI module 2	n+1	-	-	-	-	-	-	-	-	-	-	-	-	Y7	Y6	Y5	Y4

In this example, total numbers of channels are 20 and uses 2 virtual DI modules. Real I/O modules are mounted on Slots No. 1 and 2, however, the network module (R3-NC3) recognizes that each of Slots No. 1 to 3 is occupied. That is, R3-NC3 recognizes R3-SV4 mounted on Slot No.1 as it is and recognizes R3-GSLMP1 mounted on Slot No.2 as divided into two modules and occupying Slots No. 2 and 3.

R3-BS06

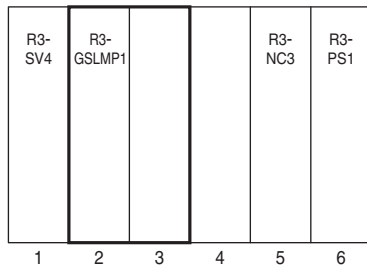

SLOT	REAL MODULE	VIRTUAL MODULE	DATA ALLOCATION	NO. OF WORDS
Slot No. 1	R3-SV4	-	4	4 words
Slot No. 2	R3-GSLMP1	R3-GSLMP1 (1/2)	1	1 words
Slot No. 3	No module	R3-GSLMP1 (2/2)	1	1 words
Slot No. 4	No module	-		-
Slot No. 5	R3-NC3	-		-
Slot No. 6	R3-PS1	-		-

## · DEVICE CONFIGURATION EXAMPLE 3

### Device setting

I/O TYPE	CH. NO.	SLMP DEVICE	DEVICE ADDRESS
AI	20	D	0x000
DI	20	X	0x000
DI	20	M	0x000

### · Virtual I/O modules configuration

Slot No.	1	2	3	4	5
	Virtual AI module 1	Virtual AI module 2	Virtual DI module 1	Virtual DI module 2	Virtual DI module 3

Data Allocation 16 16 1 1 1

### · Data configuration

Ch	ADDRESS	VIRTUAL AI MODULE 1 (Slot 1)	ADDRESS	VIRTUAL AI MODULE 2 (Slot 2)	ADDRESS	VIRTUAL DI MODULE 1 (Slot 3)	ADDRESS	VIRTUAL DI MODULE 2 (Slot 4)	ADDRESS	VIRTUAL DI MODULE 3 (Slot 5)
1	n+0	D 000	n+16	D 016	n+32	X0 – 15	n+33	X16 – 19, M0 – 11	n+34	M12 – 19
2	n+1	D 001	n+17	D 017						
3	n+2	D 002	n+18	D 018						
4	n+3	D 003	n+19	D 019						
5	n+4	D 004	n+20	–						
6	n+5	D 005	n+21	–						
7	n+6	D 006	n+22	–						
8	n+7	D 007	n+23	–						
9	n+8	D 008	n+24	–						
10	n+9	D 009	n+25	–						
11	n+10	D 010	n+26	–						
12	n+11	D 011	n+27	–						
13	n+12	D 012	n+28	–						
14	n+13	D 013	n+29	–						
15	n+14	D 014	n+30	–						
16	n+15	D 015	n+31	–						

	ADDRESS	F	E	D	C	B	A	9	8	7	6	5	4	3	2	1	0
Virtual DI module 1	n+32	X15	X14	X13	X12	X11	X10	X9	X8	X7	X6	X5	X4	X3	X2	X1	X0
Virtual DI module 2	n+33	M11	M10	M9	M8	M7	M6	M5	M4	M3	M2	M1	M0	X19	X18	X17	X16
Virtual DI module 3	n+34	–	–	–	–	–	–	–	–	M19	M18	M17	M16	M15	M14	M13	M12

In this example, total numbers of AI channels are 20, total numbers of DI channels are 40 and uses total 5 virtual modules (2 virtual AI modules and 3 virtual DI modules). Real I/O modules are mounted on Slots No. 1 and 2, however, the network module (R3-NC3) recognizes that each of Slots No. 1 to 6 is occupied. That is, R3-NC3 recognizes R3-SV4 mounted on Slot No.1 as it is and recognizes R3-GSLMP1 mounted on Slot No.2 as divided into 5 modules and occupying Slots No. 2 and 6.

### R3-BS06

1	2	3	4	5	6	7	8
R3-SV4	R3-GSLMP1					R3-NC3	R3-PS1

SLOT	REAL MODULE	VIRTUAL MODULE	DATA ALLOCATION	NO. OF WORDS
Slot No. 1	R3-SV4	–	4	4 words
Slot No. 2	R3-GSLMP1	R3-GSLMP1 (1/5)	16	16 words
Slot No. 3	No module	R3-GSLMP1 (2/5)	16	16 words
Slot No. 4	No module	R3-GSLMP1 (3/5)	1	1 words
Slot No. 5	No module	R3-GSLMP1 (4/5)	1	1 words
Slot No. 6	No module	R3-GSLMP1 (5/5)	1	1 words
Slot No. 7	R3-NC3	–	–	–
Slot No. 8	R3-PS1	–	–	–



## I/O DATA DESCRIPTIONS

### ■ VIRTUAL ANALOG I/O DATA



16-bit binary data

### ■ VIRTUAL DIGITAL I/O DATA

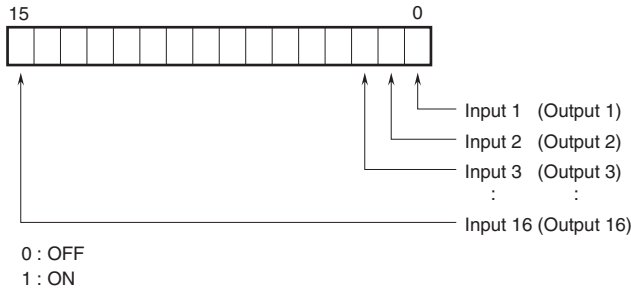

### ■ ANALOG/DIGITAL INPUT DATA

- When the R3-GSLMP1 cannot communicate with SLMP server at the start up, AI or DI data turn to 0.
- When the communication between the R3-GSLMP1 and the SLMP server is lost due to an error, the last process values are held until the communication is re-established.

### ■ ANALOG/DIGITAL OUTPUT DATA

- When the R3-GSLMP1 does not starting communication with SLMP server at the start up, write AI or DI data of 0 to the SLMP server.
- When the communication between the R3 Interface module and the host PLC is lost, the last process values are write in the SLMP server. The values are held until the communication is re-established.

## EXTERNAL DIMENSIONS & TERMINAL ASSIGNMENTS unit: mm [inch]

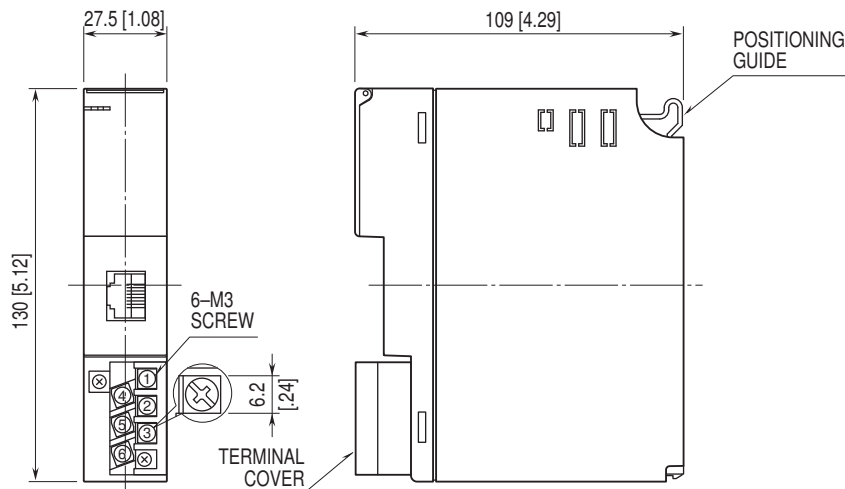

## SCHEMATIC CIRCUITRY & CONNECTION DIAGRAM

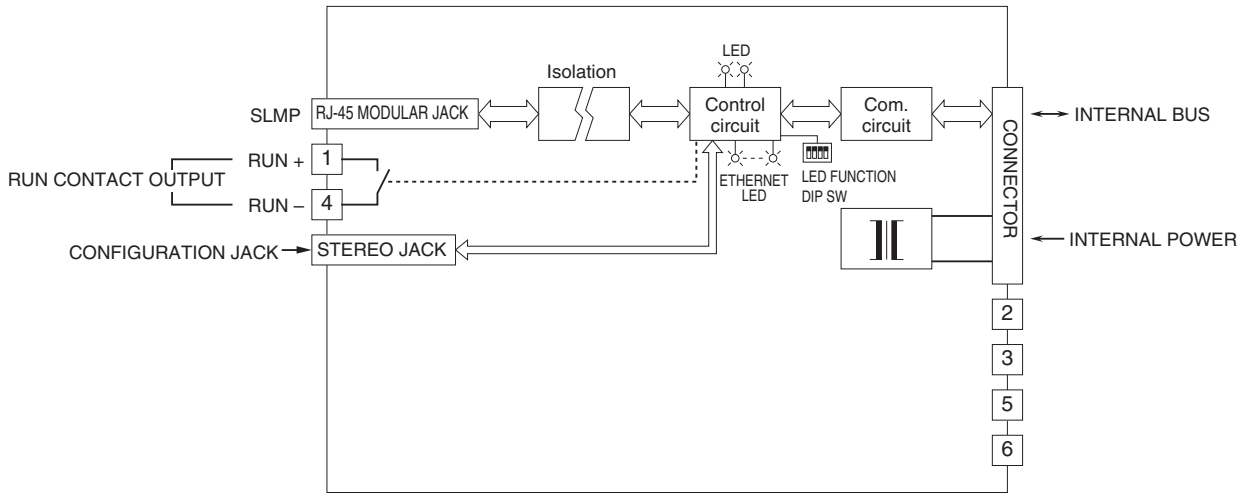

## SYSTEM CONFIGURATION EXAMPLES

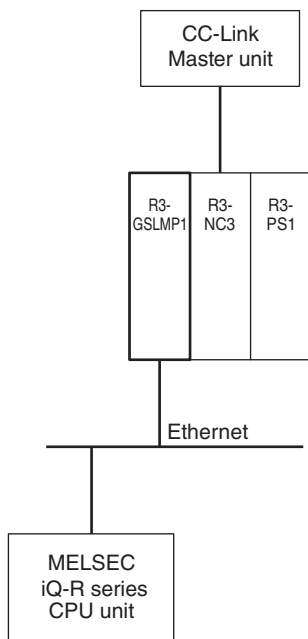

Specifications are subject to change without notice.