

## Remote I/O R3 Series

### FL-net INTERFACE MODULE

(OPCN-2, Ver.2.0 supported)

#### Functions & Features

- Usable as a gateway between different protocols combined with R3 interface modules
- FL-net (OPCN-2), Ethernet based, controller level network, compatible remote I/O
- 10 Mbps/100 Mbps cyclic transmission for the maximum of 4k bits + 256 words (1 word = 16 bits) allows data shared among the devices connected to the bus
- FL-net bus extended to max. 500 meters, up to 2.5 kilometers with a repeater
- No need of ladder programming

#### Typical Applications

- A gateway between FL-net and Modbus

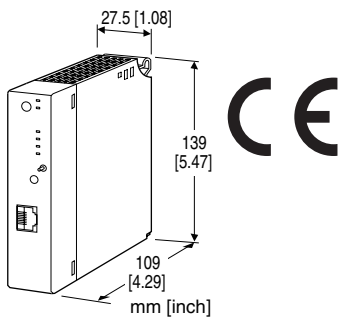

## MODEL: R3-GFL1S[1]

### ORDERING INFORMATION

- Code number: R3-GFL1S[1]

Specify a code from below for [1].

- (e.g. R3-GFL1S/CE/Q)
- Specify the specification for option code /Q (e.g. /C01)

### COMMUNICATION MODE

S: Single

### [1] OPTIONS (multiple selections)

#### Standards & Approvals

blank: Without CE

/CE: CE marking

#### Other Options

blank: none

/Q: Option other than the above (specify the specification)

### SPECIFICATIONS OF OPTION: Q

**COATING (For the detail, refer to M-System's web site.)**

/C01: Silicone coating

/C02: Polyurethane coating

/C03: Rubber coating

### FUNCTIONS & FEATURES

- R3-GFL1 enables the other interface module to access field signals as virtual I/O data via FL-net. No ladder programming is required to assign these I/O signals.
- Any PC or PLC compatible with FL-net, up to 254 nodes, can retrieve the updated data by accessing the common memory without interfering with the communication traffic.
- Analog and discrete input signals cyclically transmitted from other devices can be output as virtual analog signal. The FL-net Configuration Builder software (model: R3-NFLBLD) is used to assign these virtual analog signals on the common memory in the bit or word units.
- Request/Response type message communication, accessing I/O data only when necessary, is also possible.

#### CAUTION !

- FL-net standard requires a dedicated Ethernet bus for the FL-net compatible devices. Connecting the R3-GFL1 to a general-purpose LAN, or connecting a general-purpose TCP/IP device to FL-net is Not allowed.
- FL-net uses UDP/IP protocol for transmission. ISDN, ADSL or similar types of LAN are Not to be used.

### CAUTION

- When selecting network modules, note that this unit is not designed to be used with network modules of certain types or versions.
- This unit CANNOT be used with R3-NC2, R3-NEIP1, R3-NFx, and R3-NLx.
- This unit CAN be used with:
  - R3-NM3 and R3-NML3 of firmware version V1.00 or higher;
  - R3-NC1, R3-NC3, R3-NDx, R3-NE1, R3-NFL1, R3-NM1, R3-NM4, and R3-NP1 of firmware version V2.00 or higher;
  - and
  - other models of any firmware versions.

### RELATED PRODUCTS

- FL-net configuration builder (Model: R3-NFLBLD) Downloadable at M-System's web site.

### GENERAL SPECIFICATIONS

#### Connection

**FL-net:** RJ-45 connector

**Internal bus:** Via the Installation Base (model: R3-BSx)

**Internal power:** Via the Installation Base (model: R3-BSx)

**RUN contact output:** Euro type connector terminal  
(applicable wire size: 0.2 to 2.5 mm<sup>2</sup>, stripped length 7 mm)

**RUN/CFG selector:** Toggle switch; RUN or Configuration

**Isolation:** Ethernet to internal bus or internal power to RUN contact output

#### Indicator LEDs

**RUN:** Green LED turns on when the CPU, internal bus and field bus on the other interface module are in normal conditions.

**ERR:** Red LED turns on in an abnormality of the system.

**LNK:** Red LED turns on while the R3-GFL1 is participating FL-net (normal communication)

**HER:** Red LED turns on in an abnormality of I/O data.

**PER:** Red LED blinks on with the parameter setting error.

**CFG:** Red LED blinks in high speed at the startup; blinks in low speed while the builder software is used.

**TX:** Green LED turns on while transmitting.

**RX:** Amber LED turns on while receiving.

**Module allocation:** Set with the side DIP switch.

#### ■ RUN CONTACT OUTPUT

**RUN contact:** Relay turns on when the CPU, the internal bus function and the field bus on the other interface module are in normal conditions.

**Rated load:** 250 V AC @0.5A (cos  $\phi$  = 1)

30 V DC @ 0.5 A (resistive load)

(< 50 V AC, < 75 V DC for EU conformity)

**Maximum switching voltage:** 250 V AC or 220 V DC

**Maximum switching power:** 62.5 VA or 60 W

**Minimum load:** 10 mV DC @ 1 mA

**Mechanical life:** 5 × 10<sup>7</sup> cycles (rate 300/min.)

When driving an inductive load, external contact protection and noise quenching are recommended.

## FL-net SPECIFICATIONS

**FL-net:** Ver.2.0 supported

**Physical layer standard:** IEEE 802.3u

**Data link layer:** 10BASE-T / 100BASE-TX

**Baud rate:** 10 / 100 Mbps, Auto Negotiation

**Protocol:** FL-net (OPCN-2) (UDP/IP)

**Transmission media:** 10BASE-T (STP cable, category 5)

100BASE-TX (STP cable, category 5e)

**Max. segment length:** 100 meters

**Max. number of nodes:** 254

**IP address:** FL-net Configuration Builder is used to set up the IP address and the network address.

#### Factory setting:

192.168.250.1 (IP address)

255.255.255.0 (network address)

**Max. cyclic data size:**

8 k bits (area 1) + 8 k words (area 2) / system

4 k bits (area 1) + 256 words (area 2) / node

**Max. message data size:** 1024 bytes (per transmission cycle)

**Performance** (2k bits + 2k words / node, 32 nodes in total)

**Token cycle time:** 50 milliseconds (1.56 milliseconds/ node in average)

**Message transmission time:** 500 milliseconds (1 : 1 unidirectional message)

## INSTALLATION

**Current consumption:** 150 mA

**Operating temperature:** -10 to +55°C (14 to 131°F)

**Operating humidity:** 30 to 90 %RH (non-condensing)

**Atmosphere:** No corrosive gas or heavy dust

**Mounting:** Installation Base (model: R3-BSx)

**Weight:** 200 g (0.44 lb)

## PERFORMANCE

**Data allocation:** 16 × n (Module allocation: 1 to 8)

**Insulation resistance:** ≥ 100 MΩ with 500 V DC

**Dielectric strength:** 1500 V AC @ 1 minute

(Ethernet to internal bus or internal power to RUN contact output)

2000 V AC @ 1 minute (power input to FG; isolated on the power supply module)

## STANDARDS & APPROVALS

**EU conformity:**

EMC Directive

EMI EN 61000-6-4

EMS EN 61000-6-2

RoHS Directive

## FL-net DESCRIPTIONS

### ■ CYCLIC TRANSMISSION

- Transmitting virtual I/O value, this module's information and node error of signal source.
- Supplying common memory word data transmitted from another devices as virtual output.
- If the node that this module is accessing has been removed from the common memory, the operations "Hold output" and "Clear Output" are selectable.

### ■ MESSAGE TRANSMISSION

The module supports the FL-net defined functions listed in the following table. Only the server function is supported. Server function allows the module to build a response frame to a request message.

Client function allows the module to transmit a request message and to receive its response frame.

MESSAGE TYPE	SERVER	CLIENT
Byte block read	No	No
Byte block write	No	No
Word block read	Yes	No
Word block write	Yes	No
Network parameter read	Yes	No
Network parameter write	No	No
Stop command	Yes	No
Start command	Yes	No
Profile read	Yes	No
Transparent mode	No	No
Log data read	Yes	No
Log data clear	Yes	No
Message echo back	Yes	No

## PC REQUIREMENTS (provided by the user)

The following PC environment is required to run the R3-NFLBLD program.

**Operating system:** Windows 7 (32-bit/64-bit) or Windows 10 (32-bit/64-bit)

**Screen area:** 1024 by 768 pixels

**LAN card:** Required to connect to Ethernet

## EXTERNAL VIEW

### FRONT VIEW

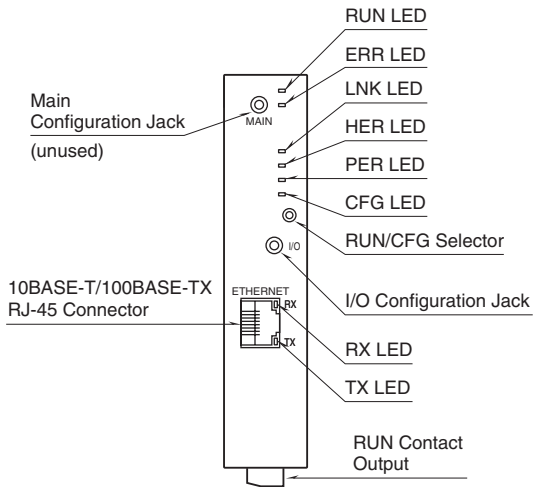

### SIDE VIEW

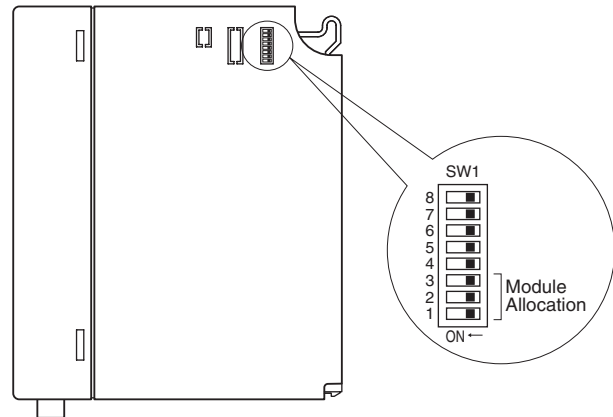

## TRANSMISSION DATA DESCRIPTIONS

Use the DIP SW located at the side of the module to specify module allocation.

1 module is equivalent to 1 I/O module with 16 words analog input and 16 words analog output. Max. 8 modules (128 words input, 128 words output) transmission is available. R3-GFL1 seems as if max. 8 I/O modules are mounted to 8 slots via FL-net. The input of the module is processed as follows.

[FL-net Communication] --> [R3-GFL1 Module] --> [R3 Base] --> [R3 Communication Module]

The data set with output tab of R3-NFLBLD to input is transmitted to R3 communication module. Output is reversed. The data set with transmitting area 1 and transmitting area 2 is transmitted to FL-net.

Note: Do not mount any modules in the slots which are occupied by virtual modules. If a real I/O module is mounted in the slot, an internal bus error occurs. Max. 16 real I/O modules and virtual modules are available. The interface module can not read the data for more than 16 modules.

### WHEN R3-GFL1 IS MOUNTED ON SLOT NO. 2 (4 modules)

Real I/O modules are mounted on Slots No. 1 and 2, however, the network module (R3-NE1) recognizes that each of Slots No. 1 to 5 is occupied. That is, R3-NE1 recognizes R3-SV4 mounted on Slot No.1 as it is and recognizes R3-GFL1 mounted on Slot No.2 as divided into four modules and occupying Slots No. 2 to 5.

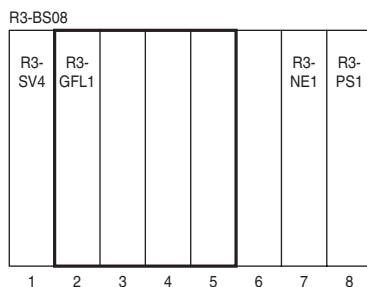

SLOT	REAL MODULE	VERTUAL MODULE	NO. OF WORDS
Slot No.1	R3-SV4	R3-SV4	4 Words
Slot No.2	R3-GFL1	R3-GFL1 (1/4)	16 Words
Slot No.3	No module	R3-GFL1 (2/4)	16 Words
Slot No.4	No module	R3-GFL1 (3/4)	16 Words
Slot No.5	No module	R3-GFL1 (4/4)	16 Words
Slot No.6	No module	No module	----
Slot No.7	R3-NE1	R3-NE1	----
Slot No.8	R3-PS1	R3-PS1	----

## I/O DATA DESCRIPTIONS

### ■ MODULE STATUS, SOURCE NODE ERROR

Shows each module's availability and error status.

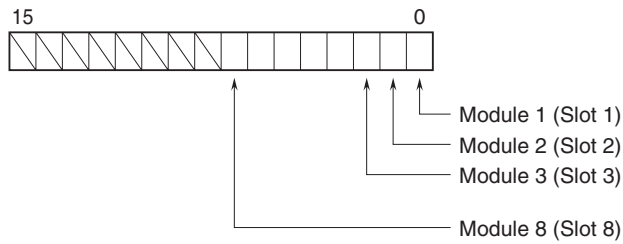

### ■ ANALOG DATA

16-bit binary data.

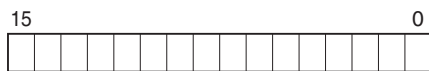

## EXTERNAL DIMENSIONS unit: mm [inch]

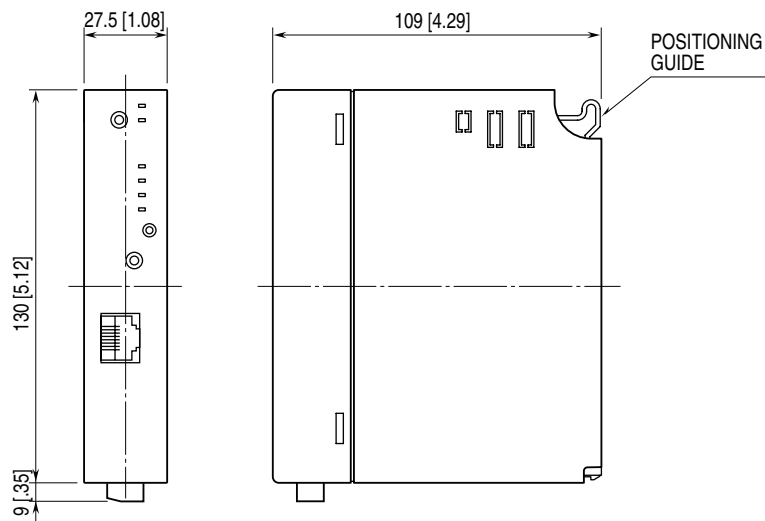

## SCHEMATIC CIRCUITRY & CONNECTION DIAGRAM

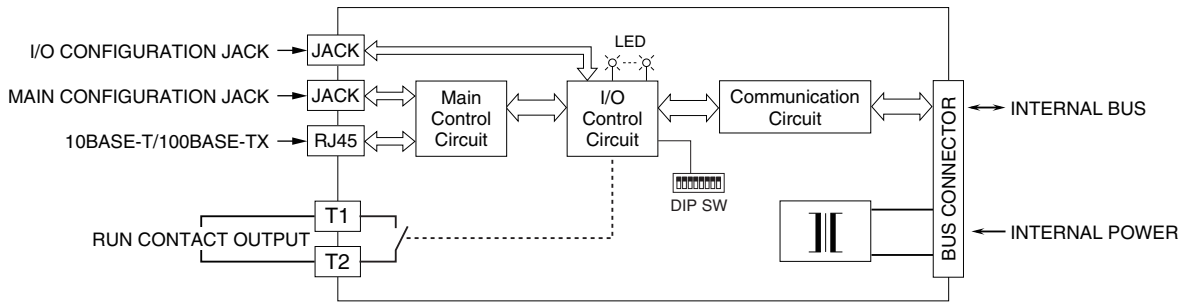

## SYSTEM CONFIGURATION EXAMPLES

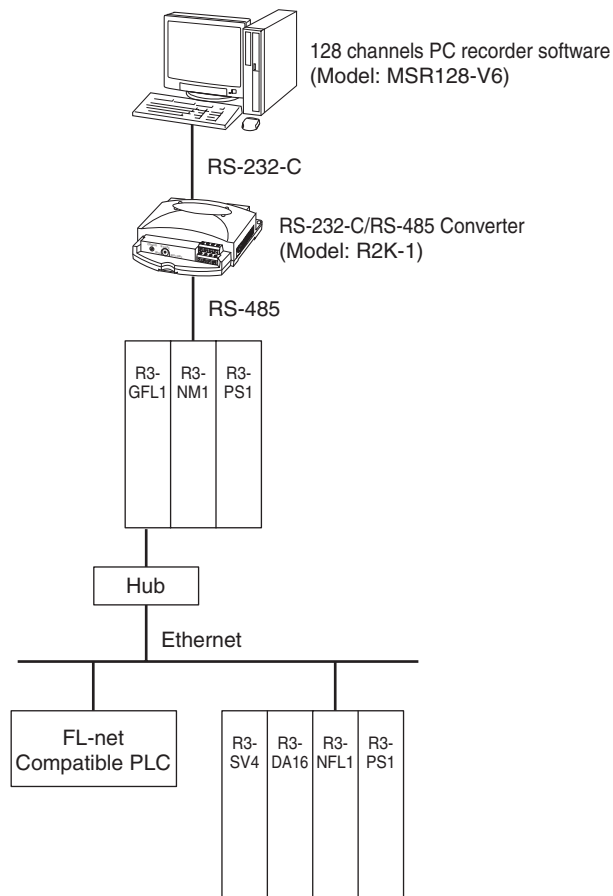

Specifications are subject to change without notice.