

Remote I/O R3 Series

/C03: Rubber coating

DISCRETE INPUT OUTPUT MODULE

(Di 8 points, Do 8 points)

Typical Applications

- Controls start/stop of field devices with ON/OFF control output
- Simplifies signal hold circuit of field devices
- Utilizing One-Shot Output reduces the load of PLC side.

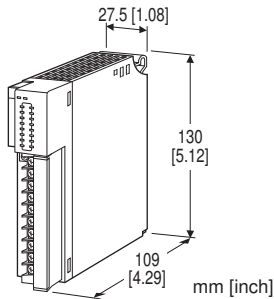

MODEL: R3-DAC16[1][2]

ORDERING INFORMATION

- Code number: R3-DAC16[1][2]
- Specify a code from below for each of [1] and [2].
(e.g. R3-DAC16W/CE/Q)
- Specify the specification for option code /Q
(e.g. /C01)

NO. OF CHANNELS

16: 8 points input, 8 points output

[1] COMMUNICATION MODE

S: Single

W: Dual

[2] OPTIONS (multiple selections)

Standards & Approvals

blank: Without CE

/CE: CE marking

Other Options

blank: none

/Q: Option other than the above (specify the specification)

SPECIFICATIONS OF OPTION: Q

COATING (For the detail, refer to M-System's web site.)

/C01: Silicone coating

/C02: Polyurethane coating

CAUTION

- This unit is not designed to be used with the following types of interface modules (models: R3-NC2, R3-NEIP1, R3-NFx, R3-NLx).
- Output completion status data is compatible with interface modules (models: R3-NC1, R3-NC3, R3-NDx, R3-NE1, R3-NFL1, R3-NM1, R3-NM4, R3-NP1) of firmware version V2.00 or higher, and interface modules (models: R3-NM3, R3-NML3) of firmware version V1.00 or higher.

GENERAL SPECIFICATIONS

Connection

Internal bus: Via the Installation Base (model: R3-BSx)

Input, Output: M3 separable screw terminal
(torque 0.5 N·m)

Internal power: Via the Installation Base (model: R3-BSx)

Screw terminal: Nickel-plated steel

Isolation: Input to output to internal bus or internal power

Output mode setting: One-Shot Output Mode, ON/OFF Control Output Mode, Continuance Output Mode selectable with DIP switch

Data length Setting: 8bit, 4bit selectable with DIP switch
(For ON/OFF Control Output Mode only)

One-shot ON time setting: 0.1 to 25.6 sec. selectable with DIP switch

ON/OFF control output setting: Swappable its pair with DIP switch.

Output hold setting: Setting for communication error with side DIP SW

RUN indicator: Bi-color (red/green) LED;
Red when the bus A operates normally;
Green when the bus B operates normally;
Amber when both buses operate normally.

ERR indicator: Bi-color (red/ green) LED;
Green in normal operating conditions
Red with the abnormal configuration

Status indicator: Red LED;

1 to 8: Input status, turns on with input ON.

9 to 16: Output status, turns on with output ON.

Di read rate setting: 1 / 5 / 10 / 20 / 50 / 70 / 100 / 200 msec. selectable with DIP SW

INPUT SPECIFICATIONS

Number of input: 8 points

Isolation: Optical isolator

Input resistance: Approx. 4.4 kΩ

Common: Positive or negative (NPN/PNP) common per 8 points (2 terminals)

Rated input voltage: 24 V DC +10/-15 % (ripple 5 %p-p)

max.)

ON voltage/current: $\geq 11\text{ V}$, $\geq 2.5\text{ mA}$

OFF voltage/current: $\leq 6\text{ V}$, $\leq 1.3\text{ mA}$

OUTPUT SPECIFICATIONS

Number of output: 8 points

Common: All 8 points (2 terminals)

Common current: Max. 2 A (total of 2 terminals)

Rated load:

250 V AC @ 0.5 A ($\cos \phi = 1$)

30 V DC @ 0.5 A (resistive load)

(Less than 50 V AC to conform with EU Directive)

Maximum switching voltage: 250 V AC or 30 V DC

Maximum switching power: 250 VA or 30 W

Minimum load: 1 V DC @ 1 mA

Mechanical life: 2×10^7 cycles (300 cycles/min.)

When driving an inductive load, external contact protection and noise quenching recommended.

INSTALLATION

Operating temperature: -10 to $+55^\circ\text{C}$ (14 to 131°F)

Operating humidity: 30 to 90 %RH (non-condensing)

Atmosphere: No corrosive gas or heavy dust

Mounting: Installation Base (model: R3-BSx)

Weight: 200 g (0.44 lb)

PERFORMANCE

Output ON time accuracy: $\pm 10\%$ max. for 1 sec. or less setting; ± 0.1 sec. max. for 1 sec. or more setting

Data allocation: 1

Current consumption: 130 mA

Insulation resistance: $\geq 100\text{ M}\Omega$ with 500 V DC

Dielectric strength: 1500 V AC @ 1 minute (input to output to internal bus or internal power)

2000 V AC @ 1 minute (power input to FG; isolated on the power supply module)

STANDARDS & APPROVALS

EU conformity:

EMC Directive

EMI EN 61000-6-4

EMS EN 61000-6-2

RoHS Directive

FUNCTIONS

■ **OUTPUT HOLD or OUTPUT OFF**

In normal conditions, the module outputs the signal from the preferred bus A.

When an error is detected, the output is switched to the data from the bus B.

• **Output Hold**

If both are in error, the module holds the signal and stands by until one of the communications recovers.

• **Output OFF**

If both are in error, the module outputs OFF signals and stands by until one of the communications recovers.

At the startup, it outputs OFF until the communication is established and normal data is received.

EXTERNAL VIEW

FRONT VIEW

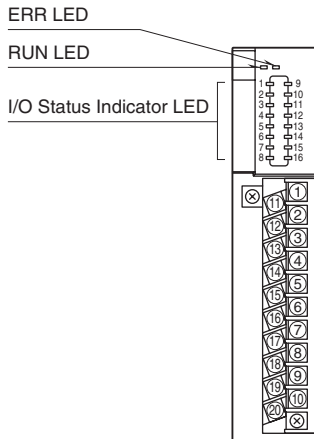

SIDE VIEW

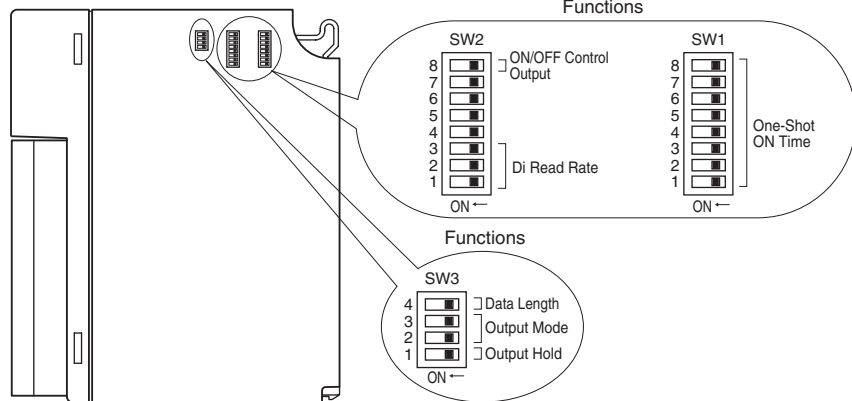

I/O DATA DESCRIPTIONS

ONE-SHOT OUTPUT MODE

8-bit output data (Do 1 through 8) and output (Ch1 through 8) are assigned 1:1.

Do	WRITE	ONE-SHOT OUTPUT/RESET	Di	OUTPUT COMPLETION STATUS
Do 1	1	Ch1 Output	Di 9	Ch1 Output Completion Status
	0	Ch1 Output Completion Reset		
Do 2	1	Ch2 Output	Di 10	Ch2 Output Completion Status
	0	Ch2 Output Completion Reset		
Do 3	1	Ch3 Output	Di 11	Ch3 Output Completion Status
	0	Ch3 Output Completion Reset		
Do 4	1	Ch4 Output	Di 12	Ch4 Output Completion Status
	0	Ch4 Output Completion Reset		
Do 5	1	Ch5 Output	Di 13	Ch5 Output Completion Status
	0	Ch5 Output Completion Reset		
Do 6	1	Ch6 Output	Di 14	Ch6 Output Completion Status
	0	Ch6 Output Completion Reset		
Do 7	1	Ch7 Output	Di 15	Ch7 Output Completion Status
	0	Ch7 Output Completion Reset		
Do 8	1	Ch8 Output	Di 16	Ch8 Output Completion Status
	0	Ch8 Output Completion Reset		

■ ON/OFF CONTROL OUTPUT MODE

• Data Length: 8 bits

Do 1 through 8 are assigned to Ch1 through 8.

Do	WRITE	ONE-SHOT OUTPUT/RESET	Di	OUTPUT COMPLETION STATUS
Do 1 Do 2	0 0	Not Operating		
	1 0	Ch1 Output	Di 9	Ch1 Output Completion Status
	0 1	Ch2 Output	Di 10	Ch2 Output Completion Status
	1 1	Output Data Reset		
Do 3 Do 4	0 0	Not Operating		
	1 0	Ch3 Output	Di 11	Ch3 Output Completion Status
	0 1	Ch4 Output	Di 12	Ch4 Output Completion Status
	1 1	Output Data Reset		
Do 5 Do 6	0 0	Not Operating		
	1 0	Ch5 Output	Di 13	Ch5 Output Completion Status
	0 1	Ch6 Output	Di 14	Ch6 Output Completion Status
	1 1	Output Data Reset		
Do 7 Do 8	0 0	Not Operating		
	1 0	Ch7 Output	Di 15	Ch7 Output Completion Status
	0 1	Ch8 Output	Di 16	Ch8 Output Completion Status
	1 1	Output Data Reset		

The above table shows the case of Not Swapped (SW2-8: OFF). ON/OFF control output is swapped with its pair when SW2-8 is ON. The following is an example of Do 1 and Do 2.

Do	WRITE	ONE-SHOT OUTPUT/RESET	Di	OUTPUT COMPLETION STATUS
Do 1 Do 2	0 0	Not Operating		
	1 0	Ch2 Output	Di 10	Ch2 Output Completion Status
	0 1	Ch1 Output	Di 9	Ch1 Output Completion Status
	1 1	Output Data Reset		

• Data Length: 4 bits

Do 1 through 4 are assigned to Ch1 through 8 as 1:2.

Do	WRITE	ONE-SHOT OUTPUT/RESET	Di	OUTPUT COMPLETION STATUS
Do 1	0	Ch1 Output	Di 9	Ch1 Output Completion Status
	1	Ch2 Output	Di 10	Ch2 Output Completion Status
Do 2	0	Ch3 Output	Di 11	Ch3 Output Completion Status
	1	Ch4 Output	Di 12	Ch4 Output Completion Status
Do 3	0	Ch5 Output	Di 13	Ch5 Output Completion Status
	1	Ch6 Output	Di 14	Ch6 Output Completion Status
Do 4	0	Ch7 Output	Di 15	Ch7 Output Completion Status
	1	Ch8 Output	Di 16	Ch8 Output Completion Status

The above table shows the case of Not Swapped (SW2-8: OFF). ON/OFF control output is swapped with its pair when SW2-8 is ON. The following is an example of Do 1.

Do	WRITE	ONE-SHOT OUTPUT/RESET	Di	OUTPUT COMPLETION STATUS
Do 1	0	Ch2 Output	Di 10	Ch2 Output Completion Status
	1	Ch1 Output	Di 9	Ch1 Output Completion Status

■ CONTINUOUS OUTPUT MODE

Do 1 through 8 are assigned to and Ch1 through 8. When data Do is “1” output is ON (energized) and when it is “0” output is OFF (de-energized). The operation is equivalent to 16 points discrete output module (model: R3-DC16). Output completion status Di is related to Do.

Do	CONTINUOUS OUTPUT	Di	OUTPUT COMPLETION STATUS
Do 1	Ch1 Output	Di 9	Ch1 Output Completion Status
Do 2	Ch2 Output	Di 10	Ch2 Output Completion Status
Do 3	Ch3 Output	Di 11	Ch3 Output Completion Status
Do 4	Ch4 Output	Di 12	Ch4 Output Completion Status
Do 5	Ch5 Output	Di 13	Ch5 Output Completion Status
Do 6	Ch6 Output	Di 14	Ch6 Output Completion Status
Do 7	Ch7 Output	Di 15	Ch7 Output Completion Status
Do 8	Ch8 Output	Di 16	Ch8 Output Completion Status

DATA ASSIGNMENT

■ Do

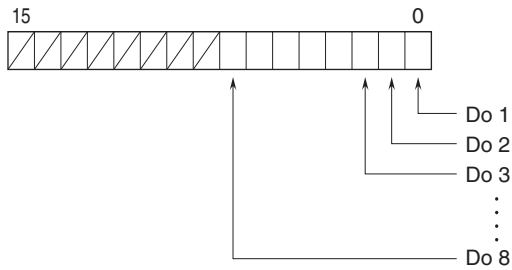

Note 1: For 4-bit length ON/OFF control mode, Do 5 through Do 8 are unavailable.

Note 2: For the combination with Modbus communication module (model: R3-NE1, R3-NM1 and such), use the addresses of Coil (0X) for Modbus I/O assignment.

■ Di

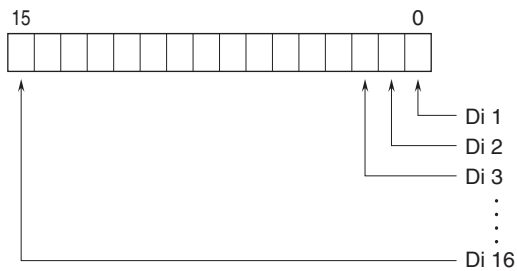

Note 1: Di 9 – 16 data is not practical discrete input data. It is “output completion status” internal data.

Note 2: For the combination with Modbus communication module (model: R3-NE1, R3-NM1 and such), use the addresses of Input (1X) for Modbus I/O assignment.

EXTERNAL DIMENSIONS & TERMINAL ASSIGNMENTS unit: mm [inch]

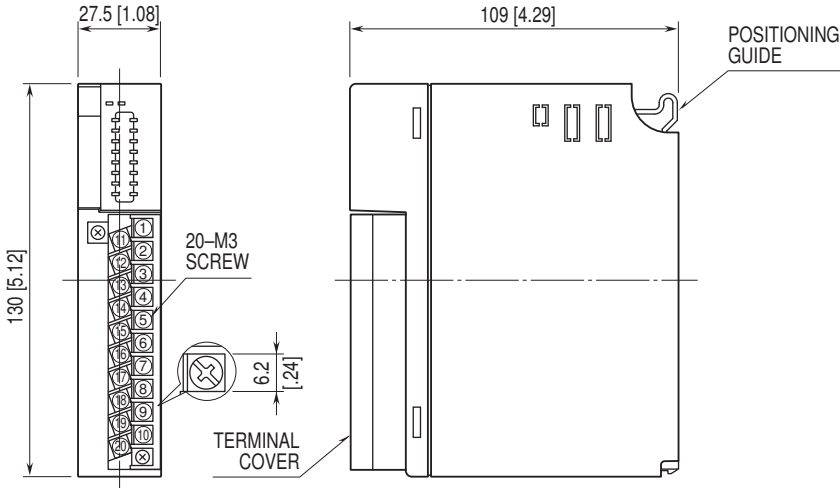

SCHEMATIC CIRCUITRY & CONNECTION DIAGRAM

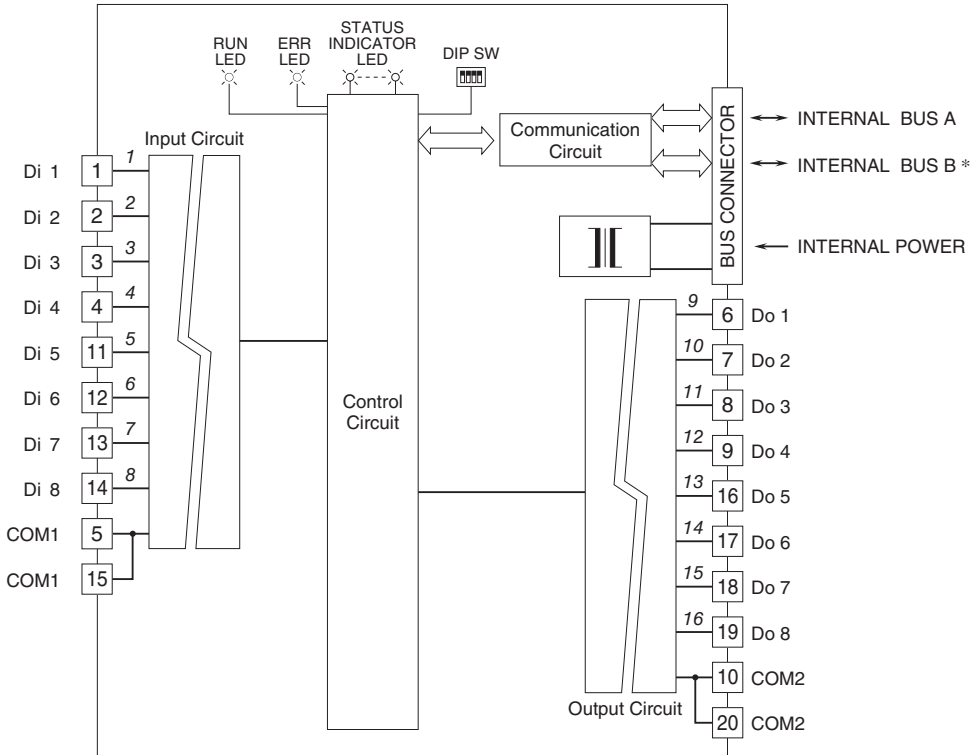

Numbers in italic indicate LED No.s assigned to the front panel LEDs.
 *For dual redundant communication.

Input Circuit

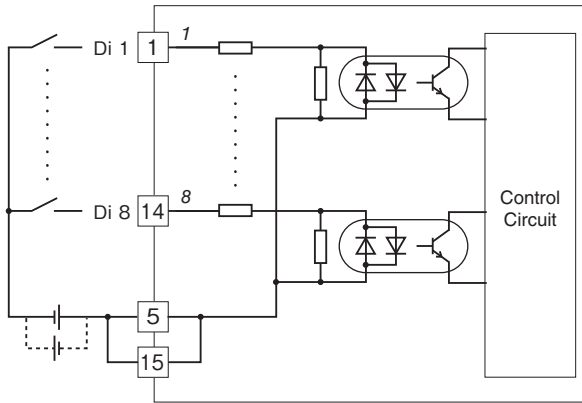

Output Circuit

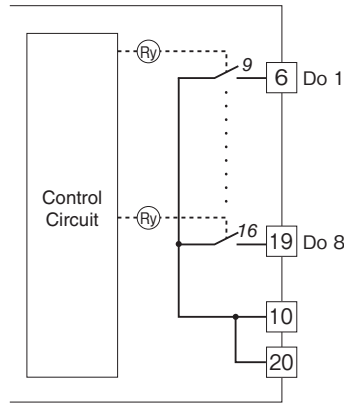

Specifications are subject to change without notice.