

Remote I/O R3 Series

AC CURRENT INPUT MODULE

(8 points, isolated, clamp-on current sensor type CLSB-R5 use)

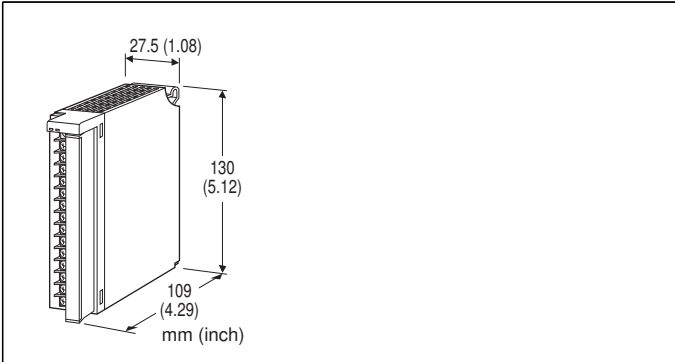

MODEL: R3-CT8C[1][2]

ORDERING INFORMATION

- Code number: R3-CT8C[1][2]
Specify a code from below for each of [1] and [2].
(e.g. R3-CT8CW/H/Q)
- Specify the specification for option code /Q
(e.g. /C01/SET)

NO. OF CHANNELS

8C: 8 channels, Sensor type CLSB-R5

[1] COMMUNICATION MODE

S: Single
W: Dual

[2] OPTIONS (multiple selections)

Frequency

blank: 45 - 65 Hz
/H: 200 Hz - 1.2 kHz

Other Options

blank: none
/Q: Option other than the above (specify the specification)

SPECIFICATIONS OF OPTION: Q (multiple selections)

COATING (For the detail, refer to M-System's web site.)

/C01: Silicone coating
/C02: Polyurethane coating
/C03: Rubber coating

EX-FACTORY SETTING

/SET: Preset according to the Ordering Information Sheet
(No. ESU-8442)

RELATED PRODUCTS

- PC configurator software (model: R3CON)
 - Zero/span adjustments for the conversion data are available using the R3CON. Downloadable at M-System's web site.
 - Clamp-on current sensor (model: CLSB-R5)
- The clamp-on current sensor, not included in the product package of the R3 module, must be ordered separately. Refer to the data sheet for the sensor for more information such as applicable wire diameter.

GENERAL SPECIFICATIONS

Connection

Internal bus: Via the Installation Base (model: R3-BSx)
Input: M3 separable screw terminal (torque 0.5 N·m)
Internal power: Via the Installation Base (model: R3-BSx)

Screw terminal: Nickel-plated steel

Isolation: Input 1 to input 2 to input 3 to input 4 to input 5 to input 6 to input 7 to input 8 to internal bus or internal power

Input range: 0 - 5 A AC, 0 - 1 A AC (Selectable with the side DIP SW per 4 channels)

Conversion rate: Selectable with the side DIP SW

RUN indicator: Bi-color (red/green) LED;
Red when the bus A operates normally;
Green when the bus B operates normally;
Amber when both buses operate normally.

ERR indicator: Bi-color (red/green) LED;
Red with input abnormality;
Green in normal operating conditions.

Low-end cutout: Converted as 0 % for the input below 1 % of range

INPUT SPECIFICATIONS

Input: 0 - 5 A AC, 0 - 1 A AC

Sensor

CLSB-R5: 0 - 5 A AC
Frequency: 45 - 65 Hz
(200 Hz - 1.2 kHz with Option /H)
Max. working voltage: 440 V AC (primary side)
Operational range: 5 - 115 % of rating

INSTALLATION

Operating temperature: -10 to +55°C (14 to 131°F)
Operating humidity: 30 to 90 %RH (non-condensing)
Atmosphere: No corrosive gas or heavy dust
Mounting: Installation Base (model: R3-BSx)
Weight: 250 g (0.55 lb)

PERFORMANCE

Conversion accuracy: Refer to the table at the end of this section.

Conversion rate: 160 / 80 / 40 / 20 msec. selectable

Data range: 0 - 10000 of the input range

Data allocation: 8

Current consumption: 100 mA

Temp. coefficient: $\pm 0.015\% / ^\circ\text{C}$ ($\pm 0.008\% / ^\circ\text{F}$)

Input response time: ≤ 0.5 sec. (0 - 90 %)

Insulation resistance: $\geq 100\ \text{M}\Omega$ with 500 V DC

Dielectric strength: 1000 V AC @ 1 minute (input 1 to input 2 to input 3 to input 4 to input 5 to input 6 to input 7 to input 8 to internal bus or internal power)

2000 V AC @ 1 minute (power input to FG; isolated on the power supply module)

Conversion accuracy

Rate	160 msec.	80 msec.	40 msec.	20 msec.
Accuracy	$\pm 0.5\%$	$\pm 0.5\%$	$\pm 1.0\%$	$\pm 2.0\%$

Except the accuracy of the sensor.

EXTERNAL VIEW

■ SIDE VIEW

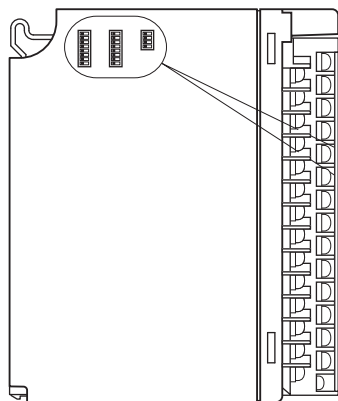

■ FRONT VIEW

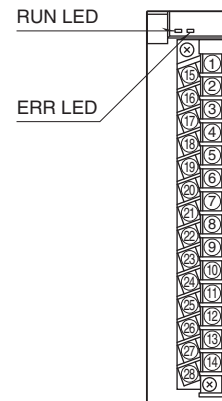

Functions

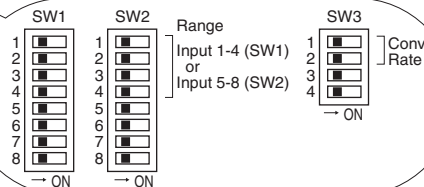

EXTERNAL DIMENSIONS & TERMINAL ASSIGNMENTS unit: mm (inch)

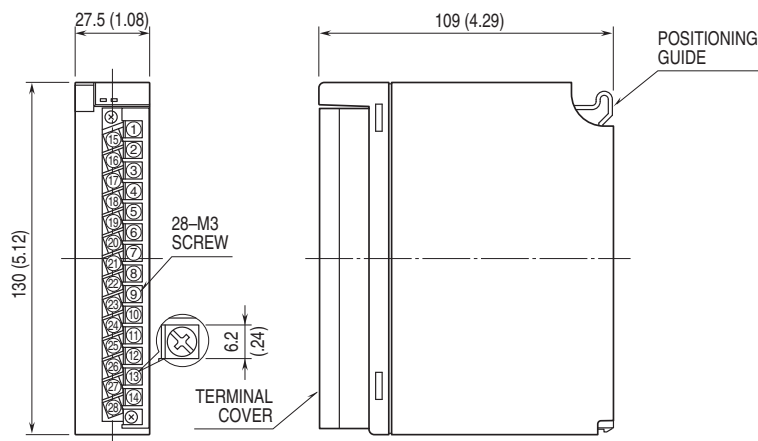

SCHEMATIC CIRCUITRY & CONNECTION DIAGRAM

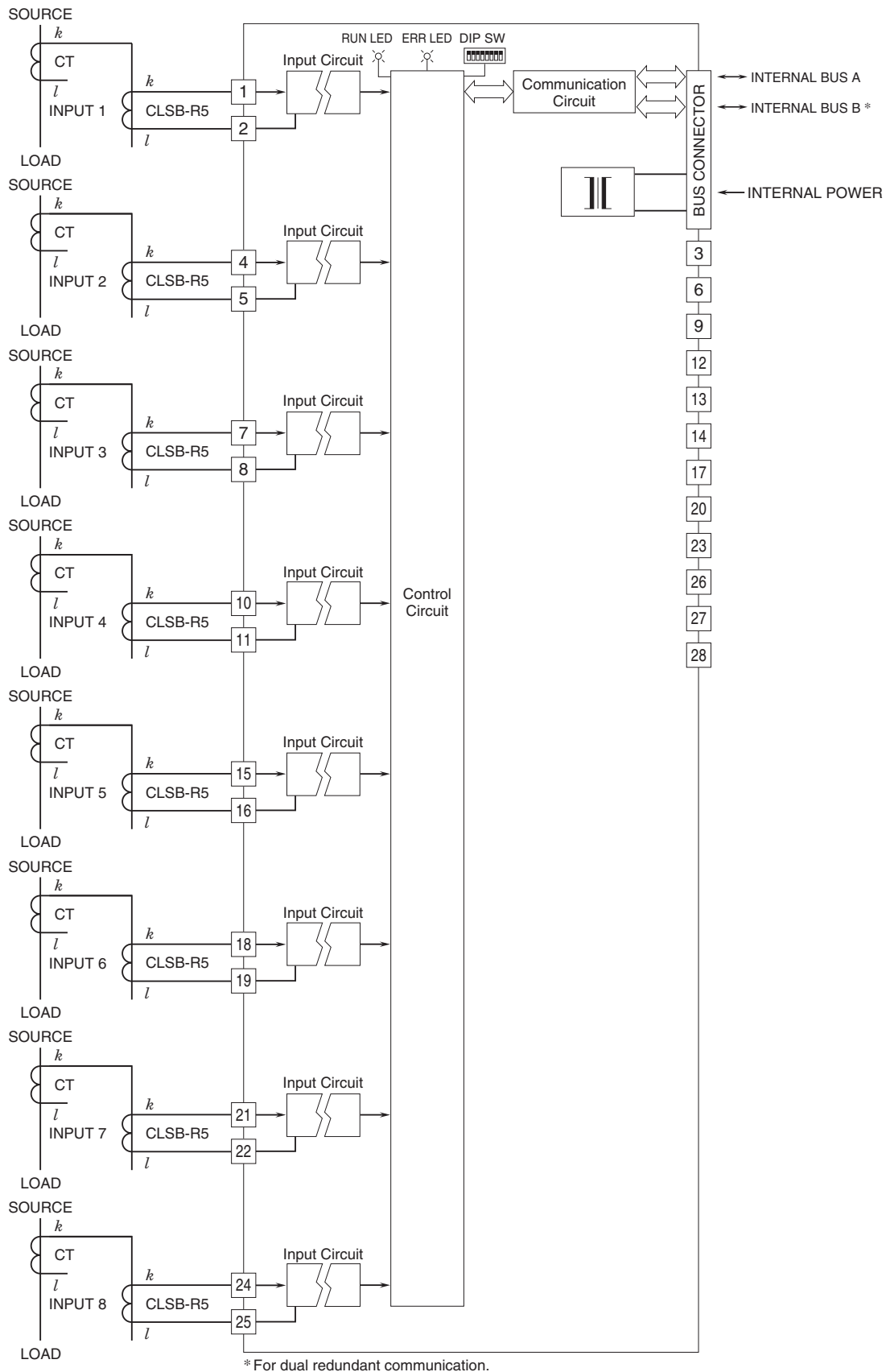



Specifications are subject to change without notice.