

**BEFORE USE ....**

Thank you for choosing M-System. Before use, please check contents of the package you received as outlined below.

If you have any problems or questions with the product, please contact M-System's Sales Office or representatives.

**■ PACKAGE INCLUDES:**

DC voltage input module.....(1)

**■ MODEL NO.**

Confirm Model No. marking on the product to be exactly what you ordered.

**■ INSTRUCTION MANUAL**

This manual describes necessary points of caution when you use this product, including installation, connection and basic maintenance procedures.

**POINTS OF CAUTION****■ CONFORMITY WITH EU DIRECTIVES**

- The equipment must be mounted inside the instrument panel of a metal enclosure.
- The actual installation environments such as panel configurations, connected devices, connected wires, may affect the protection level of this unit when it is integrated in a panel system. The user may have to review the CE requirements in regard to the whole system and employ additional protective measures to ensure the CE conformity.

**■ HOT SWAPPABLE MODULES**

- Replacing the module does not affect other modules on the same base. Thus, the module can be replaced while the power is ON. However, replacing multiple modules at once may greatly change live voltage levels. We highly recommend to replace them one by one.

**■ GENERAL PRECAUTIONS**

- DO NOT set the switches on the module while the power is supplied. The switches are used only for maintenance without the power.

**■ ENVIRONMENT**

- Indoor use.
- When heavy dust or metal particles are present in the air, install the unit inside proper housing with sufficient ventilation.
- Do not install the unit where it is subjected to continuous vibration. Do not subject the unit to physical impact.
- Environmental temperature must be within -10 to +55°C (14 to 131°F) with relative humidity within 30 to 90% RH in order to ensure adequate life span and operation.

**■ WIRING**

- Do not install cables close to noise sources (relay drive cable, high frequency line, etc.).
- Do not bind these cables together with those in which noises are present. Do not install them in the same duct.

**■ UNUSED INPUT CHANNELS**

- Set the unused channels to "Unused" with PC Configurator software: R3CON. For 1 – 5 V DC, unused channels left open with other settings may be equal to the input lower than -15 %, which sets a data abnormality at the PLC or the host device.

**■ AND ....**

- The unit is designed to function as soon as power is supplied, however, a warm up for 10 minutes is required for satisfying complete performance described in the data sheet.

**INSTALLATION**

Use the Installation Base (model: R3-BSx).

## COMPONENT IDENTIFICATION

### FRONT VIEW



#### Pin Assignment

B A  
20 20

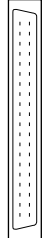

B A  
1 1

### SIDE VIEW

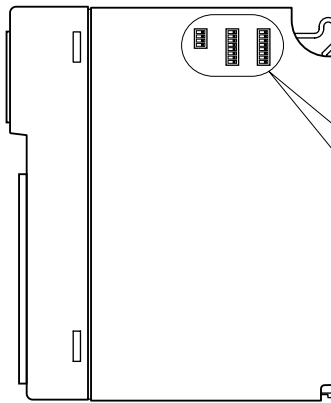

Input Connector

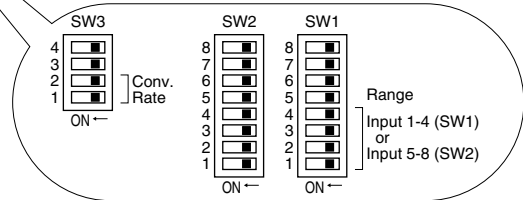

### STATUS INDICATOR LED

- RUN indicator:** Bi-color (red/green) LED;  
 Red when the bus A operates normally;  
 Green when the bus B operates normally;  
 Amber when both buses operate normally.
- ERR indicator:** Bi-color (red/green) LED;  
 Red with input circuit abnormality (AD converter response failure);  
 Green in normal operating conditions.

### SIDE DIP SW

(\*) Factory setting

#### Input Range: SW1, SW2 (selectable per 4 channels)

INPUT 1 through INPUT 4 (SW1)				RANGE
INPUT 5 through INPUT 8 (SW2)				
1	2	3	4	
OFF	OFF	OFF	OFF	-10 – +10V (*)
ON	OFF	OFF	OFF	-5 – +5V
ON	ON	OFF	OFF	0 – 10V
OFF	OFF	ON	OFF	0 – 5V
ON	OFF	ON	OFF	1 – 5V

#### Conversion Rate: SW3-1, 3-2

SW	CONVERSION RATE			
	100 ms (*)	50 ms	20 ms	10 ms
SW3-1	OFF	ON	OFF	ON
SW3-2	OFF	OFF	ON	ON

Note: Be sure to set unused SW1-5 through 1-8, SW2-5 through 2-8, SW3-3 and 3-4 to OFF.

## PC CONFIGURATOR

With configurator software, settings shown below are available.  
 Refer to the software manual of R3CON for detailed operation.

### CHANNEL INDIVIDUAL SETTING

PARAMETER	AVAILABLE RANGE	DEFAULT SETTING
Zero Scale	-32000 to +32000	0
Full Scale	-32000 to +32000	10000
Zero Adjust	-320.00 to +320.00	0.00
Full Adjust	-32000 to +32000	1.0000
Unused	0: Enable 1: Disable	0: Enable

# TERMINAL CONNECTIONS

Connect the unit as in the diagrams below.

## EXTERNAL DIMENSIONS unit: mm (inch)

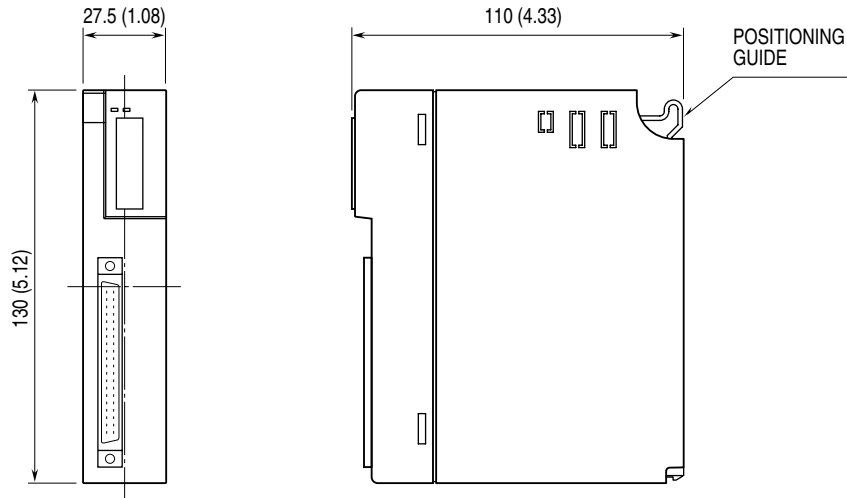

## CONNECTION DIAGRAM

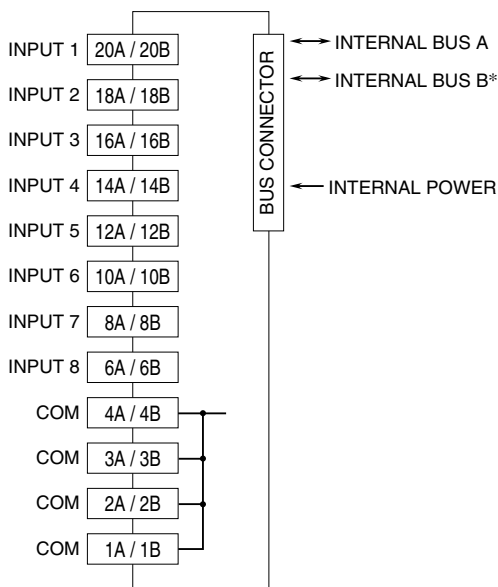

\*For dual redundant communication.

## INPUT CONNECTOR (40-pin)

PIN NO.	ASSIGNMENT	PIN NO.	ASSIGNMENT
1A	COM	1B	COM
2A	COM	2B	COM
3A	COM	3B	COM
4A	COM	4B	COM
5A	NC	5B	NC
6A	IN8	6B	IN8
7A	NC	7B	NC
8A	IN7	8B	IN7
9A	NC	9B	NC
10A	IN6	10B	IN6
11A	NC	11B	NC
12A	IN5	12B	IN5
13A	NC	13B	NC
14A	IN4	14B	IN4
15A	NC	15B	NC
16A	IN3	16B	IN3
17A	NC	17B	NC
18A	IN2	18B	IN2
19A	NC	19B	NC
20A	IN1	20B	IN1