

**BEFORE USE ....**

Thank you for choosing M-System. Before use, please check contents of the package you received as outlined below.

If you have any problems or questions with the product, please contact M-System's Sales Office or representatives.

**■ PACKAGE INCLUDES:**

DC current input module.....(1)

**■ MODEL NO.**

Confirm Model No. marking on the product to be exactly what you ordered.

**■ INSTRUCTION MANUAL**

This manual describes necessary points of caution when you use this product, including installation, connection and basic maintenance procedures.

**POINTS OF CAUTION****■ HOT SWAPPABLE MODULES**

- Replacing the module does not affect other modules on the same base. Thus, the module can be replaced while the power is ON. However, replacing multiple modules at once may greatly change live voltage levels. We highly recommend to replace them one by one.

**■ GENERAL PRECAUTIONS**

- DO NOT set the switches on the module while the power is supplied. The switches are used only for maintenance without the power.

**■ ENVIRONMENT**

- Indoor use.
- When heavy dust or metal particles are present in the air, install the unit inside proper housing with sufficient ventilation.
- Do not install the unit where it is subjected to continuous vibration. Do not subject the unit to physical impact.
- Environmental temperature must be within -10 to +55°C (14 to 131°F) with relative humidity within 30 to 90% RH in order to ensure adequate life span and operation.

**■ WIRING**

- Do not install cables close to noise sources (relay drive cable, high frequency line, etc.).
- Do not bind these cables together with those in which noises are present. Do not install them in the same duct.

**■ UNUSED INPUT CHANNELS**

- Set the unused channels to -20 – +20mA or 0 – 20mA range. Otherwise, set them as “Unused” with PC Configurator software: R3CON. Unused channels left open with 4 – 20mA setting are equal to the input lower than -15%, which sets a data abnormality at the PLC or the host device.

**■ AND ....**

- The unit is designed to function as soon as power is supplied, however, a warm up for 10 minutes is required for satisfying complete performance described in the data sheet.

**INSTALLATION**

Use the Installation Base (model: R3-BSx).

## COMPONENT IDENTIFICATION

### FRONT VIEW

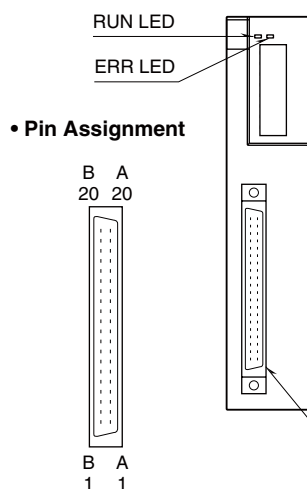

### SIDE VIEW

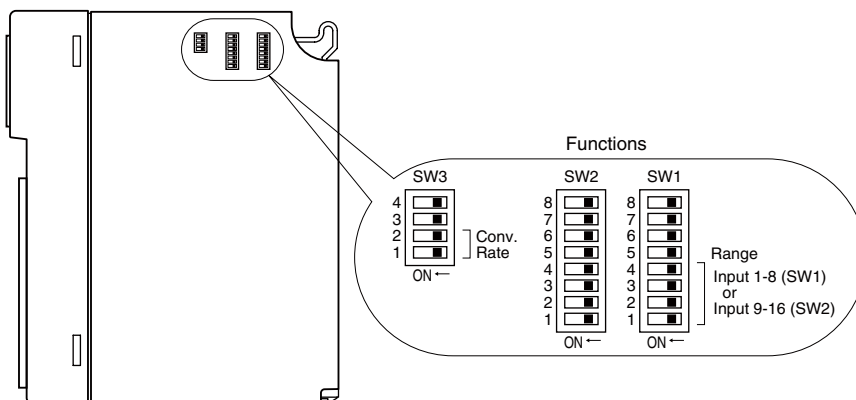

### STATUS INDICATOR LED

**RUN indicator:** Bi-color (red/green) LED;

Red when the bus A operates normally;  
Green when the bus B operates normally;  
Amber when both buses operate normally.

**ERR indicator:** Bi-color (red/green) LED;

Red with input circuit abnormality (AD converter response failure);  
Green in normal operating conditions.

### SIDE DIP SW

(\*) Factory setting

• **Input Range: SW1, SW2** (selectable per 8 channels)

INPUT 1 through INPUT 8 (SW1)				RANGE
INPUT 9 through INPUT 16 (SW2)				
1	2	3	4	
OFF	OFF	OFF	OFF	4 – 20mA (*)
ON	OFF	OFF	OFF	0 – 20mA
OFF	ON	OFF	OFF	-20 – +20mA

• **Conversion Rate: SW3-1, 3-2**

SW	CONVERSION RATE			
	100 ms (*)	50 ms	20 ms	10 ms
SW3-1	OFF	ON	OFF	ON
SW3-2	OFF	OFF	ON	ON

Note: Be sure to set unused SW1-5 through 1-8, SW2-5 through 2-8, SW3-3 and 3-4 to OFF.

## PC CONFIGURATOR

With configurator software, settings shown below are available.  
Refer to the software manual of R3CON for detailed operation.

### CHANNEL INDIVIDUAL SETTING

PARAMETER	AVAILABLE RANGE	DEFAULT SETTING
Zero Scale	-32000 to +32000	0
Full Scale	-32000 to +32000	10000
Zero Adjust	-320.00 to +320.00	0.00
Full Adjust	-32000 to +32000	1.0000
Unused	0: Enable 1: Disable	0: Enable

## TERMINAL CONNECTIONS

Connect the unit as in the diagram below.

### EXTERNAL DIMENSIONS unit: mm (inch)

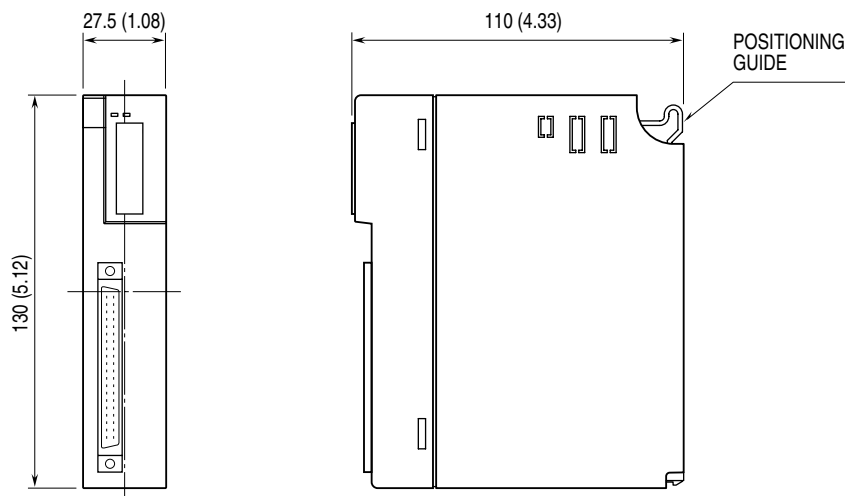

### CONNECTION DIAGRAM

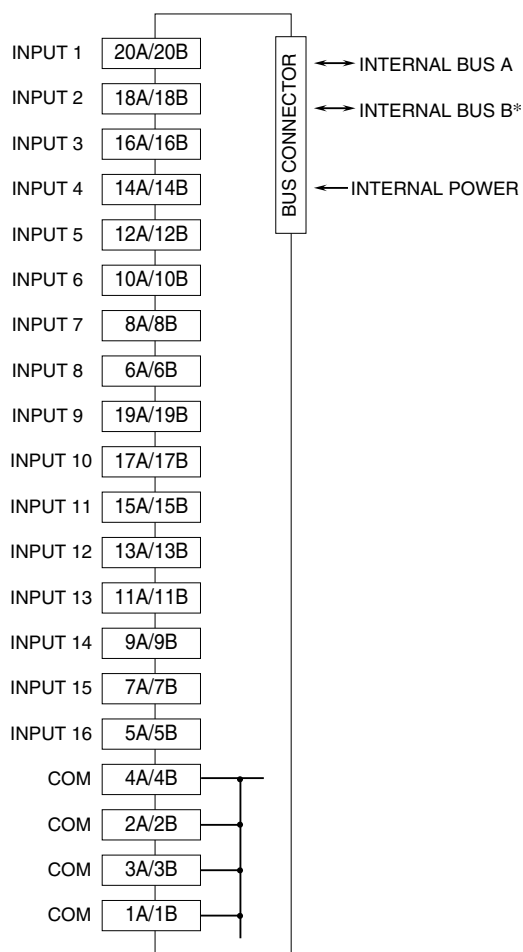

\*For dual redundant communication.

### INPUT CONNECTOR (40-pin)

PIN NO.	ASSIGNMENT	PIN NO.	ASSIGNMENT
1A	COM	1B	COM
2A	COM	2B	COM
3A	COM	3B	COM
4A	COM	4B	COM
5A	IN16	5B	IN16
6A	IN8	6B	IN8
7A	IN15	7B	IN15
8A	IN7	8B	IN7
9A	IN14	9B	IN14
10A	IN6	10B	IN6
11A	IN13	11B	IN13
12A	IN5	12B	IN5
13A	IN12	13B	IN12
14A	IN4	14B	IN4
15A	IN11	15B	IN11
16A	IN3	16B	IN3
17A	IN10	17B	IN10
18A	IN2	18B	IN2
19A	IN9	19B	IN9
20A	IN1	20B	IN1