

**4 – 20mA INPUT MODULE**

(2-wire transmitter excitation supply; 4 points, isolated, connector type)

MODEL **R3Y-DS4****BEFORE USE ....**

Thank you for choosing M-System. Before use, please check contents of the package you received as outlined below.

If you have any problems or questions with the product, please contact M-System's Sales Office or representatives.

**■ PACKAGE INCLUDES:**

4 – 20mA input module.....(1)

**■ MODEL NO.**

Confirm Model No. marking on the product to be exactly what you ordered.

**■ INSTRUCTION MANUAL**

This manual describes necessary points of caution when you use this product, including installation, connection and basic maintenance procedures.

**POINTS OF CAUTION****■ HOT SWAPPABLE MODULES**

- Replacing the module does not affect other modules on the same base. Thus, the module can be replaced while the power is ON. However, replacing multiple modules at once may greatly change live voltage levels. We highly recommend to replace them one by one.

**■ GENERAL PRECAUTIONS**

- DO NOT set the switches on the module while the power is supplied. The switches are used only for maintenance without the power.

**■ ENVIRONMENT**

- Indoor use
- When heavy dust or metal particles are present in the air, install the unit inside proper housing with sufficient ventilation.
- Do not install the unit where it is subjected to continuous vibration. Do not subject the unit to physical impact.
- Environmental temperature must be within -10 to +55°C (14 to 131°F) with relative humidity within 30 to 90% RH in order to ensure adequate life span and operation.

**■ WIRING**

- Do not install cables close to noise sources (relay drive cable, high frequency line, etc.).
- Do not bind these cables together with those in which noises are present. Do not install them in the same duct.

**■ UNUSED INPUT CHANNELS**

- Set the unused channels to "Unused" with PC Configurator software: R3CON. Unused channels left open may be equal to the input lower than -15%, which sets a data abnormality at the PLC or the host device.

**■ AND ....**

- The unit is designed to function as soon as power is supplied, however, a warm up for 10 minutes is required for satisfying complete performance described in the data sheet.

**INSTALLATION**

Use the Installation Base (model: R3-BSx).

## COMPONENT IDENTIFICATION

### FRONT VIEW

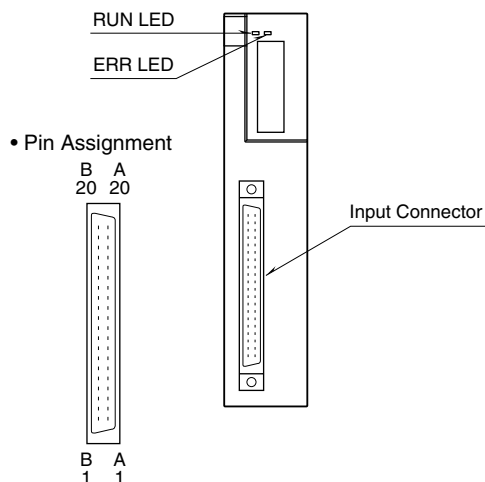

### SIDE VIEW

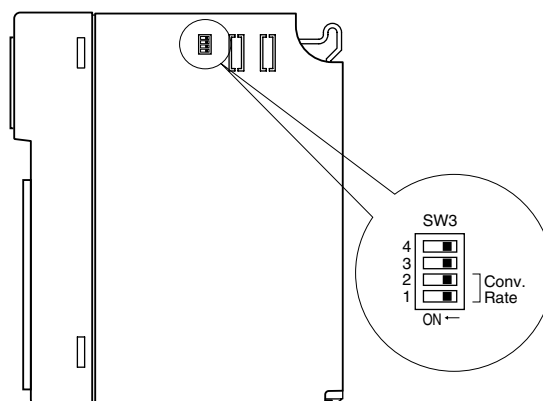

### STATUS INDICATOR LED

**RUN indicator:** Bi-color (red/green) LED;

Red when the bus A operates normally;  
Green when the bus B operates normally;  
Amber when both buses operate normally.

**ERR indicator:** Bi-color (red/green) LED;

Red with input circuit abnormality (AD converter response failure);  
Green in normal operating conditions.

### SIDE DIP SW

• Conversion Rate: SW3-1, 3-2

SW	CONVERSION RATE			
	80 ms (*)	40 ms	20 ms	10 ms
SW3-1	OFF	ON	OFF	ON
SW3-2	OFF	OFF	ON	ON

(\*) Factory setting

Note: Be sure to set unused SW3-3 and 3-4 to OFF.

## PC CONFIGURATOR

With configurator software, settings shown below are available.  
Refer to the software manual of R3CON for detailed operation.

### CHANNEL INDIVIDUAL SETTING

PARAMETER	AVAILABLE RANGE	DEFAULT SETTING
Zero Scale	-32000 to +32000	0
Full Scale	-32000 to +32000	10000
Zero Adjust	-320.00 to +320.00	0.00
Full Adjust	-32000 to +32000	1.0000
Unused	0: Enable 1: Disable	0: Enable

## TERMINAL CONNECTIONS

Connect the unit as in the diagram below.

### EXTERNAL DIMENSIONS unit: mm (inch)

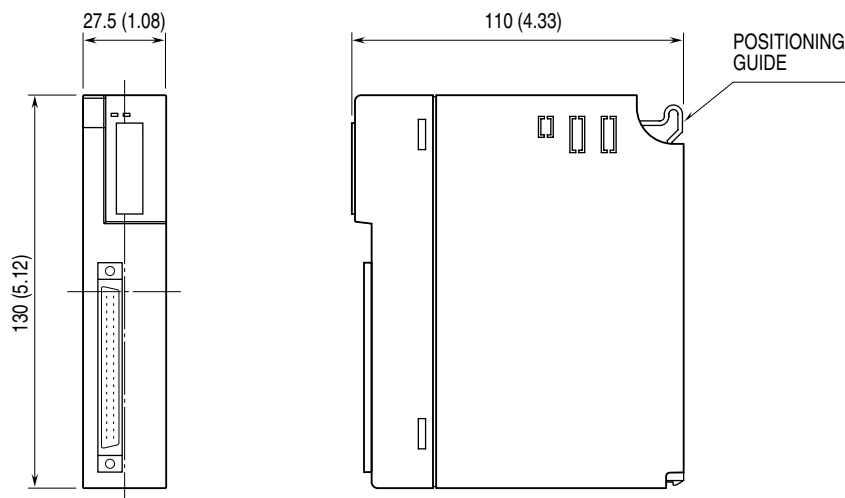

### CONNECTION DIAGRAM

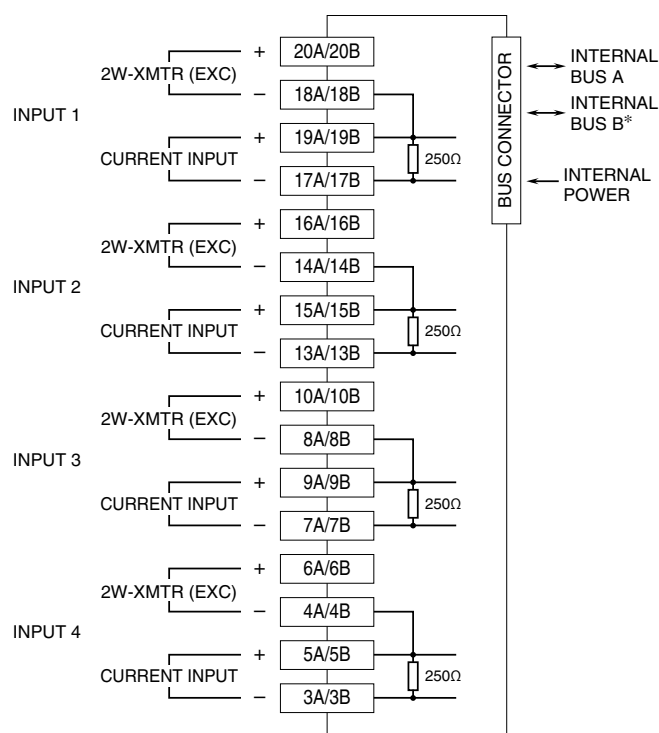

\*For dual redundant communication.

### INPUT CONNECTOR (40-pin)

PIN No.	ASSIGNMENT	PIN No.	ASSIGNMENT
1A	NC	1B	NC
2A	NC	2B	NC
3A	- IN4	3B	- IN4
4A	- 2-WIRE XMTR4	4B	- 2-WIRE XMTR4
5A	+ IN4	5B	+ IN4
6A	+ 2-WIRE XMTR4	6B	+ 2-WIRE XMTR4
7A	- IN3	7B	- IN3
8A	- 2-WIRE XMTR3	8B	- 2-WIRE XMTR3
9A	+ IN3	9B	+ IN3
10A	+ 2-WIRE XMTR3	10B	+ 2-WIRE XMTR3
11A	NC	11B	NC
12A	NC	12B	NC
13A	- IN2	13B	- IN2
14A	- 2-WIRE XMTR2	14B	- 2-WIRE XMTR2
15A	+ IN2	15B	+ IN2
16A	+ 2-WIRE XMTR2	16B	+ 2-WIRE XMTR2
17A	- IN1	17B	- IN1
18A	- 2-WIRE XMTR1	18B	- 2-WIRE XMTR1
19A	+ IN1	19B	+ IN1
20A	+ 2-WIRE XMTR1	20B	+ 2-WIRE XMTR1

#### Caution

Input value is less than -15% for the open input, then the host PC/PLC recognizes and configures this as error. The unused channels can be specified and configured with the PC Configurator Software (model: R3CON).