

DISCRETE INPUT MODULE
(Di 16 points; with excitation supply, connector type)MODEL **R3Y-DA16****BEFORE USE**

Thank you for choosing M-System. Before use, please check contents of the package you received as outlined below.

If you have any problems or questions with the product, please contact M-System's Sales Office or representatives.

■ PACKAGE INCLUDES:

Discrete input module.....(1)

■ MODEL NO.

Confirm Model No. marking on the product to be exactly what you ordered.

■ INSTRUCTION MANUAL

This manual describes necessary points of caution when you use this product, including installation, connection and basic maintenance procedures.

POINTS OF CAUTION**■ CONFORMITY WITH EU DIRECTIVES**

- The equipment must be mounted inside the instrument panel of a metal enclosure.
- The actual installation environments such as panel configurations, connected devices, connected wires, may affect the protection level of this unit when it is integrated in a panel system. The user may have to review the CE requirements in regard to the whole system and employ additional protective measures to ensure the CE conformity.

■ HOT SWAPPABLE MODULES

- Replacing the module does not affect other modules on the same base. Thus, the module can be replaced while the power is ON. However, replacing multiple modules at once may greatly change live voltage levels. We highly recommend to replace them one by one.

■ GENERAL PRECAUTIONS

- DO NOT set the switches on the module while the power is supplied. The switches are used only for maintenance without the power.

■ ENVIRONMENT

- Indoor use.
- When heavy dust or metal particles are present in the air, install the unit inside proper housing with sufficient ventilation.
- Do not install the unit where it is subjected to continuous vibration. Do not subject the unit to physical impact.
- Environmental temperature must be within -10 to +55°C (14 to 131°F) with relative humidity within 30 to 90% RH in order to ensure adequate life span and operation.

■ WIRING

- Do not install cables close to noise sources (relay drive cable, high frequency line, etc.).
- Do not bind these cables together with those in which noises are present. Do not install them in the same duct.

INSTALLATION

Use the Installation Base (model: R3-BSx).

COMPONENT IDENTIFICATION

FRONT VIEW

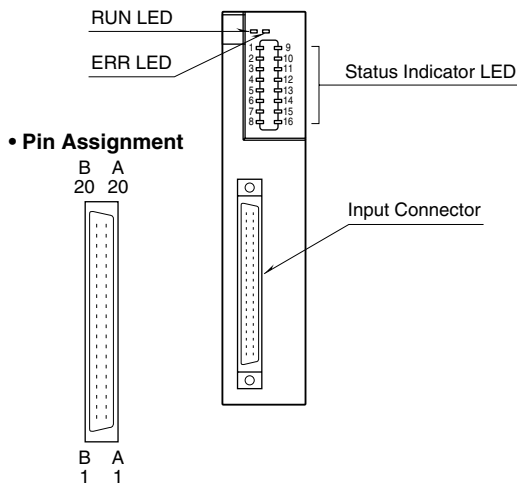

SIDE VIEW

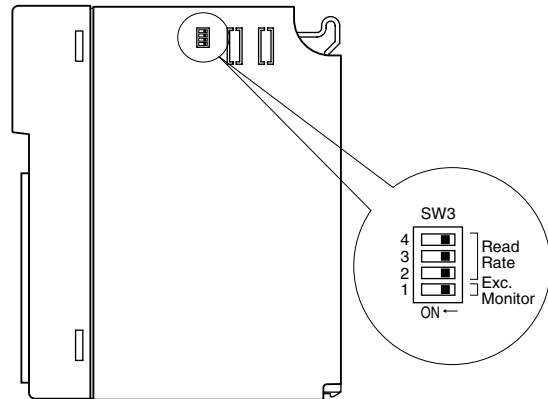

STATUS INDICATOR LED

- RUN indicator:** Bi-color (red/green) LED;
Red when the bus A operates normally;
Green when the bus B operates normally;
Amber when both buses operate normally.
- ERR indicator:** Bi-color (red/green) LED;
Red with excitation abnormality;
Green in normal operating conditions.
- Input status indicator:** Red LED; turns on with the input ON.

SIDE DIP SW

(*) Factory setting

Excitation Monitor: SW3-1

SW	EXCITATION MONITOR	
	WITH (*)	WITHOUT
SW3-1	OFF	ON

Read Rate: SW3-2, 3-3, 3-4

SW	READ RATE (≤ msec.)							
	10 (*)	1	5	20	50	70	100	200
SW3-2	OFF	ON	OFF	ON	OFF	ON	OFF	ON
SW3-3	OFF	OFF	ON	ON	OFF	OFF	ON	ON
SW3-4	OFF	OFF	OFF	OFF	ON	ON	ON	ON

TERMINAL CONNECTIONS

Connect the unit as in the diagram below.

EXTERNAL DIMENSIONS unit: mm (inch)

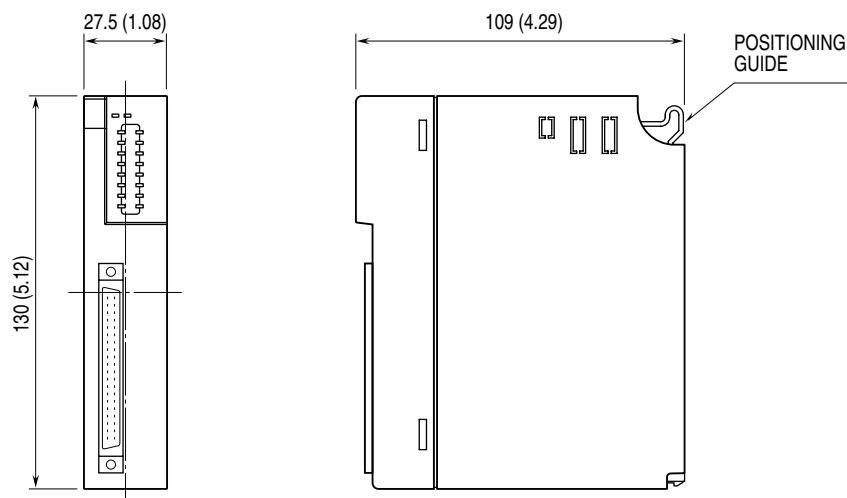

CONNECTION DIAGRAM

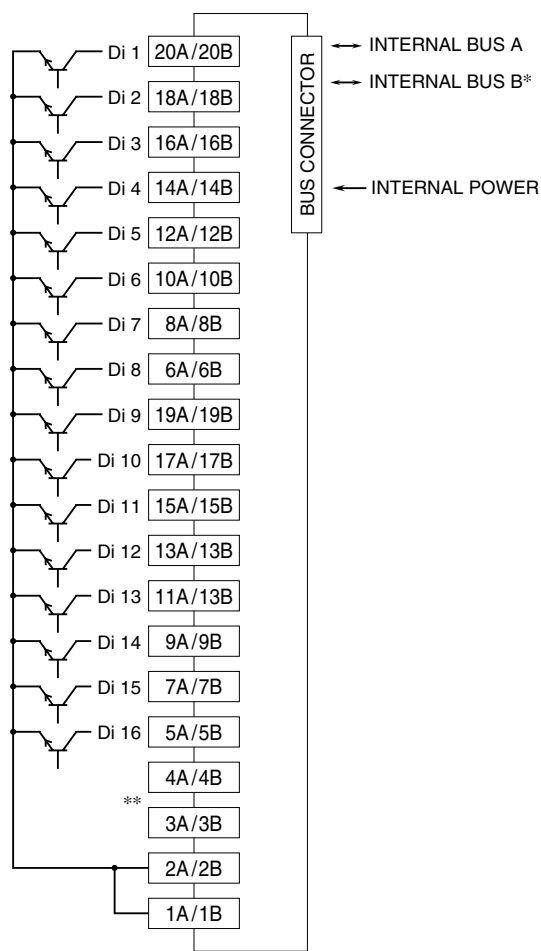

* For dual redundant communication.

**DO NOT connect to the pins 4A/4B or 3A/3B.

INPUT CONNECTOR (40-pin)

PIN NO.	ASSIGNMENT	PIN NO.	ASSIGNMENT
1A	0V	1B	0V
2A	0V	2B	0V
3A	NC	3B	NC
4A	NC	4B	NC
5A	Di 16	5B	Di 16
6A	Di 8	6B	Di 8
7A	Di 15	7B	Di 15
8A	Di 7	8B	Di 7
9A	Di 14	9B	Di 14
10A	Di 6	10B	Di 6
11A	Di 13	11B	Di 13
12A	Di 5	12B	Di 5
13A	Di 12	13B	Di 12
14A	Di 4	14B	Di 4
15A	Di 11	15B	Di 11
16A	Di 3	16B	Di 3
17A	Di 10	17B	Di 10
18A	Di 2	18B	Di 2
19A	Di 9	19B	Di 9
20A	Di 1	20B	Di 1

FUNCTIONS

EXCITATION MONITOR

Enabled/disabled with DIP switch setting.

Excitation Monitor ON

The input is held at the last status when the loss of excitation is detected.

Excitation Monitor OFF

All input signals are turned off when the loss of excitation is detected.