

MULTI POWER INPUT MODULE
(clamp-on current sensor type CLSE use)

MODEL **R3-WTU**

BEFORE USE

Thank you for choosing M-System. Before use, please check contents of the package you received as outlined below. If you have any problems or questions with the product, please contact M-System's Sales Office or representatives.

■ PACKAGE INCLUDES:

Multi power input module(1)

■ MODEL NO.

Confirm Model No. marking on the product to be exactly what you ordered.

■ INSTRUCTION MANUAL

This manual describes necessary points of caution when you use this product, including installation, connection and basic maintenance procedures.

In order to set up the software setting of this module, PC Configurator Software (model: R3CON) is required. For more information, please refer to the users manual for the R3CON.

The R3CON PC Configurator Software is downloadable at M-System's web site: <http://www.m-system.co.jp>.

POINTS OF CAUTION

■ HOT SWAPPABLE MODULES

- Replacing the module does not affect other modules on the same base. Thus, the module can be replaced while the power is ON. However, replacing multiple modules at once may greatly change live voltage levels. We highly recommend to replace them one by one.

■ ENVIRONMENT

- Indoor use.
- When heavy dust or metal particles are present in the air, install the unit inside proper housing with sufficient ventilation.
- Do not install the unit where it is subjected to continuous vibration. Do not subject the unit to physical impact.
- Environmental temperature must be within -10 to +55°C (14 to 131°F) with relative humidity within 30 to 90% RH in order to ensure adequate life span and operation.

■ WIRING

- Do not install cables close to noise sources (relay drive cable, high frequency line, etc.).
- Do not bind these cables together with those in which noises are present. Do not install them in the same duct.

■ AND

- The unit is designed to function as soon as power is supplied, however, a warm up for 10 minutes is required for satisfying complete performance described in the data sheet.
- Dismount the module from the base before disconnecting the connector.

COMPONENT IDENTIFICATION

■ FRONT VIEW

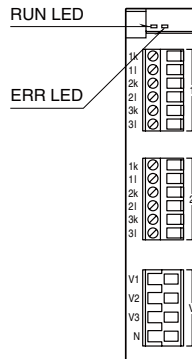

■ STATUS INDICATOR LED

- RUN indicator:** Bi-color (red/green) LED;
Red when the internal bus operates normally.
- ERR indicator:** Bi-color (red/green) LED;
Red with input abnormality (input $\geq 120\%$, frequency out of 45 – 65 Hz range);
Green in normal operating conditions.

INSTALLATION

Use the Installation Base (model: R3-BSx).
Be sure to use the R3-BSW base with free address setting capability with Option /D.

TERMINAL CONNECTIONS

Connect the unit as in the diagrams below.

EXTERNAL DIMENSIONS unit: mm (inch)

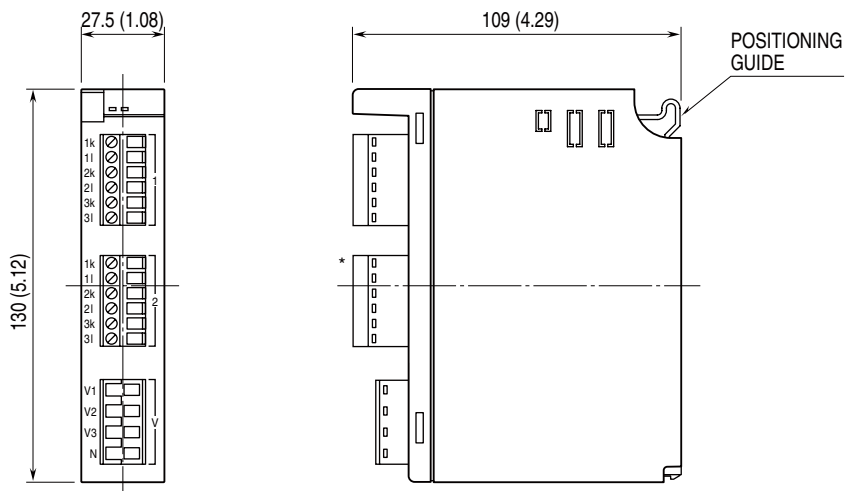

*Provided only with two circuits option.

■ CONNECTION DIAGRAM

■ SINGLE-PHASE/2-WIRE

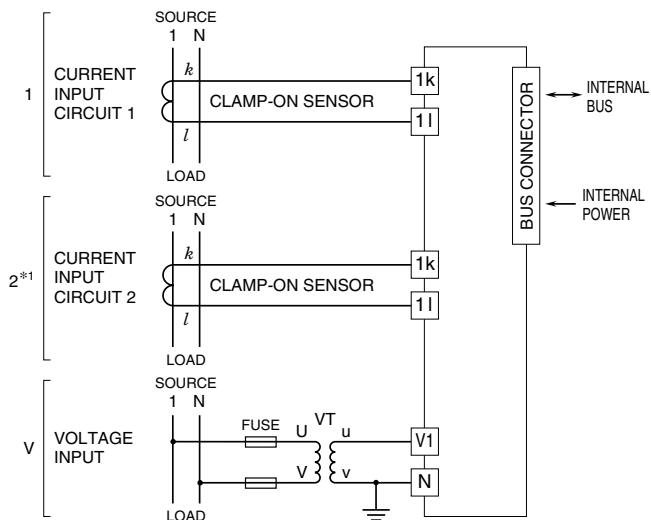

■ SINGLE-PHASE/3-WIRE

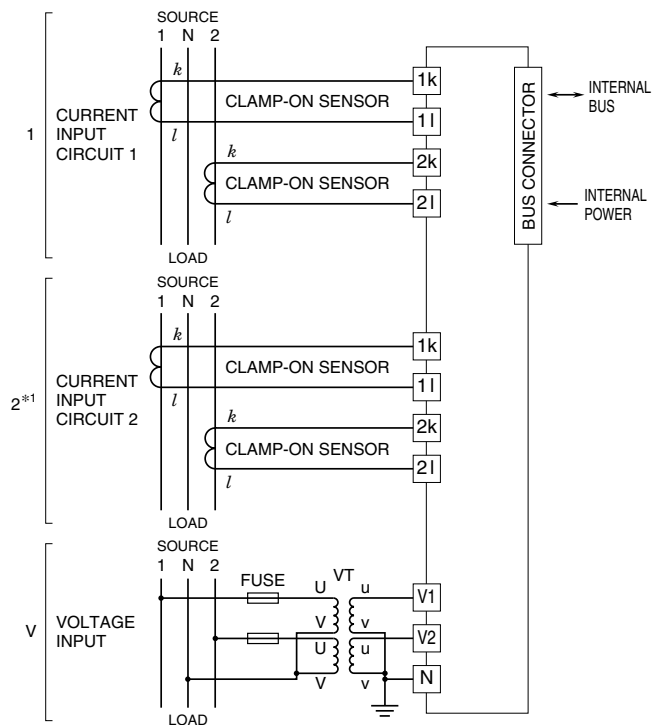

■ THREE-PHASE/3-WIRE, BALANCED LOAD

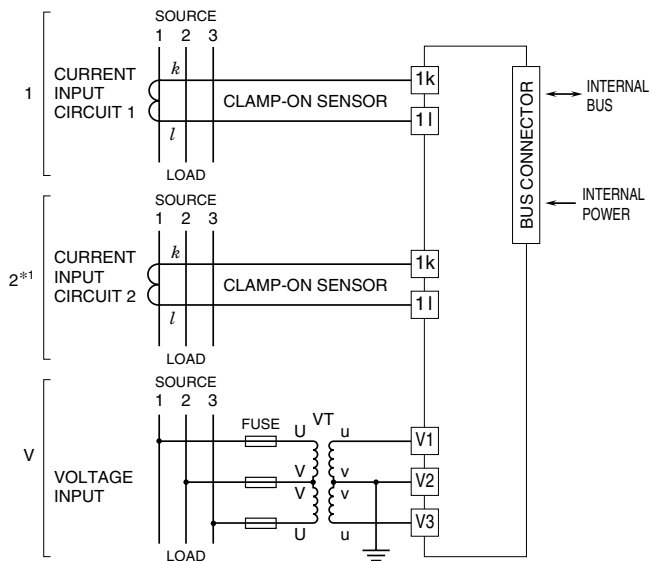

■ THREE-PHASE/3-WIRE, UNBALANCED LOAD

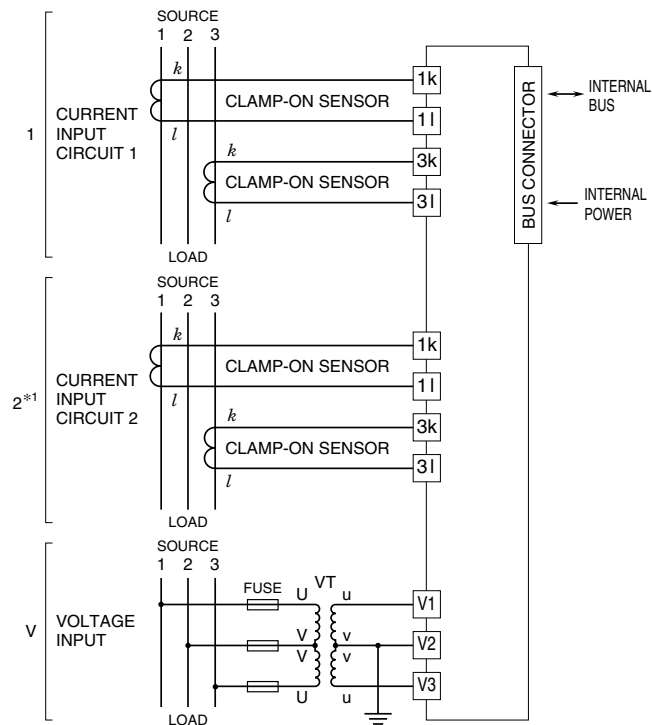

No need of grounding for a low voltage circuit.
 *1. Provided only with two circuits option.

■ THREE-PHASE/4-WIRE, BALANCED LOAD

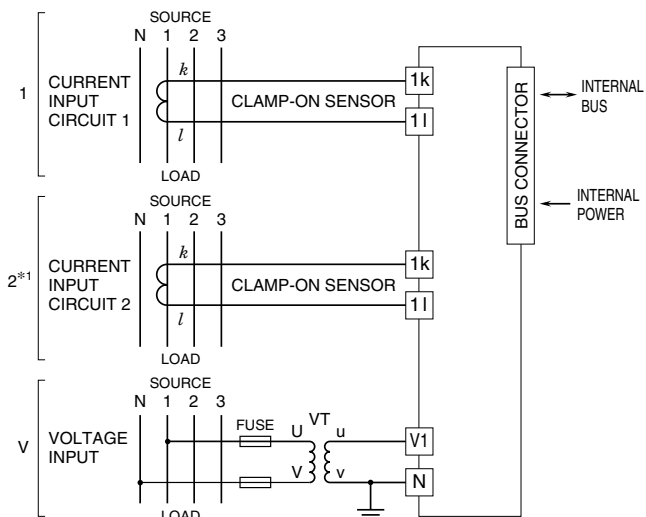

■ THREE-PHASE/4-WIRE, UNBALANCED LOAD

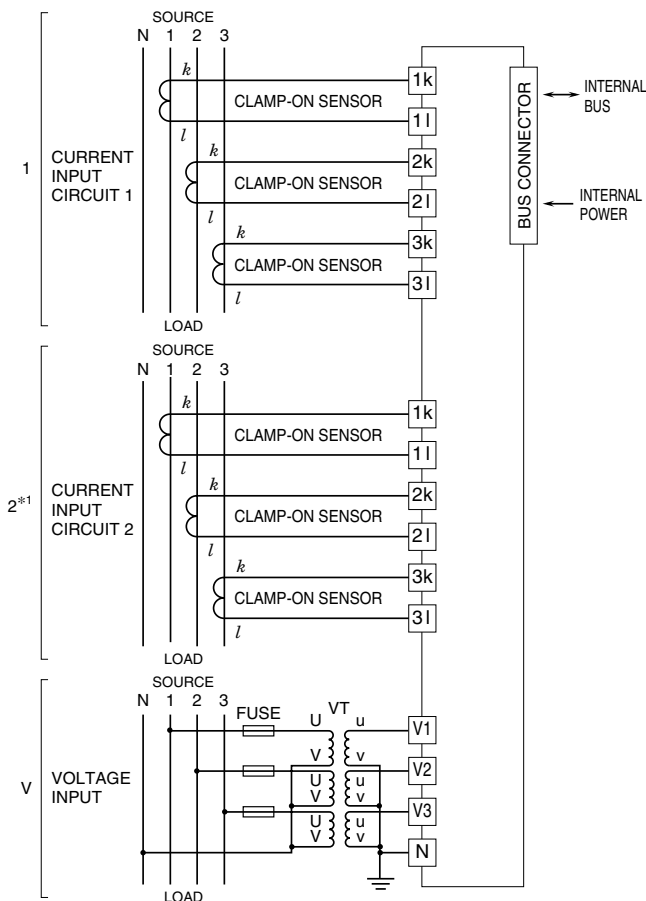

No need of grounding for a low voltage circuit.

*1. Provided only with two circuits option.

WIRING INSTRUCTIONS

■ EURO TYPE CONNECTOR TERMINAL

• Voltage input

Applicable wire size: dia. ≤ 2.5 , $0.5 - 3.5 \text{ mm}^2$

Stripped length: 7 mm

• Current input

Applicable wire size: dia. ≤ 2.4 , $0.5 - 3.5 \text{ mm}^2$

Stripped length: 10 mm

SETTING

■ RESET SETTING

PARAMETER	SELECTIONS
Reset	Reset all energy values Reset MAX / MIN values, Current (present value) Reset MAX / MIN values, other than Current (present value) Reset AVG (Demand) values

■ DEMAND SETTING

PARAMETER	SELECTIONS	UNIT
System configuration	Single-phase / 2-wire (1CT) Single-phase / 3-wire (2CT) 3-phase / 3-wire, balanced load (1CT) 3-phase / 3-wire, unbalanced load (2CT) 3-phase / 4-wire, balanced load (1CT) 3-phase / 4-wire, unbalanced load (3CT) (*)	—
CT rating, Primary	1 to 20 000 : Current (A) Selectable only with the CLSE-R5 Factory setting : 5	A
Current sensor type	CLSE-R5 (5A) (*) CLSE-05 (50A) CLSE-10 (100A) CLSE-20 (200A) CLSE-40 (400A) CLSE-60 (600A)	—
VT rating, Primary	50 to 400 000 : Voltage (V) Factory setting : 110	V
VT rating, Secondary	50 to 500 : Voltage (V) Factory setting : 110	V
Frequency input	Voltage (*) Current	—
Low-end cutout, Current	0 to 999 : Rated current × 0.001 × Specified value Factory setting : 10	%/10
Low-end cutout, Voltage	0 to 999 : Rated voltage × 0.001 × Specified value Factory setting : 10	%/10

(*) Factory setting

■ DEMAND SETTING

PARAMETER	SELECTIONS	UNIT
Average (demand) current update interval	1 to 60 Factory setting : 30	Minutes
Average (demand) power update interval	1 to 60 Factory setting : 30	Minutes

■ RESET SETTING

PARAMETER	SELECTIONS
Power factor (PF1 through PF3, PF) sign	Standard (IEC) : Identical to the active energy (*) Special type 1 (IEEE) : Positive in LAG, Negative in LEAD
Reactive power (Q1 through Q3, Q) sign	Standard (IEC) : Positive from [PF = 1.0] to 180° in LAG direction; Negative for the other direction (*) Specialtype 1 : Positive in LAG, Negative in LEAD
Apparent power (S) calculation	Standard : $S = \sqrt{P^2 + Q^2}$ (*) Sum : $S = S1 + S2 + S3$

(*) Factory setting

MEASURED VARIABLES

PC Configurator software (model: R3CON) is used to set scaled ranges, word length and number of systems.

Measured variables, except for the nth harmonic distortion, are read out as signed 16-bit or 32-bit integer.

Each variable has different engineering unit (Refer to the table below). For example, when 40000 is read for the 1 – N delta voltage, the actual voltage value equals to $400.0V = 40000 \times 0.01$, as the engineering unit for this item is V/100 (0.01V).

Readable range for each parameter depends upon the parameter type, as shown in the tables below. For example, Current unit is applied to Line current or Neutral current, and Voltage unit is applied to the 1 – N delta voltage or the minimum value voltage.

■ 1-WORD SETTING

PARAMETER	TYPE	UNIT	RANGE
Current	I	mA	0 to 30 000 × 10 ^{0..3} mA
Voltage	U	V/100	0 to 300.00 × 10 ^{0..3} V
Active power	P	W	-30 000 to 30 000 × 10 ^{0..3} W
Reactive power	Q	var	-30 000 to 30 000 × 10 ^{0..3} var
Apparent power	S	VA	0 to 30 000 × 10 ^{0..3} VA
Power factor	PF	%/100	-100.00 to +100.00 % (-1.0000 to +1.0000)
Frequency	F	Hz/100	0 or 40.00 Hz to 70.00 Hz
Active energy	EP	kWh/10	0 to 3276.7 × 10 ^{0..3} kWh ^{*1}
Reactive energy	EQ	kvarh/10	0 to 3276.7 × 10 ^{0..3} kvarh ^{*1}
Apparent energy	ES	kVAh/10	0 to 3276.7 × 10 ^{0..3} kVAh ^{*1}
Energy count time	C	h/10	0 to 3276.7 × 10 ^{0..3} hours ^{*1}
Harmonic	H	%/10	0 to 999.9%

*1. Not reset to 0 when exceeding the max. value. Be sure to use within the range from 0 to 3276.7 × 10^{0..3}.

■ 2-WORD SETTING

PARAMETER	TYPE	UNIT	RANGE
Current	I	mA	0 to 2 000 000 000 mA
Voltage	U	V/100	0 to 20 000 000.00 V
Active power	P	W	-2 000 000 000 to 2 000 000 000 W
Reactive power	Q	var	-2 000 000 000 to 2 000 000 000 var
Apparent power	S	VA	0 to 2 000 000 000 VA
Power factor	PF	%/100	-100.00 to +100.00 % (-1.0000 to +1.0000)
Frequency	F	Hz/100	0 or 40.00 Hz to 70.00 Hz
Active energy	EP	kWh/10	0 to 99 999 999.9 kWh ^{*1}
Reactive energy	EQ	kvarh/10	0 to 99 999 999.9 kvarh ^{*1}
Apparent energy	ES	kVAh/10	0 to 99 999 999.9 kVAh ^{*1}
Energy count time	C	h/10	0 to 99 999 999.9 hours ^{*1}
Harmonic	H	%/10	0 to 999.9%

*1. Reset to 0 when exceeding the max. value.

■ MOMENTARY VALUE

WORD	ID	PARAMETER	TYPE
1 or 2	I	Current	I
1 or 2	U	Voltage	U
1 or 2	P	Active power	P
1 or 2	Q	Reactive power	Q
1 or 2	S	Apparent power	S
1 or 2	PF	Power factor	PF
1 or 2	F	Frequency	F
1 or 2	DIR	Phase difference direction (0 = inductive or lag, 1 = capacitive or lead)	—
1 or 2	I1	Current, Line 1	I
1 or 2	I2	Current, Line 2	I
1 or 2	I3	Current, Line 3	I
1 or 2	IN	Neutral current	I
1 or 2	U12	Delta voltage, 1 – 2	U
1 or 2	U23	Delta voltage, 2 – 3	U

WORD	ID	PARAMETER	TYPE
1 or 2	U31	Delta voltage, 3 – 1	U
1 or 2	U1N	Phase voltage, Phase 1	U
1 or 2	U2N	Phase voltage, Phase 2	U
1 or 2	U3N	Phase voltage, Phase 3	U
1 or 2	P1	Active power, Phase 1	P
1 or 2	P2	Active power, Phase 2	P
1 or 2	P3	Active power, Phase 3	P
1 or 2	Q1	Reactive power, Phase 1	Q
1 or 2	Q2	Reactive power, Phase 2	Q
1 or 2	Q3	Reactive power, Phase 3	Q
1 or 2	S1	Apparent power, Phase 1	S
1 or 2	S2	Apparent power, Phase 2	S
1 or 2	S3	Apparent power, Phase 3	S
1 or 2	PF1	Power factor, Phase 1	PF
1 or 2	PF2	Power factor, Phase 2	PF
1 or 2	PF3	Power factor, Phase 3	PF
1 or 2	DIR1	Phase difference direction, Phase 1 (0 = inductive or lag, 1 = capacitive or lead)	—
1 or 2	DIR2	Phase difference direction, Phase 2 (0 = inductive or lag, 1 = capacitive or lead)	—
1 or 2	DIR3	Phase difference direction, Phase 3 (0 = inductive or lag, 1 = capacitive or lead)	—

■ ENERGY

WORD	ID	PARAMETER	TYPE
1 or 2	EP	Active energy, incoming	EP
1 or 2	EQ	Reactive energy, LAG	EQ
1 or 2	ES	Apparent energy	ES
1 or 2	EP-	Active energy, outgoing	EP
1 or 2	EQ-	Reactive energy, LEAD	EQ
1 or 2	EQ+LAG	Reactive energy, incoming, LAG	EQ
1 or 2	EQ+LEAD	Reactive energy, incoming, LEAD	EQ
1 or 2	EQ-LAG	Reactive energy, outgoing, LAG	EQ
1 or 2	EQ-LEAD	Reactive energy, outgoing, LEAD	EQ
1 or 2	TIMER	Energy count time	C

■ AVERAGE VALUE

WORD	ID	PARAMETER	TYPE
1 or 2	I AVG	Current AVG	I
1 or 2	I1 AVG	Current AVG, Line 1	I
1 or 2	I2 AVG	Current AVG, Line 2	I
1 or 2	I3 AVG	Current AVG, Line 3	I
1 or 2	IN AVG	Neutral current AVG	I
1 or 2	I AVG 1	Current AVG, History 1	I
1 or 2	I1 AVG 1	Current AVG, Line 1, History 1	I
1 or 2	I2 AVG 1	Current AVG, Line 2, History 1	I
1 or 2	I3 AVG 1	Current AVG, Line 3, History 1	I
1 or 2	IN AVG 1	Neutral current AVG, History 1	I
1 or 2	I AVG 2	Current AVG, History 2	I
1 or 2	I1 AVG 2	Current AVG, Line 1, History 2	I
1 or 2	I2 AVG 2	Current AVG, Line 2, History 2	I
1 or 2	I3 AVG 2	Current AVG, Line 3, History 2	I
1 or 2	IN AVG 2	Neutral current AVG, History 2	I
1 or 2	I AVG 3	Current AVG, History 3	I
1 or 2	I1 AVG 3	Current AVG, Line 1, History 3	I
1 or 2	I2 AVG 3	Current AVG, Line 2, History 3	I
1 or 2	I3 AVG 3	Current AVG, Line 3, History 3	I
1 or 2	IN AVG 3	Neutral current AVG, History 3	I
1 or 2	I AVG 4	Current AVG, History 4	I

WORD	ID	PARAMETER	TYPE
1 or 2	I1 AVG 4	Current AVG, Line 1, History 4	I
1 or 2	I2 AVG 4	Current AVG, Line 2, History 4	I
1 or 2	I3 AVG 4	Current AVG, Line 3, History 4	I
1 or 2	IN AVG 4	Neutral current AVG, History 4	I
1 or 2	P AVG	Active power AVG	P
1 or 2	Q AVG	Reactive power AVG	Q
1 or 2	S AVG	Apparent power AVG	S
1 or 2	P AVG 1	Active power AVG, History 1	P
1 or 2	Q AVG 1	Reactive power AVG, History 1	Q
1 or 2	S AVG 1	Apparent power AVG, History 1	S
1 or 2	P AVG 2	Active power AVG, History 2	P
1 or 2	Q AVG 2	Reactive power AVG, History 2	Q
1 or 2	S AVG 2	Apparent power AVG, History 2	S
1 or 2	P AVG 3	Active power AVG, History 3	P
1 or 2	Q AVG 3	Reactive power AVG, History 3	Q
1 or 2	S AVG 3	Apparent power AVG, History 3	S
1 or 2	P AVG 4	Active power AVG, History 4	P
1 or 2	Q AVG 4	Reactive power AVG, History 4	Q
1 or 2	S AVG 4	Apparent power AVG, History 4	S

■ MAXIMUM / MINIMUM VALUE

WORD	ID	PARAMETER	TYPE
1 or 2	I MAX	Current MAX	I
1 or 2	U MAX	Voltage MAX	U
1 or 2	P MAX	Active power MAX	P
1 or 22	Q MAX	Reactive power MAX	Q
1 or 2	S MAX	Apparent power MAX	S
1 or 2	PF MAX	Power factor MAX	PF
1 or 2	F MAX	Frequency MAX	F
1 or 2	I1 MAX	Current MAX, Line 1	I
1 or 2	I2 MAX	Current MAX, Line 2	I
1 or 2	I3 MAX	Current MAX, Line 3	I
1 or 2	IN MAX	Neutral current MAX	I
1 or 2	U12 MAX	Delta voltage MAX, 1 – 2	U
1 or 2	U23 MAX	Delta voltage MAX, 2 – 3	U
1 or 2	U31 MAX	Delta voltage MAX, 3 – 1	U
1 or 2	U1N MAX	Phase voltage MAX, Phase 1	U
1 or 2	U2N MAX	Phase voltage MAX, Phase 2	U
1 or 2	U3N MAX	Phase voltage MAX, Phase 3	U
1 or 2	P1 MAX	Active power MAX, Phase 1	P
1 or 2	P2 MAX	Active power MAX, Phase 2	P
1 or 2	P3 MAX	Active power MAX, Phase 3	P
1 or 2	Q1 MAX	Reactive power MAX, Phase 1	Q
1 or 2	Q2 MAX	Reactive power MAX, Phase 2	Q
1 or 2	Q3 MAX	Reactive power MAX, Phase 3	Q
1 or 2	S1 MAX	Apparent power MAX, Phase 1	S
1 or 2	S2 MAX	Apparent power MAX, Phase 2	S
1 or 2	S3 MAX	Apparent power MAX, Phase 3	S
1 or 2	PF1 MAX	Power factor MAX, Phase 1	PF
1 or 2	PF2 MAX	Power factor MAX, Phase 2	PF
1 or 2	PF3 MAX	Power factor MAX, Phase 3	PF
1 or 2	THD I1 MAX	Current total harmonic distortion MAX, Line 1	H
1 or 2	THD I2 MAX	Current total harmonic distortion MAX, Line 2	H
1 or 2	THD I3 MAX	Current total harmonic distortion MAX, Line 3	H
1 or 2	THD IN MAX	Neutral current total harmonic distortion MAX	H
1 or 2	THD U12 MAX	Delta voltage total harmonic distortion MAX, 1 – 2	H
1 or 2	THD U23 MAX	Delta voltage total harmonic distortion MAX, 2 – 3	H
1 or 2	THD U31 MAX	Delta voltage total harmonic distortion MAX, 3 – 1	H
1 or 2	THD U1N MAX	Phase voltage total harmonic distortion MAX, Phase 1	H
1 or 2	THD U2N MAX	Phase voltage total harmonic distortion MAX, Phase 2	H
1 or 2	THD U3N MAX	Phase voltage total harmonic distortion MAX, Phase 3	H
1 or 2	I MAX AVG	Current MAX AVG	I

WORD	ID	PARAMETER	TYPE
1 or 2	I1 MAX AVG	Current MAX AVG, Line 1	I
1 or 2	I2 MAX AVG	Current MAX AVG, Line 2	I
1 or 2	I3 MAX AVG	Current MAX AVG, Line 3	I
1 or 2	IN MAX AVG	Neutral current MAX AVG	I
1 or 2	P MAX AVG+	Active power MAX AVG, incoming	P
1 or 2	P MAX AVG-	Active power MAX AVG, outgoing	P
1 or 2	Q MAX AVG+	Reactive power MAX AVG, incoming	Q
1 or 2	Q MAX AVG-	Reactive power MAX AVG, outgoing	Q
1 or 2	S MAX AVG	Apparent power MAX AVG	S
1 or 2	I MIN	Current MIN	I
1 or 2	U MIN	Voltage MIN	U
1 or 2	P MIN	Active power MIN	P
1 or 2	Q MIN	Reactive power MIN	Q
1 or 2	S MIN	Apparent power MIN	S
1 or 2	PF MIN	Power factor MIN	PF
1 or 2	F MIN	Frequency MIN	F
1 or 2	I1 MIN	Current MIN, Line 1	I
1 or 2	I2 MIN	Current MIN, Line 2	I
1 or 2	I3 MIN	Current MIN, Line 3	I
1 or 2	IN MIN	Neutral current MIN	I
1 or 2	U12 MIN	Delta voltage MIN, 1 – 2	U
1 or 2	U23 MIN	Delta voltage MIN, 2 – 3	U
1 or 2	U31 MIN	Delta voltage MIN, 3 – 1	U
1 or 2	U1N MIN	Phase voltage MIN, Phase 1	U
1 or 2	U2N MIN	Phase voltage MIN, Phase 2	U
1 or 2	U3N MIN	Phase voltage MIN, Phase 3	U
1 or 2	P1 MIN	Active power MIN, Phase 1	P
1 or 2	P2 MIN	Active power MIN, Phase 2	P
1 or 2	P3 MIN	Active power MIN, Phase 3	P
1 or 2	Q1 MIN	Reactive power MIN, Phase 1	Q
1 or 2	Q2 MIN	Reactive power MIN, Phase 2	Q
1 or 2	Q3 MIN	Reactive power MIN, Phase 3	Q
1 or 2	S1 MIN	Apparent power MIN, Phase 1	S
1 or 2	S2 MIN	Apparent power MIN, Phase 2	S
1 or 2	S3 MIN	Apparent power MIN, Phase 3	S
1 or 2	PF1 MIN	Power factor MIN, Phase 1	PF
1 or 2	PF2 MIN	Power factor MIN, Phase 2	PF
1 or 2	PF3 MIN	Power factor MIN, Phase 3	PF

■ TOTAL HARMONIC DISTORTION (THD)

WORD	ID	PARAMETER	TYPE
1 or 2	THD I1	Current total harmonic distortion, Line 1	H
1 or 2	THD I2	Current total harmonic distortion, Line 2	H
1 or 2	THD I3	Current total harmonic distortion, Line 3	H
1 or 2	THD IN	Neutral current total harmonic distortion	H
1 or 2	THD U12	Delta voltage total harmonic distortion, 1 – 2	H
1 or 2	THD U23	Delta voltage total harmonic distortion, 2 – 3	H
1 or 2	THD U31	Delta voltage total harmonic distortion, 3 – 1	H
1 or 2	THD U1N	Phase voltage total harmonic distortion, Phase 1	H
1 or 2	THD U2N	Phase voltage total harmonic distortion, Phase 2	H
1 or 2	THD U3N	Phase voltage total harmonic distortion, Phase 3	H

■ HARMONIC

WORD	ID	PARAMETER	TYPE
1	HD I1 2	Current harmonic, Line 1,	2nd
1	HD I1 3	(id)	3rd
1	HD I1 4	(id)	4th
1	HD I1 5	(id)	5th
1	HD I1 6	(id)	6th
1	HD I1 7	(id)	7th
1	HD I1 8	(id)	8th
1	HD I1 9	(id)	9th
1	HD I1 10	(id)	10th
1	HD I1 11	(id)	11th
1	HD I1 12	(id)	12th
1	HD I1 13	(id)	13th
1	HD I1 14	(id)	14th
1	HD I1 15	(id)	15th
1	HD I1 16	(id)	16th
1	HD I1 17	(id)	17th
1	HD I1 18	(id)	18th
1	HD I1 19	(id)	19th
1	HD I1 20	(id)	20th
1	HD I1 21	(id)	21st
1	HD I1 22	(id)	22nd
1	HD I1 23	(id)	23rd
1	HD I1 24	(id)	24th
1	HD I1 25	(id)	25th
1	HD I1 26	(id)	26th
1	HD I1 27	(id)	27th
1	HD I1 28	(id)	28th
1	HD I1 29	(id)	29th
1	HD I1 30	(id)	30th
1	HD I1 31	(id)	31st
1	HD I2 2 : HD I2 31	Current harmonic, Line 2,	2nd : 31st
1	HD I3 2 : HD I3 31	Current harmonic, Line 3,	2nd : 31st
1	HD IN 2 : HD IN 31	Neutral current harmonic,	2nd : 31st
1	HD U12 2 : HD U12 31	Delta voltage harmonic, 1 – 2,	2nd : 31st
1	HD U23 2 HD U23 31	Delta voltage harmonic, 2 – 3,	2nd 31st
1	HD U31 2 : HD U31 31	Delta voltage harmonic, 3 – 1,	2nd : 31st
1	HD U1N 2 : HD U1N 31	Phase voltage harmonic, Phase 1,	2nd : 31st
1	HD U2N 2 : HD U2N 31	Phase voltage harmonic, Phase 2,	2nd : 31st
1	HD U3N 2 : HD U3N 31	Phase voltage harmonic, Phase 3,	2nd : 31st

I/O DATA DESCRIPTIONS

■ MEASURANDS

• 16-word Mode (standard)

Measurands and assigned word numbers are specified using the R3CON PC Configurator software.
Max. 16 words per module (slot). 1 word = 16 bits, 2 words = 32 bits

• 32-word Mode (option /D)

Measurands and assigned word numbers are specified using the R3CON PC Configurator software.
Max. 32 words by virtually assigning slot (n) and (n+1) per module. 1 word = 16 bits, 2 words = 32 bits
Be sure to use the R3-BSW base with free address setting capability. DO NOT assign the module address (n+1) to any module.
A duplicate address will cause malfunctions.

■ ASSIGNING 32-BIT DATA FORMAT

When 2 word data is assigned to start address of analog input, the address is the example shown below.

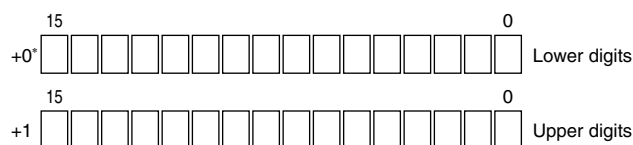

* +0 shown above refers the start address of analog input. +1 refers the start address added by 1.

■ RESET

Assign each reset item to start address of analog input. Set '1' to the assigned bits for the measurands to be reset, and set '0' again after the resetting is confirmed.

The resetting is executed at the moment when the signal rises from 0 to 1.

