

AC POWER INPUT MODULE
(4 input circuits)MODEL **R3-WT4****BEFORE USE**

Thank you for choosing M-System. Before use, please check contents of the package you received as outlined below.

If you have any problems or questions with the product, please contact M-System's Sales Office or representatives.

■ PACKAGE INCLUDES:

AC power input module(1)

■ MODEL NO.

Confirm Model No. marking on the product to be exactly what you ordered.

■ INSTRUCTION MANUAL

This manual describes necessary points of caution when you use this product, including installation, connection and basic maintenance procedures.

In order to set up the software setting of this module, PC Configurator Software (model: R3CON) is required. For more information, please refer to the users manual for the R3CON.

The R3CON PC Configurator Software is downloadable at M-System's web site: <http://www.m-system.co.jp>.

POINTS OF CAUTION**■ HOT SWAPPABLE MODULES**

- Replacing the module does not affect other modules on the same base. Thus, the module can be replaced while the power is ON. However, replacing multiple modules at once may greatly change live voltage levels. We highly recommend to replace them one by one.

■ GENERAL PRECAUTIONS

- DO NOT set the switches on the module while the power is supplied. The switches are used only for maintenance without the power.

■ ENVIRONMENT

- Indoor use.
- When heavy dust or metal particles are present in the air, install the unit inside proper housing with sufficient ventilation.
- Do not install the unit where it is subjected to continuous vibration. Do not subject the unit to physical impact.
- Environmental temperature must be within -10 to +55°C (14 to 131°F) with relative humidity within 30 to 90% RH in order to ensure adequate life span and operation.

■ WIRING

- Do not install cables close to noise sources (relay drive cable, high frequency line, etc.).
- Do not bind these cables together with those in which noises are present. Do not install them in the same duct.

■ AND

- The unit is designed to function as soon as power is supplied, however, a warm up for 10 minutes is required for satisfying complete performance described in the data sheet.

INSTALLATION

Use the Installation Base (model: R3-BSx).

COMPONENT IDENTIFICATION

FRONT VIEW

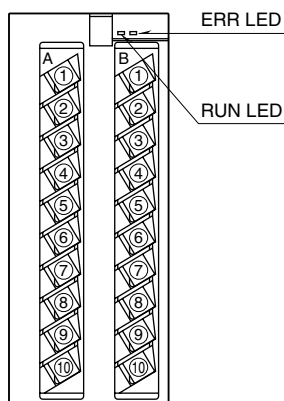

SIDE VIEW

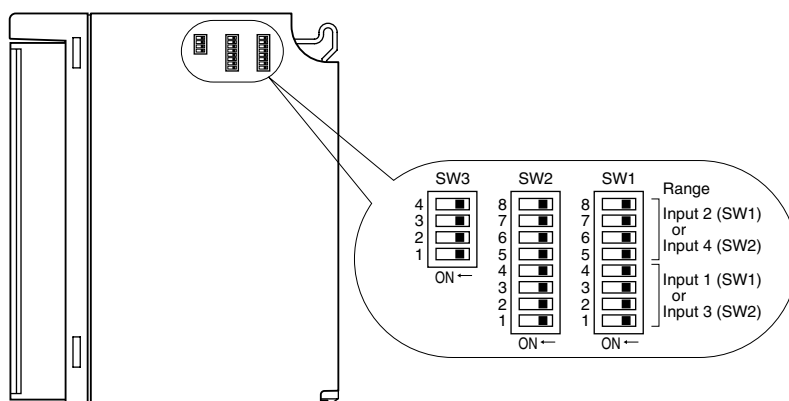

STATUS INDICATOR LED

- RUN indicator:** Bi-color (red/green) LED;
 Red when the bus A operates normally;
 Green when the bus B operates normally;
 Amber when both buses operate normally.
- ERR indicator:** Bi-color (red/green) LED;
 Red with input abnormality;
 Green in normal operating conditions.

SIDE DIP SW

(*) Factory setting

Measuring variables, computation methods can be specified using the side DIP SW. Be sure to turn off the power supply to the module when changing settings. Reset the count after setting changes.

SW1, SW2

Count Reset Disable: Halt at 10^4 or 10^9 at overflow
 Enable: Back to 1 at overflow

SW	CH	FUNCTION	0: OFF (*)	1: ON
SW1-2	1	Count reset	Disable	Enable
SW1-3	1	Bidirectional current	Disable	Enable
SW1-6	2	Count reset	Disable	Enable
SW1-7	2	Bidirectional current	Disable	Enable
SW2-2	3	Count reset	Disable	Enable
SW2-3	3	Bidirectional current	Disable	Enable
SW2-6	4	Count reset	Disable	Enable
SW2-7	4	Bidirectional current	Disable	Enable

SW3

The maximum available active energy count is 10^4 with 16 bits, 10^9 with 32 bits.

SW	0: OFF (*)	1: ON
SW3-1	----	Count reset

All count values are reset to 0.

How to Reset

Set the SW3-1 to ON and turn on the power supply. Wait until the RUN LED (red) starts blinking and the ERR LED (green) turns on. Then turn the power supply off and reset the SW3-1 to OFF.

SW3-3	SW3-4	VARIABLE A	VARIABLE B	VARIABLE C
OFF (*)	OFF (*)	Active power 16 bits	Incoming energy 16 bits	Outgoing energy 16 bits
ON	OFF	Active power 16 bits	Incoming energy 32 bits	----
OFF	ON	Incoming energy 16 bits	Outgoing energy 16 bits	----
ON	ON	Incoming energy 32 bits	Outgoing energy 32 bits	----

The outgoing energy becomes 0 when the bidirectional current computation is enabled.

Note: Be sure to set unused SW1-1, 1-4, 1-5, 1-8, SW2-1, 2-4, 2-5, 2-8 and SW3-2 to OFF.

PC CONFIGURATOR

With configurator software, settings shown below are available.
Refer to the software manual of R3CON for detailed operation.

■ CHANNEL INDIVIDUAL SETTING

PARAMETER	AVAILABLE RANGE	DEFAULT SETTING
Adjust Bias	-320.00 to +320.00	0.00
Adjust Gain	-32000 to +32000	1.0000
CT (A) PRI	1 to 100	Input codes 1, 4, B: 5 Input codes 2, 3, A: 1
CT (A) U	0 to 126	0
WFS	0 (Automatically calculated with VT and CT values), 1 to 10000	0
WU	-126 to 126 (Automatically calculated with VT and CT values if set to 0)	0
WhU	-3 to 4	2*1

*1. 3 in case of R3-WT411, R3-WT414, R3-WT424 and R3-WT43B

■ CHANNEL BATCH SETTING

PARAMETER	AVAILABLE RANGE	DEFAULT SETTING
Drop-Out	0.00 to 10.00 (%)	2.00 (%)
VT (V) PRI	1 to 10000	Input codes 1, 2: 110 Input codes 3, 4: 220 Input codes A, B: 200
VT (V) U	0 to 126	0

TRANSMISSION DATA DESCRIPTIONS

ADDRESS	VARIABLE A	Active power 16 bits	Active power 16 bits	Incoming energy 16 bits	Incoming energy 32 bits
	VARIABLE B	Incoming energy 16 bits	Incoming energy 32 bits	Outgoing energy 16 bits	Outgoing energy 32 bits
	VARIABLE C	Outgoing energy 16 bits	----	----	----
n		Active power ch. 1	Active power ch. 1	Incoming energy ch. 1	Incoming energy ch. 1, lower digits
n + 1		Active power ch. 2	Active power ch. 2	Incoming energy ch. 2	Incoming energy ch. 1, upper digits
n + 2		Active power ch. 3	Active power ch. 3	Incoming energy ch. 3	Incoming energy ch. 2, lower digits
n + 3		Active power ch. 4	Active power ch. 4	Incoming energy ch. 4	Incoming energy ch. 2, upper digits
n + 4		Incoming energy ch. 1	Incoming energy ch. 1, lower digits	Outgoing energy ch. 1	Incoming energy ch. 3, lower digits
n + 5		Incoming energy ch. 2	Incoming energy ch. 1, upper digits	Outgoing energy ch. 2	Incoming energy ch. 3, upper digits
n + 6		Incoming energy ch. 3	Incoming energy ch. 2, lower digits	Outgoing energy ch. 3	Incoming energy ch. 4, lower digits
n + 7		Incoming energy ch. 4	Incoming energy ch. 2, upper digits	Outgoing energy ch. 4	Incoming energy ch. 4, upper digits
n + 8		Outgoing energy ch. 1	Incoming energy ch. 3, lower digits	0	Outgoing energy ch. 1, lower digits
n + 9		Outgoing energy ch. 2	Incoming energy ch. 3, upper digits	0	Outgoing energy ch. 1, upper digits
n + 10		Outgoing energy ch. 3	Incoming energy ch. 4, lower digits	0	Outgoing energy ch. 2, lower digits
n + 11		Outgoing energy ch. 4	Incoming energy ch. 4, upper digits	0	Outgoing energy ch. 2, upper digits
n + 12		0	0	0	Outgoing energy ch. 3, lower digits
n + 13		0	0	0	Outgoing energy ch. 3, upper digits
n + 14		0	0	0	Outgoing energy ch. 4, lower digits
n + 15		0	0	0	Outgoing energy ch. 4, upper digits
SW3-3 / SW3-4 setting		OFF / OFF	ON / OFF	OFF / ON	ON / ON
R3CON type ID		WT4****0	WT4****1	WT4****2	WT4****3
Network Module Data Allocation Mode*1		4, 8, 16	4, 8, 16	4, 8	4, 8, 16

n = I/O address on the installation base

Factory setting = 1 kWh per bit.

Data address depends upon the data allocation mode as indicated below:

4 (n thr. n +3)

8 (n thr. n +7)

16 (n thr. n + 15)

*1. Fixed at 16 for the R3-NPx.

I/O DATA DESCRIPTIONS

■ 16-BIT DATA

16-bit binary data. Minus values are represented in 2's complements.

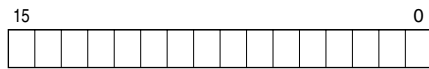

■ 32-BIT DATA

32-bit binary data. Minus values are represented in 2's complements.

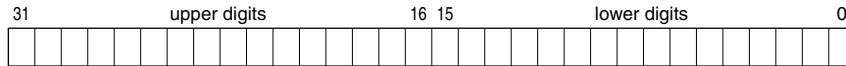

TERMINAL CONNECTIONS

Connect the unit as in the diagram below.

■ EXTERNAL DIMENSIONS unit: mm (inch)

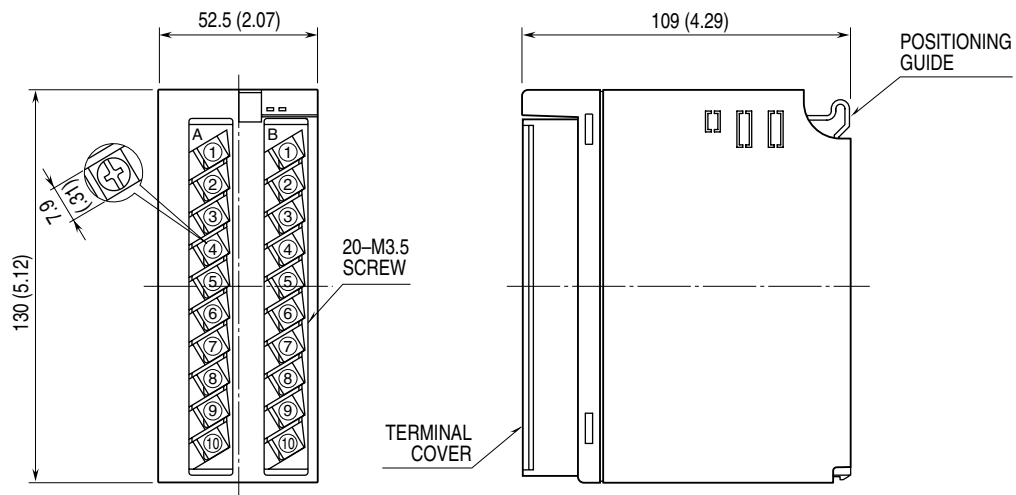

■ CONNECTION DIAGRAM

■ 3-PHASE/3-WIRE

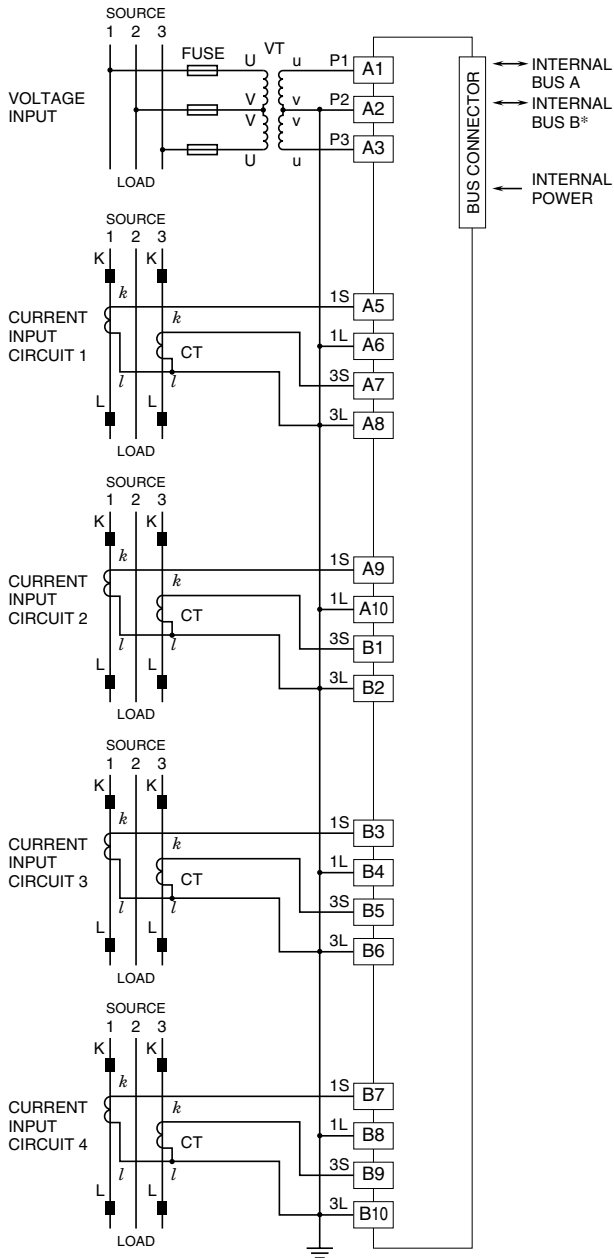

*For dual redundant communication.

■ SINGLE-PHASE/2-WIRE

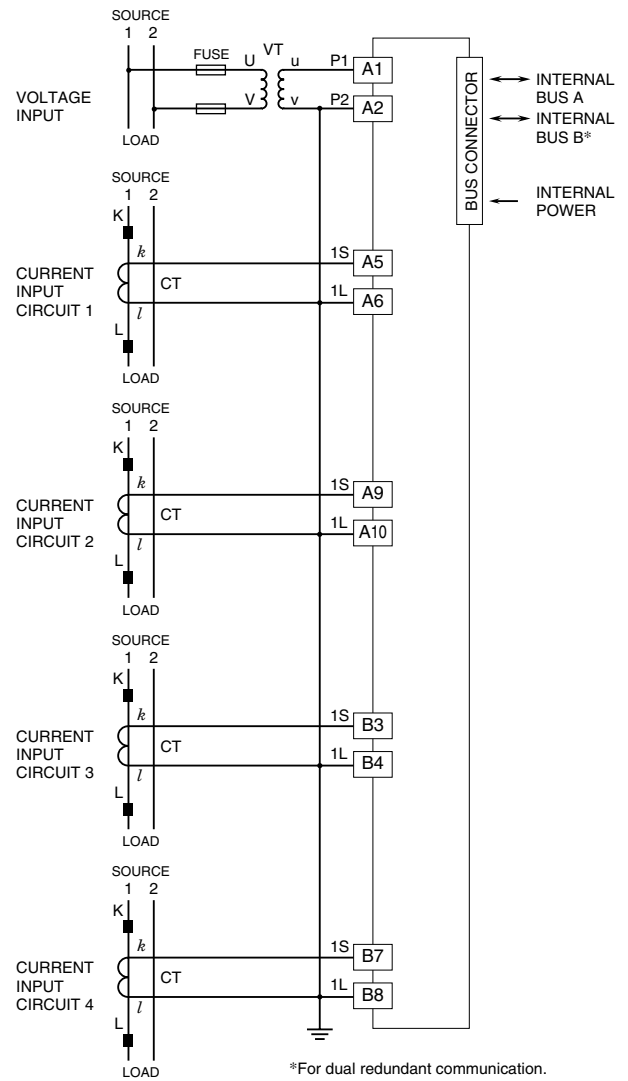

*For dual redundant communication.

■ SINGLE-PHASE/3-WIRE

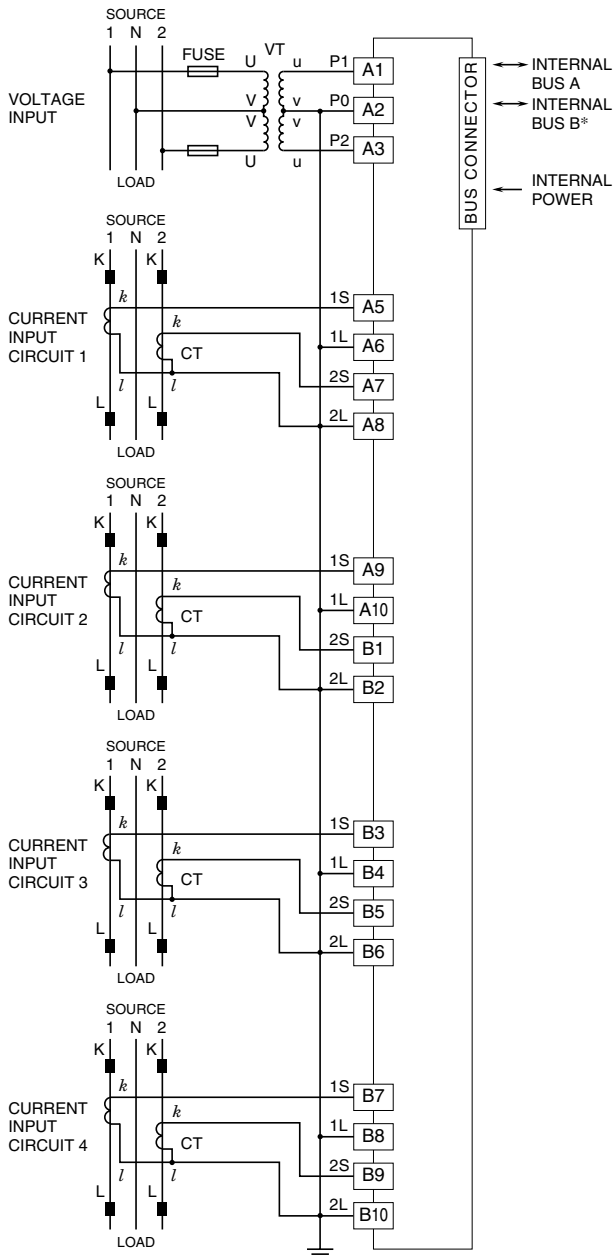

*For dual redundant communication.

WIRING INSTRUCTIONS

■ SCREW TERMINAL

Torque: 0.8 N·m

■ SOLDERLESS TERMINAL unit: mm (inch)

Refer to the drawing below for recommended ring tongue terminal size. Spade tongue type is also applicable. Solderless terminals with insulation sleeve do not fit.

Applicable wire size: 1.04 – 2 mm²

Recommended manufacturer: Japan Solderless Terminal MFG. Co., Ltd., Nichifu Co., Ltd.

