

MULTI POWER INPUT MODULE
(clamp-on current sensor type CLSA use)MODEL **R3-WT1A****BEFORE USE**

Thank you for choosing M-System. Before use, please check contents of the package you received as outlined below.

If you have any problems or questions with the product, please contact M-System's Sales Office or representatives.

■ PACKAGE INCLUDES:

Multi power input module(1)

■ MODEL NO.

Confirm Model No. marking on the product to be exactly what you ordered.

■ INSTRUCTION MANUAL

This manual describes necessary points of caution when you use this product, including installation, connection and basic maintenance procedures.

In order to set up the software setting of this module, PC Configurator Software (model: R3CON) is required. For more information, please refer to the users manual for the R3CON.

The R3CON PC Configurator Software is downloadable at M-System's web site: <http://www.m-system.co.jp>.

POINTS OF CAUTION**■ HOT SWAPPABLE MODULES**

- Replacing the module does not affect other modules on the same base. Thus, the module can be replaced while the power is ON. However, replacing multiple modules at once may greatly change live voltage levels. We highly recommend to replace them one by one.

■ GENERAL PRECAUTIONS

- DO NOT set the switches on the module while the power is supplied. The switches are used only for maintenance without the power.

■ ENVIRONMENT

- Indoor use.
- When heavy dust or metal particles are present in the air, install the unit inside proper housing with sufficient ventilation.
- Do not install the unit where it is subjected to continuous vibration. Do not subject the unit to physical impact.
- Environmental temperature must be within -10 to +55°C (14 to 131°F) with relative humidity within 30 to 90% RH in order to ensure adequate life span and operation.

■ WIRING

- Do not install cables close to noise sources (relay drive cable, high frequency line, etc.).
- Do not bind these cables together with those in which noises are present. Do not install them in the same duct.

■ AND

- The unit is designed to function as soon as power is supplied, however, a warm up for 10 minutes is required for satisfying complete performance described in the data sheet.

INSTALLATION

Use the Installation Base (model: R3-BSx).

COMPONENT IDENTIFICATION

FRONT VIEW

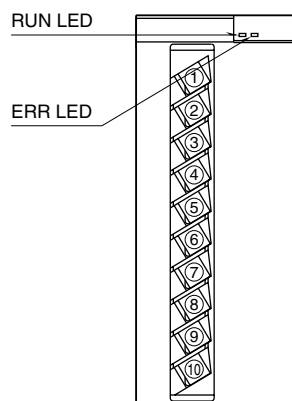

SIDE VIEW

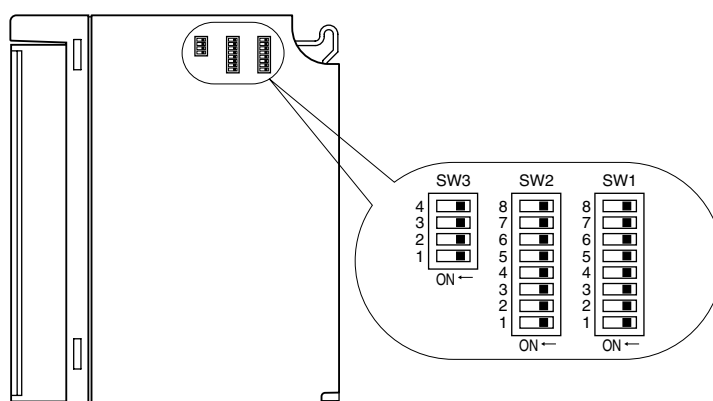

STATUS INDICATOR LED

- RUN indicator:** Bi-color (red/green) LED;
 Red when the bus A operates normally;
 Green when the bus B operates normally;
 Amber when both buses operate normally.
- ERR indicator:** Bi-color (red/green) LED;
 Red with input abnormality;
 Green in normal operating conditions.

SIDE DIP SW

(*) Factory setting

Be sure to turn off the power supply to the module when changing settings. Reset the count after setting changes.

SW1, SW2

Count Reset Enable: Back to 0 at overflow

Disable: Halt at 999 999 999

Power Factor may start hunting around 1.

SW	FUNCTION	0: OFF (*)	1: ON
SW1-2	Active energy count reset	Disable	Enable
SW1-3	Active energy bidirectional current	Disable	Enable* ¹
SW1-6	Active energy count reset	Disable	Enable
SW1-7	Active energy bidirectional current	Disable	Enable* ¹
SW2-1	Power factor LEAD polarity	Normal	Inverted

*1. Both active energy count reset and reactive energy count reset are fixed at 'disable.'

The count stops at $\pm 999\,999\,999$.

When the bidirectional current computation is enabled, the outgoing active energy and the LEAD reactive energy become 0.

Power Factor Polarity

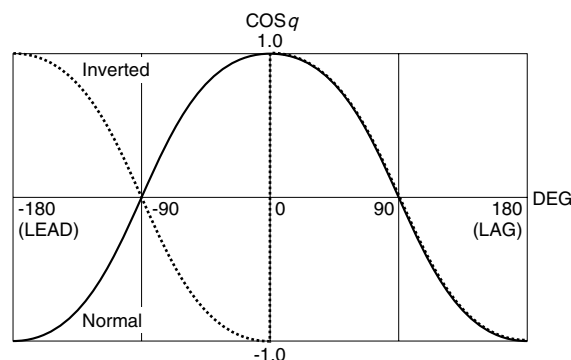

SW3

The maximum available active energy count is 10^9 .

SW	0: OFF (*)	1: ON
SW3-1	----	Count reset

How to Reset

Set the SW3-1 to ON and turn on the power supply. Wait until the RUN LED (red) starts blinking and the ERR LED (green) turns on. Then turn the power supply off and reset the SW3-1 to OFF.

Note: Be sure to set unused SW1-1, 1-4, 1-5, 1-8, SW2-2 through 2-8 and SW3-2 through 3-4 to OFF.

PC CONFIGURATOR

With configurator software, settings shown below are available.
Refer to the software manual of R3CON for detailed operation.

PARAMETER	AVAILABLE RANGE	DEFAULT SETTING
W Bias	-320.00 to +320.00	0.00
W Gain	-32000 to +32000	1.0000
var Bias	-320.00 to +320.00	0.00
var Gain	-32000 to +32000	1.0000
cos Bias	-320.00 to +320.00	0.00
cos Gain	-32000 to +32000	1.0000
Hz Bias	-320.00 to +320.00	0.00
Hz Gain	-32000 to +32000	1.0000
Drop-Out	0.00 to 10.00 (%)	2.00 (%)
VT (V) PRI	1 to 10000	Input codes 1, 2: 110 Input codes 5, 6: 220 Input codes A, B: 200
VT (V) U/T	0 to 126	0
CT (A) PRI	1 to 999	Input codes 1, 5, A: 80 Input codes 2, 6, B: 120
CT (A) U/T	1 to 99	1
W/var FS	0 (Automatically calculated with VT and CT values), 1 to 10000	0
W/var Unit	-126 to 126 (Automatically calculated with VT and CT values if set to 0)	0
Wh Unit	-3 to 4	2 ^{*1}
Wh Min.	0, 1	0
Wh Max.	1 to 1,000,000,000	1,000,000,000
varh Unit	-3 to 4	2 ^{*1}
varh Min.	0, 1	0
varh Max.	1 to 1,000,000,000	1,000,000,000

*1. 3 in case of R3-WT1A21

TRANSMISSION DATA DESCRIPTIONS

ADDRESS	CONTENTS
n	Active power ^{*2}
n + 1	Reactive power ^{*2}
n + 2	Power factor ^{*2}
n + 3	Frequency ^{*2}
n + 4	Incoming active energy (lower bits)] ^{*3}
n + 5	Incoming active energy (upper bits)]
n + 6	Outgoing active energy (lower bits)] ^{*3}
n + 7	Outgoing active energy (upper bits)]
n + 8	LAG reactive energy (lower bits)] ^{*3}
n + 9	LAG reactive energy (upper bits)]
n + 10	LEAD reactive energy (lower bits)] ^{*3}
n + 11	LEAD reactive energy (upper bits)]
n + 12	0
n + 13	0
n + 14	0
n + 15	0
R3CON type ID	WT1A ^{***}
Network module data allocation mode example ^{*1}	4, 8, 16

n = I/O address on the installation base
Factory setting = 1 kWh and 1 kvarh per bit.
Data address depends upon the data allocation mode as indicated below:

- 4 (n thr. n+3)
- 8 (n thr. n+7)
- 16 (n thr. n+15)

*1. Fixed at 16 for the R3-NPx.

*2. 16-bit data

*3. 32-bit data

I/O DATA DESCRIPTIONS

■ 16-BIT DATA

16-bit binary data. Minus values are represented in 2's complements.



■ 32-BIT DATA

32-bit binary data. Minus values are represented in 2's complements.

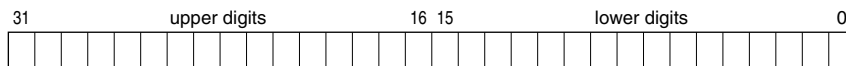

TERMINAL CONNECTIONS

Connect the unit as in the diagram below.

■ EXTERNAL DIMENSIONS unit: mm (inch)

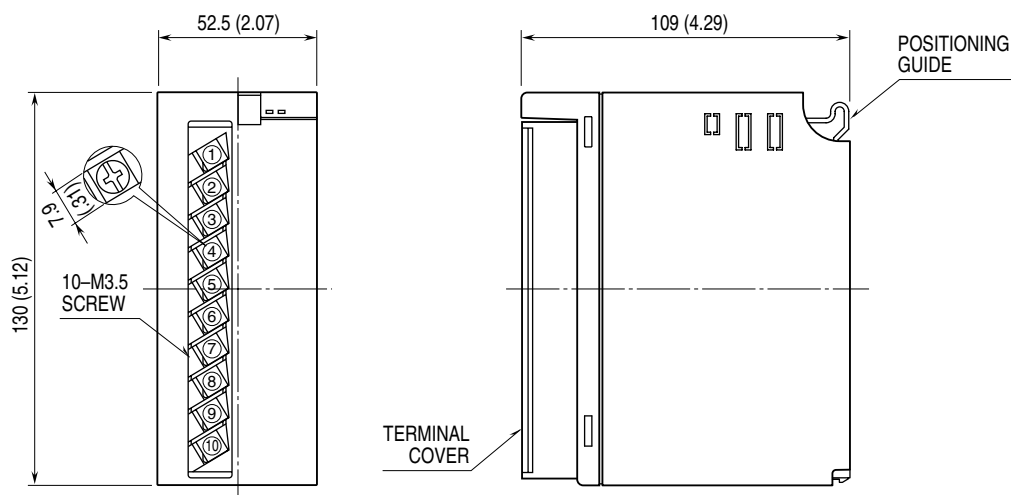

■ CONNECTION DIAGRAM

■ 3-PHASE/3-WIRE

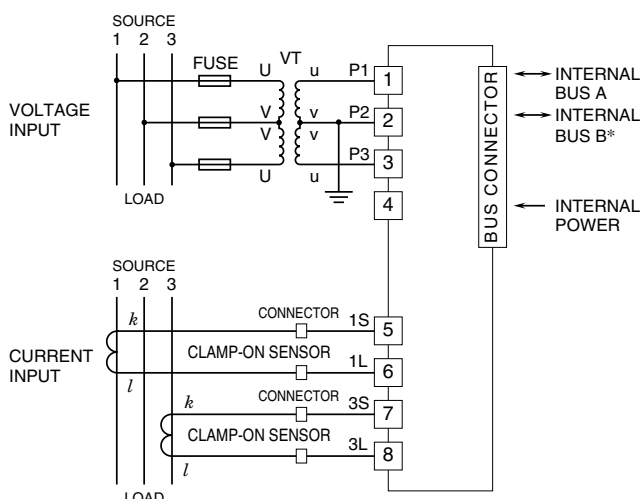

■ SINGLE-PHASE/3-WIRE

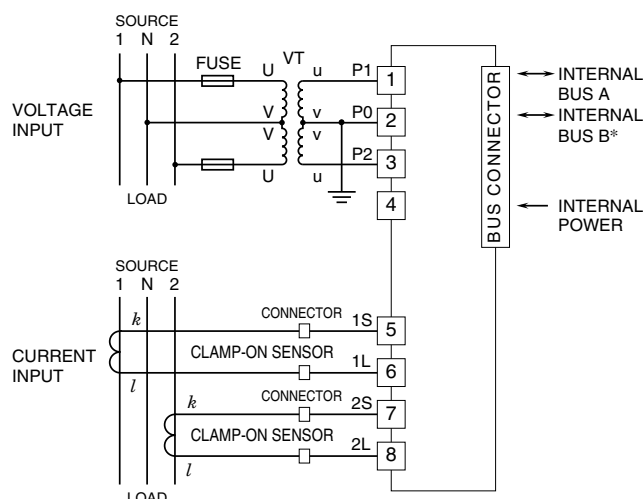

■ SINGLE-PHASE/2-WIRE

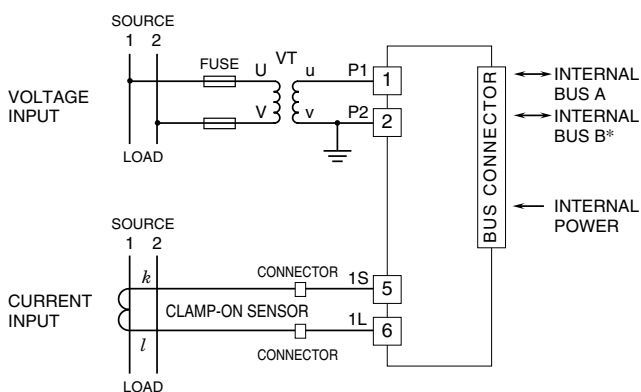

*For dual redundant communication.

WIRING INSTRUCTIONS

■ SCREW TERMINAL

Torque: 0.8 N·m

■ SOLDERLESS TERMINAL unit: mm (inch)

Refer to the drawing below for recommended ring tongue terminal size. Spade tongue type is also applicable. Solderless terminals with insulation sleeve do not fit.

Applicable wire size: 0.3 – 0.75 mm²

Recommended manufacturer: Japan Solderless Terminal MFG. Co., Ltd., Nichifu Co., Ltd.

