

**UNIVERSAL INPUT MODULE**  
(4 points, isolated)

MODEL **R3-US4**

**BEFORE USE ....**

Thank you for choosing M-System. Before use, please check contents of the package you received as outlined below. If you have any problems or questions with the product, please contact M-System's Sales Office or representatives.

**■ PACKAGE INCLUDES:**

Universal input module (body + 4 CJC sensors).....(1)

**■ MODEL NO.**

Confirm Model No. marking on the product to be exactly what you ordered.

**■ INSTRUCTION MANUAL**

This manual describes necessary points of caution when you use this product, including installation, connection and basic maintenance procedures.

In order to set up the software setting of this module, PC Configurator Software (model: R3CON) is required. For more information, please refer to the users manual for the R3CON.

The R3CON PC Configurator Software is downloadable at M-System's web site: <http://www.m-system.co.jp>.

**POINTS OF CAUTION**

**■ HOT SWAPPABLE MODULES**

- Replacing the module does not affect other modules on the same base. Thus, the module can be replaced while the power is ON. However, replacing multiple modules at once may greatly change live voltage levels. We highly recommend to replace them one by one.

**■ ENVIRONMENT**

- Indoor use.
- When heavy dust or metal particles are present in the air, install the unit inside proper housing with sufficient ventilation.
- Do not install the unit where it is subjected to continuous vibration. Do not subject the unit to physical impact.
- Environmental temperature must be within -10 to +55°C (14 to 131°F) with relative humidity within 30 to 90% RH in order to ensure adequate life span and operation.

**■ WIRING**

- Do not install cables close to noise sources (relay drive cable, high frequency line, etc.).
- Do not bind these cables together with those in which noises are present. Do not install them in the same duct.

**■ UNUSED INPUT CHANNELS**

- Setting the unused channels as "Unused" with the configurator software (model: R3CON) prevents the error due to open circuit.

**■ AND ....**

- The unit is designed to function as soon as power is supplied, however, a warm up for 10 minutes is required for satisfying complete performance described in the data sheet.

**INSTALLATION**

Use the Installation Base (model: R3-BSx).

**COMPONENT IDENTIFICATION**

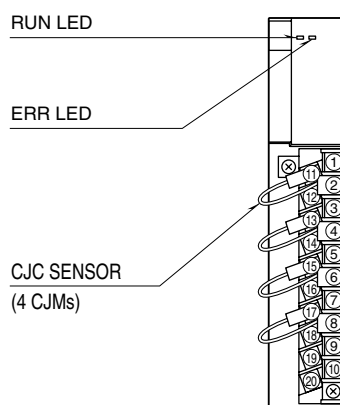

**■ STATUS INDICATOR LED**

- RUN indicator:** Bi-color (red/green) LED;  
 Red when the bus A operates normally;  
 Green when the bus B operates normally;  
 Amber when both buses operate normally.
- ERR indicator:** Bi-color (red/green) LED;  
 Red with burnout;  
 Green in normal operating conditions.

## PC CONFIGURATOR

With configurator software, settings shown below are available.  
Refer to the software manual of R3CON for detailed operation.

### ■ CHANNEL INDIVIDUAL SETTING

PARAMETER	AVAILABLE RANGE	DEFAULT SETTING
Input Type	-60 to 60mV -125 to 125mV -250 to 250mV -500 to 500mV -1000 to 1000mV -3 to 3V -6 to 6V -12 to 12V (PR) *1 K (CA) E (CRC) J (IC) T (CC) B (RH) *1 R *1 S *1 C (WRe 5-26) *1 N *1 U *1 L *1 P (Platinel II) *1 Pt 100 (JIS '89) Pt 100 (JIS '97, IEC) Pt 1000 *1 Pt 50 Ω (JIS '81) JPt 100 (JIS '89) Ni 100 *1 Ni 120 *1 Ni 508.4 Ω *1 Cu 50 *1 POT 200 POT 500 POT 5k	-12 to 12V
Zero Scale	-32000 to +32000	0
Full Scale	-32000 to +32000	10000
Zero Adjust	-320.00 to +320.00	0.00
Full Adjust	-32000 to +32000	1.0000
Zero Base	Depends on input type	0.00
Full Base	Depends on input type	0.00
Burnout	None, Up, Down	None
CJC SW	No check mark: Disable Check-marked: Enable	Check-marked: Enable
Unused	0: Enable 1: Disable	0: Enable

### ■ CHANNEL BATCH SETTING

PARAMETER	AVAILABLE RANGE	DEFAULT SETTING
Unit	C, F, K *1	C
ADC Speed	Middle *2, Low	Middle
Limit	No check mark: Limits to the scaling values equivalent to -10 % to +110 %. Check-marked: Limits within Zero Scale to Full Scale.	No check mark

\*1. Not selectable with the R3-US4x/A.

\*2. Fixed at Low for the R3-US4x/A.

# TERMINAL CONNECTIONS

Connect the unit as in the diagram below.

## EXTERNAL DIMENSIONS unit: mm (inch)

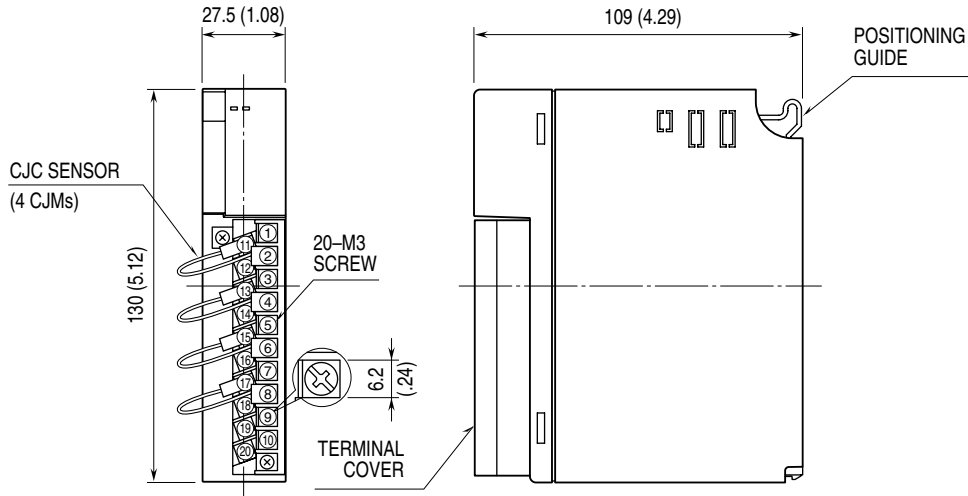

## CONNECTION DIAGRAM

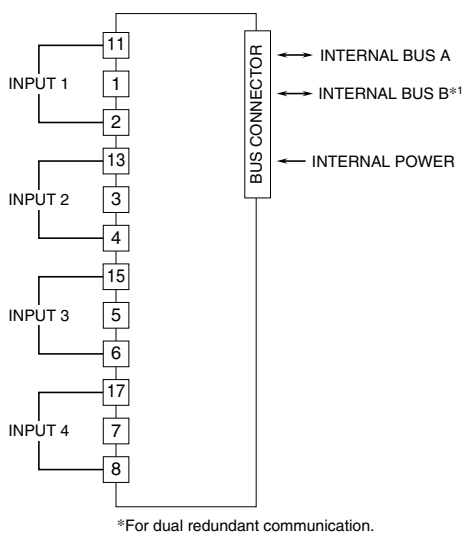

### INPUT CONNECTION

#### DC VOLTAGE

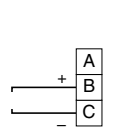

#### THEMOCOUPLE

- Upscale/no burnout

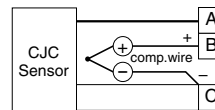

- Downscale burnout

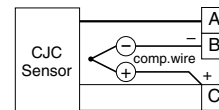

#### RTD

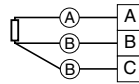

#### POTENTIOMETER

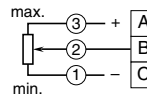

#### TERMINAL NETWORK

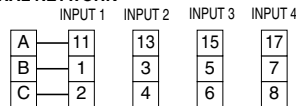

Note 1: Remove CJC sensor for RTD or potentiometer input. The CJC sensor does not affect to DC voltage input.

Note 2: Be sure to eliminate noise as much as possible by e.g. using shielded cables. Ground the signal shield to a most stable earth point in the environment.

Note 3: The temperature imbalance around the terminal affects greatly the cold junction compensation accuracy.

In order to minimize such imbalance, do not expose the input terminals directly to the wind from a cooling fan.

## INPUT DATA DESCRIPTIONS

### ■ UNIVERSAL INPUT DATA (SCALING CONVERSION DATA)

16-bit binary data.

When scaling setting is initial value, 0 to 10000, data is 0 to 10000 for input 0 to 100% setting.

Input range is -10 to +110% (-1000 to +11000). When out of input range, it is fixed to -1000 or 11000.

Minus value is converted into negative values, represented in 2's complements.

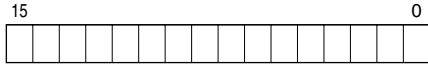

### ■ UNIVERSAL INPUT DATA (TEMPERATURE DATA)

16-bit binary data.

- Temperature input accuracy is 'Standard'

With °C temperature unit or K temperature unit, raw data is multiplied by 10. For example, 25.5°C is converted into 255.

With °F temperature unit, the integer section of raw data is directly converted into the data. For example, 135.4°F is converted into 135.

Minus temperature is converted into negative values, represented in 2's complements.

- Temperature input accuracy is 'High accuracy (Option code /A)'

With °C temperature unit, raw data is multiplied by 100. For example, 25.5°C is converted into 2550.

With °F temperature unit, raw data is multiplied by 10. For example, 135.4°F is converted into 1354.

Minus temperature is converted into negative values, represented in 2's complements.



## WIRING INSTRUCTIONS

### ■ SCREW TERMINAL

Torque: 0.5 N·m

### ■ SOLDERLESS TERMINAL

Refer to the drawing below for recommended ring tongue terminal size. Spade tongue type is also applicable. Solderless terminals with insulation sleeve do not fit.

Applicable wire size: 0.3 – 0.75 mm<sup>2</sup>

Recommended manufacturer: Japan Solderless Terminal MFG. Co., Ltd., Nichifu Co., Ltd.

