

DC VOLTAGE INPUT MODULE
(8 points, non-isolated, tension clamp terminal block)MODEL **R3S-SV8N****BEFORE USE**

Thank you for choosing M-System. Before use, please check contents of the package you received as outlined below.

If you have any problems or questions with the product, please contact M-System's Sales Office or representatives.

■ PACKAGE INCLUDES:

DC voltage input module.....(1)

■ MODEL NO.

Confirm Model No. marking on the product to be exactly what you ordered.

■ INSTRUCTION MANUAL

This manual describes necessary points of caution when you use this product, including installation, connection and basic maintenance procedures.

POINTS OF CAUTION**■ HOT SWAPPABLE MODULES**

- Replacing the module does not affect other modules on the same base. Thus, the module can be replaced while the power is ON. However, replacing multiple modules at once may greatly change live voltage levels. We highly recommend to replace them one by one.

■ GENERAL PRECAUTIONS

- DO NOT set the switches on the module while the power is supplied. The switches are used only for maintenance without the power.

■ ENVIRONMENT

- Indoor use.
- When heavy dust or metal particles are present in the air, install the unit inside proper housing with sufficient ventilation.
- Do not install the unit where it is subjected to continuous vibration. Do not subject the unit to physical impact.
- Environmental temperature must be within -10 to +55°C (14 to 131°F) with relative humidity within 30 to 90% RH in order to ensure adequate life span and operation.

■ WIRING

- Do not install cables close to noise sources (relay drive cable, high frequency line, etc.).
- Do not bind these cables together with those in which noises are present. Do not install them in the same duct.

■ UNUSED INPUT CHANNELS

- Set the unused channels to "Unused" with PC Configurator software: R3CON. For 1 – 5 V DC, unused channels left open with other settings may be equal to the input lower than -15 %, which sets a data abnormality at the PLC or the host device.

■ AND

- The unit is designed to function as soon as power is supplied, however, a warm up for 10 minutes is required for satisfying complete performance described in the data sheet.

INSTALLATION

Use the Installation Base (model: R3-BSx).

COMPONENT IDENTIFICATION

FRONT VIEW

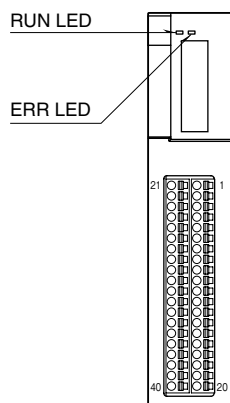

SIDE VIEW

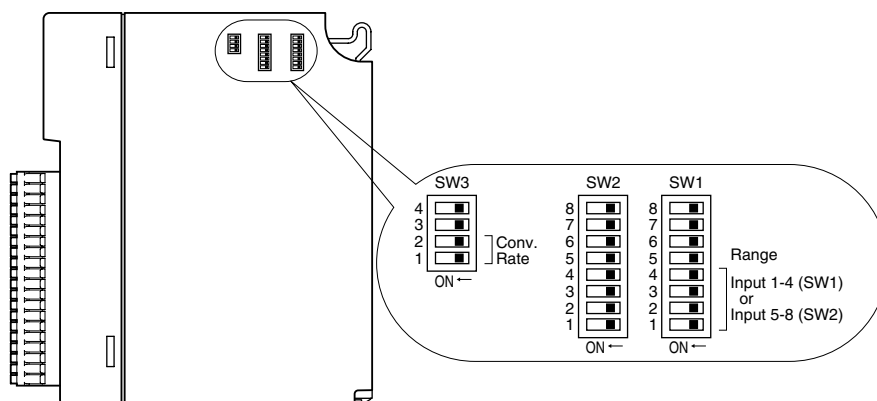

STATUS INDICATOR LED

RUN indicator: Bi-color (red/green) LED;

Red when the bus A operates normally;
Green when the bus B operates normally;
Amber when both buses operate normally.

ERR indicator: Bi-color (red/green) LED;

Red with input circuit abnormality (AD converter response failure);
Green in normal operating conditions.

SIDE DIP SW

(*) Factory setting

• Input Range: SW1, SW2 (selectable per 4 channels)

INPUT 1 through INPUT 4 (SW1)				RANGE
INPUT 5 through INPUT 8 (SW2)				
1	2	3	4	
OFF	OFF	OFF	OFF	-10 – +10V (*)
ON	OFF	OFF	OFF	-5 – +5V
ON	ON	OFF	OFF	0 – 10V
OFF	OFF	ON	OFF	0 – 5V
ON	OFF	ON	OFF	1 – 5V

• Conversion Rate: SW3-1, 3-2

SW	CONVERSION RATE			
	100 ms (*)	50 ms	20 ms	10 ms
SW3-1	OFF	ON	OFF	ON
SW3-2	OFF	OFF	ON	ON

Note: Be sure to set unused SW1-5 through 1-8, SW2-5 through 2-8, SW3-3 and 3-4 to OFF.

PC CONFIGURATOR

With configurator software, settings shown below are available.
Refer to the software manual of R3CON for detailed operation.

CHANNEL INDIVIDUAL SETTING

PARAMETER	AVAILABLE RANGE	DEFAULT SETTING
Zero Scale	-32000 to +32000	0
Full Scale	-32000 to +32000	10000
Zero Adjust	-320.00 to +320.00	0.00
Full Adjust	-32000 to +32000	1.0000
Unused	0: Enable 1: Disable	0: Enable

TERMINAL CONNECTIONS

Connect the unit as in the diagram below.

■ EXTERNAL DIMENSIONS unit: mm (inch)

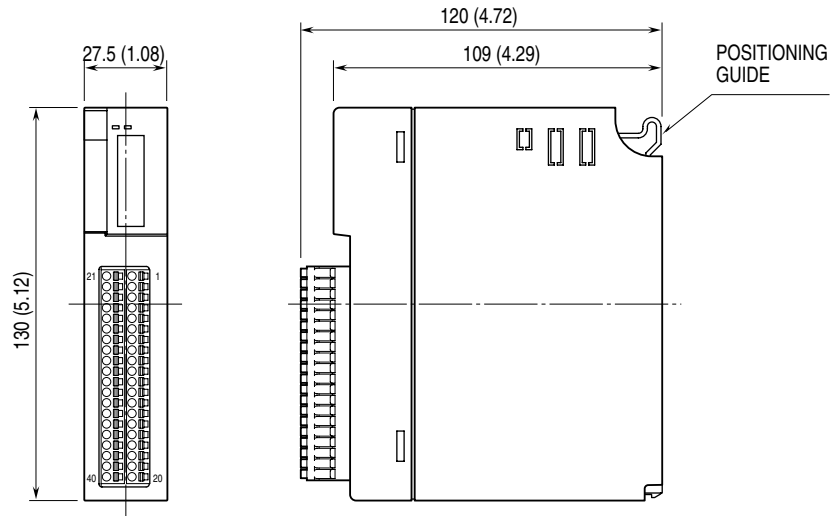

CONNECTION DIAGRAM

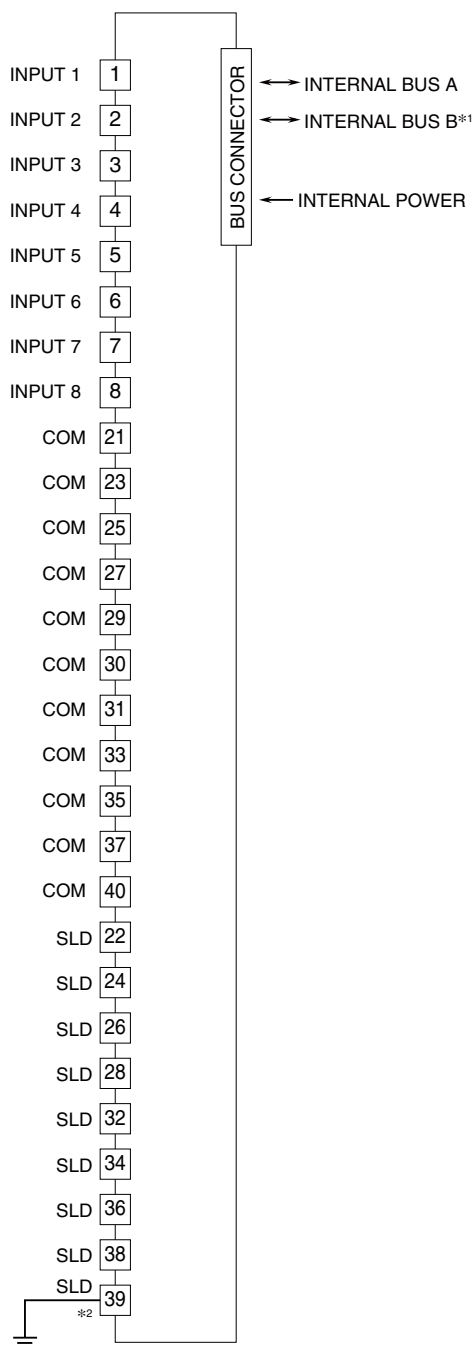

*1. For dual redundant communication.

*2. To use shield line, connect it to SLD terminal and ground the terminal 39.

Note: Do not use void terminals.

WIRING INSTRUCTIONS

APPLICABLE WIRE SIZE

- **Solid:** 0.2 to 1.0 mm² (0.55 to 1.12 dia.)
- **Stranded:** 0.2 to 1.5 mm²

(Tinning wire ends may cause contact failure and therefore is not recommended.)

Feruled:

Unsheathed: 0.25 to 1.5 mm²

Sheathed: 0.25 to 0.75 mm²

- Expose wire conductors by 10 mm (0.39").

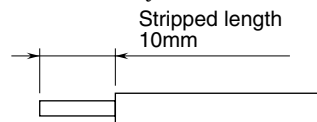

CONNECTION PROCEDURE

Insert the wire end until it comes to a full stop while pushing slot with the tip of a screw driver as shown below. Be sure wire insulation is not inside the terminal.

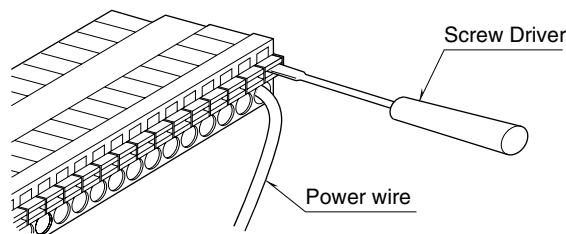

INPUT PIN ASSIGNMENT

PIN No.	FUNCTION	PIN No.	FUNCTION
21	COM	1	V1
22	SLD	2	V2
23	COM	3	V3
24	SLD	4	V4
25	COM	5	V5
26	SLD	6	V6
27	COM	7	V7
28	SLD	8	V8
29	COM	9	NC
30	COM	10	NC
31	COM	11	NC
32	SLD	12	NC
33	COM	13	NC
34	SLD	14	NC
35	COM	15	NC
36	SLD	16	NC
37	COM	17	NC
38	SLD	18	NC
39	SLD	19	NC
40	COM	20	NC