

RTD INPUT MODULE

(high accuracy, 4 points, isolated, tension clamp terminal block)

MODEL R3S-RS4A**BEFORE USE**

Thank you for choosing M-System. Before use, please check contents of the package you received as outlined below.

If you have any problems or questions with the product, please contact M-System's Sales Office or representatives.

■ PACKAGE INCLUDES:

RTD input module.....(1)

■ MODEL NO.

Confirm Model No. marking on the product to be exactly what you ordered.

■ INSTRUCTION MANUAL

This manual describes necessary points of caution when you use this product, including installation, connection and basic maintenance procedures.

POINTS OF CAUTION**■ HOT SWAPPABLE MODULES**

- Replacing the module does not affect other modules on the same base. Thus, the module can be replaced while the power is ON. However, replacing multiple modules at once may greatly change live voltage levels. We highly recommend to replace them one by one.

■ GENERAL PRECAUTIONS

- DO NOT set the switches on the module while the power is supplied. The switches are used only for maintenance without the power.

■ ENVIRONMENT

- Indoor use.
- When heavy dust or metal particles are present in the air, install the unit inside proper housing with sufficient ventilation.
- Do not install the unit where it is subjected to continuous vibration. Do not subject the unit to physical impact.
- Environmental temperature must be within -10 to +55°C (14 to 131°F) with relative humidity within 30 to 90% RH in order to ensure adequate life span and operation.

■ WIRING

- Do not install cables close to noise sources (relay drive cable, high frequency line, etc.).
- Do not bind these cables together with those in which noises are present. Do not install them in the same duct.

■ AND

- The unit is designed to function as soon as power is supplied, however, a warm up for 10 minutes is required for satisfying complete performance described in the data sheet.

INSTALLATION

Use the Installation Base (model: R3-BSx).

COMPONENT IDENTIFICATION

FRONT VIEW

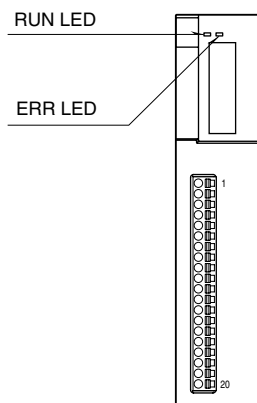

SIDE VIEW

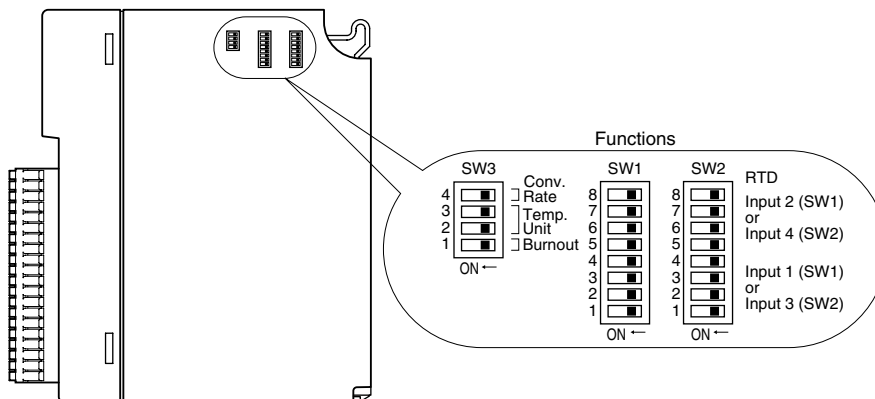

STATUS INDICATOR LED

RUN indicator: Bi-color (red/green) LED;
 Red when the bus A operates normally;
 Green when the bus B operates normally;
 Amber when both buses operate normally.

ERR indicator: Bi-color (red/green) LED;
 Red with burnout;
 Green in normal operating conditions.

SIDE DIP SW

(*) Factory setting

• RTD Type: SW1, SW2

INPUT 1 (SW1)				INPUT 2 (SW1)				RTD
INPUT 3 (SW2)				INPUT 4 (SW2)				
1	2	3	4	5	6	7	8	
OFF	OFF	OFF	OFF	OFF	OFF	OFF	OFF	Pt 100 (*) (JIS '97, IEC)
ON	OFF	OFF	OFF	ON	OFF	OFF	OFF	Pt 100 (JIS '89)
OFF	ON	OFF	OFF	OFF	ON	OFF	OFF	JPt 100 (JIS '89)
OFF	ON	ON	OFF	OFF	ON	ON	OFF	Pt 1000

• Burnout: SW3-1

SW3-1	BURNOUT
OFF	Upscale (*)
ON	Downscale

• Temperature Unit: SW3-2, 3-3

SW3-2	SW3-3	TEMP. UNIT
OFF	OFF	°C (*)
ON	OFF	°F

• Conversion Rate: SW3-4

SW3-4	CONV. RATE
OFF	250 msec. (*)
ON	1 sec.

PC CONFIGURATOR

With configurator software, settings shown below are available.
Refer to the software manual of R3CON for detailed operation.

■ CHANNEL INDIVIDUAL SETTING

PARAMETER	AVAILABLE RANGE	DEFAULT SETTING
Zero Scale	-32000 to +32000	0
Full Scale	-32000 to +32000	10000
Zero Adjust	-320.00 to +320.00	0.00
Full Adjust	-32000 to +32000	1.0000
Zero Base	Depends on sensor type	0.00
Full Base	Depends on sensor type	0.00
Unused	0: Enable 1: Disable	0: Enable

■ CHANNEL BATCH SETTING

PARAMETER	AVAILABLE RANGE	DEFAULT SETTING
Limit	No check mark: Limits to the scaling values equivalent to -15 % to +115 %. Check-marked: Limits within Zero Scale to Full Scale.	No check mark

INPUT DATA DESCRIPTIONS

■ ANALOG DATA (TEMPERATURE DATA)

16-bit binary data.

With °C temperature unit, raw data is multiplied by 100. For example, 25.5°C is converted into 2550.

With °F temperature unit, raw data is multiplied by 10. For example, 135.4°F is converted into 1354.

Minus temperature is converted into negative values, represented in 2's complements.

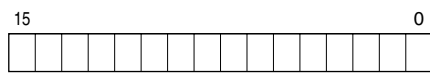

TERMINAL CONNECTIONS

Connect the unit as in the diagram below.

■ EXTERNAL DIMENSIONS unit: mm (inch)

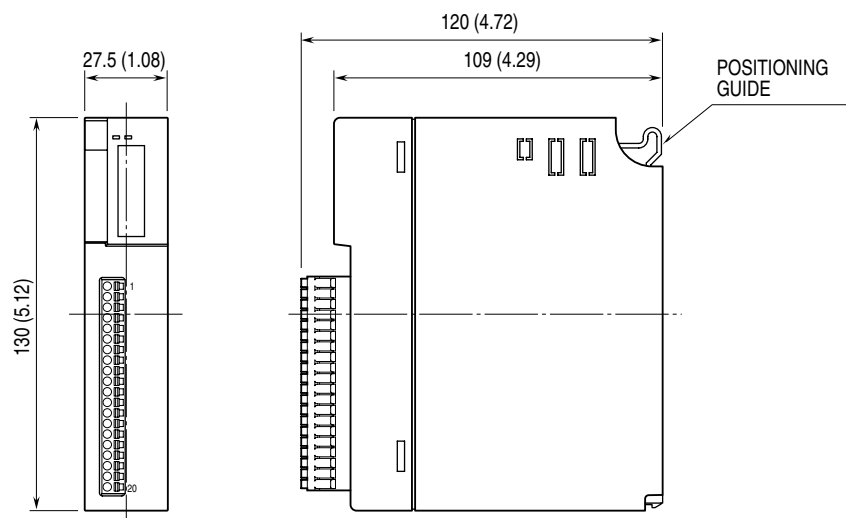

■ CONNECTION DIAGRAM

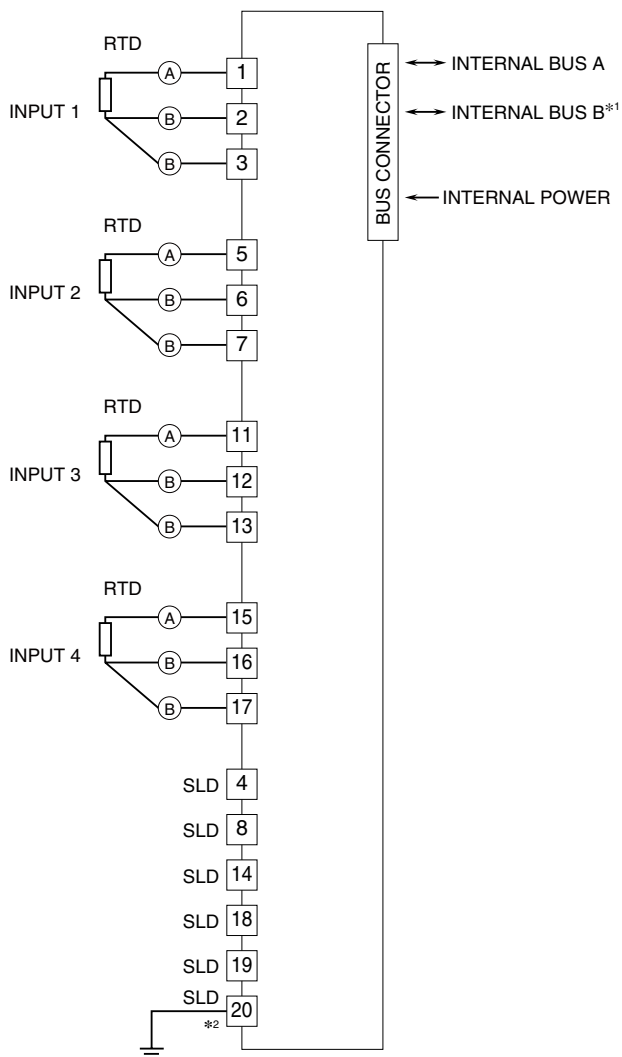

*1. For dual redundant communication.
 *2. To make use of shield line, connect to SLD and ground the terminal 20's shield.
 Note: Do not use void terminals.

• Unused Input Channels

Close across the unused input terminals with a resistor as shown below and set the DIP switch for Pt 100 input.

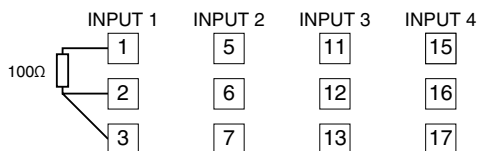

Unused channels left open are equal to the burnout, which turns the red ERR LED on and sets a burnout flag at the PLC or the host device.

Unused channels can be specified and set so on the PC Configurator Software (model: R3CON) without needing to connect resistors at the field terminals.

WIRING INSTRUCTIONS

■ APPLICABLE WIRE SIZE

- Solid: 0.2 to 1.0 mm² (0.55 to 1.12 dia.)
 - Stranded: 0.2 to 1.5 mm²
- (Tinning wire ends may cause contact failure and therefore is not recommended.)

• Ferruled:

Unsheathed: 0.25 to 1.5 mm²

Sheathed: 0.25 to 0.75 mm²

- Expose wire conductors by 10 mm (0.39").

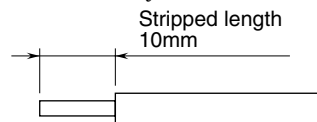

■ CONNECTION PROCEDURE

Insert the wire end until it comes to a full stop while pushing slot with the tip of a screw driver as shown below. Be sure wire insulation is not inside the terminal.

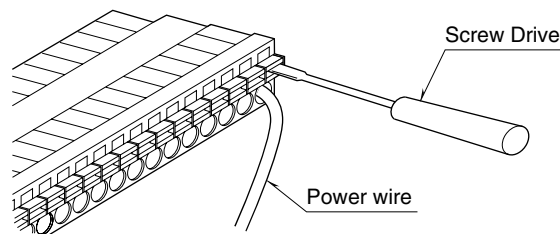

INPUT PIN ASSIGNMENT

PIN No.	FUNCTION
1	INA1
2	INB1
3	INb1
4	SLD
5	INA2
6	INB2
7	INb2
8	SLD
9	NC
10	NC
11	INA3
12	INB3
13	INb3
14	SLD
15	INA4
16	INB4
17	INb4
18	SLD
19	SLD
20	SLD