

**BEFORE USE ....**

Thank you for choosing M-System. Before use, please check contents of the package you received as outlined below.

If you have any problems or questions with the product, please contact M-System's Sales Office or representatives.

**■ PACKAGE INCLUDES:**

Encoder input module.....(1)

**■ MODEL NO.**

Confirm Model No. marking on the product to be exactly what you ordered.

**■ INSTRUCTION MANUAL**

This manual describes necessary points of caution when you use this product, including installation, connection and basic maintenance procedures.

**POINTS OF CAUTION****■ CONFORMITY WITH EU DIRECTIVES**

- The equipment must be mounted inside the instrument panel of a metal enclosure.
- The actual installation environments such as panel configurations, connected devices, connected wires, may affect the protection level of this unit when it is integrated in a panel system. The user may have to review the CE requirements in regard to the whole system and employ additional protective measures to ensure the CE conformity.

**■ HOT SWAPPABLE MODULES**

- Replacing the module does not affect other modules on the same base. Thus, the module can be replaced while the power is ON. However, replacing multiple modules at once may greatly change live voltage levels. We highly recommend to replace them one by one.

**■ GENERAL PRECAUTIONS**

- DO NOT set the switches on the module while the power is supplied. The switches are used only for maintenance without the power.

**■ ENVIRONMENT**

- Indoor use.
- When heavy dust or metal particles are present in the air, install the unit inside proper housing with sufficient ventilation.
- Do not install the unit where it is subjected to continuous vibration. Do not subject the unit to physical impact.
- Environmental temperature must be within -10 to +55°C (14 to 131°F) with relative humidity within 30 to 90% RH in order to ensure adequate life span and operation.

**■ WIRING**

- Do not install cables close to noise sources (relay drive cable, high frequency line, etc.).
- Do not bind these cables together with those in which noises are present. Do not install them in the same duct.

**■ AND ....**

- The unit is designed to function as soon as power is supplied, however, a warm up for 10 minutes is required for satisfying complete performance described in the data sheet.

**INSTALLATION**

Use the Installation Base (model: R3-BSx).

## COMPONENT IDENTIFICATION

### FRONT VIEW

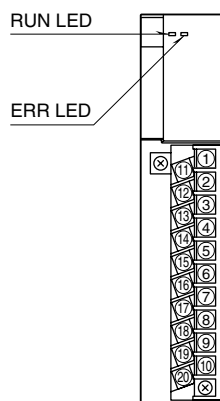

### SIDE VIEW

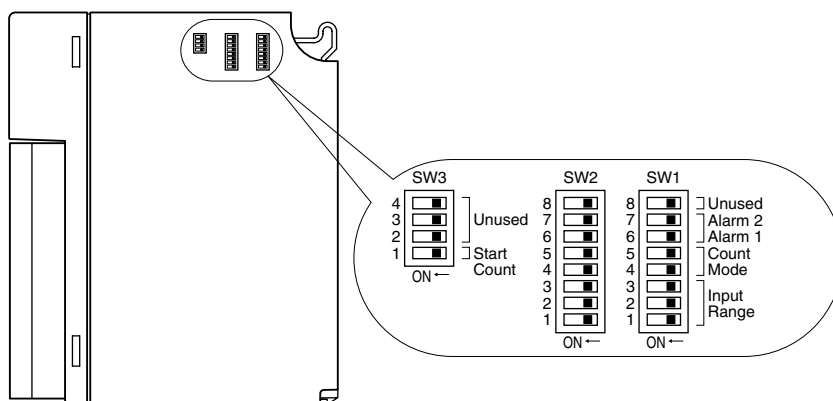

### STATUS INDICATOR LED

**RUN indicator:** Bi-color (red/green) LED;

Red when the bus A operates normally;  
Green when the bus B operates normally;  
Amber when both buses operate normally.

**ERR indicator:** Green LED turns on in normal operating conditions.

### SIDE DIP SW

(\*) Factory setting

#### • Input Range: SW1-1 through 1-3, SW2-1 through 2-3

INPUT 1 (SW1)			INPUT RANGE
INPUT 2 (SW2)			
1	2	3	
OFF	OFF	OFF	0 – 100 kHz (*)
ON	OFF	OFF	0 – 10 kHz
OFF	ON	OFF	0 – 1 kHz
ON	ON	OFF	0 – 100 Hz
OFF	OFF	ON	0 – 10 Hz
ON	OFF	ON	0 – 1 Hz
OFF	ON	ON	0 – 0.1 Hz

#### • Count Mode: SW1-4, 1-5, SW2-4, 2-5

INPUT 1 (SW1)		COUNT MODE
INPUT 2 (SW2)		
4	5	
OFF	OFF	Mode 0 : 1 count / pulse (*)
ON	OFF	Mode 1 : 1 count / pulse
OFF	ON	Mode 2 : 2 counts / pulse
ON	ON	Mode 3 : 4 counts / pulse

#### • Alarm Contact Form: SW1-6, 1-7, SW2-6, 2-7

INPUT 1 (SW1)		ALARM CONTACT FORM
INPUT 2 (SW2)		
ALARM 1	ALARM 2	
6	7	
OFF	OFF	ON (short) at alarm (*)
ON	OFF	OFF (open) at alarm

#### • Start Count: SW3-1

SW	START COUNT AT POWER ON	
	0*1 count (*)	Stored count
SW3-1	OFF	ON

\*1. Start (Reset) count can be modified using the R3CON PC Configurator software.

Note: Be sure to set unused SW1-8, SW2-8 and SW3-2 through 3-4 to OFF.

## PC CONFIGURATOR

With configurator software, settings shown below are available.  
Refer to the software manual of R3CON for detailed operation.

### ■ CHANNEL INDIVIDUAL SETTING

PARAMETER	AVAILABLE RANGE	DEFAULT SETTING	
Zero Scale	-32000 to +32000	0	
Full Scale	-32000 to +32000	10000	
Max Position	0 to 100,000,000	100,000,000	
Reset Position	0 to 100,000,000	100,000,000	
Drop-Out	0.10 to 50.00 (%)	0.10 (%)	
Mode	1: Speed/High, 2: Speed/Low, 3: Position/High, 4: Position/Low	Alarm 1	1: Speed/High
		Alarm 2	2: Speed/Low
Alarm level	Speed: 0.00 to 100.00 (%) Position: -100,000,000 to 100,000,000	Alarm 1	Speed: 80.00 (%) Position: 100,000,000
		Alarm 2	Speed: 20.00 (%) Position: 100,000,000
Hyst.	Speed: 0.00 to 100.00 (%) Position: -100,000,000 to 100,000,000	Alarm 1	Speed: 5.00 (%) Position: 1,000
		Alarm 2	Speed: 5.00 (%) Position: 1,000

### ■ CHANNEL BATCH SETTING

PARAMETER	AVAILABLE RANGE	DEFAULT SETTING
Delay Time	0.0 to 60.0 (sec.)	0.1 (sec.)
Hold Time	0.0 to 60.0 (sec.)	0.1 (sec.)

## TERMINAL CONNECTIONS

Connect the unit as in the diagram below.

### ■ EXTERNAL DIMENSIONS unit: mm (inch)

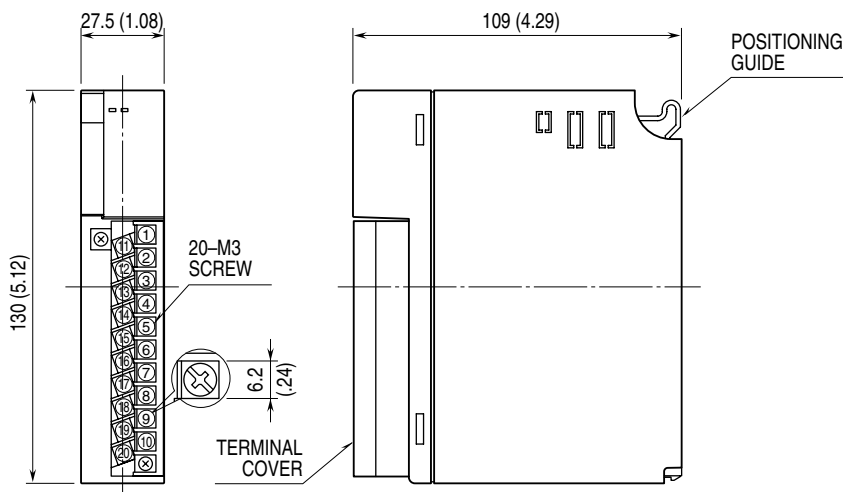

■ CONNECTION DIAGRAM

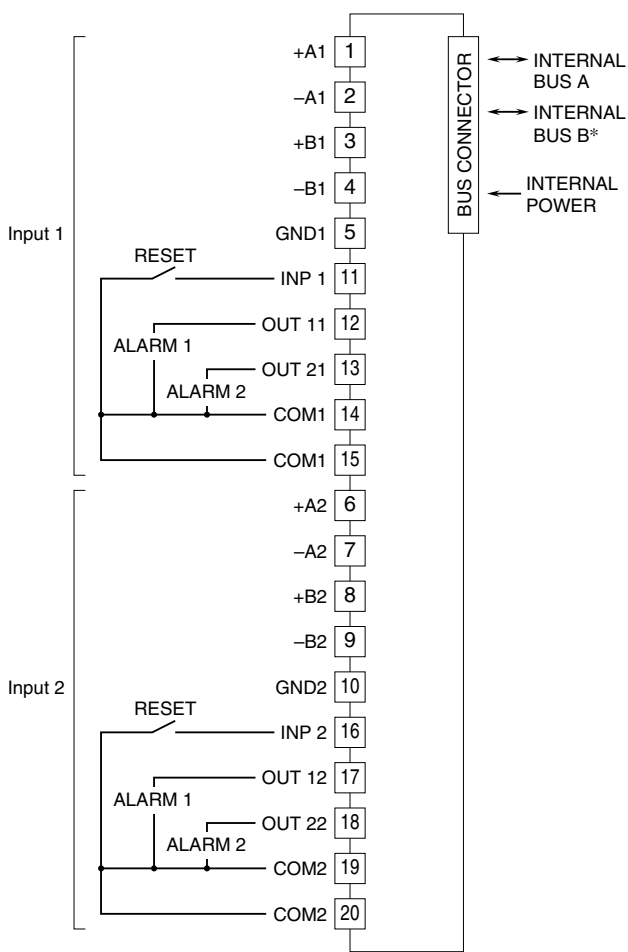

\*For dual redundant communication.

WIRING INSTRUCTIONS

■ SCREW TERMINAL

Torque: 0.5 N·m

■ SOLDERLESS TERMINAL

Refer to the drawing below for recommended ring tongue terminal size. Spade tongue type is also applicable. Solderless terminals with insulation sleeve do not fit.

Applicable wire size: 0.3 – 0.75 mm<sup>2</sup>

Recommended manufacturer: Japan Solderless Terminal MFG. Co., Ltd., Nichifu Co., Ltd.

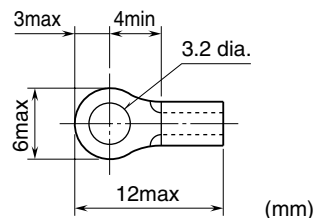

COUNT MODE

■ MODE 0

1 count / 1 input pulse (count at either edge of phase A or B)

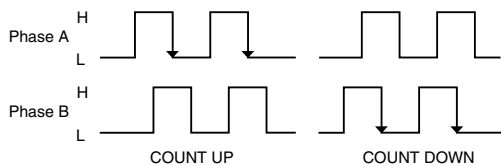

■ MODE 2

2 counts / 1 input pulse (count at both edges of phase B)

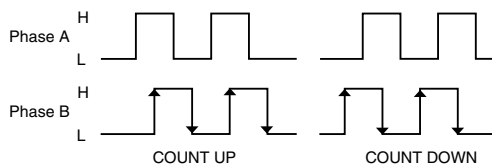

■ MODE 1

1 count / 1 input pulse (count at either edge of phase A)

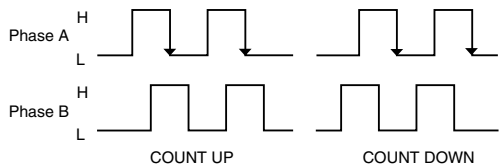

■ MODE 3

4 counts / 1 input pulse (count at both edges of phase A and B)

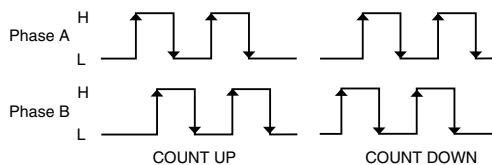

## I/O DATA

