

**CC-Link INTERFACE MODULE**  
(CC-Link Ver.1.10; for 16-point analog signals)

MODEL **R3-NC1**

**BEFORE USE ....**

Thank you for choosing M-System. Before use, please check contents of the package you received as outlined below. If you have any problems or questions with the product, please contact M-System's Sales Office or representatives.

**■ PACKAGE INCLUDES:**

- Network interface module .....(1)
- Terminating resistor (110 Ω, 0.5 W).....(1)

**■ MODEL NO.**

Confirm Model No. marking on the product to be exactly what you ordered.

**■ INSTRUCTION MANUAL**

This manual describes necessary points of caution when you use this product, including installation, connection and basic maintenance procedures.

**POINTS OF CAUTION**

**■ CONFORMITY WITH EU DIRECTIVES**

- The equipment must be mounted inside the instrument panel of a metal enclosure.
- The actual installation environments such as panel configurations, connected devices, connected wires, may affect the protection level of this unit when it is integrated in a panel system. The user may have to review the CE requirements in regard to the whole system and employ additional protective measures to ensure the CE conformity.

**■ HOT SWAPPABLE MODULES**

- The module can be replaced while the power is ON. Be sure to replace it when the module is not communicating with a host, as it may affect the system. Replacing multiple modules at once may greatly change line voltage levels. We highly recommend to replace them one by one.

**■ POWER INPUT RATING & OPERATIONAL RANGE**

- Locate the power input rating marked on the product and confirm its operational range as indicated below:  
 100 – 120V AC rating: 85 – 132V, 47 – 66 Hz, approx. 20VA  
 200 – 240V AC rating: 170 – 264V, 47 – 66 Hz, approx. 20VA  
 24V DC rating: 24V ±10%, approx. 12W

**■ GENERAL PRECAUTIONS**

- DO NOT set the switches on the module while the power is supplied. The switches are used only for maintenance without the power.

**■ ENVIRONMENT**

- Indoor use.
- When heavy dust or metal particles are present in the air, install the unit inside proper housing with sufficient ventilation.
- Do not install the unit where it is subjected to continuous vibration. Do not subject the unit to physical impact.

- Environmental temperature must be within -10 to +55°C (14 to 131°F) with relative humidity within 30 to 90% RH in order to ensure adequate life span and operation.

**■ WIRING**

- Do not install cables close to noise sources (relay drive cable, high frequency line, etc.).
- Do not bind these cables together with those in which noises are present. Do not install them in the same duct.

**■ AND ....**

- The unit is designed to function as soon as power is supplied, however, a warm up for 10 minutes is required for satisfying complete performance described in the data sheet.

**INSTALLATION**

Use the Installation Base Model R3-BS, or Model R3-BSW for free I/O address capability.

Before mounting the Network Interface Module onto the Base, be sure to configure the module as explained below.

**■ DATA ALLOCATION**

The setting determines the data area size assigned to each I/O module mounted on the base. The data sent/received via CC-Link is mapped according to this setting. See "COMPONENT IDENTIFICATION" and "TRANSMISSION DATA DESCRIPTIONS".

**■ STATION NO., BAUD RATE, ETC.**

See "COMPONENT IDENTIFICATION".

**■ NETWORK SLOTS ON THE BASE**

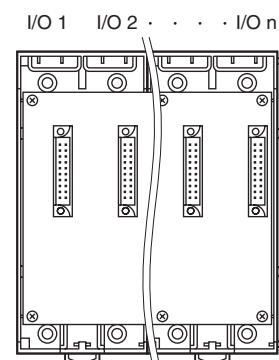

With Model R3-BS base, mount the I/O Modules from the left end (I/O 1) to the right in order that the Network Module assigns data areas from I/O 1. Network Module(s) and Power Module are mounted basically at the right end though technically they could be mounted in any position.

With Model R3-BSW base, there is no limitation in mounting positions as I/O address can be assigned freely to each module using rotary switches equipped on the base.

## COMPONENT IDENTIFICATION

### FRONT VIEW

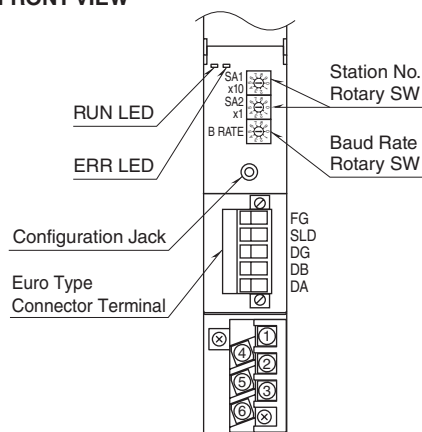

### SIDE VIEW

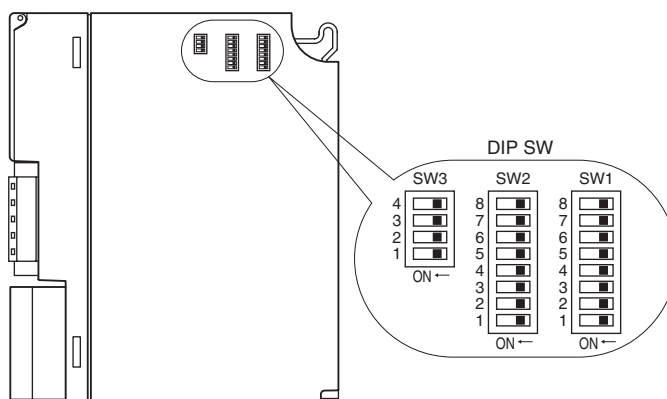

### BAUD RATE ROTARY SW

SW POSITION	BAUD RATE
0	156 kbps
1	625 kbps
2	2.5 Mbps
3	5 Mbps
4	10 Mbps
Other	Unused. ERR LED turns on if used.

### STATION NO. ROTARY SW: SA1, SA2

Station No. is set in decimal.  
(Setpoint adjustment: 01 – 64)

### SIDE DIP SW

(\*) Factory setting

#### Data Allocation: SW1, SW2

Data Allocation Type\* must be assigned to each I/O module position to specify how many data areas (four types) are to be occupied by each.

Two bits from SW1 and SW2 are assigned to each position, and data areas can be specified from the module No. 1 through 8. Setting for No. 9 and later modules is identical to No. 8.

SW ASSIGNMENT		MODULE NO.
SW1-1	SW1-2	1
SW1-3	SW1-4	2
SW1-5	SW1-6	3
SW1-7	SW1-8	4
SW2-1	SW2-2	5
SW2-3	SW2-4	6
SW2-5	SW2-6	7
SW2-7	SW2-8	8
SW SETTING		DATA ALLOCATION
OFF	OFF	1
ON	OFF	4
OFF	ON	8
ON	ON	16

\*Refer to the specifications of the related series for the Data Allocation Type of I/O modules.

### Dual Communication: SW3-1

When two network modules are mounted, one must be 'Main' (OFF) network and the other must be 'Sub' (ON) network. For single communication, the network module must always be set to 'Main' (OFF).

SW	DUAL COMMUNICATION	
	MAIN (*)	SUB
SW3-1	OFF	ON

### Input Error Data: SW3-2

**Hold:** When the communication from an input module is lost due to the input module error, the network module holds the signal and stands by until the communication recovers.

**Set to '0':** When the communication from an input module is lost due to the input module error, the network module outputs '0.'

SW	INPUT ERROR DATA	
	HOLD (*)	SET '0'
SW3-2	OFF	ON

### LED Function: SW3-4

Functions assigned to the front RUN and ERR LEDs can be selected.

SW3-4	LED FUNCTION	
	RUN	ERR
OFF (*)	Green when normal	Green when abnormal
ON	Red when receiving	Red when transmitting

Note: Be sure to set unused SW3-3 to OFF.

## PC CONFIGURATOR

The following parameter items can be set with using PC Configurator Software (model: R3CON). Refer to the users manual for the R3CON for detailed operation of the software program.

### NETWORK MODULE SETTING

PARAMETER	SETTING RANGE	DEFAULT SETTING
Time (no communication time)	0.2 – 3200.0 (sec.)	3.0 (sec.)

## TERMINAL CONNECTIONS

Connect the unit as in the diagram below.

### EXTERNAL DIMENSIONS unit: mm (inch)

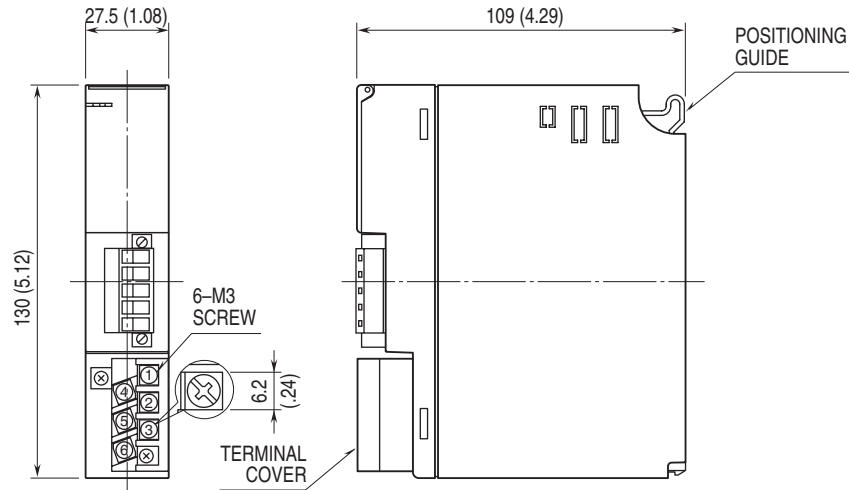

### CONNECTION DIAGRAM

Note: In order to improve EMC performance, bond the FG terminal to ground.

Caution: FG terminal is NOT a protective conductor terminal.

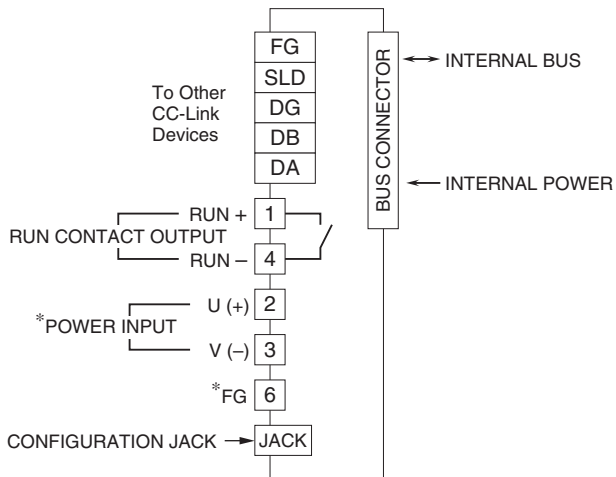

\*Not provided with 'No Power Supply' type module.

## WIRING INSTRUCTIONS

### M3 SCREW TERMINAL (power input, RUN contact output)

Torque: 0.5 N·m

### SOLDERLESS TERMINAL

Refer to the drawing below for recommended ring tongue terminal size. Spade tongue type is also applicable. Solderless terminals with insulation sleeve do not fit.

Recommended manufacturer: Japan Solderless Terminal MFG.Co.Ltd, Nichifu Co.,ltd

Applicable wire size: 0.75 to 1.25 mm<sup>2</sup>

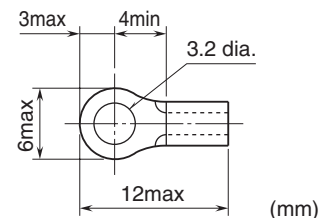

### EURO TYPE CONNECTOR TERMINAL (CC-Link)

Applicable wire size: 0.2 to 2.5 mm<sup>2</sup> (AWG24 to 12)

Stripped length: 7 mm

## COMMUNICATION CABLE CONNECTIONS

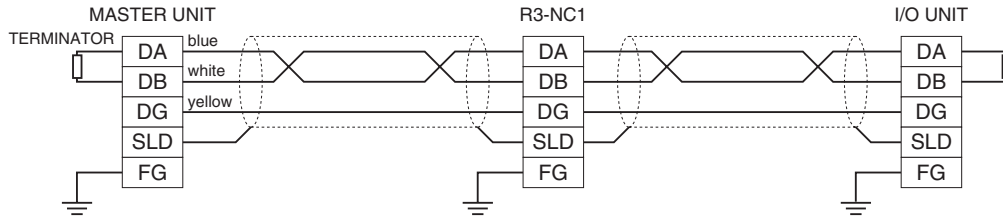

## TRANSMISSION DATA DESCRIPTIONS

The DIP SW located at the side of the module specifies each I/O module's data allocation (occupied data area). For example, when the data areas are assigned as shown below:

Module 1	4
Module 2	4
Module 3	4
Module 4	1
Module 5	1
Module 6	1
Module 7	1

Then the I/O data are assigned as in the figures below:

### ■ OUTPUT DATA

The figure below shows the allocation of the data sent from the network module to the master.

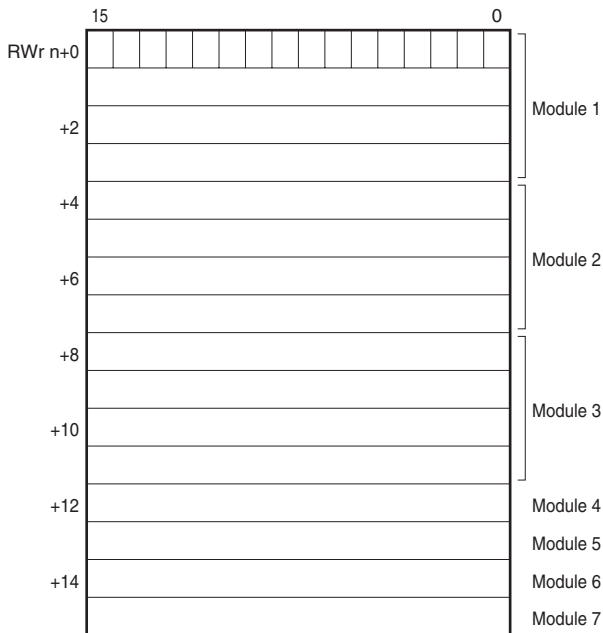

### ■ INPUT DATA

The figure below shows the allocation of the data sent from the master to the network module.

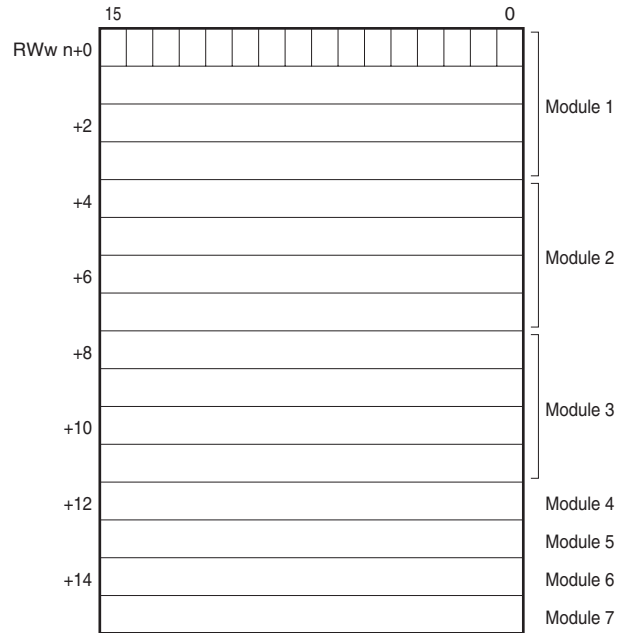

Sixteen (16) data areas are available to the R3-NC1. Total data areas occupied by I/O modules must be within this limitation.

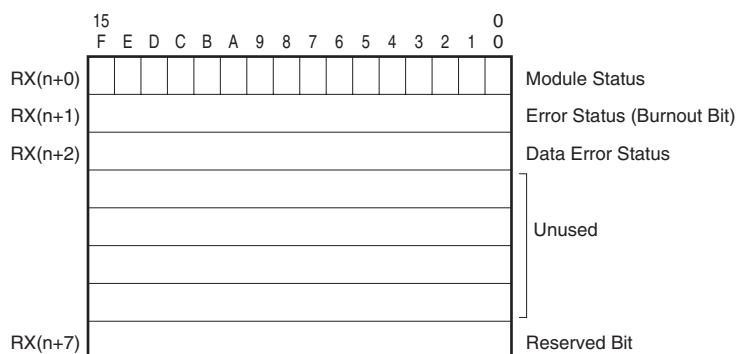

- **Module Status**

RX(n+0)0 through RX(n+0)F indicate whether individual I/O modules are mounted or not. The bit corresponding to the mounted slot turns to “1,” and the unmounted slot to “0.”

- **Error Status**

RX(n+1)0 through RX(n+1)F indicate error status for each module as described below. The bit corresponding to such module turns to “1.”

R3-TSx, R3-RSx, R3-US4: Input burnout

R3-DA16A: Power input in error or disconnected

R3-YSx: Output current error (e.g. load unconnected)

R3-PC16A: External power supply in error or disconnected

- **Data Error Status**

RX(n+2)0 through RX(n+2)F indicate overrange (R3-US4: out of -10% to +110%; the other types: out of -15% to +115%) status for each module. The bit corresponding to such module turns to “1.”

- RX(n+3) through RX(n+6) are unused.

- RX(n+7)0 through RX(n+7)7 are reserved for future use. RX(n+7)B is assigned to Ready signal, which is turned to “1” when the network module is in normal conditions. RX(n+7)8 through RX(n+7)A, RX(n+7)C through RX(n+7)F are not used.

RX(n+0) 0, RX(n+1) 0, RX(n+2) 0	Module 1
RX(n+0) 1, RX(n+1) 1, RX(n+2) 1	Module 2
RX(n+0) 2, RX(n+1) 2, RX(n+2) 2	Module 3
:	:
RX(n+0) F, RX(n+1) F, RX(n+2) F	Module 16

## MODULE STATUS, ERROR STATUS, DATA ERROR STATUS

Shows each module's availability and error status.

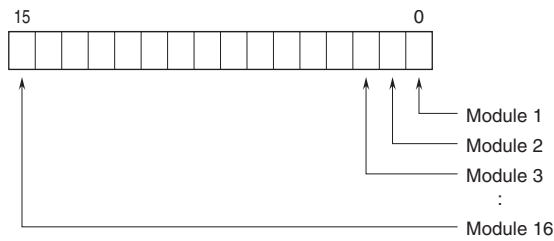

## I/O DATA DESCRIPTIONS

The data allocations for typical I/O modules are shown below.  
Refer to the manual for each module for detailed data allocations.

### ■ ANALOG DATA (16-bit data, models: R3-SV4, YV4, DS4, YS4 and US4, etc.)

16-bit binary data.

Basically, 0 to 100% of the selected I/O range is converted into 0 to 10000 (binary).

-15 to 0 % is a negative range represented in 2's complement.

In case of R3-US4, -10 to 0% is a negative range represented in 2's complement.



### ■ TEMPERATURE DATA (16-bit data, models: R3-RS4, TS4 and US4, etc.)

16-bit binary data.

With °C temperature unit, raw data is multiplied by 10. For example, 25.5°C is converted into 255.

With °F temperature unit, the integer section of raw data is directly converted into the data. For example, 135.4°F is converted into 135.

Minus temperature is converted into negative values, represented in 2's complements.



### ■ ANALOG DATA (16-bit data, models: R3-CT4A, CT4B, etc.)

16-bit binary data.

Integer obtained by multiplying unit value (A) by 100.

In case of CLSE-R5, integer obtained by multiplying unit value (A) by 1000.



### ■ ACCUMULATED COUNT DATA (32-bit data, models: R3-PA2, PA4A, WT1, WT4, etc.)

32-bit binary data is used for accumulated counts and encoder positions.

Lower 16 bits are allocated from the lowest address to higher ones, higher 16 bits in turn.



### ■ BCD DATA (32-bit data, models: R3-BA32A, BC32A, etc.)

32-bit binary data is used for BCD.

Lower 16 bits are allocated from the lowest address to higher ones, higher 16 bits in turn.



### ■ DISCRETE DATA (models: R3-DA16 and DC16, etc.)

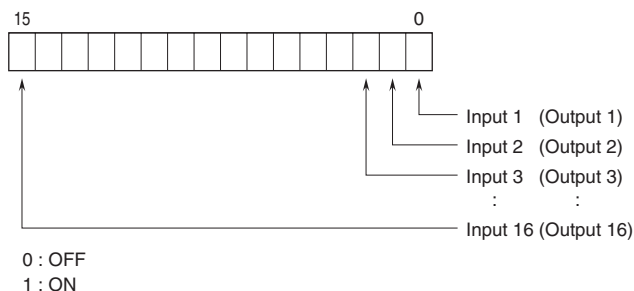

### ■ PLC REDUNDANT SYSTEM (models: R3-NC1-x/W)

Bit 0 of RY(n+1) is assigned to designate control system or standby system. Set this bit from the host PLC to switch from the PLC master control system to the standby system, or vice versa. The R3 module output (slave station) is controlled according to the bit combinations as shown in the table below. No switching is required for the R3 input modules which continuously send out data to both 'main' and 'sub' network modules.

RY(n+1) 0 = 0 : PLC master control system

RY(n+1) 0 = 1 : PLC standby system

R3 MAIN (RY(n+1) 0)	R3 SUB (RY(n+1) 0)	CONTROL
0	0	Output from the 'main' network module.
0	1	Output from the 'main' network module.
1	0	Output from the 'sub' network module.
1	1	Hold the output

#### • Operation

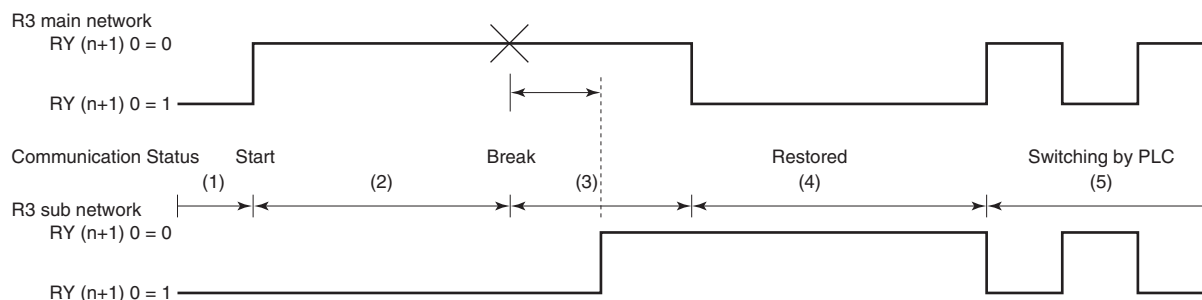

- 1) When the PLC master control/standby system bit is undefined due to no communication, the both host PLCs function as 'standby' system for each of R3 'main' and 'sub' network modules. All contact outputs are off, and analog output modules output -15%.
- 2) The master PLC communicates with the R3 main network module, while the standby PLC communicates with the R3 sub network module.
- 3) When a wire breakdown is detected at the R3 main network, the output signal is held for the preset time period (Timer is programmable with the PC Configurator Software, R3CON). After the time has been elapsed, the output is switched from the R3 main to R3 sub network. Be sure to set an appropriate output signal to the R3 sub network before the switching. The host PLC for the R3 main network is now functioning as standby system.
- 4) Once the PLC control is transferred to the standby system, it is necessary to set RY(n+1) 0 = 1 to the R3 main network in order to prevent R3 output control automatically switched to the main network when the R3 main network is restored. If it is set to RY(n+1) 0 = 0, the R3 output will be switched to the main network even when the PLC control is in the standby system.
- 5) When both R3 main and R3 sub network modules are in communication, the output can be switched without delay by setting RY(n+1) 0 values. Be sure to set an appropriate output signal to the network module before the control is switched to it.

## PARAMETERS SETTING BY PLC PROGRAM

The ladder diagram below shows a program example assuming that the master station's first I/O number is X/Y20 to 3F. For detailed information, refer to users manuals for the PLC CPU and the Master Unit.

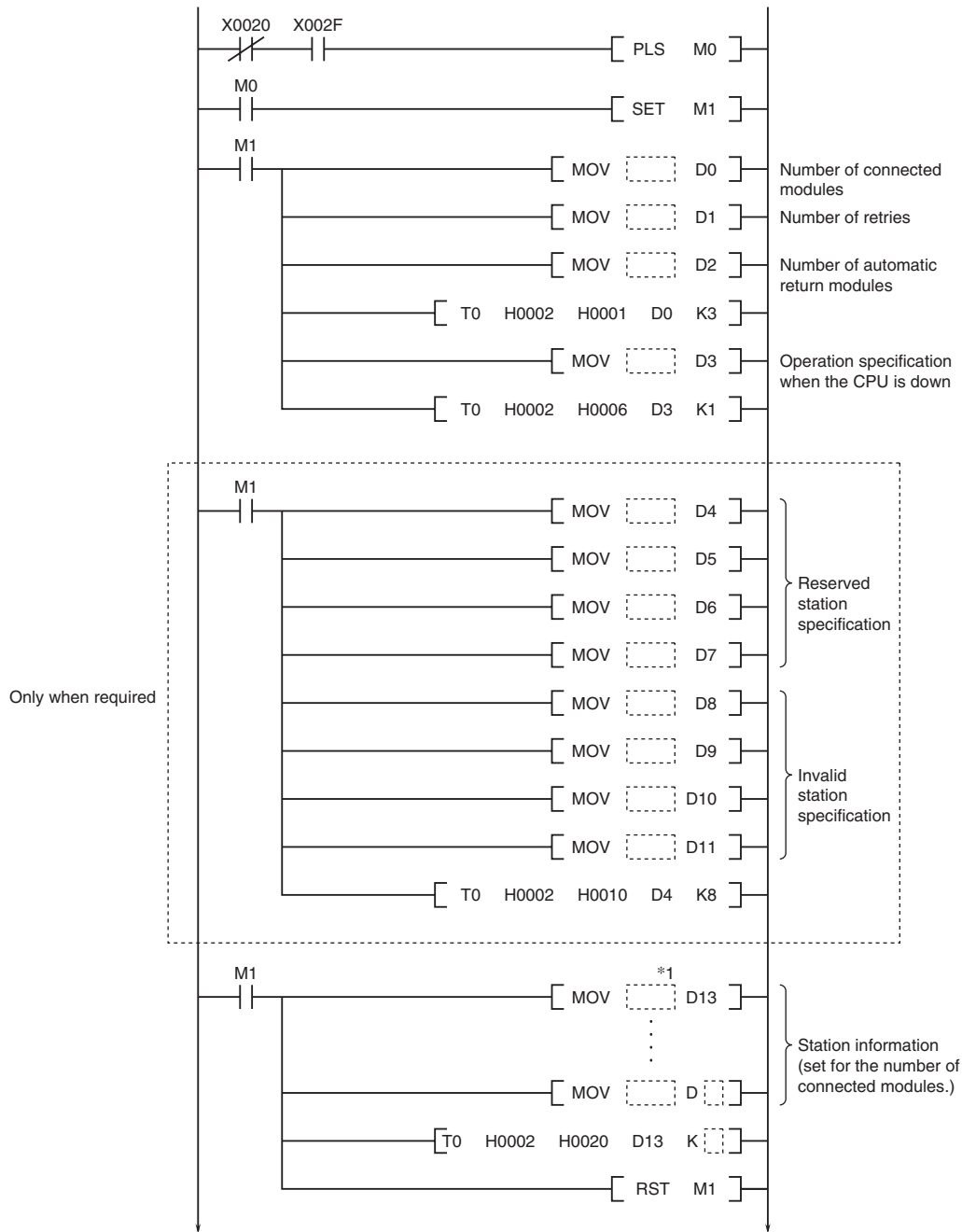

\*1. [Example] 14xx for model R3-NC1

xx =R3-NC1 Station address.