

BEFORE USE

Thank you for choosing M-System. Before use, please check contents of the package you received as outlined below. If you have any problems or questions with the product, please contact M-System's Sales Office or representatives.

■ PACKAGE INCLUDES:

Network interface module(1)

■ MODEL NO.

Confirm that the model number described on the product is exactly what you ordered.

■ INSTRUCTION MANUAL

This manual describes necessary points of caution when you use this product, including installation, connection and basic maintenance procedures.

■ EDS FILE

EDS files are downloadable at M-System's web site:
<http://www.m-system.co.jp>

POINTS OF CAUTION

■ CONFORMITY WITH EU DIRECTIVES

- The equipment must be mounted inside the instrument panel of a metal enclosure.
- The actual installation environments such as panel configurations, connected devices, connected wires, may affect the protection level of this unit when it is integrated in a panel system. The user may have to review the CE requirements in regard to the whole system and employ additional protective measures to ensure the CE conformity.

■ HOT SWAPPABLE MODULES

- The module can be replaced while the power is ON. Be sure to replace it when the module is not communicating with a host, as it may affect the system. Replacing multiple modules at once may greatly change line voltage levels. We highly recommend to replace them one by one.

■ GENERAL PRECAUTIONS

- DO NOT set the switches on the module while the power is supplied. The switches are used only for maintenance without the power.

■ ENVIRONMENT

- Indoor use.
- When heavy dust or metal particles are present in the air, install the unit inside proper housing with sufficient ventilation.
- Do not install the unit where it is subjected to continuous vibration. Do not subject the unit to physical impact.
- Environmental temperature must be within -10 to +55°C (14 to 131°F) with relative humidity within 30 to 90% RH in order to ensure adequate life span and operation.

■ WIRING

- Do not install cables close to noise sources (relay drive cable, high frequency line, etc.).
- Do not bind these cables together with those in which noises are present. Do not install them in the same duct.

■ AND

- The unit is designed to function as soon as power is supplied, however, a warm up for 10 minutes is required for satisfying complete performance described in the data sheet.

INSTALLATION

Use the Installation Base Model R3-BS, or Model R3-BSW for free I/O address capability.

Before mounting the Network Interface Module onto the base, be sure to configure the module as explained below.

■ MODULE ALLOCATION

Use the side DIP SW1 to set the number of slots which the module is assigned to. See "TRANSMISSION DATA DESCRIPTIONS".

■ NODE ADDRESS & BAUD RATE

See "COMPONENT IDENTIFICATION".

■ NETWORK SLOTS ON THE BASE

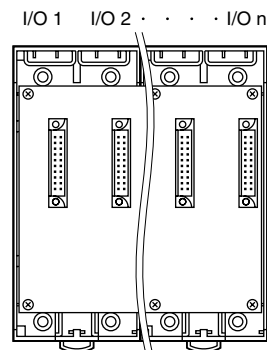

With Model R3-BS base, mount the I/O Modules from the left end (I/O 1) to the right in order that the Network Module assigns data areas from I/O 1.

Network Module(s) and Power Module are mounted basically at the right end though technically they could be mounted in any position.

With Model R3-BSW base, there is no limitation in mounting positions as I/O address can be assigned freely to each module using rotary switches equipped on the base.

R3-GD1 occupies up to 16 slots. Be careful not to use the slot numbers occupied by this unit for real I/O modules to be mounted on the same base. Also, when mounting this unit, be careful about the slot position and the number of slots to be occupied so that any of the slot numbers will not be greater than 16. The Network module cannot read data for an I/O module assigned to slot No. 17 or later.

COMPONENT IDENTIFICATION

FRONT VIEW

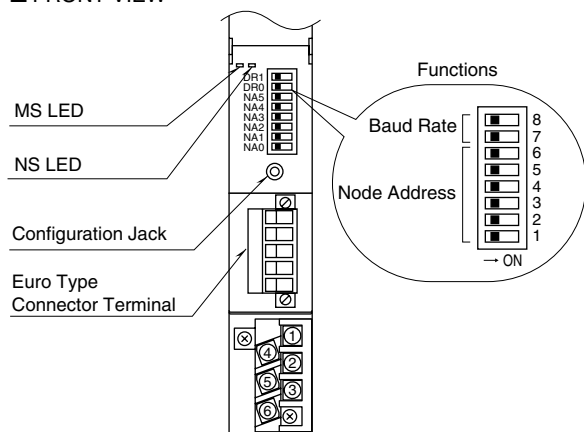

SIDE VIEW

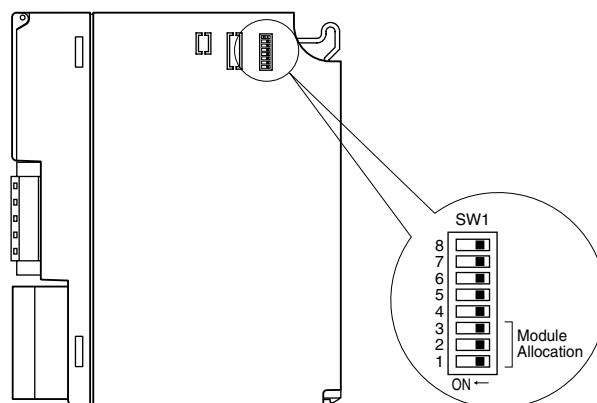

INDICATORS

The following table defines the LED states of the MS, and NS indicators.

ID	STATE	TO INDICATE
MS	Green	Operating in a normal condition
	Blinking Green	Standby (needs commissioning)
	Red	Critical failure
	Blinking Red	Minor failure
	OFF	No power supplied
NS	Green	Link on-line and connections in the established state
	Blinking Green	Link on-line but no connections in the established state
	Red	Critical link failure
	Blinking Red	Minor link failure
	OFF	No power supplied

Baud Rate: 7, 8 (DR0, DR1)

BAUD RATE	SW	
	7 (DR0)	8 (DR1)
125 kbps	OFF (*)	OFF (*)
250 kbps	ON	OFF
500 kbps	OFF	ON
N/A	ON	ON

SIDE DIP SW

Module Allocation: SW1-1, 1-2, 1-3

MODULE	SW1-1	SW1-2	SW1-3
1	OFF (*)	OFF (*)	OFF (*)
2	ON	OFF	OFF
3	OFF	ON	OFF
4	ON	ON	OFF

Note: Be sure to set unused SW1-4 through 1-8 to OFF.

FRONT DIP SW

(*) Factory setting.

Node Address: 1 – 6 (NA0 – NA5)

SW					
1 (NA0)	2 (NA1)	3 (NA2)	4 (NA3)	5 (NA4)	6 (NA5)
2^0	2^1	2^2	2^3	2^4	2^5

A node address is defined in 6-digit binary code. 1 – 6 (NA0 to NA5) correspond to the least to most significant digits.

DIP SW						NODE ADDRESS
6 NA5	5 NA4	4 NA3	3 NA2	2 NA1	1 NA0	
0	0	0	0	0	0	0
0	0	0	0	0	1	1
0	0	0	0	1	0	2
0	0	0	0	1	1	3
:	:	:	:	:	:	:
1	1	1	1	0	0	60
1	1	1	1	0	1	61
1	1	1	1	1	0	62
1	1	1	1	1	1	63

0 = OFF, 1 = ON

TERMINAL CONNECTIONS

Connect the unit as in the diagram below.

EXTERNAL DIMENSIONS unit: mm (inch)

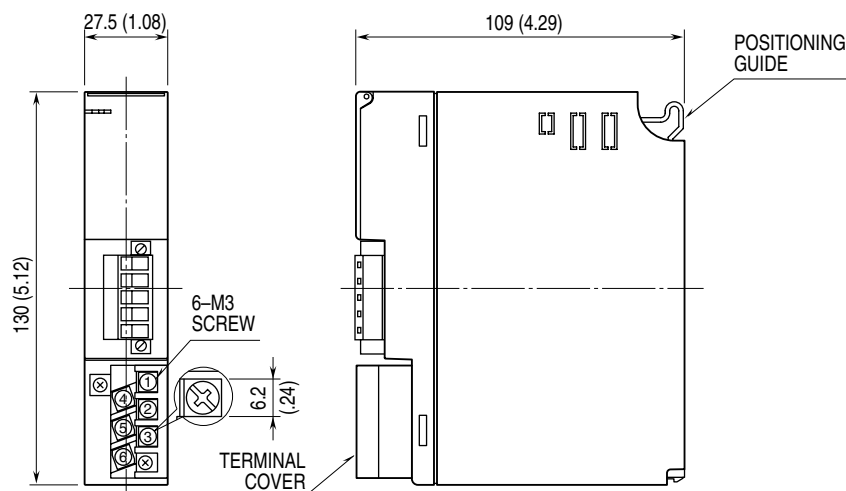

CONNECTION DIAGRAM

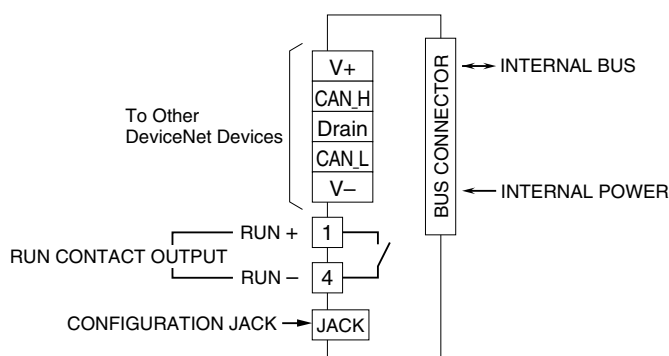

WIRING INSTRUCTIONS

M3 SCREW TERMINAL (RUN contact output)

Torque: 0.5 N·m

SOLDERLESS TERMINAL unit: mm (inch)

Refer to the drawing below for recommended ring tongue terminal size. Spade tongue type is also applicable. Solderless terminals with insulation sleeve do not fit.

Applicable wire size: 0.75 – 1.25 mm²

Recommended manufacturer: Japan Solderless Terminal MFG. Co.,Ltd., Nichifu Co.,Ltd.

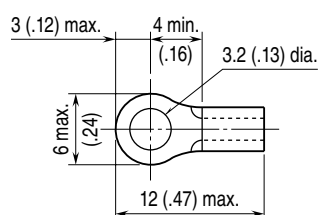

EURO TYPE CONNECTOR TERMINAL (DeviceNet)

Applicable wire size: 0.2 – 2.5 mm²

Stripped length: 7 mm

TRANSMISSION DATA DESCRIPTIONS

Use the DIP SW located at the side of the module to specify module allocation.

1 module is equivalent to 1 I/O module with 16 words analog input and 16 words analog output. Max. 4 modules (64 words input, 64 words output) transmission is available. R3-GD1 seems as if max. 4 I/O modules are mounted to 4 slots via DeviceNet.

Note: Do not mount any modules in the slots which are occupied by virtual modules. If a real I/O module is mounted in the slot, an internal bus error occurs and the ERR LED turns on. Max. 16 real I/O modules and virtual modules are available.
The interface module can not read the data for more than 16 modules.

■ WHEN R3-GD1 IS MOUNTED ON SLOT NO. 2 (4 modules)

Real I/O modules are mounted on Slots No. 1 and 2, however, the network module (R3-NE1) recognizes that each of Slots No. 1 to 5 is occupied. That is, R3-NE1 recognizes R3-SV4 mounted on Slot No.1 as it is and recognizes R3-GD1 mounted on Slot No.2 as divided into four modules and occupying Slots No. 2 to 5.

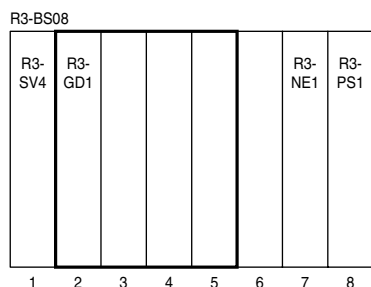

SLOT	REAL MODULE	VIRTUAL MODULE	NO. OF WORDS
Slot No. 1	R3-SV4	R3-SV4	4 Words
Slot No. 2	R3-GD1	R3-GD1 (1/4)	16 Words
Slot No. 3	No module	R3-GD1 (2/4)	16 Words
Slot No. 4	No module	R3-GD1 (3/4)	16 Words
Slot No. 5	No module	R3-GD1 (4/4)	16 Words
Slot No. 6	No module	No module	----
Slot No. 7	R3-NE1	R3-NE1	----
Slot No. 8	R3-PS1	R3-PS1	----

■ OUTPUT DATA

The figure below shows the allocation of the data sent from the network module to the master.

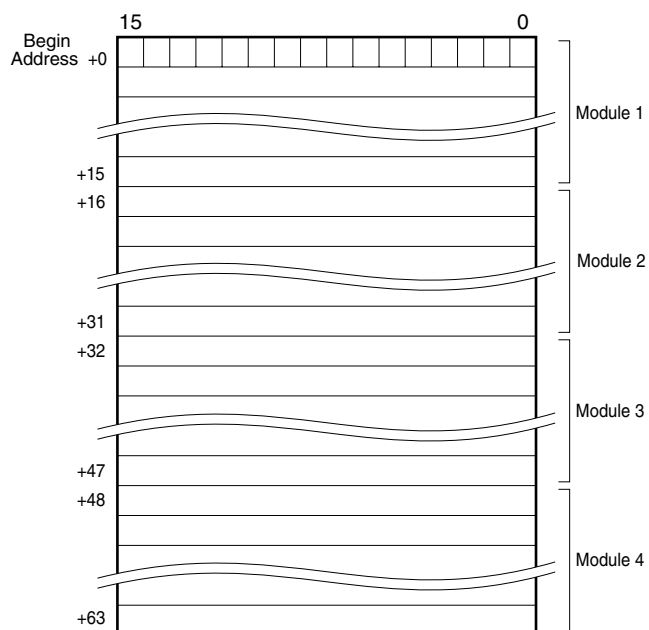

■ INPUT DATA

The figure below shows the allocation of the data sent from the master to the network module.

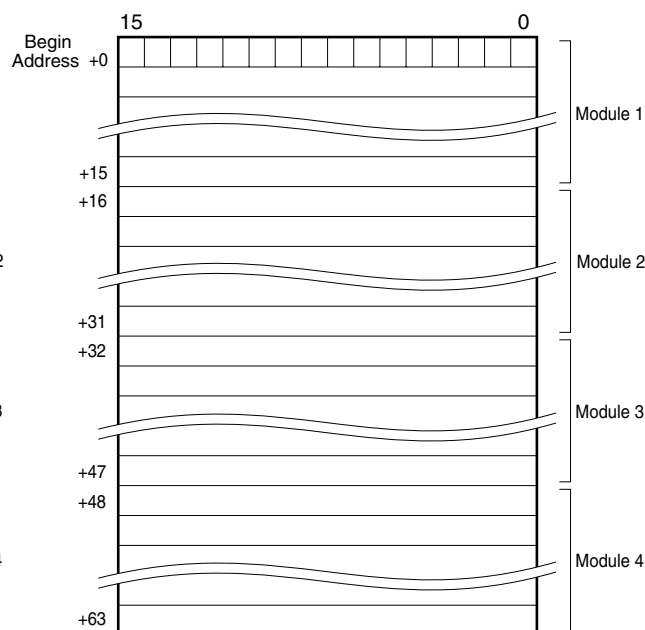

INPUT/OUTPUT DATA

■ ANALOG INPUT/OUTPUT DATA



16 bits binary data