

BEFORE USE

Thank you for choosing M-System. Before use, please check contents of the package you received as outlined below.

If you have any problems or questions with the product, please contact M-System's Sales Office or representatives.

■ PACKAGE INCLUDES:

Discrete output module.....(1)

■ MODEL NO.

Confirm Model No. marking on the product to be exactly what you ordered.

■ INSTRUCTION MANUAL

This manual describes necessary points of caution when you use this product, including installation, connection and basic maintenance procedures.

POINTS OF CAUTION**■ CONFORMITY WITH EU DIRECTIVES**

- The equipment must be mounted inside the instrument panel of a metal enclosure.
- The actual installation environments such as panel configurations, connected devices, connected wires, may affect the protection level of this unit when it is integrated in a panel system. The user may have to review the CE requirements in regard to the whole system and employ additional protective measures to ensure the CE conformity.

■ HOT SWAPPABLE MODULES

- Replacing the module does not affect other modules on the same base. Thus, the module can be replaced while the power is ON. However, replacing multiple modules at once may greatly change live voltage levels. We highly recommend to replace them one by one.

■ GENERAL PRECAUTIONS

- DO NOT set the switches on the module while the power is supplied. The switches are used only for maintenance without the power.

■ ENVIRONMENT

- Indoor use.
- When heavy dust or metal particles are present in the air, install the unit inside proper housing with sufficient ventilation.
- Do not install the unit where it is subjected to continuous vibration. Do not subject the unit to physical impact.
- Environmental temperature must be within -10 to +55°C (14 to 131°F) with relative humidity within 30 to 90% RH in order to ensure adequate life span and operation.

■ WIRING

- Do not install cables close to noise sources (relay drive cable, high frequency line, etc.).
- Do not bind these cables together with those in which noises are present. Do not install them in the same duct.

■ AND

- The unit is designed to function as soon as power is supplied, however, a warm up for 10 minutes is required for satisfying complete performance described in the data sheet.

INSTALLATION

Use the Installation Base (model: R3-BSx).

COMPONENT IDENTIFICATION

■ FRONT VIEW

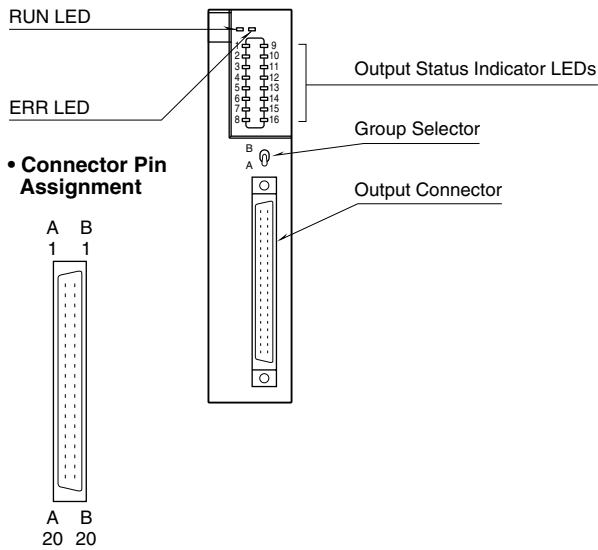

■ SIDE VIEW

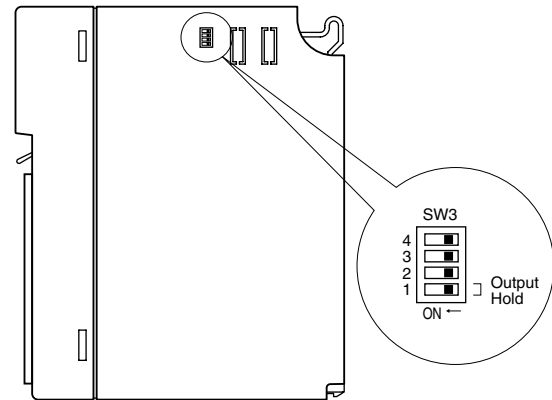

■ STATUS INDICATOR LED

RUN indicator: Bi-color (red/green) LED;
 Red when the bus A operates normally;
 Green when the bus B operates normally;
 Amber when both buses operate normally.

ERR indicator: Green LED turns on in normal operating conditions.

Output status indicator: Red LED; turns on with the output ON.

■ GROUP SELECTOR

Switches the output status indicator.

A. 1 – 8: Do 11 – Do 18

9 – 16: Do 21 – Do 28

B. 1 – 8: Do 31 – Do 38

9 – 16: Do 41 – Do 48

■ SIDE DIP SW

• Output Hold: SW3-1

SW	OUTPUT HOLD	
	HOLD (*)	OFF
SW3-1	OFF	ON

(*) Factory setting

Note: Be sure to set unused SW3-2 through 3-4 to OFF.

TERMINAL CONNECTIONS

Connect the unit as in the diagram below.

■ EXTERNAL DIMENSIONS unit: mm (inch)

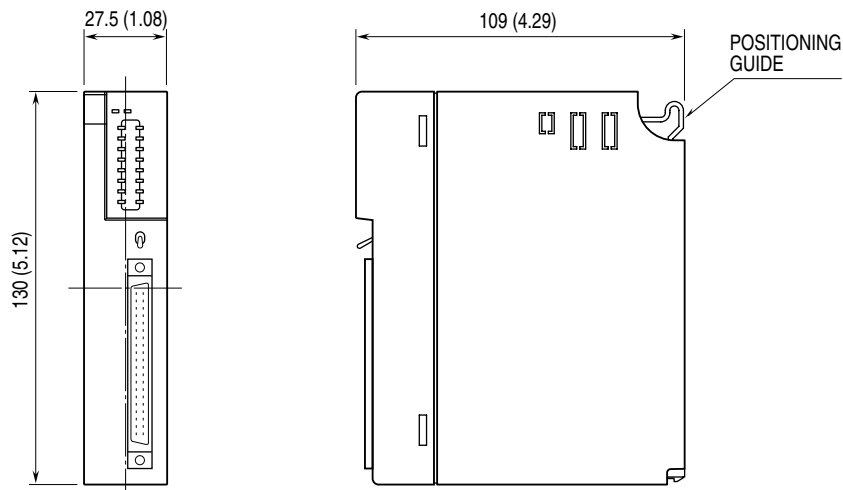

CONNECTION DIAGRAM

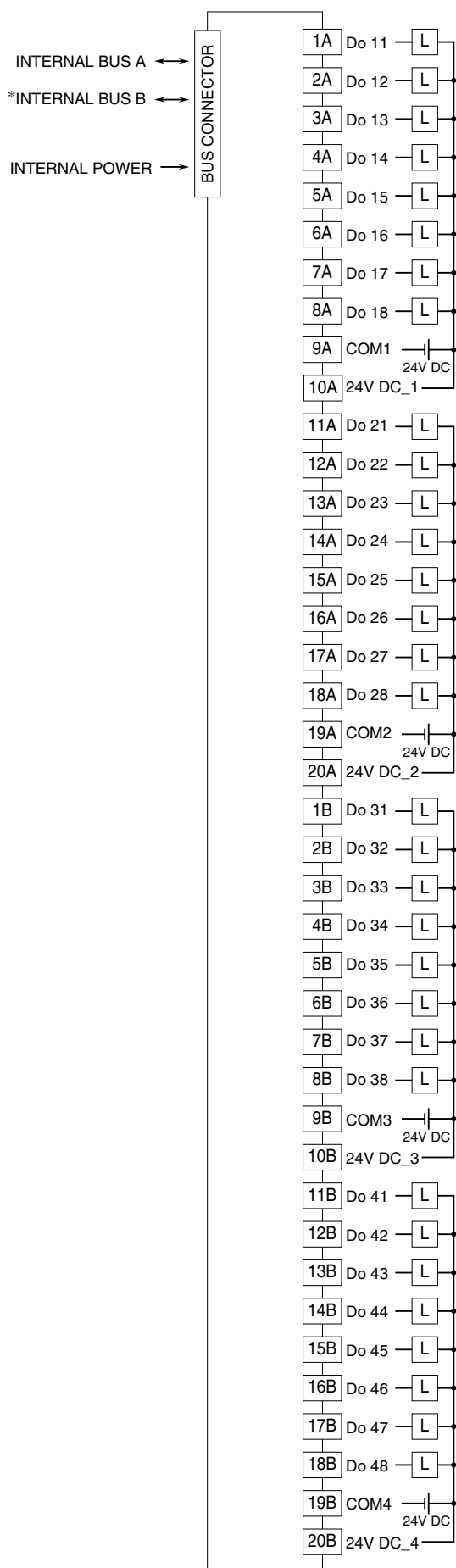

*For dual redundant communication.

OUTPUT CONNECTOR (40 pins)

PIN NO.	ASSIGNMENT	PIN NO.	ASSIGNMENT
1A	Do 11	1B	Do 31
2A	Do 12	2B	Do 32
3A	Do 13	3B	Do 33
4A	Do 14	4B	Do 34
5A	Do 15	5B	Do 35
6A	Do 16	6B	Do 36
7A	Do 17	7B	Do 37
8A	Do 18	8B	Do 38
9A	COM1	9B	COM3
10A	24V DC_1	10B	24V DC_3
11A	Do 21	11B	Do 41
12A	Do 22	12B	Do 42
13A	Do 23	13B	Do 43
14A	Do 24	14B	Do 44
15A	Do 25	15B	Do 45
16A	Do 26	16B	Do 46
17A	Do 27	17B	Do 47
18A	Do 28	18B	Do 48
19A	COM2	19B	COM4
20A	24V DC_2	20B	24V DC_4

FUNCTIONS

OUTPUT HOLD or OUTPUT OFF

In normal conditions, the module outputs the signal from the preferred bus A.

When an error is detected, the output is switched to the data from the bus B.

• Output Hold

If both are in error, the module holds the signal and stands by until one of the communications recovers.

• Output OFF

If both are in error, the module outputs OFF signals and stands by until one of the communications recovers.

At the startup, it outputs OFF until the communication is established and normal data is received.