

DISCRETE INPUT OUTPUT MODULE

(Di 8 points, Do 8 points)

MODEL **R3-DAC16**

BEFORE USE

Thank you for choosing M-System. Before use, please check contents of the package you received as outlined below.

If you have any problems or questions with the product, please contact M-System's Sales Office or representatives.

■ PACKAGE INCLUDES:

Discrete input output module.....(1)

■ MODEL NO.

Confirm Model No. marking on the product to be exactly what you ordered.

■ INSTRUCTION MANUAL

This manual describes necessary points of caution when you use this product, including installation, connection and basic maintenance procedures.

POINTS OF CAUTION

■ CONFORMITY WITH EU DIRECTIVES

- The equipment must be mounted inside the instrument panel of a metal enclosure.
- The actual installation environments such as panel configurations, connected devices, connected wires, may affect the protection level of this unit when it is integrated in a panel system. The user may have to review the CE requirements in regard to the whole system and employ additional protective measures to ensure the CE conformity.

■ HOT SWAPPABLE MODULES

- Replacing the module does not affect other modules on the same base. Thus, the module can be replaced while the power is ON. However, replacing multiple modules at once may greatly change live voltage levels. We highly recommend to replace them one by one.
- ON/OFF control output mode and One-shot output mode have the function of preventing erroneous output right after hot swapping modules. Data is synchronized with data stored in the interface module in the initial communication after hot swapping.

Data will not be output from a channel even if '1' is previously written in Do before hot swapping or the PLC/PC writes '1' to Do when communication has started after hot swapping. Be sure to write '0' then '1' to Do in the initial communication.

When R3-DAC16 is used in combination with a Modbus interface module (model: R3-NM1, R3-NE1, etc.) that does not support cyclic communication, be sure to write output data immediately before hot swapping.

■ GENERAL PRECAUTIONS

- DO NOT set the switches on the module while the power is supplied. The switches are used only for maintenance without the power.

■ ENVIRONMENT

- Indoor use.
- When heavy dust or metal particles are present in the air, install the unit inside proper housing with sufficient ventilation.
- Do not install the unit where it is subjected to continuous vibration. Do not subject the unit to physical impact.
- Environmental temperature must be within -10 to +55°C (14 to 131°F) with relative humidity within 30 to 90% RH in order to ensure adequate life span and operation.

■ WIRING

- Do not install cables close to noise sources (relay drive cable, high frequency line, etc.).
- Do not bind these cables together with those in which noises are present. Do not install them in the same duct.

■ AND

- This unit is not designed to be used with the following types of interface modules (models: R3-NC2, R3-NEIP1, R3-NFx, R3-NLx).
- Output completion status data is compatible with interface modules (models: R3-NC1, R3-NC3, R3-NDx, R3-NE1, R3-NFL1, R3-NM1, R3-NM4, R3-NP1) of firmware version V2.00 or higher, and interface modules (models: R3-NM3, R3-NML3) of firmware version V1.00 or higher.
- When the pause period set in the PLC/PC is long, internal data of R3-DAC16 will be cleared due to communication timeout. In order to hold the internal data, set the timeout period so as to be longer than the pause period via the PC configurator software (model:R3CON).

INSTALLATION

Use the Installation Base (model: R3-BSx).

COMPONENT IDENTIFICATION

FRONT VIEW

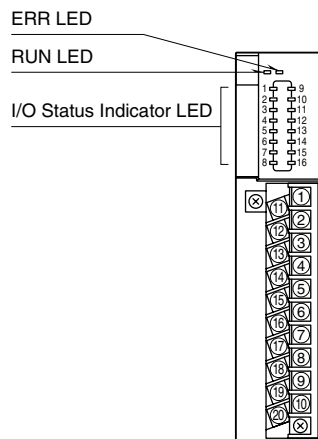

SIDE VIEW

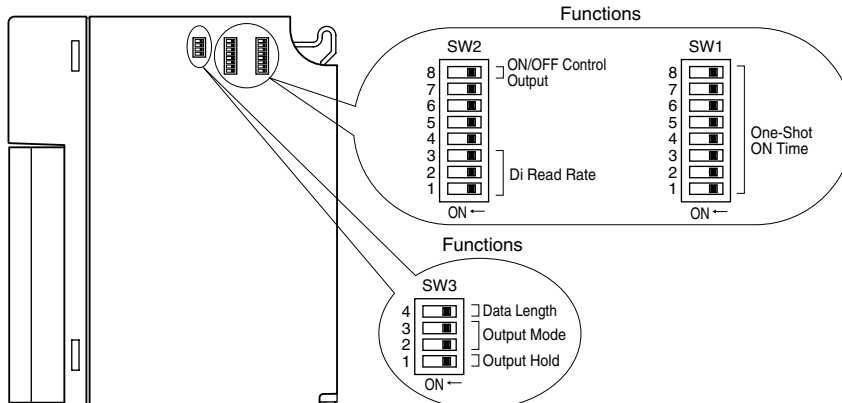

STATUS INDICATOR LED

RUN indicator: Bi-color (red/green) LED;
 Red when the bus A operates normally;
 Green when the bus B operates normally;
 Amber when both buses operate normally.

ERR indicator: Bi-color (red/green) LED;
 Red in error conditions;
 Green in normal operating conditions.

I/O status indicator: Red LED

- 1 – 8: Input status, turns on with the inputs ON.
- 9 – 16: Output status, turns on with the outputs ON.

SIDE DIP SW

(*) Factory setting

One-Shot ON Time: SW1-1 through 1-8

For setting Output ON time, DIP switch 1 through 8 correspond to each binary digit 1st through 8th digit. For every setting, ON time will be as indicated below.

SW	ONE-SHOT ON TIME (sec.)							
	0.1 (*)	0.2	0.3	0.4	0.5	...	25.5	25.6
SW1-1	OFF	ON	OFF	ON	OFF	...	OFF	ON
SW1-2	OFF	OFF	ON	ON	OFF		ON	ON
SW1-3	OFF	OFF	OFF	OFF	ON		ON	ON
SW1-4	OFF	OFF	OFF	OFF	OFF		ON	ON
SW1-5	OFF	OFF	OFF	OFF	OFF		ON	ON
SW1-6	OFF	OFF	OFF	OFF	OFF		ON	ON
SW1-7	OFF	OFF	OFF	OFF	OFF		ON	ON
SW1-8	OFF	OFF	OFF	OFF	OFF		ON	ON

Di Read Rate: SW2-1 through 2-3

SW	Di READ RATE (≤ msec)							
	10 (*)	1	5	20	50	70	100	200
SW2-1	OFF	ON	OFF	ON	OFF	ON	OFF	ON
SW2-2	OFF	OFF	ON	ON	OFF	OFF	ON	ON
SW2-3	OFF	OFF	OFF	OFF	ON	ON	ON	ON

ON/OFF Control Output: SW2-8

ON/OFF control output is swappable with its pair.

SW	ON/OFF CONTROL OUTPUT	
	Not Swapped	Swapped
SW2-8	OFF (*)	ON

Output Hold: SW3-1

Effective only in continuous output mode.

SW	OUTPUT HOLD	
	HOLD (*)	OFF
SW3-1	OFF	ON

Output Mode: SW3-2, 3-3

SW		OUTPUT MODE
SW3-2	SW3-3	
OFF	OFF	One-Shot Output Mode (*)
ON	OFF	ON/OFF Control Output Mode
OFF	ON	Continuous Output Mode

Data Length: SW3-4

Effective only in ON/OFF control output mode.

SW	DATA LENGTH	
	8 bit	4 bit
SW3-4	OFF (*)	ON

Note: Be sure to set unused SW2-4 through 2-7 to OFF.

EXAMPLE OF OPERATION MODES

■ **ONE-SHOT OUTPUT MODE** (1 through 4 show changes after Do 1 is completed. 5 through 10 changes Do 1 during output state.)

- (1) Output data Do 1 changes from 0 to 1.
- (2) After Do 1's rising edge, Ch1's one-shot output turns ON for a fixed period of time (SW1's time set).
- (3) After one-shot output completion, Di 9 (Ch1 output completed status) changes from 0 to 1.
- (4) When Do 1 changes from 1 to 0, Di 9 changes from 1 to 0.
- (5) Output Data Do 1 changes from 0 to 1 again.
- (6) After Do 1's rising edge, Ch1's one-shot output turns ON for a fixed period of time (SW1's time set).
- (7) (8) (9) During one-shot output is ON, Do 1 changes from 0 to 1 to 0.
- (10) Since Do 1 changes to 0 during one-shot output is 1, Di 9 (Ch1 output completion status) doesn't change.

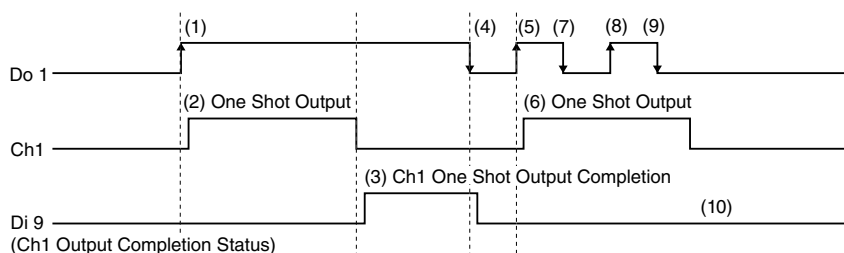

Note: During one shot output is on, rising edge and sinking edge are not detected.

■ ON/OFF CONTROL OUTPUT MODE

• Data Length: 8 bits

Example that ON/OFF control outputs sequentially Ch1 to Ch2 to Ch2 is shown below. (SW2-8 is OFF: Not Swapped)

- (1) Output data Do 1 changes from 0 to 1.
- (2) After Do 1's rising edge, Ch1's one-shot output turns ON for a fixed period of time (SW1's time set).
- (3) After one-shot output completion, Di 9 (Ch1 output completed status) changes from 0 to 1.
- (4) Do 1 changes from 1 to 0.
- (5) When output data Do 2 changes from 0 to 1, Di 9 will change from 1 to 0.
- (6) After Do 2's rising edge, Ch2's one-shot output turns ON for a fixed period of time (SW1's time set).
- (7) After Ch2's one-shot output completion, Di 10 changes from 0 to 1.
- (8) When Do 1 changes 0 to 1 during Do 2 is 1, Di 10 changes 1 to 0 (output data reset).
- (9) Do 1 changes from 1 to 0.
- (10) After Do 1's sinking edge, Ch2's one-shot output turns ON for a fixed period of time (SW1's time set).
- (11) After Ch2's one-shot output completion, Di 10 changes from 0 to 1.

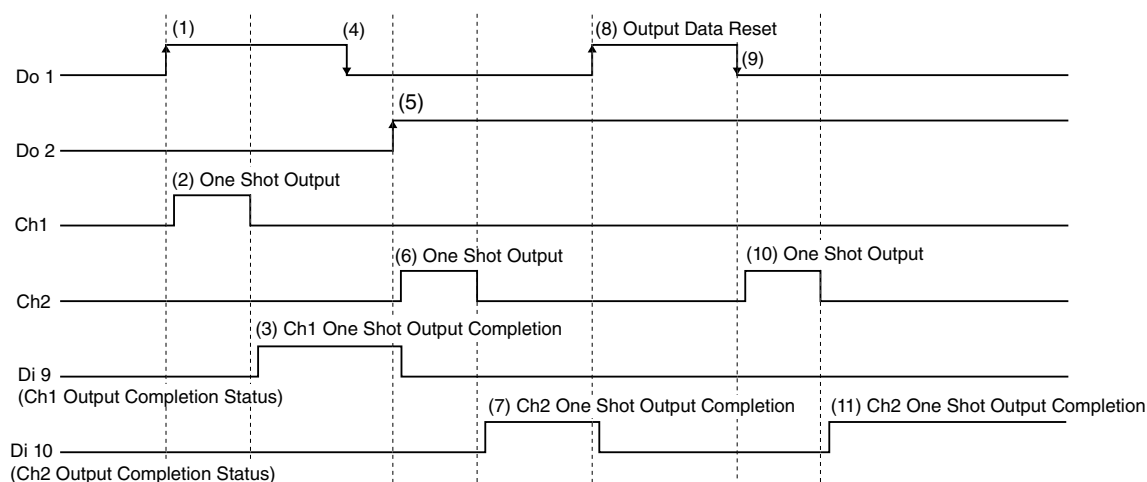

Note: During one shot output is on, rising edge and sinking edge are not detected.

• Data Length: 4 bits

Example that ON/OFF control outputs sequentially Ch2 to Ch1 is shown below. (SW2-8 is OFF: Not Swapped)

- (1) Output data Do 1 changes from 0 to 1.
- (2) After Do 1's rising edge, Ch2's one-shot output turns ON for a fixed period of time (SW1's time set).
- (3) After one-shot output completion, Di 10 (Ch2 output completed status) changes from 0 to 1.
- (4) When Do 1 changes from 1 to 0, Di 10 changes from 1 to 0.
- (5) After Do 1's sinking edge, Ch1's one-shot output turns ON for a fixed period of time (SW1's time set).
- (6) After one-shot output completion, Di 9 (Ch1 output completed status) changes from 0 to 1.

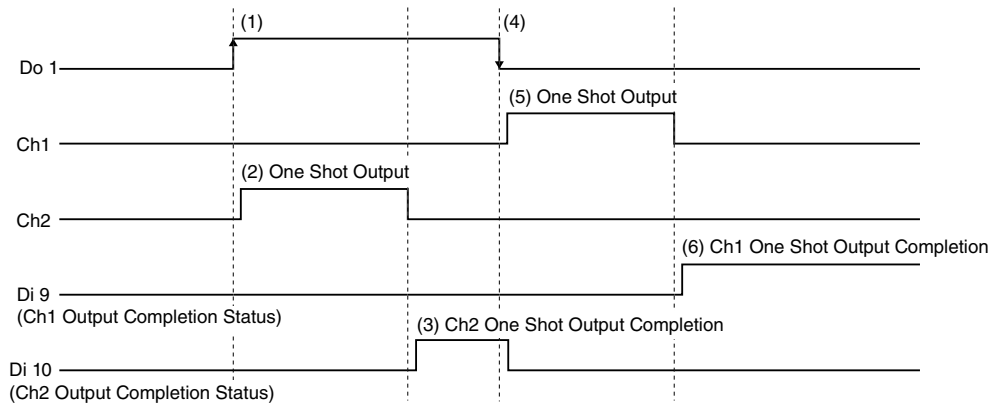

Note: During one shot output is on, rising edge and sinking edge are not detected.

■ CONTINUOUS OUTPUT MODE

Example of Ch1 is shown below.

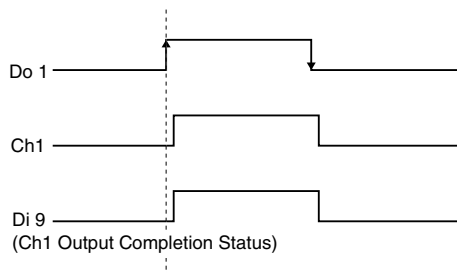

I/O DATA DESCRIPTIONS

■ ONE-SHOT OUTPUT MODE

8-bit output data (Do 1 through 8) and output (Ch1 through 8) are assigned 1:1.

Do	WRITE	ONE-SHOT OUTPUT/RESET	Di	OUTPUT COMPLETION STATUS
Do 1	1	Ch1 Output	Di 9	Ch1 Output Completion Status
	0	Ch1 Output Completion Reset		
Do 2	1	Ch2 Output	Di 10	Ch2 Output Completion Status
	0	Ch2 Output Completion Reset		
Do 3	1	Ch3 Output	Di 11	Ch3 Output Completion Status
	0	Ch3 Output Completion Reset		
Do 4	1	Ch4 Output	Di 12	Ch4 Output Completion Status
	0	Ch4 Output Completion Reset		
Do 5	1	Ch5 Output	Di 13	Ch5 Output Completion Status
	0	Ch5 Output Completion Reset		
Do 6	1	Ch6 Output	Di 14	Ch6 Output Completion Status
	0	Ch6 Output Completion Reset		
Do 7	1	Ch7 Output	Di 15	Ch7 Output Completion Status
	0	Ch7 Output Completion Reset		
Do 8	1	Ch8 Output	Di 16	Ch8 Output Completion Status
	0	Ch8 Output Completion Reset		

■ ON/OFF CONTROL OUTPUT MODE

• Data Length: 8 bits

Do 1 through 8 are assigned to Ch1 through 8.

Do	WRITE	ONE-SHOT OUTPUT/RESET	Di	OUTPUT COMPLETION STATUS
Do 1 Do 2	0 0	Not Operating		
	1 0	Ch1 Output	Di 9	Ch1 Output Completion Status
	0 1	Ch2 Output	Di 10	Ch2 Output Completion Status
	1 1	Output Data Reset		
Do 3 Do 4	0 0	Not Operating		
	1 0	Ch3 Output	Di 11	Ch3 Output Completion Status
	0 1	Ch4 Output	Di 12	Ch4 Output Completion Status
	1 1	Output Data Reset		
Do 5 Do 6	0 0	Not Operating		
	1 0	Ch5 Output	Di 13	Ch5 Output Completion Status
	0 1	Ch6 Output	Di 14	Ch6 Output Completion Status
	1 1	Output Data Reset		
Do 7 Do 8	0 0	Not Operating		
	1 0	Ch7 Output	Di 15	Ch7 Output Completion Status
	0 1	Ch8 Output	Di 16	Ch8 Output Completion Status
	1 1	Output Data Reset		

The above table shows the case of Not Swapped (SW2-8: OFF). ON/OFF control output is swapped with its pair when SW2-8 is ON. The following is an example of Do 1 and Do 2.

Do	WRITE	ONE-SHOT OUTPUT/RESET	Di	OUTPUT COMPLETION STATUS
Do 1 Do 2	0 0	Not Operating		
	1 0	Ch2 Output	Di 10	Ch2 Output Completion Status
	0 1	Ch1 Output	Di 9	Ch1 Output Completion Status
	1 1	Output Data Reset		

• **Data Length: 4 bits**

Do 1 through 4 are assigned to Ch1 through 8 as 1:2.

Do	WRITE	ONE-SHOT OUTPUT/RESET	Di	OUTPUT COMPLETION STATUS
Do 1	0	Ch1 Output	Di 9	Ch1 Output Completion Status
	1	Ch2 Output	Di 10	Ch2 Output Completion Status
Do 2	0	Ch3 Output	Di 11	Ch3 Output Completion Status
	1	Ch4 Output	Di 12	Ch4 Output Completion Status
Do 3	0	Ch5 Output	Di 13	Ch5 Output Completion Status
	1	Ch6 Output	Di 14	Ch6 Output Completion Status
Do 4	0	Ch7 Output	Di 15	Ch7 Output Completion Status
	1	Ch8 Output	Di 16	Ch8 Output Completion Status

The above table shows the case of Not Swapped (SW2-8: OFF). ON/OFF control output is swapped with its pair when SW2-8 is ON. The following is an example of Do 1.

Do	WRITE	ONE-SHOT OUTPUT/RESET	Di	OUTPUT COMPLETION STATUS
Do 1	0	Ch2 Output	Di 10	Ch2 Output Completion Status
	1	Ch1 Output	Di 9	Ch1 Output Completion Status

■ **CONTINUOUS OUTPUT MODE**

Do 1 through 8 are assigned to and Ch1 through 8. When data Do is “1” output is ON (energized) and when it is “0” output is OFF (de-energized). The operation is equivalent to 16 points discrete output module (model: R3-DC16). Output completion status Di is related to Do.

Do	CONTINUOUS OUTPUT	Di	OUTPUT COMPLETION STATUS
Do 1	Ch1 Output	Di 9	Ch1 Output Completion Status
Do 2	Ch2 Output	Di 10	Ch2 Output Completion Status
Do 3	Ch3 Output	Di 11	Ch3 Output Completion Status
Do 4	Ch4 Output	Di 12	Ch4 Output Completion Status
Do 5	Ch5 Output	Di 13	Ch5 Output Completion Status
Do 6	Ch6 Output	Di 14	Ch6 Output Completion Status
Do 7	Ch7 Output	Di 15	Ch7 Output Completion Status
Do 8	Ch8 Output	Di 16	Ch8 Output Completion Status

DATA ASSIGNMENT

■ Do

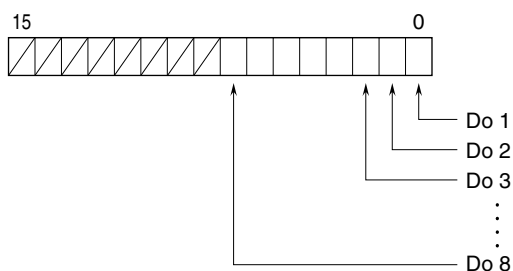

Note 1: For 4-bit length ON/OFF control mode, Do 5 through Do 8 are unavailable.

Note 2: For the combination with Modbus communication module (model: R3-NE1, R3-NM1 and such), use the addresses of Coil (0X) for Modbus I/O assignment.

■ Di

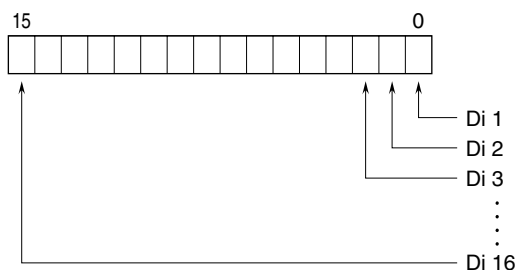

Note 1: Di 9 – 16 data is not practical discrete input data. It is “output completion status” internal data.

Note 2: For the combination with Modbus communication module (model: R3-NE1, R3-NM1 and such), use the addresses of Input (1X) for Modbus I/O assignment.

TERMINAL CONNECTIONS

Connect the unit as in the diagram below.

■ EXTERNAL DIMENSIONS unit: mm (inch)

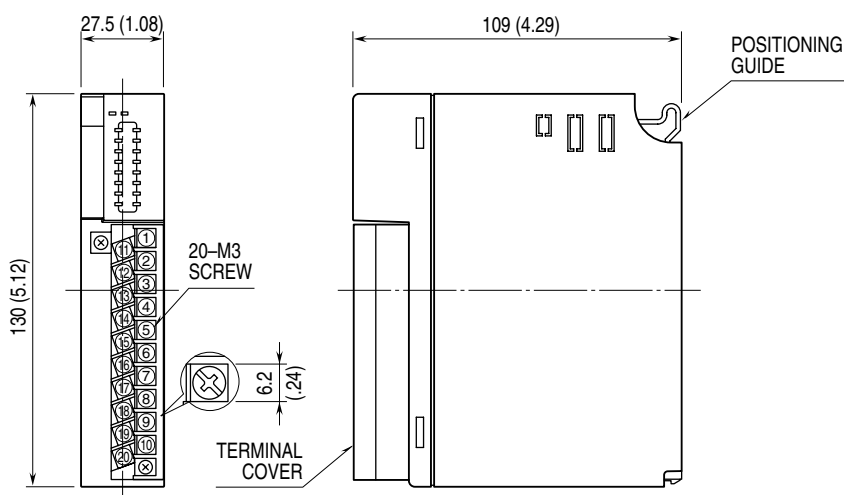

CONNECTION DIAGRAM

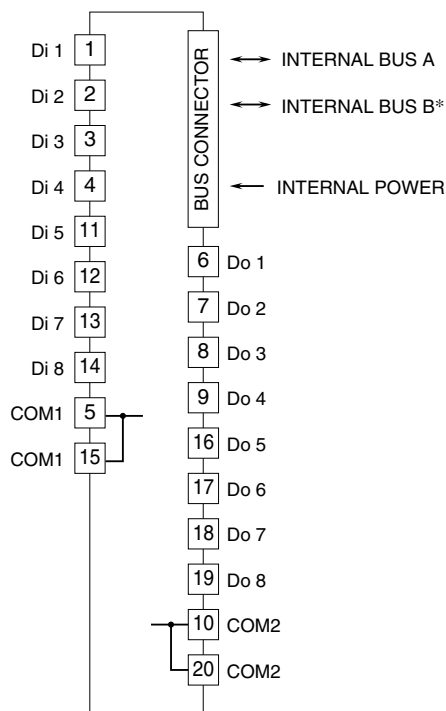

*For dual redundant communication.

FUNCTIONS

OUTPUT HOLD or OUTPUT OFF

In normal conditions, the module outputs the signal from the preferred bus A.

When an error is detected, the output is switched to the data from the bus B.

• Output Hold

If both are in error, the module holds the signal and stands by until one of the communications recovers.

• Output OFF

If both are in error, the module outputs OFF signals and stands by until one of the communications recovers.

At the startup, it outputs OFF until the communication is established and normal data is received.

WIRING INSTRUCTIONS

SCREW TERMINAL

Torque: 0.5 N·m

SOLDERLESS TERMINAL

Refer to the drawing below for recommended ring tongue terminal size. Spade tongue type is also applicable. Solderless terminals with insulation sleeve do not fit.

Applicable wire size: 0.3 – 0.5 mm²

Recommended manufacturer: Japan Solderless Terminal MFG. Co., Ltd., Nichifu Co., Ltd.

