

**DISCRETE INPUT MODULE**  
(Di 32 points; with external excitation supply)MODEL **R3-DA32A****BEFORE USE ....**

Thank you for choosing M-System. Before use, please check contents of the package you received as outlined below.

If you have any problems or questions with the product, please contact M-System's Sales Office or representatives.

**■ PACKAGE INCLUDES:**

Discrete input module.....(1)

**■ MODEL NO.**

Confirm Model No. marking on the product to be exactly what you ordered.

**■ INSTRUCTION MANUAL**

This manual describes necessary points of caution when you use this product, including installation, connection and basic maintenance procedures.

**POINTS OF CAUTION****■ CONFORMITY WITH EU DIRECTIVES**

- The equipment must be mounted inside the instrument panel of a metal enclosure.
- The actual installation environments such as panel configurations, connected devices, connected wires, may affect the protection level of this unit when it is integrated in a panel system. The user may have to review the CE requirements in regard to the whole system and employ additional protective measures to ensure the CE conformity.

**■ HOT SWAPPABLE MODULES**

- Replacing the module does not affect other modules on the same base. Thus, the module can be replaced while the power is ON. However, replacing multiple modules at once may greatly change live voltage levels. We highly recommend to replace them one by one.

**■ GENERAL PRECAUTIONS**

- DO NOT set the switches on the module while the power is supplied. The switches are used only for maintenance without the power.

**■ ENVIRONMENT**

- Indoor use.
- When heavy dust or metal particles are present in the air, install the unit inside proper housing with sufficient ventilation.
- Do not install the unit where it is subjected to continuous vibration. Do not subject the unit to physical impact.
- Environmental temperature must be within -10 to +55°C (14 to 131°F) with relative humidity within 30 to 90% RH in order to ensure adequate life span and operation.

**■ WIRING**

- Do not install cables close to noise sources (relay drive cable, high frequency line, etc.).
- Do not bind these cables together with those in which noises are present. Do not install them in the same duct.

**INSTALLATION**

Use the Installation Base (model: R3-BSx).

## COMPONENT IDENTIFICATION

### FRONT VIEW

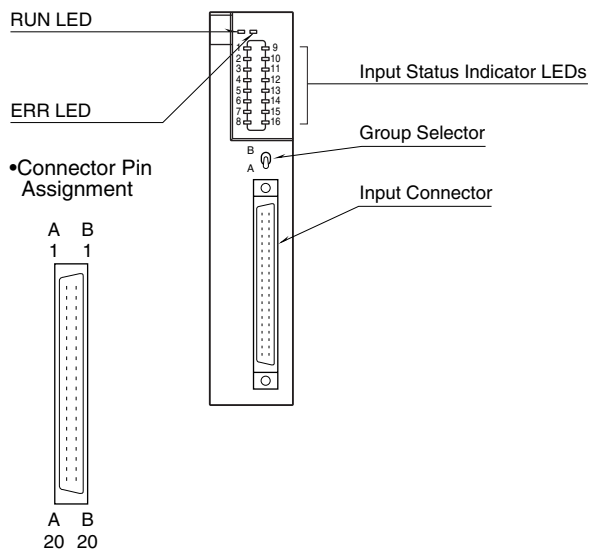

### SIDE VIEW

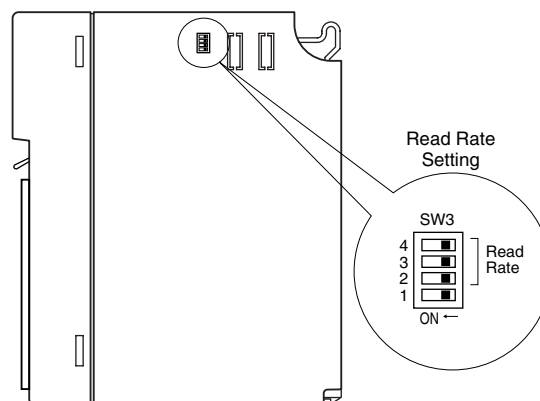

### STATUS INDICATOR LED

**RUN indicator:** Bi-color (red/green) LED;  
 Red when the bus A operates normally;  
 Green when the bus B operates normally;  
 Amber when both buses operate normally.

**ERR indicator:** Green LED turns on in normal operating conditions.

**Input status indicator:** Red LED; turns on with the input ON.

### GROUP SELECTOR

Switches the input status indicator.

**A. 1 – 8:** Di 11 – Di 18

**9 – 16:** Di 21 – Di 28

**B. 1 – 8:** Di 31 – Di 38

**9 – 16:** Di 41 – Di 48

### SIDE DIP SW

#### • Read Rate: SW3-2, 3-3, 3-4

SW	READ RATE ( $\leq$ msec.)							
	10 (*)	1	5	20	50	70	100	200
SW3-2	OFF	ON	OFF	ON	OFF	ON	OFF	ON
SW3-3	OFF	OFF	ON	ON	OFF	OFF	ON	ON
SW3-4	OFF	OFF	OFF	OFF	ON	ON	ON	ON

(\*) Factory setting

Note: Be sure to set unused SW3-1 to OFF.

## TERMINAL CONNECTIONS

Connect the unit as in the diagram below.

### EXTERNAL DIMENSIONS unit: mm (inch)

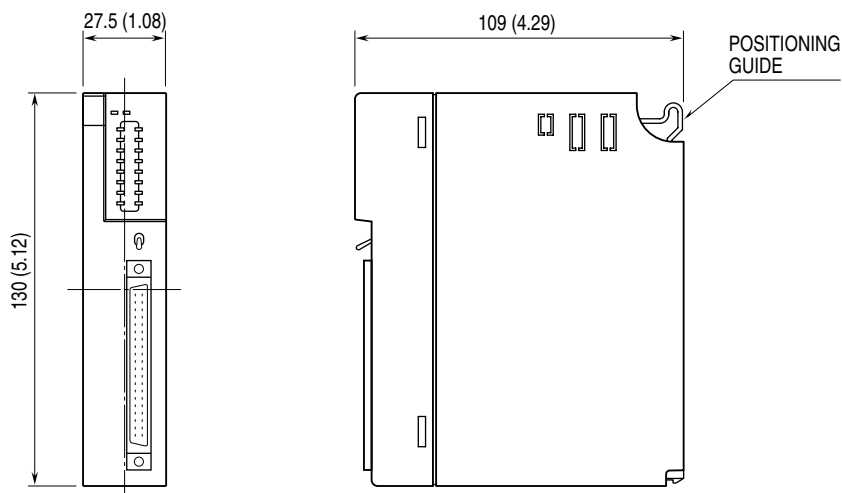

CONNECTION DIAGRAM

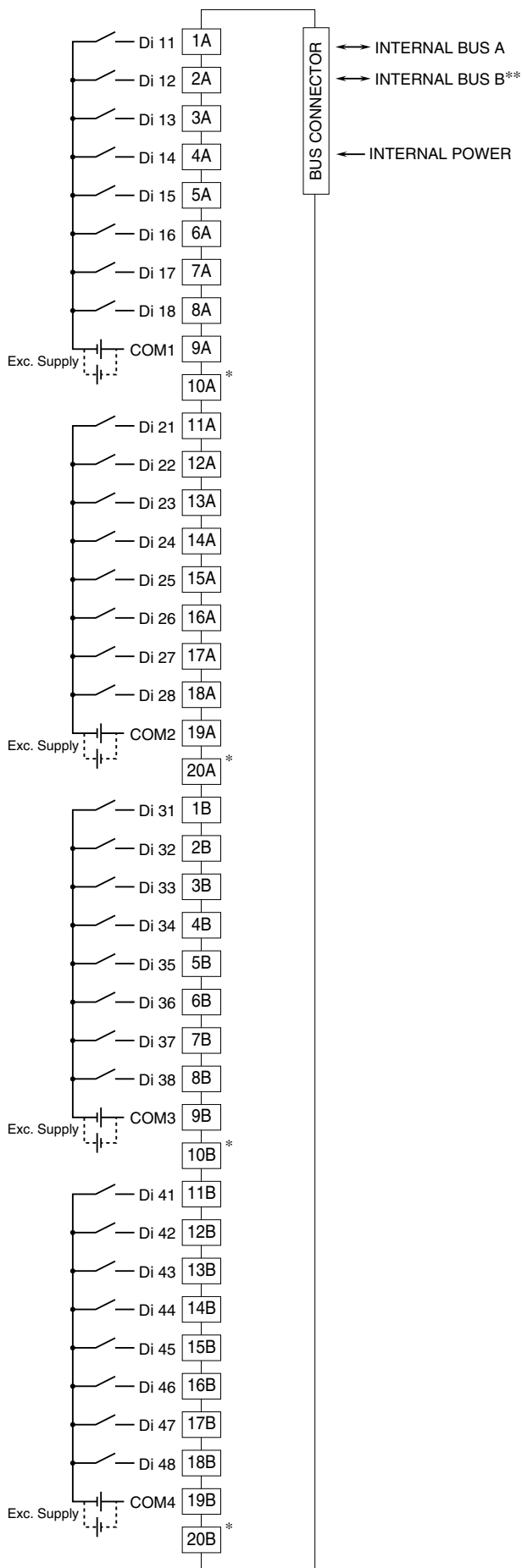

Input Connection Examples

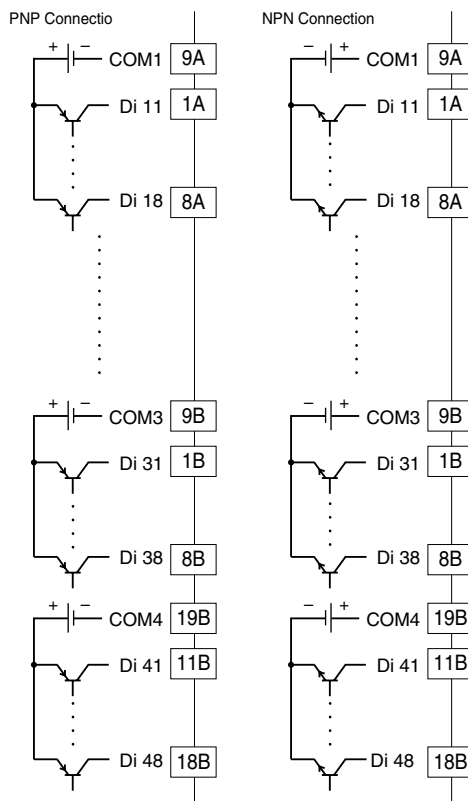

\* Do not use pins 10A, 20A, 10B, 20B.

\*\*For dual redundant communication.

**INPUT CONNECTOR (40 pins)**

PIN NO.	ASSIGNMENT	PIN NO.	ASSIGNMENT
1A	Di 11	1B	Di 31
2A	Di 12	2B	Di 32
3A	Di 13	3B	Di 33
4A	Di 14	4B	Di 34
5A	Di 15	5B	Di 35
6A	Di 16	6B	Di 36
7A	Di 17	7B	Di 37
8A	Di 18	8B	Di 38
9A	COM1	9B	COM3
10A	No Connection	10B	No Connection
11A	Di 21	11B	Di 41
12A	Di 22	12B	Di 42
13A	Di 23	13B	Di 43
14A	Di 24	14B	Di 44
15A	Di 25	15B	Di 45
16A	Di 26	16B	Di 46
17A	Di 27	17B	Di 47
18A	Di 28	18B	Di 48
19A	COM2	19B	COM4
20A	No Connection	20B	No Connection