

DC VOLTAGE INPUT ALARM MODULE

(8 points, isolated)

MODEL **R3-AV8**

BEFORE USE

Thank you for choosing M-System. Before use, please check contents of the package you received as outlined below.

If you have any problems or questions with the product, please contact M-System's Sales Office or representatives.

■ PACKAGE INCLUDES:

DC voltage input alarm module(1)

■ MODEL NO.

Confirm Model No. marking on the product to be exactly what you ordered.

■ INSTRUCTION MANUAL

This manual describes necessary points of caution when you use this product, including installation, connection and basic maintenance procedures.

POINTS OF CAUTION

■ CONFORMITY WITH EU DIRECTIVES

- The equipment must be mounted inside the instrument panel of a metal enclosure.
- The actual installation environments such as panel configurations, connected devices, connected wires, may affect the protection level of this unit when it is integrated in a panel system. The user may have to review the CE requirements in regard to the whole system and employ additional protective measures to ensure the CE conformity.

■ HOT SWAPPABLE MODULES

- Replacing the module does not affect other modules on the same base. Thus, the module can be replaced while the power is ON. However, replacing multiple modules at once may greatly change live voltage levels. We highly recommend to replace them one by one.

■ GENERAL PRECAUTIONS

- DO NOT set the switches on the module while the power is supplied. The switches are used only for maintenance without the power.

■ ENVIRONMENT

- Indoor use.
- When heavy dust or metal particles are present in the air, install the unit inside proper housing with sufficient ventilation.
- Do not install the unit where it is subjected to continuous vibration. Do not subject the unit to physical impact.
- Environmental temperature must be within -10 to +55°C (14 to 131°F) with relative humidity within 30 to 90% RH in order to ensure adequate life span and operation.

■ WIRING

- Do not install cables close to noise sources (relay drive cable, high frequency line, etc.).
- Do not bind these cables together with those in which noises are present. Do not install them in the same duct.

■ UNUSED INPUT CHANNELS

- Set the unused input channels to $\pm 10V$ range. Unused channels left open with other settings may be equal to the input lower than -15%, which sets a data abnormality at the PLC or the host device.
- Open circuit with the input range set to $\pm 10V$ means 50% of the full-scale. An alarm setpoint must be set to a value that does not trip an unwanted alarm.
- Unused channels can be specified and set so on the PC Configurator Software (model: R3CON) without needing the above mentioned setting.

■ AND

- The unit is designed to function as soon as power is supplied, however, a warm up for 10 minutes is required for satisfying complete performance described in the data sheet.

INSTALLATION

Use the Installation Base (model: R3-BSx).

COMPONENT IDENTIFICATION

■ SIDE VIEW

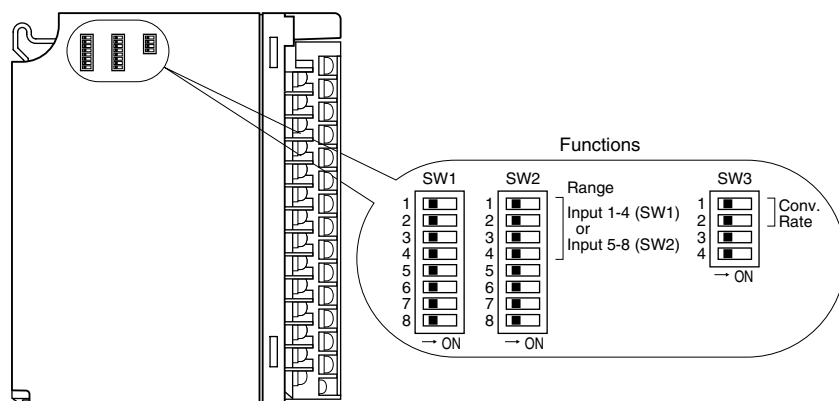

■ FRONT VIEW

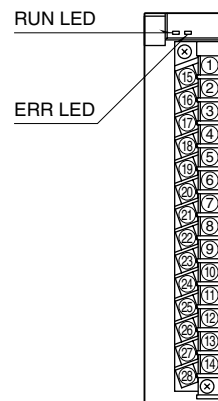

■ SIDE DIP SW

(*) Factory setting

• Input Range: SW1, SW2 (selectable per 4 channels)

INPUT 1 through INPUT 4 (SW1)				RANGE
1	2	3	4	
OFF	OFF	OFF	OFF	-10 – +10V (*)
ON	OFF	OFF	OFF	-5 – +5V
OFF	ON	OFF	OFF	-1 – +1V
ON	ON	OFF	OFF	0 – 10V
OFF	OFF	ON	OFF	0 – 5V
ON	OFF	ON	OFF	1 – 10V
OFF	ON	ON	OFF	0 – 1V

• Conversion Rate: SW3-1, 3-2

SW	CONVERSION RATE			
	160 ms (*)	80 ms	40 ms	20 ms
SW3-1	OFF	ON	OFF	ON
SW3-2	OFF	OFF	ON	ON

Note: Be sure to set unused SW1-5 through 1-8, SW2-5 through 2-8, SW3-3 and 3-4 to OFF.

■ STATUS INDICATOR LED

RUN indicator: Bi-color (red/green) LED;

Red when the bus A operates normally;
Green when the bus B operates normally;
Amber when both buses operate normally.

ERR indicator: Bi-color (red/green) LED;

Red with input circuit abnormality (AD converter response failure);
Green in normal operating conditions.

TERMINAL CONNECTIONS

Connect the unit as in the diagram below.

■ EXTERNAL DIMENSIONS unit: mm (inch)

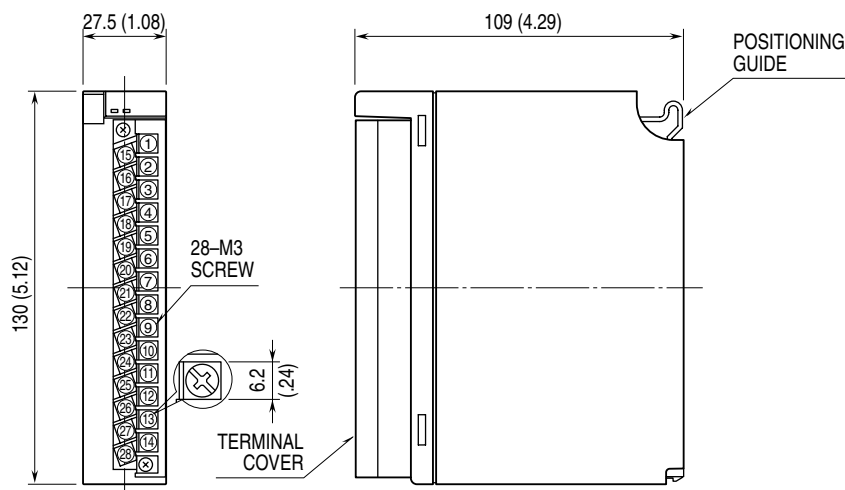

CONNECTION DIAGRAM

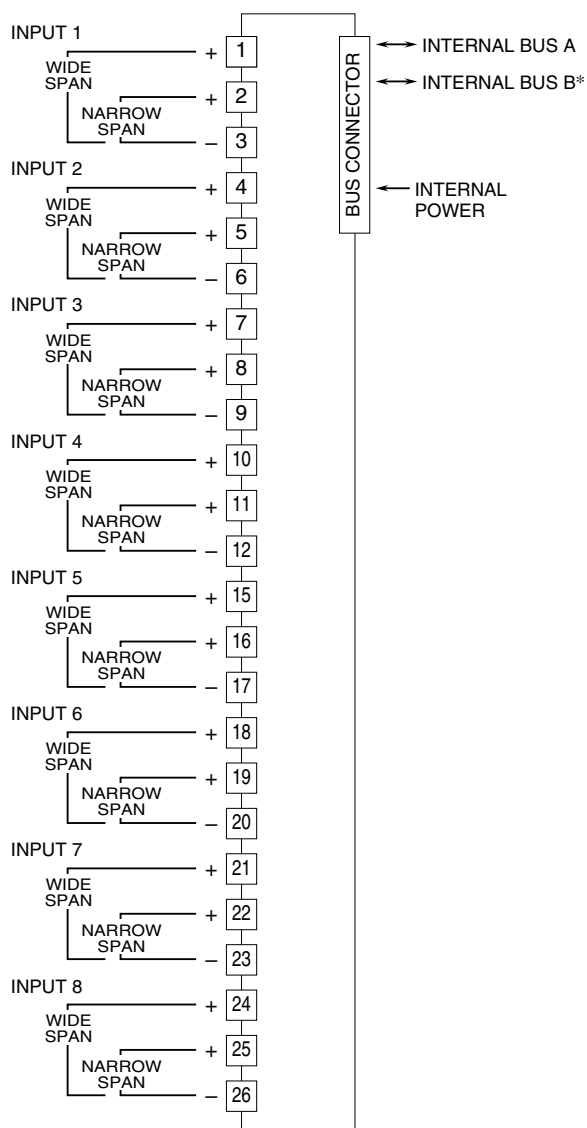

*For dual redundant communication.

Note: Connect either wide or narrow span terminals for each channel.

■ **Wide span** : -10 – +10 V DC, -5 – +5 V DC, 0 – 10 V DC, 0 – 5 V DC, 1 – 5 V DC

■ **Narrow span** : -1 – +1 V DC, 0 – 1 V DC

ALARM SETTING

The following parameters are programmable using the PC Configurator Software (model: R3CON).

■ **ALARM TRIP POINT (-15.00 to +115.00%; factory set to A1: 80.00, A2: 60.00, A3: 40.00, A4: 20.00)**

Four alarm setpoints are selectable per each input.

■ **ALARM TYPE (High or Low; factory set to A1: High, A2: High, A3: Low, A4: Low)**

High or Low alarm is selectable for each alarm trip point.
High alarm: An alarm is set when the input signal goes above the setpoint.

Low alarm: An alarm is set when the input signal goes below the setpoint.

■ **DEADBAND (HYSTERESIS) (0.00 to 100.00%; factory set to 5.00)**

Deadband (deviation between the points where the alarm is set and reset) is selectable for each alarm trip point.

■ **POWER ON DELAY TIME (0.0 to 99.0 seconds; factory set to 5.0)**

The alarm output start functioning in the preset time after the power has been turned on.

This setting is common to all four points.

■ **ALARM ON DELAY TIME (0.0 to 99.0 seconds; factory set to 1.0)**

The alarm output is set when the preset time elapses after the input has entered in the alarm range.

This setting is common to all four points.

■ **ALARM HOLD TIME (0.0 to 99.0 seconds; factory set to 1.0)**

The alarm output is held for the preset time even if it is reset in shorter time.

This setting is common to all four points.

OUTPUT DATA DESCRIPTIONS

Four alarm setpoints are selectable per each input. Two (2) word (16 bit × 2) data is transmitted to the PLC or the host device via the R3 network module.

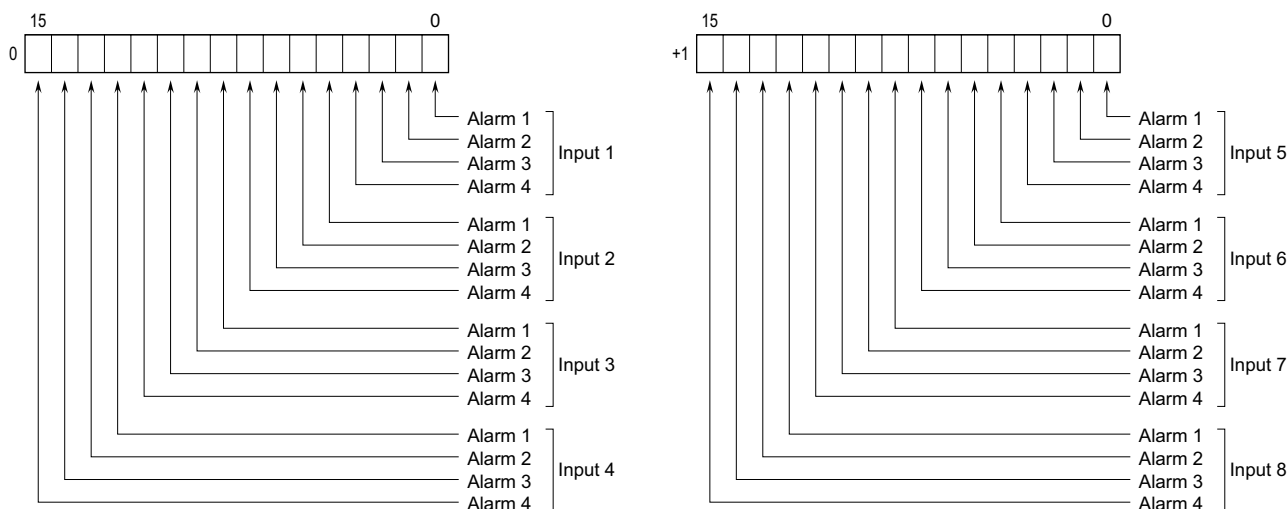

WIRING INSTRUCTIONS

■ SCREW TERMINAL

Torque: 0.5 N·m

■ SOLDERLESS TERMINAL

Refer to the drawing below for recommended ring tongue terminal size. Spade tongue type is also applicable. Solderless terminals with insulation sleeve do not fit.

Applicable wire size: 0.3 – 0.5 mm²

Recommended manufacturer: Japan Solderless Terminal MFG. Co., Ltd., Nichifu Co., Ltd.

