

BEFORE USE

Thank you for choosing M-System. Before use, please check contents of the package you received as outlined below.

If you have any problems or questions with the product, please contact M-System's Sales Office or representatives.

■ PACKAGE INCLUDES:

Thermocouple input alarm module.....(1)

■ MODEL NO.

Confirm Model No. marking on the product to be exactly what you ordered.

■ INSTRUCTION MANUAL

This manual describes necessary points of caution when you use this product, including installation, connection and basic maintenance procedures.

POINTS OF CAUTION**■ CONFORMITY WITH EU DIRECTIVES**

- The equipment must be mounted inside the instrument panel of a metal enclosure.
- The actual installation environments such as panel configurations, connected devices, connected wires, may affect the protection level of this unit when it is integrated in a panel system. The user may have to review the CE requirements in regard to the whole system and employ additional protective measures to ensure the CE conformity.

■ HOT SWAPPABLE MODULES

- Replacing the module does not affect other modules on the same base. Thus, the module can be replaced while the power is ON. However, replacing multiple modules at once may greatly change live voltage levels. We highly recommend to replace them one by one.

■ GENERAL PRECAUTIONS

- DO NOT set the switches on the module while the power is supplied. The switches are used only for maintenance without the power.

■ ENVIRONMENT

- Indoor use.
- When heavy dust or metal particles are present in the air, install the unit inside proper housing with sufficient ventilation.
- Do not install the unit where it is subjected to continuous vibration. Do not subject the unit to physical impact.
- Environmental temperature must be within -10 to +55°C (14 to 131°F) with relative humidity within 30 to 90% RH in order to ensure adequate life span and operation.

■ WIRING

- Do not install cables close to noise sources (relay drive cable, high frequency line, etc.).
- Do not bind these cables together with those in which noises are present. Do not install them in the same duct.

■ AND

- The unit is designed to function as soon as power is supplied, however, a warm up for 10 minutes is required for satisfying complete performance described in the data sheet.

INSTALLATION

Use the Installation Base (model: R3-BSx).

COMPONENT IDENTIFICATION

FRONT VIEW

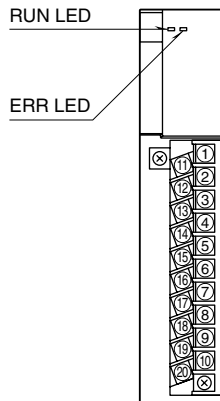

SIDE VIEW

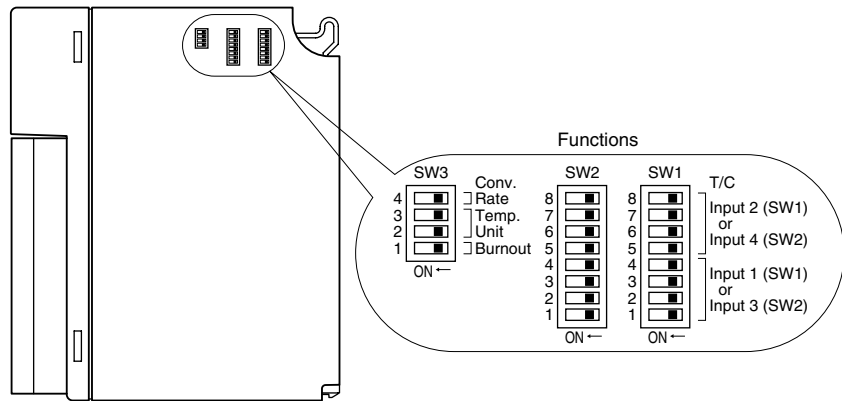

STATUS INDICATOR LED

- RUN indicator:** Bi-color (red/green) LED;
 Red when the bus A operates normally;
 Green when the bus B operates normally;
 Amber when both buses operate normally.
- ERR indicator:** Bi-color (red/green) LED;
 Red with burnout;
 Green in normal operating conditions.

SIDE DIP SW

(*) Factory setting

Thermocouple Type: SW1, SW2

INPUT 1 (SW1)				INPUT 2 (SW1)				T/C
INPUT 3 (SW2)				INPUT 4 (SW2)				
1	2	3	4	5	6	7	8	
OFF	OFF	OFF	OFF	OFF	OFF	OFF	OFF	K (CA) (*)
ON	OFF	OFF	OFF	ON	OFF	OFF	OFF	E (CRC)
OFF	ON	OFF	OFF	OFF	ON	OFF	OFF	J (IC)
ON	ON	OFF	OFF	ON	ON	OFF	OFF	T (CC)
OFF	OFF	ON	OFF	OFF	OFF	ON	OFF	B (RH)
ON	OFF	ON	OFF	ON	OFF	ON	OFF	R
OFF	ON	ON	OFF	OFF	ON	ON	OFF	S
ON	ON	ON	OFF	ON	ON	ON	OFF	C (WRe 5-26)
OFF	OFF	OFF	ON	OFF	OFF	OFF	ON	N
ON	OFF	OFF	ON	ON	OFF	OFF	ON	U
OFF	ON	OFF	ON	OFF	ON	OFF	ON	L
ON	ON	OFF	ON	ON	ON	OFF	ON	P (Platinel II)
OFF	OFF	ON	ON	OFF	OFF	ON	ON	(PR)

Burnout: SW3-1

SW3-1	BURNOUT
OFF	Upscale (*)
ON	Downscale

Temperature Unit: SW3-2, 3-3

SW3-2	SW3-3	TEMP. UNIT
OFF	OFF	°C (*)
ON	OFF	°F
OFF	ON	(Absolute Temp)

Conversion Rate: SW3-4

SW3-4	CONV. RATE
OFF	250 msec. (*)
ON	1 sec.

TERMINAL CONNECTIONS

Connect the unit as in the diagram below.

EXTERNAL DIMENSIONS unit: mm (inch)

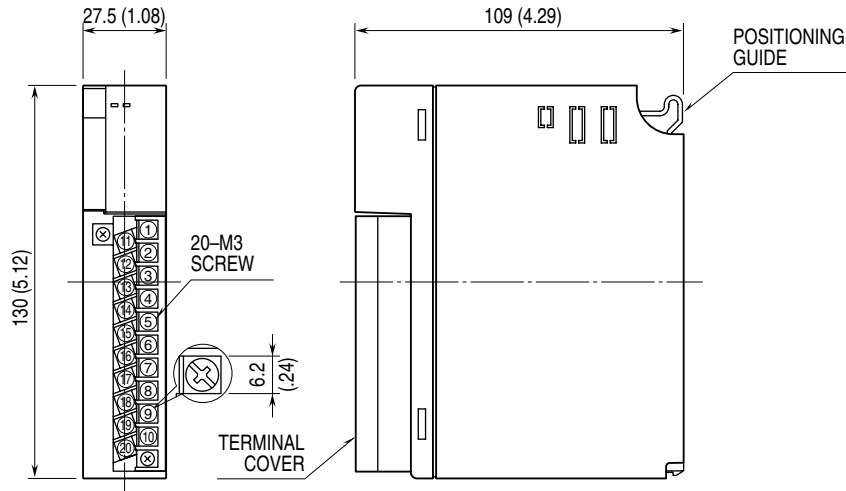

CONNECTION DIAGRAM

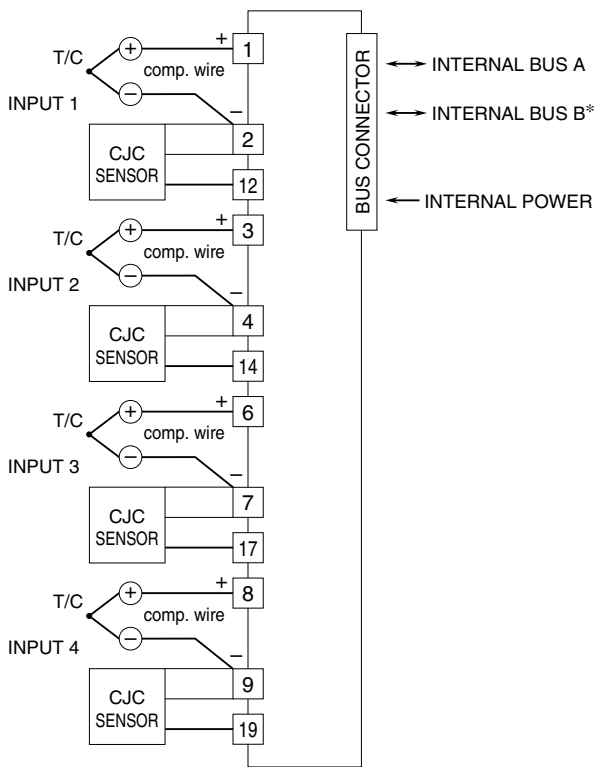

*For dual redundant communication.

Unused Input Channels

Close across the unused input terminals as shown below. (Choose K (CA) thermocouple for unused channels.)

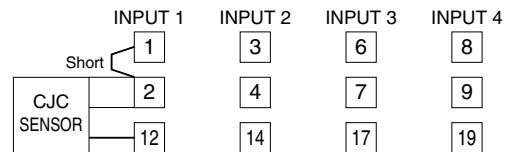

Unused channels left open are equal to the burnout, which turns the red ERR LED on and sets a burnout flag at the PLC or the host device.

Shortcircuiting the terminals means approximate room temperature. An alarm setpoint must be set to a value that does not trip an unwanted alarm.

Unused channels can be specified and set so on the PC Configurator Software (model: R3CON) without needing to short at the field terminals.

ALARM SETTING

The following parameters are programmable using the PC Configurator Software (model: R3CON).

■ ALARM TRIP POINT

(-270.0 to +2400.0°C or -454 to +4352°F; factory set to A1: 400.0°C, A2: 300.0°C, A3: 200.0°C, A4: 100.0°C)

Four alarm setpoints are selectable per each input.

■ ALARM TYPE (High or Low; factory set to A1: High, A2: High, A3: Low, A4: Low)

High or Low alarm is selectable for each alarm trip point.

High alarm: An alarm is set when the input signal goes above the setpoint.

Low alarm: An alarm is set when the input signal goes below the setpoint.

■ DEADBAND (HYSTERESIS)

(0.00 to 900.0°C or 0 to 1620°F; factory set to 10.0°C or 100°F)

Deadband (deviation between the points where the alarm is set and reset) is selectable for each alarm trip point.

■ POWER ON DELAY TIME

(0.0 to 99.0 seconds; factory set to 5.0)

The alarm output start functioning in the preset time after the power has been turned on.

This setting is common to all four points.

■ ALARM ON DELAY TIME

(0.0 to 99.0 seconds; factory set to 1.0)

The alarm output is set when the preset time elapses after the input has entered in the alarm range.

This setting is common to all four points.

■ ALARM HOLD TIME

(0.0 to 99.0 seconds; factory set to 1.0)

The alarm output is held for the preset time even if it is reset in shorter time.

This setting is common to all four points.

WIRING INSTRUCTIONS

■ SCREW TERMINAL

Torque: 0.5 N·m

■ SOLDERLESS TERMINAL

Refer to the drawing below for recommended ring tongue terminal size. Spade tongue type is also applicable. Solderless terminals with insulation sleeve do not fit.

Applicable wire size: 0.3 – 0.75 mm²

Recommended manufacturer: Japan Solderless Terminal MFG. Co., Ltd., Nichifu Co., Ltd.

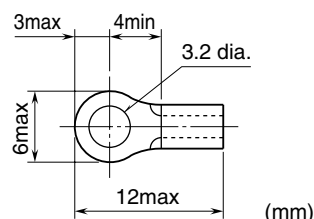

OUTPUT DATA DESCRIPTIONS

Four alarm setpoints are selectable per each input. One (1) word (16 bit) data is transmitted to the PLC or the host device via the R3 network module.

