

THERMOCOUPLE INPUT MODULE
(2 points, isolated)

MODEL **R8-TS2**

BEFORE USE

Thank you for choosing us. Before use, please check contents of the package you received as outlined below. If you have any problems or questions with the product, please contact our sales office or representatives.

PACKAGE INCLUDES:

- Thermocouple input module.....(1)
- CJC sensor.....(2)

MODEL NO.

Confirm Model No. marking on the product to be exactly what you ordered.

INSTRUCTION MANUAL

This manual describes necessary points of caution when you use this product, including installation, connection and basic maintenance procedures.

POINTS OF CAUTION

CONFORMITY WITH EU DIRECTIVES

- The equipment must be mounted inside a panel.
- The actual installation environments such as panel configurations, connected devices, connected wires, may affect the protection level of this unit when it is integrated in a panel system. The user may have to review the CE requirements in regard to the whole system and employ additional protective measures* to ensure the CE conformity.

* For example, installation of noise filters and clamp filters for the power source, input and output connected to the unit, etc.

GENERAL PRECAUTIONS

- Before you remove or mount the unit, turn off the power supply and input signal for safety.
- Switches on the side of the module can be set for maintenance only while the power supply is off. Do not access them while the power is supplied.

ENVIRONMENT

- Indoor use.
- When heavy dust or metal particles are present in the air, install the unit inside proper housing with sufficient ventilation. Do not subject the unit to physical impact.
- Do not install the unit where it is subjected to continuous vibration. Do not subject the unit to physical impact.
- Environmental temperature must be within -10 to +55°C (14 to 131°F) with relative humidity within 30 to 90% RH in order to ensure adequate life span and operation.

WIRING

- Do not install cables close to noise sources (relay drive cable, high frequency line, etc.).
- Do not bind these cables together with those in which noises are present. Do not install them in the same duct.

AND

- The unit is designed to function as soon as power is supplied, however, a warm up for 10 minutes is required for satisfying complete performance described in the data sheet.

INSTALLATION

HOW TO MOUNT THE MODULE ON DIN RAIL

I/O Module

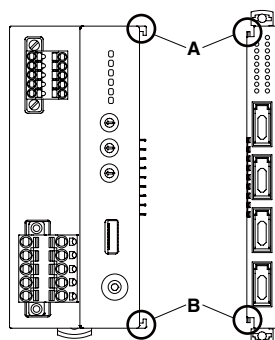

Confirm that the locking clamps of the I/O module are set. Insert the module in parallel to the next one while aligning the grooves of both modules (A & B in the above figure). Maintain it perpendicularly to the rail.

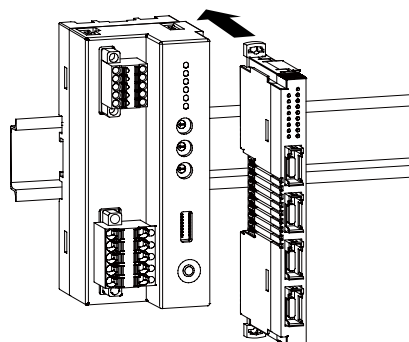

More I/O modules can be added in the same manner.

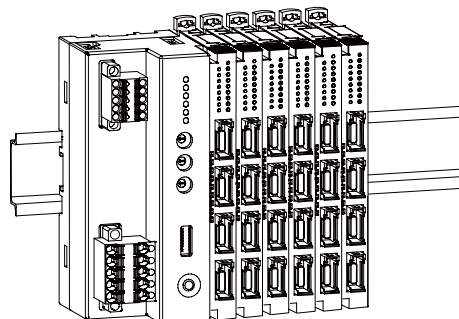

• Protective Cover

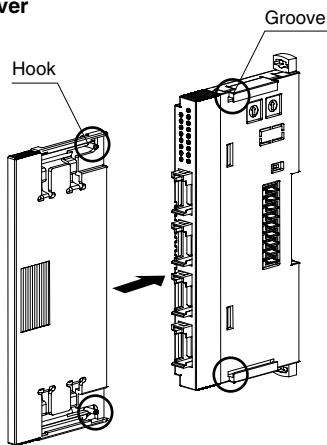

The protective cover is to be attached over the connected I/O module at the right end.
Align the hooks on the cover with the grooves of the module and slide it straight until the hooks are latched.

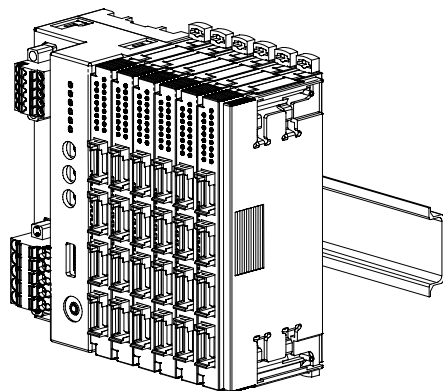

When removing the cover, pull it out while squeezing the hooks inward.

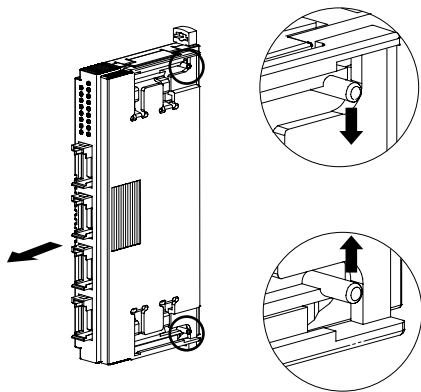

■ HOW TO UNMOUNT THE MODULE ON DIN RAIL

Release the locking clamps and pull out straight the module.

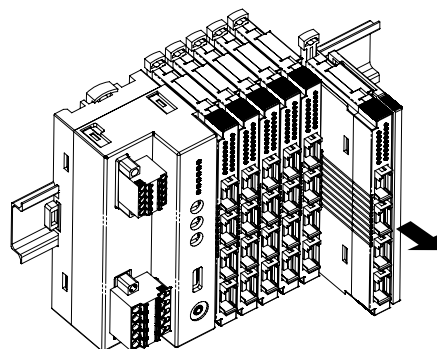
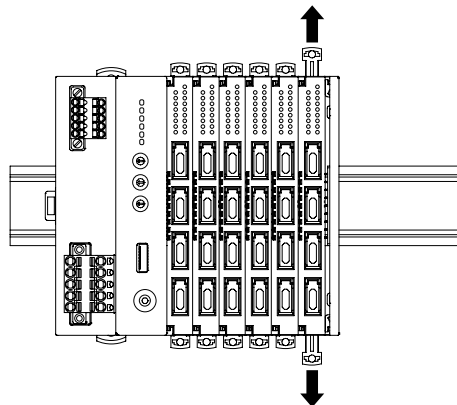

• Removing an intermediate module

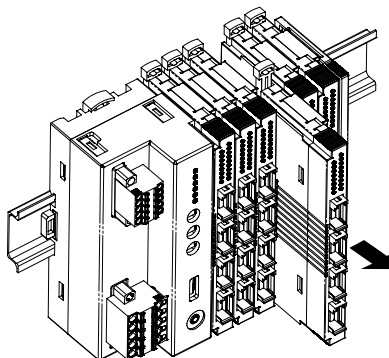
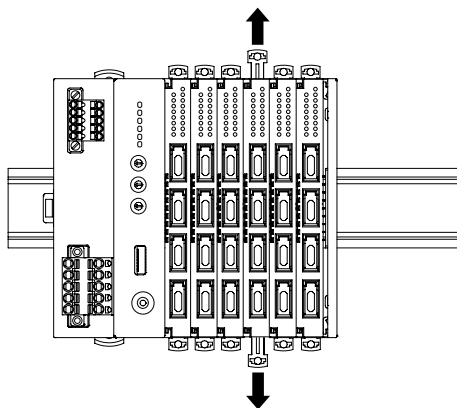

Caution !

- 1) Be careful not to hurt your hand by pointed edges of the internal bus connector.
- 2) I/O modules cannot hold tightly on the DIN rail by themselves without power/network module.
Secure them to the position if necessary by using DIN rail end plates.

COMPONENT IDENTIFICATION

FRONT VIEW

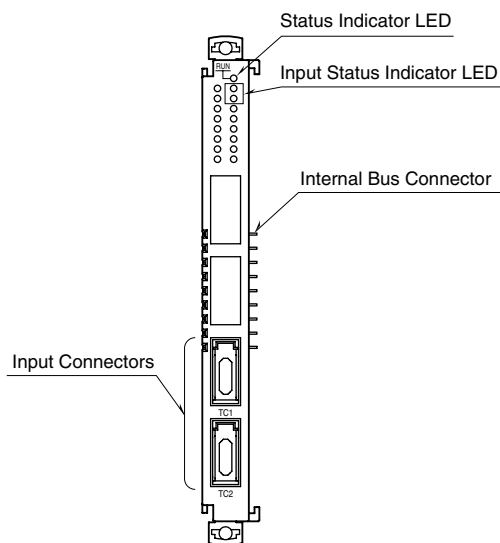

SIDE VIEW

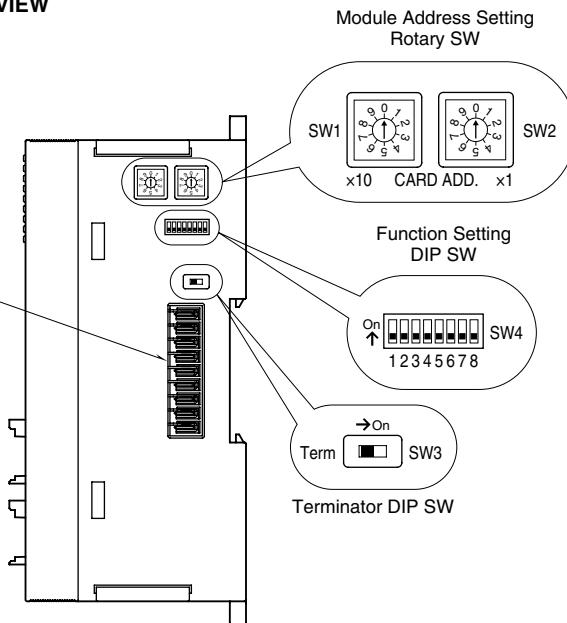

INDICATOR LED

ID	OPERATION	FUNCTION
Status	OFF	Stopping
	Green ON	Valid host communication
	Green Blinking	Reading/writing configuration
	Red ON	Setting error
	Red Blinking	Parameter error
Input Status	OFF	Input data in the range
	Red Blinking	Input data out of range
	Red ON	Burnout

INPUT CONNECTOR ASSIGNMENT

PIN No.	ID	FUNCTION
1	+	T/C (+)
2	-	T/C (-)
3	CJM	Cold junction compensation
4	CJM	Cold junction compensation

* No polarity for the CJC sensor.

MODULE ADDRESS: SW1, 2

The left switch determines the tenth place digit, while the right one does the ones place digit of the module address.

Address is selected between 0 to 31.

(Factory setting: 0)

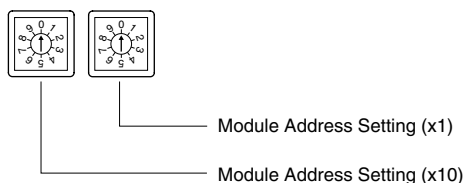

OPERATING MODE

(* Factory setting)

Thermocouple Type: SW4-1, 4-2, 4-3

Same setting for all channels. Use PC Configurator to set independent ranges per channel.

T/C TYPE	SW4		
	1	2	3
K (CA) (*)	OFF	OFF	OFF
E (CRC)	ON	OFF	OFF
J (IC)	OFF	ON	OFF
T (CC)	ON	ON	OFF
B (RH)	OFF	OFF	ON
R	ON	OFF	ON
S	OFF	ON	ON
C (WRe 5-26)	ON	ON	ON

Use PC Configurator Software (model: R8CFG) to set N, U, L, P (Platinel II) and PR thermocouples.

Burnout: SW4-7

BURNOUT	SW4-7
Upscale (*)	OFF
Downscale	ON

Configuration Mode: SW4-8

CONFIGURATION MODE	SW4-8
DIP switch setting (*)	OFF
PC Configurator and communication	ON

Note: Be sure to set unused SW4-4 through 4-6 to OFF.

TERMINATOR DIP SW: SW3

TERMINATOR SW	SW3
Without (*)	OFF
With	ON

PC CONFIGURATOR

The following parameter items can be configured with PC Configurator Software (model: R8CFG).
Refer to the users manual of the software for detailed operations.

■ CHANNEL INDIVIDUAL SETTING

PARAMETER	SETTING RANGE	DEFAULT SETTING
TC Type	K (CA) E (CRC) J (IC) T (CC) B (RH) R S C (WRe 5-26) N U L P (Platinel II) (PR) Not in use	K (CA)
Lower range value	Depends on sensor type	0.00 (degC)
Upper range value	Depends on sensor type	0.00 (degC)
Fine zero adjustment	-320.00 to +320.00 (%)	0.00 (%)
Fine gain adjustment	-3.2000 to +3.2000	1.0000
Scaled range Zero	-32000 to +32000	0
Scaled range Span	-32000 to +32000	10000

■ CHANNEL BATCH SETTING

PARAMETER	SETTING RANGE	DEFAULT SETTING
Burnout	Upscale, Downscale	Upscale
Temperature unit	degC, degF, K	degC
Cold junction compensation	ON, OFF	ON
Limit	-5 – +105%, Scaled range zero/span	-5 – +105%
Loss of internal bus communication detection time	0.0 to 99.9 (sec.)	1.0 (sec.)
Configuration mode	DIP switch (OFF), PC (ON)	DIP switch (OFF)

Note: Turn SW4-8 ON to allow programming by the PC Configurator via the Power/Network Module.

TERMINAL CONNECTIONS

Connect the unit as in the diagram below.

EXTERNAL DIMENSIONS unit: mm (inch)

BODY

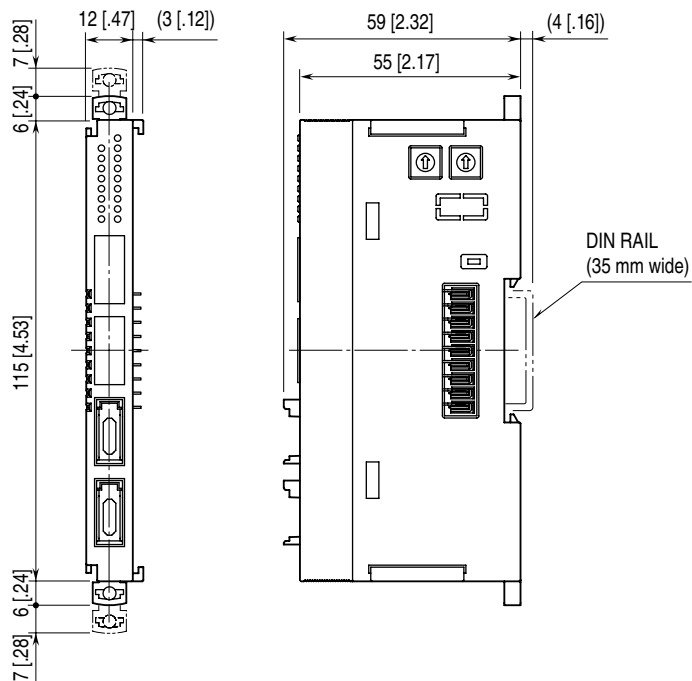

CJC SENSOR (CJM 2 pieces)

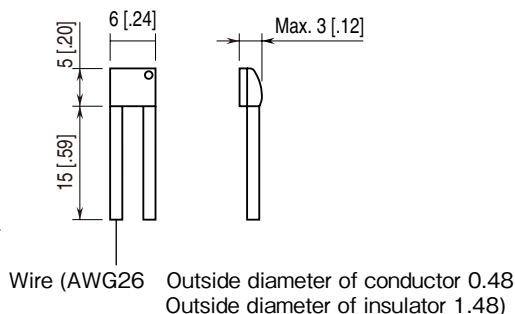

CONNECTION DIAGRAM

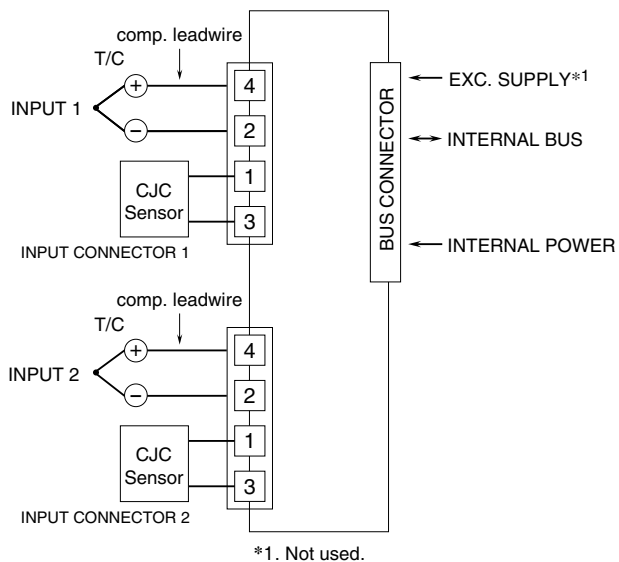

WIRING INSTRUCTIONS

e-CON connector

Unit side connector: XN2D-1474-S002 (Omron)
 Recommended cable side connector: XN2A-1470 (Omron)*1
 Applicable wire size: 0.08 to 0.5 mm² (AWG28 to 20)
 Outer sheath diameter: max. 1.5 dia
 *1. The cable side connector is not included in the package.
 Refer to the specifications of the product.