

## Remote I/O R7F4D Series

### CC-Link I/O MODULE

(PNP discrete input & PNP transistor output, 8 points each, tension clamp terminal block)

#### Functions & Features

- Interchanges discrete I/O signals with the fieldbus (CC-Link)

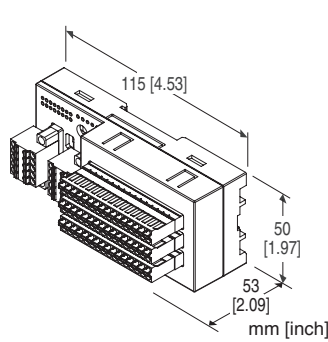

### MODEL: R7F4DC-DAC16D-C-R[1]

#### ORDERING INFORMATION

- Code number: R7F4DC-DAC16D-C-R[1]  
Specify a code from below for [1].  
(e.g. R7F4DC-DAC16D-C-R/Q)
- Specify the specification for option code /Q  
(e.g. /C01)

#### I/O TYPE

**DAC16D:** PNP discrete input & PNP transistor output, 8 points each

#### TERMINAL BLOCK

- C:** Tension clamp terminal block for power  
Tension clamp terminal block for communication  
Tension clamp terminal block for I/O

#### POWER INPUT

##### DC Power

R: 24 V DC

(Operational voltage range 24 V  $\pm$ 10 %, ripple 10 %p-p max.)

#### [1] OPTIONS

**blank:** none

**/Q:** With options (specify the specification)

#### SPECIFICATIONS OF OPTION: Q

**COATING (For the detail, refer to M-System's web site.)**

/C01: Silicone coating

/C02: Polyurethane coating

/C03: Rubber coating

#### RELATED PRODUCTS

- CSP+ file

The CSP+ file are downloadable at M-System's web site.

CSP+ file is also downloadable at CC-Link Partner Association's web site.

#### GENERAL SPECIFICATIONS

##### Connection

**CC-Link:** Tension clamp terminal block

**Power supply, exc. supply:** Tension clamp terminal block

**I/O:** Tension clamp terminal block

**Housing material:** Flame-resistant resin (gray)

**Isolation:** Input or output or exc. supply to CC-Link to power supply to FE1

**Discrete I/O status indicator LED:** Green LED turns on with I/O ON

#### CC-Link COMMUNICATION

**Transmission:** CC-Link ver.1.10

**Network cable:** CC-Link cable designated by Mitsubishi Electric

**Station type:** Remote I/O device

**Station number:** 1 - 64 (rotary switch, default:00)

**Baud rate setting:** 156 kbps (default), 625 kbps, 2.5 Mbps, 5 Mbps, 10 Mbps (DIP switch)

**Terminating resistor:** Built-in (DIP Switch, default: disable)

**Status indicator LEDs:** Power, Run, Error, SD, RD

For details, refer to the users manual.

#### INPUT SPECIFICATIONS

**Common:** Negative common (PNP) per 8 points

**Number of inputs:** 8

**Maximum inputs applicable at once:** No limit (at 24 V DC)

**Sensor excitation:** 24 V DC  $\pm$ 10 %; ripple 5 %p-p max.,  $\leq$  1 A (including discrete input load charge); rated current 8 A

**ON voltage / current:**  $\geq$  17 V DC (X0 through X7 to +24V) /  $\geq$  2.3 mA

**OFF voltage / current:**  $\leq$  5 V DC (X0 through X7 to +24V) /  $\leq$  0.75 mA

**Input current:**  $\leq$  3.5 mA per point at 24 V DC

**Input resistance:** Approx. 7.2 k $\Omega$

**ON delay:**  $\leq$  0.5 msec.

**OFF delay:**  $\leq$  0.5 msec.

## OUTPUT SPECIFICATIONS

**Common:** Positive common (PNP) per 8 points

**Number of output:** 8 points

**Maximum outputs applicable at once:** No limit (at 24 V DC)

**Rated load voltage:** 24 V DC  $\pm 10\%$ ; ripple 5 %p-p max.,  
 $\leq 1$  A (including discrete output load charge); rated current  
8 A

**Rated output current:** 0.1 A per point, 0.8 A per common

**Residual voltage:**  $\leq 1.2$  V

**Leakage current:**  $\leq 0.1$  mA

**ON delay:**  $\leq 0.2$  msec.

**OFF delay:**  $\leq 0.5$  msec.

With shortcircuit protection

With overheat protection

(When driving an inductive load, connect a diode in parallel  
with the load.)

## INSTALLATION

### Current consumption

•DC: Approx. 30 mA

(contact I/O load charge is not included)

**Operating temperature:** -10 to +55°C (14 to 131°F)

**Storage temperature:** -20 to +65°C (-4 to +149°F)

**Operating humidity:** 30 to 90 %RH (non-condensing)

**Atmosphere:** No corrosive gas or heavy dust

**Mounting:** Surface or DIN rail (35 mm rail)

**Weight:** 150 g (0.33 lb)

## PERFORMANCE

**Insulation resistance:**  $\geq 100$  M $\Omega$  with 500 V DC

**Dielectric strength:** 1500 V AC @ 1 minute

(input or output or exc. supply to CC-Link to power supply to  
FE1)

## STANDARDS & APPROVALS

**EU conformity:**

EMC Directive

EMI EN 61000-6-4

EMS EN 61000-6-2

RoHS Directive

## EXTERNAL VIEW

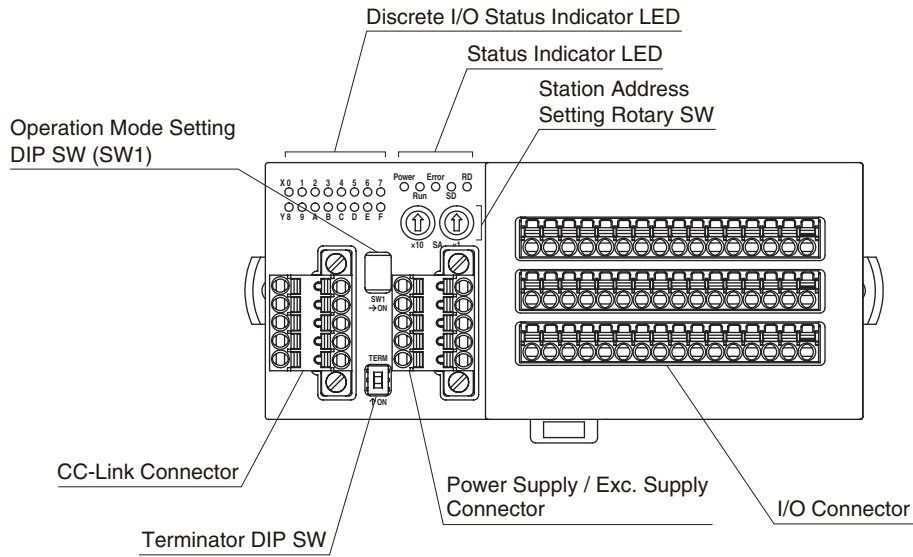

## COMMUNICATION CABLE WIRING

### ■ MASTER CONNECTION

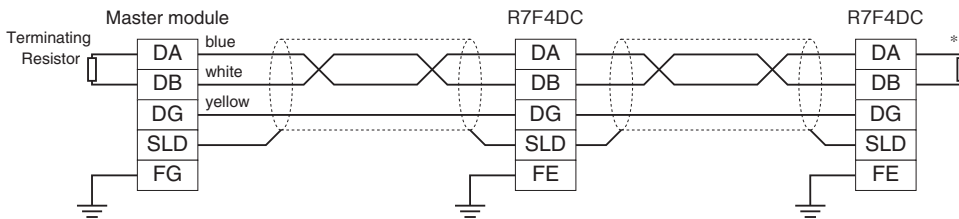

\*1. Turn on the terminator DIP switch to activate the internal terminating resistor.

## TERMINAL ASSIGNMENTS

### ■ CC-Link, POWER SUPPLY, EXC. SUPPLY ASSIGNMENT

Unit side connector: MCV1,5/5-GF-3,5 (Phoenix contact)

Cable side connector: TFMC1,5/5-STF-3,5 (Phoenix contact)

Applicable wire size: 0.2 - 1.5mm<sup>2</sup>

Stripped length: 10mm

Recommended solderless terminal:

AI0,25-10YE 0.25mm<sup>2</sup> (Phoenix contact)

AI0,34-10TQ 0.34mm<sup>2</sup> (Phoenix contact)

AI0,5-10WH 0.5mm<sup>2</sup> (Phoenix contact)

AI0,75-10GY 0.75mm<sup>2</sup> (Phoenix contact)

AI1-10 1.0mm<sup>2</sup> (Phoenix contact)

AI1,5-10 1.5mm<sup>2</sup> (Phoenix contact)

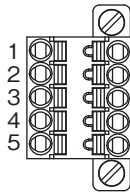

#### · CC-Link

PIN NO.	ID	FUNCTION
1	FE	Function earth
2	SLD	Shield
3	DB	DB
4	DG	DG
5	DA	DA

Note: The numbers marked on the connector have no relationship to the pin number of the unit. Wire according to the instruction manual of the unit.

#### · POWER SUPPLY / EXC. SUPPLY

PIN NO.	ID	FUNCTION
1	PWR+	Power supply +
2	PWR-	Power supply -
3	FE1	Grounding
4	SNSR.EXC+	Exc. supply +
5	SNSR.EXC-	Exc. supply -

### ■ I/O TERMINAL ASSIGNMENT

# MODEL: R7F4DC-DAC16D-C

Unit side connector: MCV1,5/16-G-3,5 (Phoenix Contact)  
 Cable side connector: FMC1,5/16-ST-3,5 (Phoenix Contact)  
 Applicable wire size: 0.2 - 1.5mm<sup>2</sup>  
 Stripped length: 10mm  
 Recommended solderless terminal  
 AI0,25-10YE 0.25mm<sup>2</sup> (Phoenix Contact)  
 AI0,34-10TQ 0.34mm<sup>2</sup> (Phoenix Contact)  
 AI0,5-10WH 0.5mm<sup>2</sup> (Phoenix Contact)  
 AI0,75-10GY 0.75mm<sup>2</sup> (Phoenix Contact)  
 AI1-10 1.0mm<sup>2</sup> (Phoenix Contact)  
 AI1,5-10 1.5mm<sup>2</sup> (Phoenix Contact)

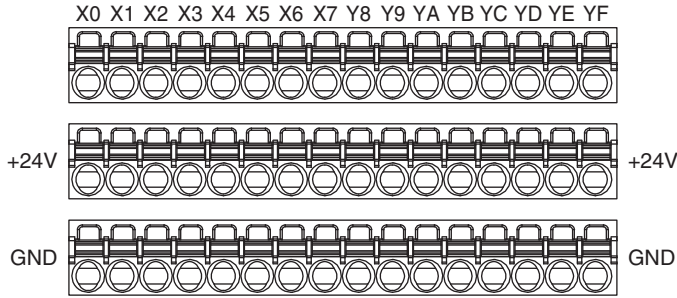

PIN NO.	ID	FUNCTION	PIN NO.	ID	FUNCTION
X0	1	X0	Y8	1	Y8
	2	+24V		2	+24V
	3	GND		3	GND
X1	1	X1	Y9	1	Y9
	2	+24V		2	+24V
	3	GND		3	GND
X2	1	X2	YA	1	YA
	2	+24V		2	+24V
	3	GND		3	GND
X3	1	X3	YB	1	YB
	2	+24V		2	+24V
	3	GND		3	GND
X4	1	X4	YC	1	YC
	2	+24V		2	+24V
	3	GND		3	GND
X5	1	X5	YD	1	YD
	2	+24V		2	+24V
	3	GND		3	GND
X6	1	X6	YE	1	YE
	2	+24V		2	+24V
	3	GND		3	GND
X7	1	X7	YF	1	YF
	2	+24V		2	+24V
	3	GND		3	GND

## DATA ALLOCATION

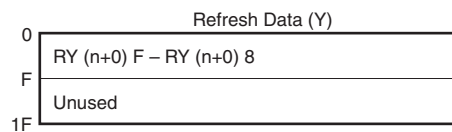
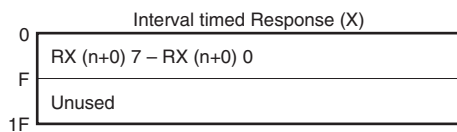

## I/O DATA DESCRIPTIONS

### ■ DISCRETE I/O

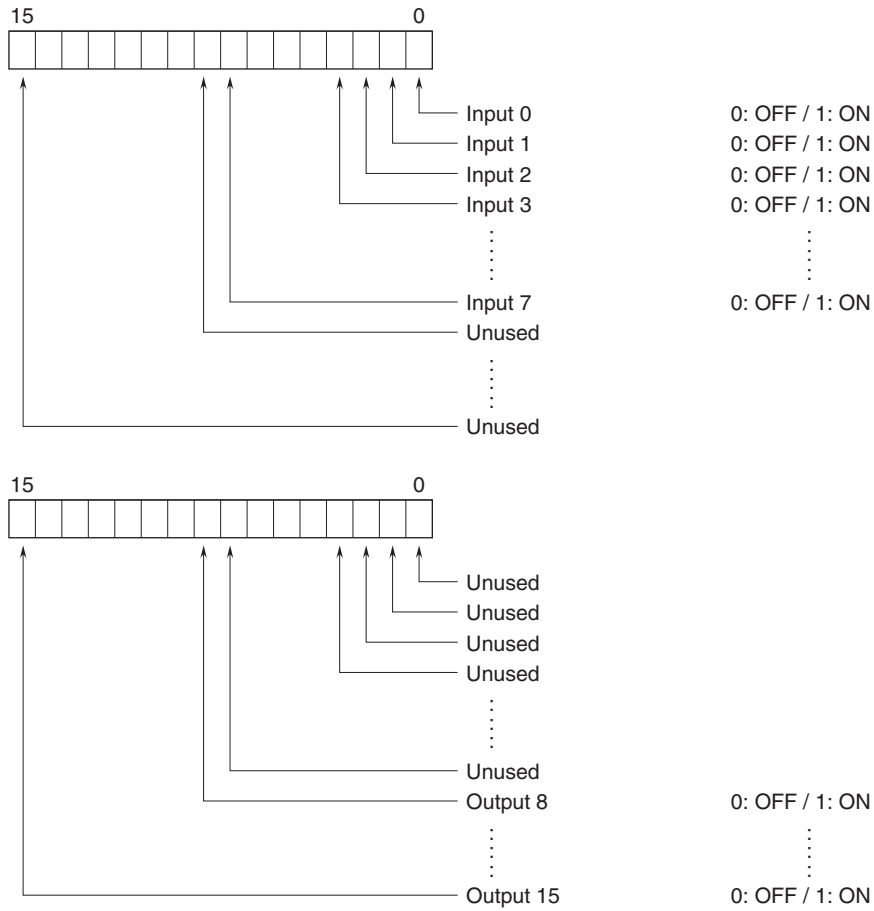

## EXTERNAL DIMENSIONS unit: mm [inch]

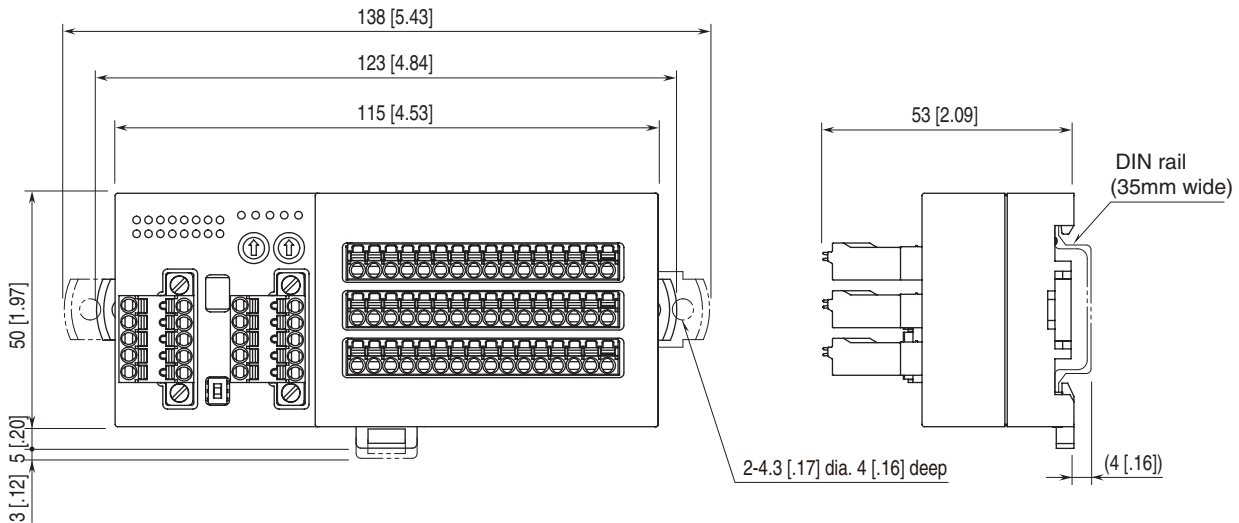

# MODEL: R7F4DC-DAC16D-C

## MOUNTING REQUIREMENTS unit: mm [inch]

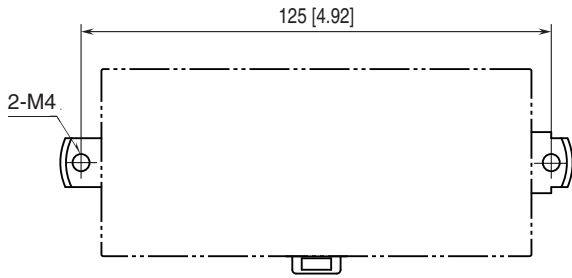

## SCHEMATIC CIRCUITRY & CONNECTION DIAGRAM

Note: In order to improve EMC performance, bond the FE1 terminal to ground.  
 Caution: FE1 terminal is NOT a protective conductor terminal.

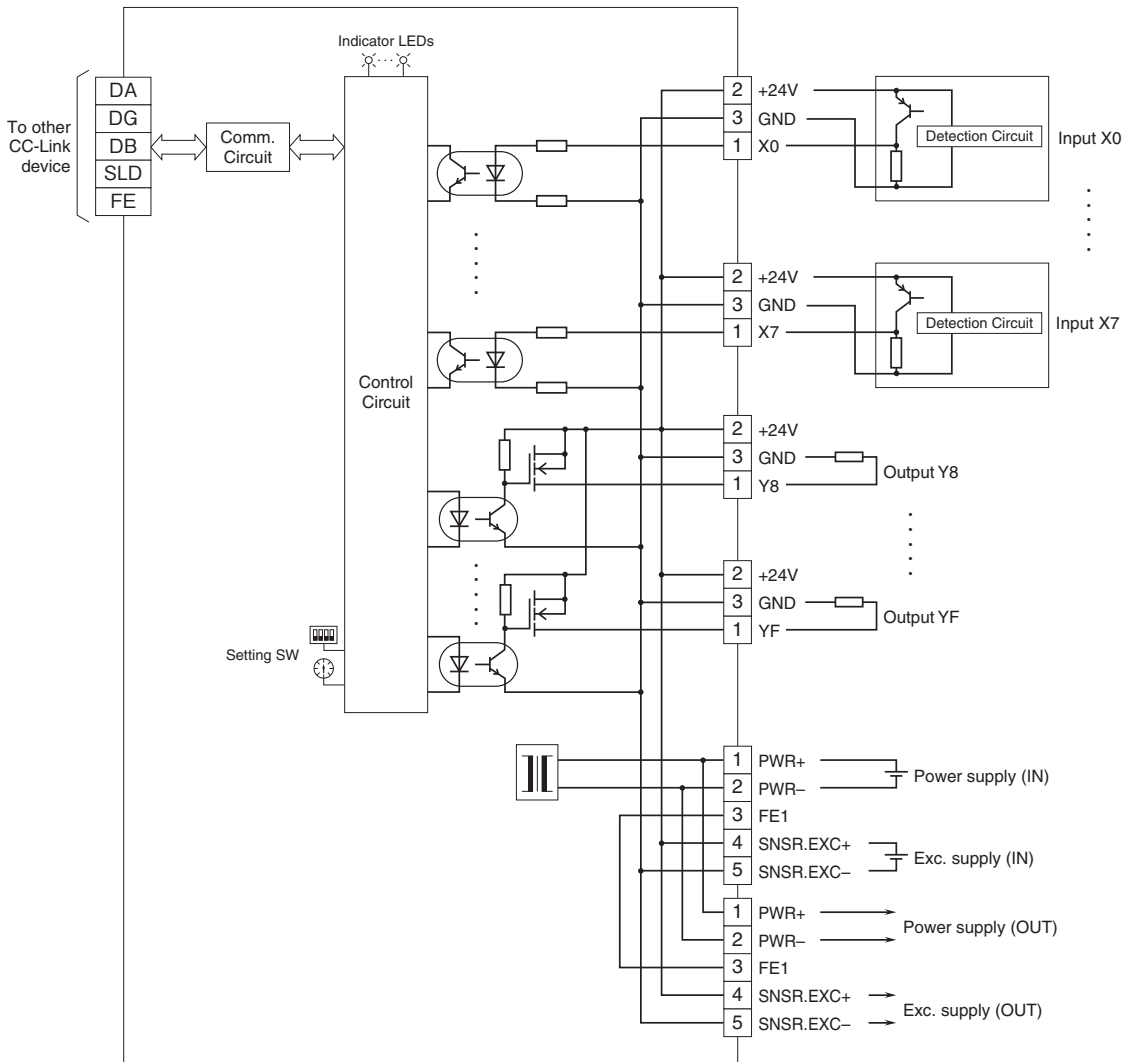

### ■ 2-WIRE SENSOR

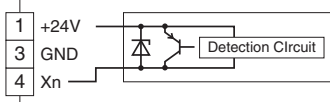



Specifications are subject to change without notice.