

Remote I/O R7F4D Series

CC-Link I/O MODULE

(NPN discrete input & NPN transistor output, 8 points each, one-touch connector)

Functions & Features

- Interchanges discrete I/O signals with the fieldbus (CC-Link)

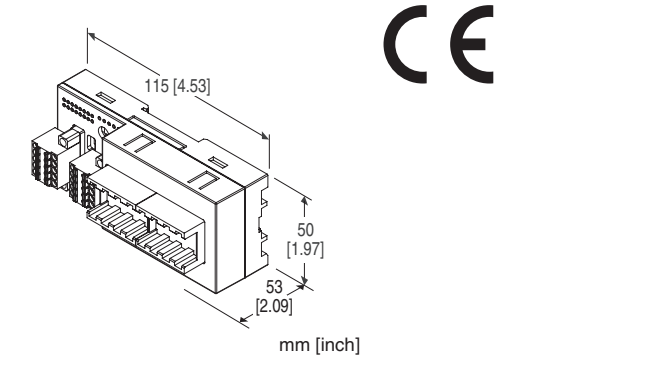

MODEL: R7F4DC-DAC16C-J-R[1]

ORDERING INFORMATION

- Code number: R7F4DC-DAC16C-J-R[1]
Specify a code from below for [1].
(e.g. R7F4DC-DAC16C-J-R/Q)
- Specify the specification for option code /Q
(e.g. /C01)

I/O TYPE

DAC16C: NPN discrete input & NPN transistor output, 8 points each

TERMINAL BLOCK

- J: Tension clamp terminal block for power
Tension clamp terminal block for communication
One-touch connector for I/O

POWER INPUT

DC Power

R: 24 V DC

(Operational voltage range 24 V \pm 10 %, ripple 10 %p-p max.)

[1] OPTIONS

blank: none

/Q: With options (specify the specification)

SPECIFICATIONS OF OPTION: Q

COATING (For the detail, refer to M-System's web site.)

/C01: Silicone coating

/C02: Polyurethane coating

/C03: Rubber coating

RELATED PRODUCTS

- CSP+ file

The CSP+ file are downloadable at M-System's web site.

CSP+ file is also downloadable at CC-Link Partner Association's web site.

GENERAL SPECIFICATIONS

Connection

CC-Link: Tension clamp terminal block

Power supply, exc. supply: Tension clamp terminal block

I/O: One-touch connector

Housing material: Flame-resistant resin (gray)

Isolation: Input or output or exc. supply to CC-Link to power supply to FE1

Discrete I/O status indicator LED: Green LED turns on with I/O ON

CC-Link COMMUNICATION

Transmission: CC-Link ver.1.10

Network cable: CC-Link cable designated by Mitsubishi Electric

Station type: Remote I/O device

Station number: 1 - 64 (rotary switch, default:00)

Baud rate setting: 156 kbps (default), 625 kbps, 2.5 Mbps, 5 Mbps, 10 Mbps (DIP switch)

Terminating resistor: Built-in (DIP Switch, default: disable)

Status indicator LEDs: Power, Run, Error, SD, RD

For details, refer to the users manual.

INPUT SPECIFICATIONS

Common: Positive common (NPN) per 8 points

Number of inputs: 8

Maximum inputs applicable at once: No limit (at 24 V DC)

Sensor excitation: 24 V DC \pm 10 %; ripple 5 %p-p max., \leq 1 A (including discrete input load charge); rated current 8 A

ON voltage / current: \geq 17 V DC (X0 through X7 to +24V) / \geq 2.3 mA

OFF voltage / current: \leq 5 V DC (X0 through X7 to +24V) / \leq 0.75 mA

Input current: \leq 3.5 mA per point at 24 V DC

Input resistance: Approx. 7.2 k Ω

ON delay: \leq 0.5 msec.

OFF delay: \leq 0.5 msec.

OUTPUT SPECIFICATIONS

Common: Negative common (NPN) per 8 points

Number of output: 8 points

Maximum outputs applicable at once: No limit (at 24 V DC)

Rated load voltage: 24 V DC $\pm 10\%$; ripple 5 %p-p max.,
 ≤ 1 A (including discrete output load charge); rated current
8 A

Rated output current: 0.1 A per point, 0.8 A per common

Residual voltage: ≤ 1.2 V

Leakage current: ≤ 0.1 mA

ON delay: ≤ 0.2 msec.

OFF delay: ≤ 0.5 msec.

With shortcircuit protection

With overheat protection

(When driving an inductive load, connect a diode in parallel
with the load.)

INSTALLATION

Current consumption

•DC: Approx. 30 mA

(contact I/O load charge is not included)

Operating temperature: -10 to +55°C (14 to 131°F)

Storage temperature: -20 to +65°C (-4 to +149°F)

Operating humidity: 30 to 90 %RH (non-condensing)

Atmosphere: No corrosive gas or heavy dust

Mounting: Surface or DIN rail (35 mm rail)

Weight: 120 g (0.26 lb)

PERFORMANCE

Insulation resistance: ≥ 100 M Ω with 500 V DC

Dielectric strength: 1500 V AC @ 1 minute

(input or output or exc. supply to CC-Link to power supply to
FE1)

STANDARDS & APPROVALS

EU conformity:

EMC Directive

EMI EN 61000-6-4

EMS EN 61000-6-2

RoHS Directive

EXTERNAL VIEW

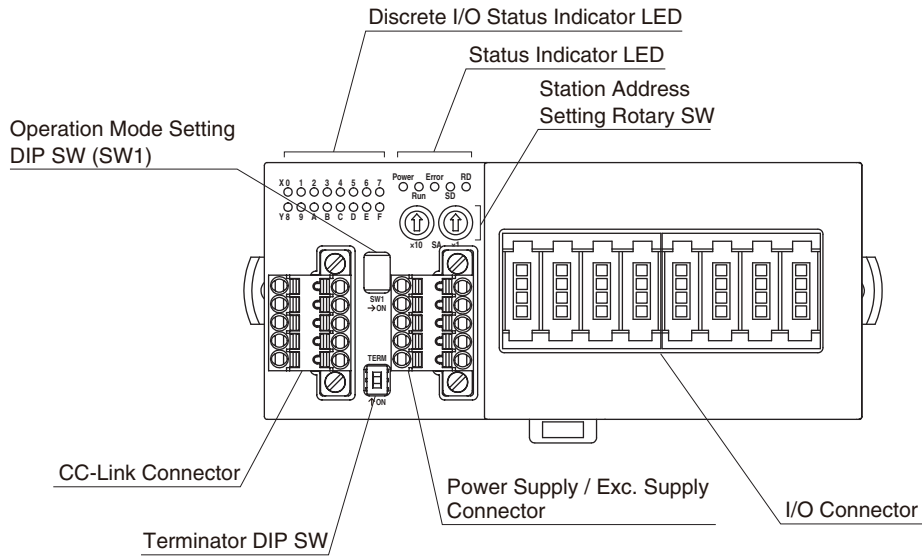

COMMUNICATION CABLE WIRING

■ MASTER CONNECTION

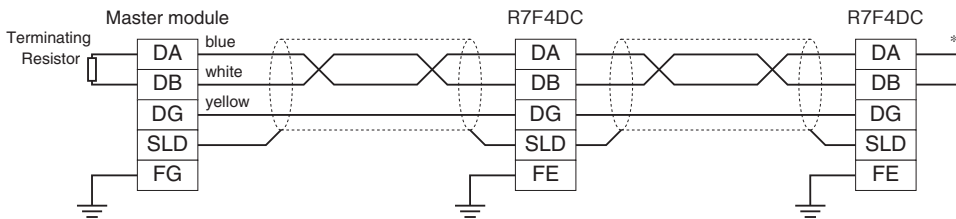

*1. Turn on the terminator DIP switch to activate the internal terminating resistor.

TERMINAL ASSIGNMENTS

■ CC-Link, POWER SUPPLY, EXC. SUPPLY ASSIGNMENT

Unit side connector: MCV1,5/5-GF-3,5 (Phoenix contact)
 Cable side connector: TFMC1,5/5-STF-3,5 (Phoenix contact)
 Applicable wire size: 0.2 - 1.5mm²
 Stripped length: 10mm
 Recommended solderless terminal:
 AI0,25-10YE 0.25mm² (Phoenix contact)
 AI0,34-10TQ 0.34mm² (Phoenix contact)
 AI0,5-10WH 0.5mm² (Phoenix contact)
 AI0,75-10GY 0.75mm² (Phoenix contact)
 AI1-10 1.0mm² (Phoenix contact)
 AI1,5-10 1.5mm² (Phoenix contact)

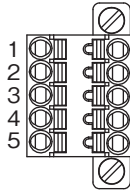

· CC-Link

PIN NO.	ID	FUNCTION
1	FE	Function earth
2	SLD	Shield
3	DB	DB
4	DG	DG
5	DA	DA

Note: The numbers marked on the connector have no relationship to the pin number of the unit. Wire according to the instruction manual of the unit.

· POWER SUPPLY / EXC. SUPPLY

PIN NO.	ID	FUNCTION
1	PWR+	Power supply +
2	PWR-	Power supply -
3	FE1	Grounding
4	SNSR.EXC+	Exc. supply +
5	SNSR.EXC-	Exc. supply -

■ I/O TERMINAL ASSIGNMENT

MODEL: R7F4DC-DAC16C-J

Unit side connector: 33216-62M3 PL (3M Company)

Cable side connector: 33104-6()00 FL (3M Company)

(The cable connector is not included in the package. Specify wire size instead of (); refer to the specifications of the product)

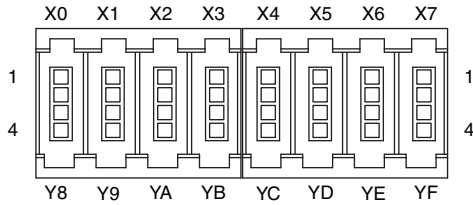

PIN NO.	ID	FUNCTION	PIN NO.	ID	FUNCTION		
X0	1	X0	Input 0	X4	1	X4	Input 4
Y8	2	Y8	Output 8	YC	2	YC	Output 12
	3	+24V	24V DC		3	+24V	24V DC
	4	GND	0V		4	GND	0V
X1	1	X1	Input 1	X5	1	X5	Input 5
Y9	2	Y9	Output 9	YD	2	YD	Output 13
	3	+24V	24V DC		3	+24V	24V DC
	4	GND	0V		4	GND	0V
X2	1	X2	Input 2	X6	1	X6	Input 6
YA	2	YA	Output 10	YE	2	YE	Output 14
	3	+24V	24V DC		3	+24V	24V DC
	4	GND	0V		4	GND	0V
X3	1	X3	Input 3	X7	1	X7	Input 7
YB	2	YB	Output 11	YF	2	YF	Output 15
	3	+24V	24V DC		3	+24V	24V DC
	4	GND	0V		4	GND	0V

DATA ALLOCATION

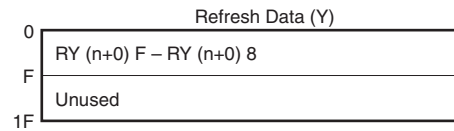
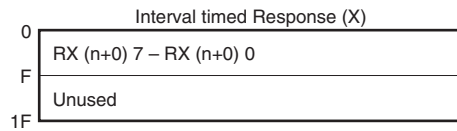

I/O DATA DESCRIPTIONS

■ DISCRETE I/O

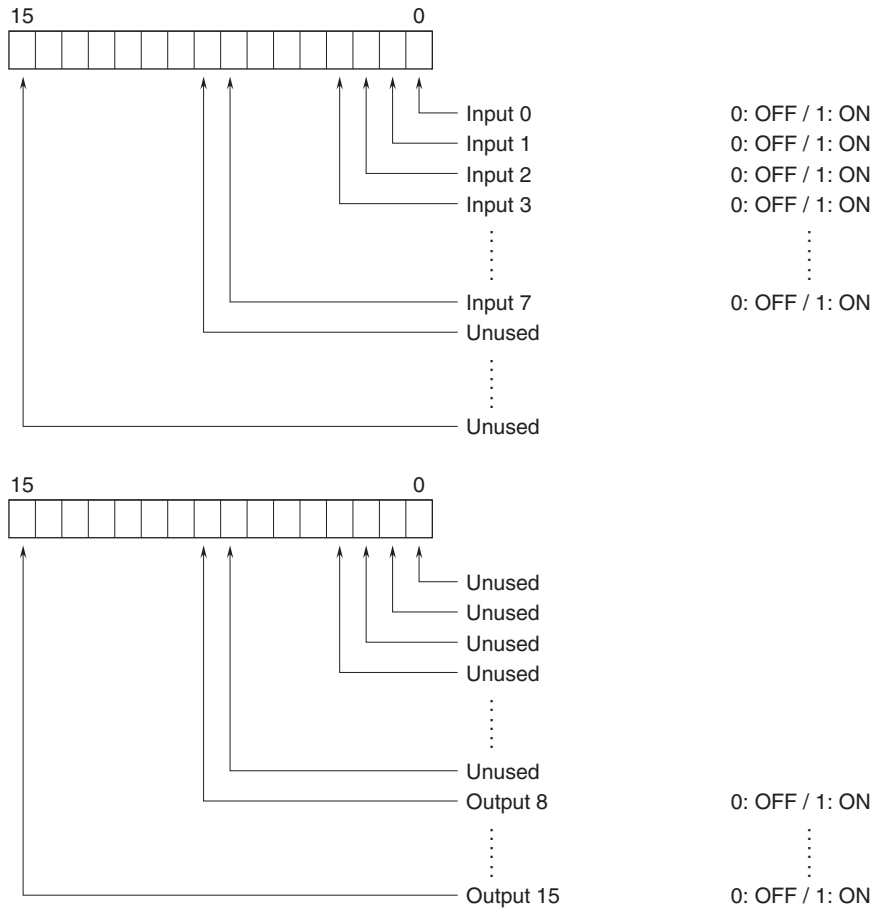

EXTERNAL DIMENSIONS unit: mm [inch]

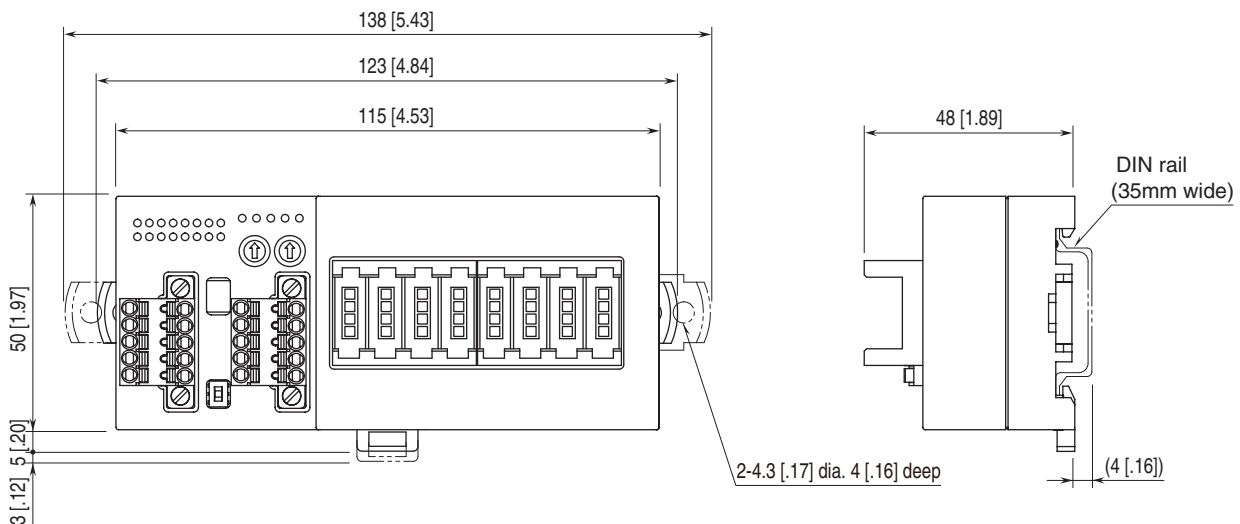

MOUNTING REQUIREMENTS unit: mm [inch]

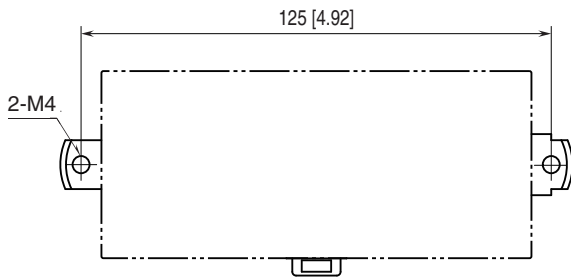

SCHEMATIC CIRCUITRY & CONNECTION DIAGRAM

Note: In order to improve EMC performance, bond the FE1 terminal to ground.

Caution: FE1 terminal is NOT a protective conductor terminal.

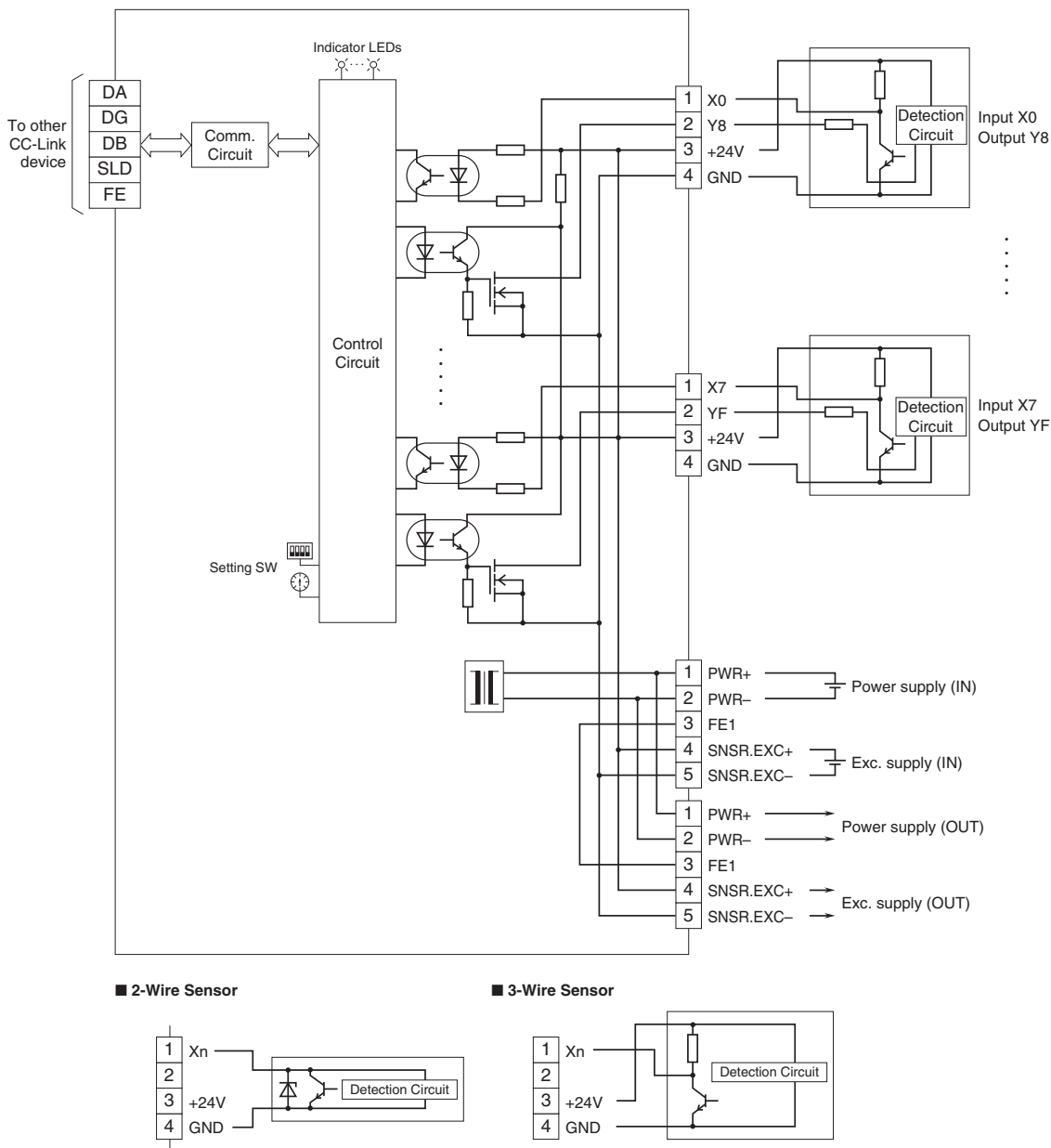



Specifications are subject to change without notice.