

POTENTIOMETER TRANSMITTER

(field- and PC-configurable)

MODEL **M3LM**

BEFORE USE

Thank you for choosing us. Before use, please check contents of the package you received as outlined below.

If you have any problems or questions with the product, please contact our sales office or representatives.

■ PACKAGE INCLUDES:

Signal conditioner(1)
I/O range and tag name label sheet(1)

■ MODEL NO.

Confirm Model No. marking on the product to be exactly what you ordered.

■ INSTRUCTION MANUAL

This manual describes necessary points of caution when you use this product, including installation, connection and basic maintenance procedures. For detailed information, refer to the operating manual (EM-2663-B).

The M3LM with Option A is programmable using the PC configurator software. For detailed information on the PC configuration, refer to the M3CFG instruction manual. The M3CFG PC Configurator Software and operating manual are downloadable at our web site.

POINTS OF CAUTION

■ CONFORMITY WITH UL

- This equipment is suitable for use in a Pollution Degree 2 environment.
- This equipment is to be used with the maximum operating voltage 30Vrms and 42.4Vpeak or 60V DC.
- The equipment must be mounted inside a suitable fire enclosure.
- Operating temperature: -25 to +55°C (-13 to +131°F)

■ CONFORMITY WITH EU DIRECTIVES

- The equipment must be mounted inside a panel.
- Insert noise filters for the power source, input and output connected to the unit. COSEL Model NAC-04-472, TDK Model ZCAT 3035-1330 or equivalent is recommended.
- The actual installation environments such as panel configurations, connected devices, connected wires, may affect the protection level of this unit when it is integrated in a panel system. The user may have to review the CE requirements in regard to the whole system and employ additional protective measures* to ensure the CE conformity.
 - * For example, installation of noise filters and clamp filters for the power source, input and output connected to the unit, etc.
- Install lightning surge protectors for those wires connected to remote locations.

■ POWER INPUT RATING & OPERATIONAL RANGE

- Locate the power input rating marked on the product and confirm its operational range as indicated below:
10 – 32V DC rating: 9 – 36V, approx. 3W

■ GENERAL PRECAUTION

- Before you remove the unit or mount it, turn off the power supply and input signal for safety.

■ ENVIRONMENT

- Indoor use.
- When heavy dust or metal particles are present in the air, install the unit inside proper housing with sufficient ventilation.
- Do not install the unit where it is subjected to continuous vibration. Do not subject the unit to physical impact.
- Environmental temperature must be within -25 to +65°C (-13 to +149°F) with relative humidity within 0 to 95% RH in order to ensure adequate life span and operation.
- Be sure that the ventilation slits are not covered with cables, etc.

■ WIRING

- Do not install cables close to noise sources (relay drive cable, high frequency line, etc.).
- Do not bind these cables together with those in which noises are present. Do not install them in the same duct.

■ AND

- The unit is designed to function as soon as power is supplied, however, a warm up for 10 minutes is required for satisfying complete performance described in the data sheet.

LIGHTNING SURGE PROTECTION

We offer a series of lightning surge protector for protection against induced lightning surges. Please contact us to choose appropriate models.

COMPONENT IDENTIFICATION

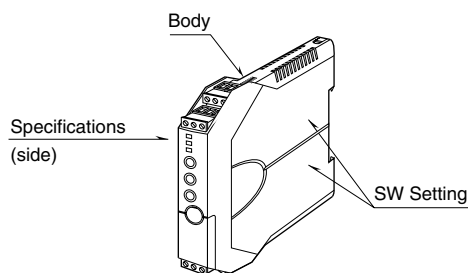

■ HOW TO OPEN THE COVER WHEN SETTING DIP SW

Hold at the top and bottom of the unit as shown below and slide the housing cover gently to open until it hits the latching inside the unit.

Caution:
Handle the cover carefully to protect internal components from damage.
DO NOT pull beyond where the housing cover is latched. The plastic housing may be damaged.

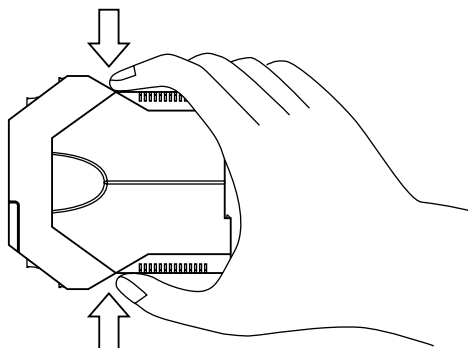

• Housing Cover Fully Opened

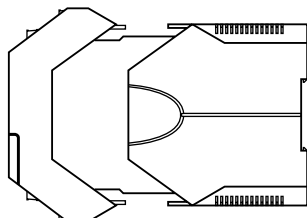

■ HOW TO SEPARATE THE EURO TYPE CONNECTOR TERMINAL BLOCKS

When you need to separate the euro type connector terminal blocks from the transmitter body for wiring, insert a minus driver between the euro type connector terminal block and the housing body, pull up the driver and pull out the euro type connector terminal block.

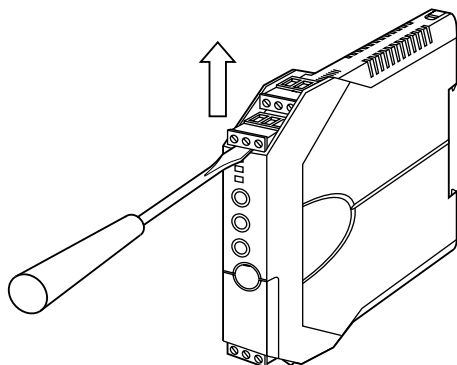

INSTALLATION

■ DIN RAIL MOUNTING

Set the unit so that its DIN rail adaptor is at the bottom. Position the upper hook at the rear side of the unit on the DIN rail and push in the lower. When removing the unit, push down the DIN rail adaptor utilizing a minus screwdriver and pull.

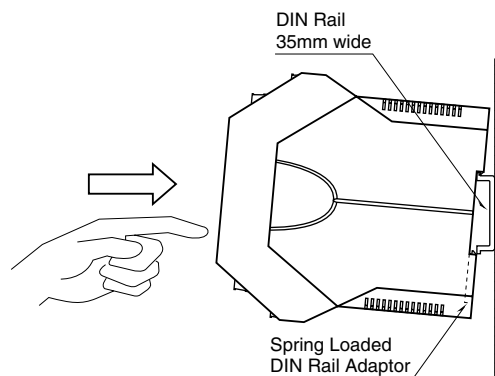

TERMINAL CONNECTIONS

Connect the unit as in the diagram below or refer to the connection diagram on the side of the unit.

EXTERNAL DIMENSIONS unit: mm (inch)

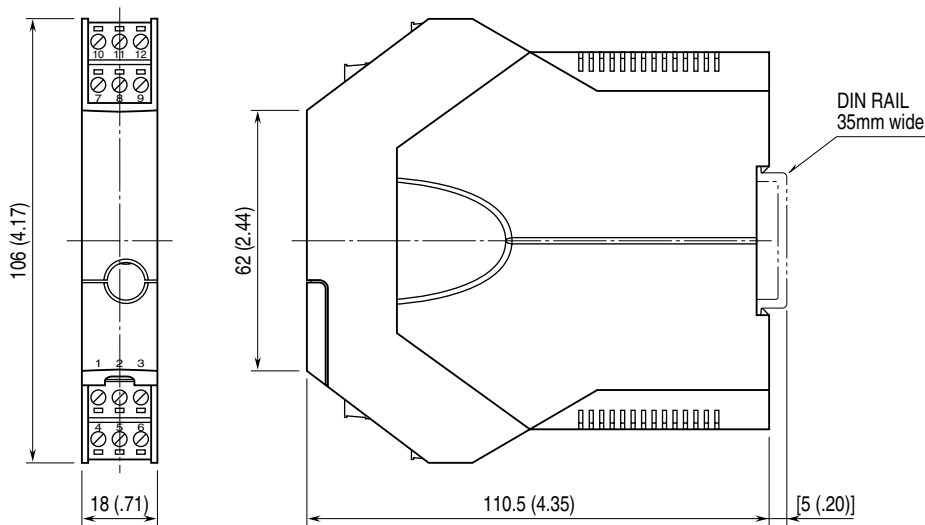

• When mounting, no extra space is needed between units.

CONNECTION DIAGRAM

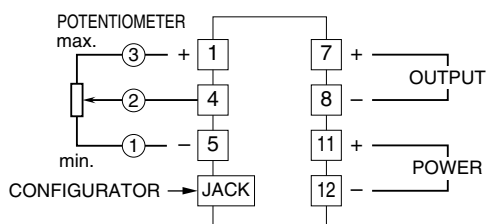

WIRING INSTRUCTIONS

Applicable wire size

Solid: 0.2 to 2.5 mm² (0.55 to 1.75 dia.)

Stranded: 0.2 to 2.5 mm²

Tinning wire ends may cause contact failure and therefore is not recommended.

Ferruled: 0.2 to 1.5 mm² (0.55 to 1.35 dia.)

The following Phoenix Contact terminals are recommended:

AI 0,25-8YE	0.2 to 0.25 mm ²
AI 0,34-8TQ	0.25 to 0.34 mm ²
AI 0,5-8WH	0.34 to 0.5 mm ²
AI 0,75-8GY	0.5 to 0.75 mm ²
AI 1,0-8RD	0.75 to 1.0 mm ²
AI 1,5-8BK	1.0 to 1.5 mm ²

Expose wire conductors by 8 mm (0.31").

Wire exposure

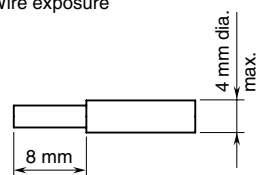

Recommended ferruled wire

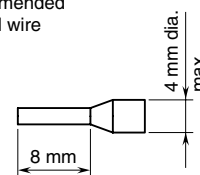

EXTERNAL & INTERNAL VIEWS

FRONT VIEW

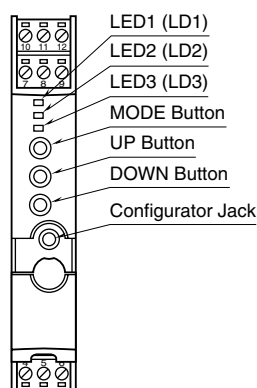

SIDE VIEW

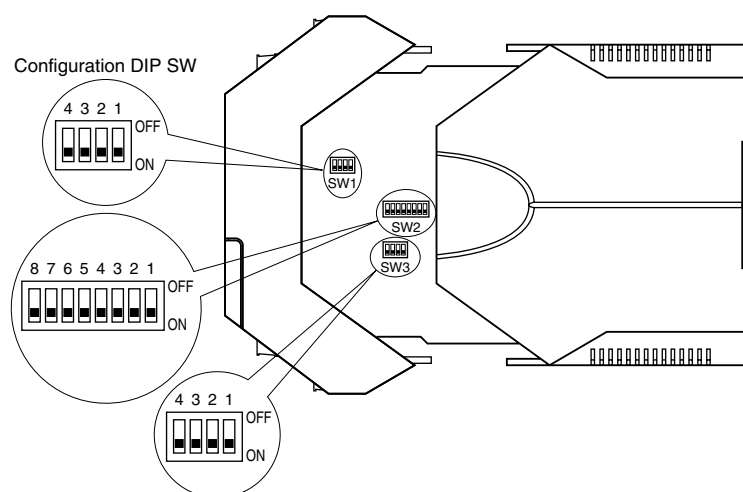

For M3LM-R4/A, the DIP switch setting is required to select output types before setting a precise output range using the PC configurator software.

CONFIGURATION MODE & DIP SW SETTINGS

When you program the transmitter module, two configuration modes are available: Field Configuration using DIP SW / control buttons, and PC Software. (The Option B type is for the field configuration only.)

The internal DIP switches are used to configure input and output type. Once the module is configured, precise ranges are set up with the front control buttons using a simulator connected to the input terminals and a multimeter connected to the output terminals as a reference.

The calibrated input and output ranges are stored in the internal memory. The module reads the DIP-switch-calibrated configuration only once after the power supply is turned on. Set the switches with the power supply removed.

Selectable I/O type and ranges are listed in Table 7 and 8.

DIP SW CONFIGURATION MODE

Turn the SW2-8 OFF to enable the DIP SW (Field Configuration) mode as shown in Table 1. See Table 3 to configure the input and Table 5 for the output.

PC CONFIGURATION MODE

Turn the SW2-8 ON to enable the PC Configuration mode as shown in Table 1. All programmable features can be set up on a PC regardless of other DIP SW setting except that the output type must be selected with the DIP SW1-1 through SW1-4 (See Table 6).

For detailed information on the PC configuration, refer to the M3CFG instruction manual.

CONFIGURATION MODE (SW2)

Table 1

MODE	SW2-8	
DIP SW	OFF	Configuration mode can be Confirmed with the front LED.
PC	ON	

FRONT CONTROL BUTTON LOCK (SW2)

Table 2

Table 2 setting is applicable to firmware version 2.02 or higher (marking on the product).

LOCK	SW2-1	
Unlock	OFF	PC Configuration is not disabled when the front control button function is locked.
Lock	ON	

POTENTIOMETER (SW2)

Table 3

RESISTANCE	SW2-7	SW2-6	SW2-5	SW2-4
0 – 20 k Ω	OFF	OFF	OFF	ON
0 – 1000 Ω	OFF	OFF	OFF	OFF
0 – 400 Ω	OFF	OFF	ON	OFF
0 – 200 Ω	OFF	OFF	ON	ON
0 – 90 Ω	OFF	ON	OFF	OFF

BURNOUT (SW3)

Table 4

BURNOUT	SW3-2	SW3-1
No burnout	OFF	ON
Upscale	OFF	OFF
Downscale	ON	OFF

OUTPUT TYPE (SW2 & 1)

Table 5

OUTPUT	SW2-3	SW2-2	SW1-4	SW1-3	SW1-2	SW1-1
0 – 20 mA	OFF	OFF	OFF	ON	OFF	OFF
-2.5 – +2.5 V	OFF	ON	ON	OFF	OFF	ON
-10 – +10 V	ON	OFF	ON	OFF	ON	OFF

OUTPUT TYPE / PC CONFIG (SW1)

Table 6

OUTPUT	SW1-4	SW1-3	SW1-2	SW1-1
0 – 20 mA	OFF	ON	OFF	OFF
-2.5 – +2.5 V	ON	OFF	OFF	ON
-10 – +10 V	ON	OFF	ON	OFF

INPUT TYPE & RANGE

Table 7

INPUT TYPE	MINIMUM SPAN	MAXIMUM RANGE
Potentiometer	2.5 Ω	0 – 90 Ω
	3 Ω	0 – 200 Ω
	3 Ω	0 – 400 Ω
	10 Ω	0 – 1000 Ω
	10 Ω	0 – 20 kΩ

OUTPUT TYPE & RANGE

Table 8

OUTPUT TYPE	MINIMUM SPAN	MAXIMUM RANGE	CONFORMANCE RANGE
DC Current	1 mA	0 to 20 mA	0 to 24 mA
DC Voltage, Narrow Spans	250 mV	-2.5 to +2.5 V	-3 to +3 V
DC Voltage, Wide Spans	1 V	-10 to +10 V	-11.5 to +11.5 V

CHECKING

- 1) Terminal wiring: Check that all cables are correctly connected according to the connection diagram.
- 2) DIP SW setting: Check that the switches are set to appropriate positions.
- 3) Power input voltage: Check voltage across the terminal 11 – 12 with a multimeter.
- 4) Input: Check that the input signal is within 0 – 100% of full-scale.

If the potentiometer or its extension wires are broken, the output goes over 100% (below 0% with downscale protection) due to burnout function. Confirm the status indicator LED pattern and check leadwires in such a case.

- 5) Output: Check that the load resistance meets the described specifications.

I/O RANGING & FINE ADJUSTMENTS

After the DIP SW setting is complete, set up the precise input and output range using the front control buttons. Be sure that the front control button function is enabled with the DIP switch setting.

The front LEDs' colors and blinking patterns help you to easily identify the transmitter's status and confirm the set-up actions in each step of Calibration Modes. Please read the following explanations referring to "Calibration Flow Chart".

PREPARATION (e.g. M3LM-R4/A)

- 1) Mount the DIP-SW-configured M3LM on to a DIN rail.
- 2) Connect the M3LM to a potentiometer and a multimeter and to a DC power source as shown below.
- 3) Turn the power supply on and wait for 10 minutes.

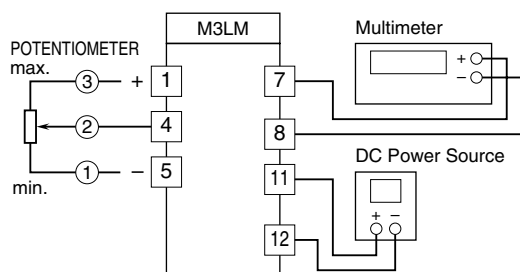

INPUT & OUTPUT RANGING

[Example] Setting the input to 0 – 1000 Ω and the output to 1 – 5 V DC

- 1) Run Mode: Confirm that the green LED is blinking (model M3LM-x/A) or the green LED turns on (model M3LM-x/B).
- 2) Input Ranging Mode: Hold down MODE button for longer than 5 seconds until the LD1 red LED is ON and the LD2 red LED is blinking.
- 3) 0% Input Ranging: Apply the desired minimum input level (e.g. 0 Ω) from the potentiometer and hold down DOWN button until the LD1 blinks for approx. 2 sec. and then turns OFF. When you release the button, the LD1 is returned to ON.
The blinking LD1 means that the value is stored in the memory. If the LED does not change, the entered level may be inappropriate: too small a span, or out of usable range (same for all steps).
- 4) 100% Input Ranging: Apply the desired maximum input level (e.g. 1000 Ω) from the potentiometer and hold down UP button until the LD1 blinks for approx. 2 sec. and then turns OFF. When you release the button, the LD1 is returned to ON.

- 5) Output Ranging Mode: Press MODE button and confirm that the LD3 red LED instead of LD2 is blinking.
- 6) 0% Output Ranging: Increase or decrease the simulated input until the meter shows the desired minimum output level (e.g. 1 V). Hold down DOWN button until the LD1 blinks for approx. 2 sec. and then turns OFF. When you release the button, the LD1 is returned to ON.
- 7) 100% Output Ranging: Increase or decrease the simulated input until the meter shows the desired maximum output level (e.g. 5 V). Hold down button until the LD1 blinks for approx. 2 sec. and then turns OFF. When you release the button, the LD1 is returned to ON.
- 8) Run Mode: When calibration is completed, press MODE button once and confirm that: the LD1 green LED is blinking in case of M3LM-x/A; and the LD1 green LED is ON in case of M3LM-x/B.

ZERO & SPAN ADJUSTMENTS

After the transmitter is installed and operational, fine zero and span tuning can be performed as explained below. Both zero and span are adjustable within $\pm 15\%$.

- 1) Run Mode: Confirm that the green LED is blinking (model M3LM-x/A) or the green LED turns on (model M3LM-x/B).
- 2) Fine Zero Adjustment Mode: Hold down MODE button for 1 or 2 seconds until the LD1 red LED is ON and the LD2 green LED is blinking.

Use UP (increase) and DOWN (decrease) buttons to adjust the output to 0%.

- 3) Fine Span Adjustment Mode: Press MODE button and confirm that the LD3 green LED instead of LD2 is blinking.
Use UP (increase) and DOWN (decrease) buttons to adjust the output to 100%.
- 4) Run Mode: When fine adjustment is completed, press MODE button once and confirm that: the LD1 green LED is blinking in case of M3LM-x/A; and the LD1 green LED is ON in case of M3LM-x/B.

Note 1: Calibration steps can be skipped when not needed by repeating pushing MODE buttons.
 Note 2: There is no stated order of setting 0% and 100% levels or no limitation of entering values for multiple times within one step of Calibration Mode. Signal level is stored each time the respective UP or DOWN button is pressed.

I/O RANGE LABEL

Blank I/O range labels are included in the product package. Write in the configured ranges and put the label on the side as shown below.

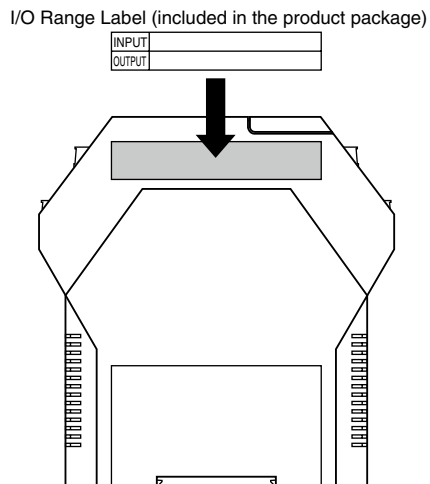



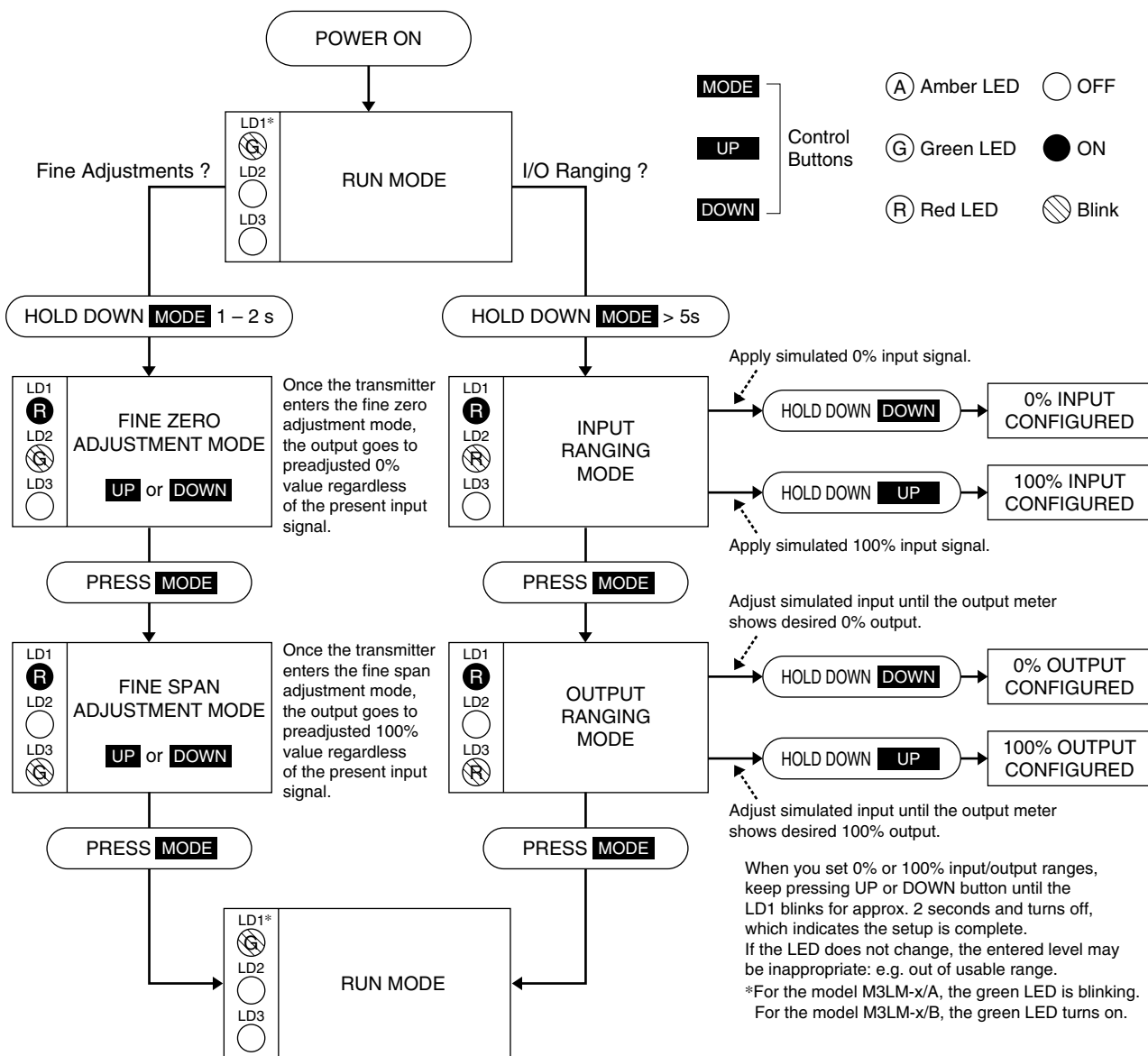



CALIBRATION FLOW CHART



























STATUS INDICATOR LED

Combinations of the three front LEDs (LD1, LD2, LD3) indicate the transmitter's operating status by different blinking patterns.

Examples are shown below.

-  Amber LED  OFF
 Green LED  ON
 Red LED  Blink

NORMAL OPERATION (RUN) MODE			
LD1  LD2  LD3 	PC Configuration RUN Mode (Option A) The transmitter is configured via PC and is in normal operating conditions.	LD1  LD2  LD3 	DIP SW Configuration RUN Mode The transmitter is configured via DIP SW and is in normal operating conditions.
ERROR MODE			
LD1  LD2  LD3 	System Error Indicates the CPU's communication error.	LD1  LD2  LD3 	DIP SW Error DIP SW configuration is inappropriate. Check the DIP SW setting referring to Tables 2 – 6.
LD1  LD2  LD3 	Burnout in PC Configuration Mode (Option A)	LD1  LD2  LD3 	Burnout in DIP SW Configuration Mode
LD1  LD2  LD3 	Output Saturated in PC Configuration Mode (Option A) The output is below -15% or above 115%.	LD1  LD2  LD3 	Output Saturated in DIP SW Configuration Mode The output is below -15% or above 115%.