

THERMOCOUPLE TRANSMITTER
(2 channel, PC programmable)MODEL **M1EXT-2****BEFORE USE**

Thank you for choosing M-System. Before use, please check contents of the package you received as outlined below.

If you have any problems or questions with the product, please contact M-System's Sales Office or representatives.

■ PACKAGE INCLUDES:

Thermocouple transmitter (body + 2 CJC sensors).....(1)

■ MODEL NO.

Confirm Model No. marking on the product to be exactly what you ordered.

■ INSTRUCTION MANUAL

This manual describes necessary points of caution when you use this product, including installation, connection and detailed operation regarding settings. For detailed explanations, please refer to the Model M1EXT-2 operating manual (EM-5985-B).

The M1EXT-2 is programmable using a PC. For detailed information on the PC configuration, refer to the M1EFCFG users manual (EM-5981).

The M1EFCFG Configurator Software and the operating manual (EM-5985-B) are downloadable at M-System's web site: <http://www.m-system.co.jp>

POINTS OF CAUTION**■ CONFORMITY WITH EU DIRECTIVES**

- This equipment is suitable for Pollution Degree 2 and Installation Category II (transient voltage 2500V). Reinforced insulation (signal input or output to power input: 300V) is maintained. Prior to installation, check that the insulation class of this unit satisfies the system requirements.
- Altitude up to 2000 meters.
- The equipment must be mounted inside a panel.
- The equipment must be installed such that appropriate clearance and creepage distances are maintained to conform to CE requirements. Failure to observe these requirements may invalidate the CE conformance.
- The actual installation environments such as panel configurations, connected devices, connected wires, may affect the protection level of this unit when it is integrated in a panel system. The user may have to review the CE requirements in regard to the whole system and employ additional protective measures to ensure the CE conformity.
- Install lightning surge protectors for those wires connected to remote locations.

■ POWER INPUT RATING & OPERATIONAL RANGE

- Locate the power input rating marked on the product and confirm its operational range as indicated below:

100 – 240V AC rating: 85 – 264V, 47 – 66 Hz,
≤ 7VA at 100V AC
≤ 10VA at 200V AC
≤ 12VA at 264V AC

24V DC rating: 24V ±10%, ≤ 4W

110V DC rating: 85 – 150V, ≤ 4W

■ GENERAL PRECAUTIONS

- Before you remove the unit from its base or mount it, turn off the power supply and input signal for safety.

■ ENVIRONMENT

- Indoor use.
- When heavy dust or metal particles are present in the air, install the unit inside proper housing with sufficient ventilation.
- Do not install the unit where it is subjected to continuous vibration. Do not subject the unit to physical impact.
- Environmental temperature must be within -5 to +55°C (23 to +131°F) with relative humidity within 10 to 85% RH in order to ensure adequate life span and operation.
- Be sure that the ventilation slits are not covered with cables, etc.

■ WIRING

- Do not install cables close to noise sources (relay drive cable, high frequency line, etc.).
- Do not bind these cables together with those in which noises are present. Do not install them in the same duct.

■ AND

- The unit is designed to function as soon as power is supplied, however, a warm up for 10 minutes is required for satisfying complete performance described in the data sheet.
- With voltage output, do not leave the output terminals shortcircuited for a long time. The unit is designed to endure it without breakdown, however, it may shorten appropriate life duration.

COMPONENT IDENTIFICATION

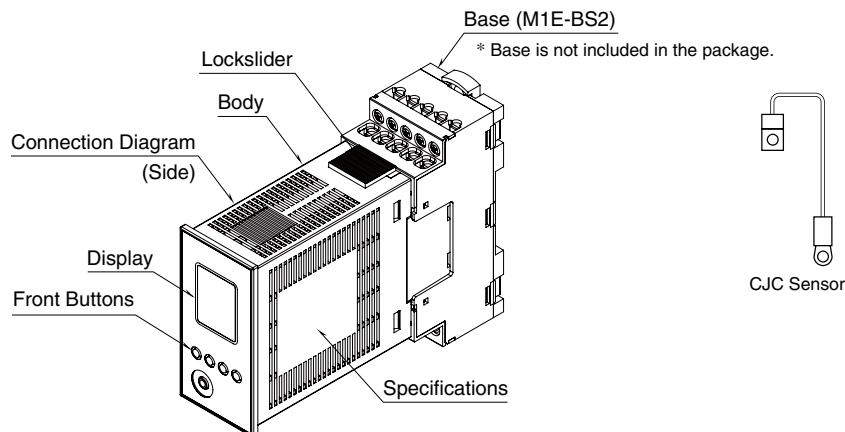

■ TERMINAL ASSIGNMENTS

1	2	3	4	5
6	7	8	9	10
11	12	13	14	15
16	17	18	19	20

No.	FUNCTION	No.	FUNCTION
1	Unused	11	Ch1 Output +
2	Unused	12	Ch1 Output -
3	Ch1 T/C +	13	Unused
4	Ch1 COM	14	Ch2 Output +
5	Ch1 CJC Sensor	15	Ch2 Output -
6	Unused	16	Unused
7	Unused	17	Unused
8	Ch2 T/C +	18	Unused
9	Ch2 COM	19	Power U (+)
10	Ch2 CJC Sensor	20	Power V (-)

INSTALLATION

Pulling out the base while pushing the lockslider on the top of the unit enables to remove the base from the unit (base is not included in the package).

■ DIN RAIL MOUNTING (SIDE)

• Mounting the unit

- Hang the upper hook at the rear side of unit on the DIN rail.
- Push the lower part of the unit in the direction of the arrow until the unit is firmly fixed to the DIN rail.

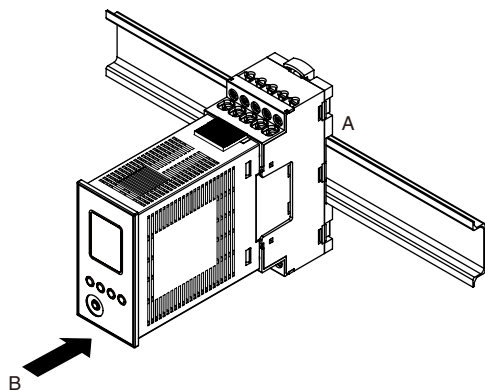

• Removing the unit

- Push down the DIN rail adaptor using a minus screwdriver.
- Pull out the lower part of the unit.
- Remove the upper part from the DIN rail.

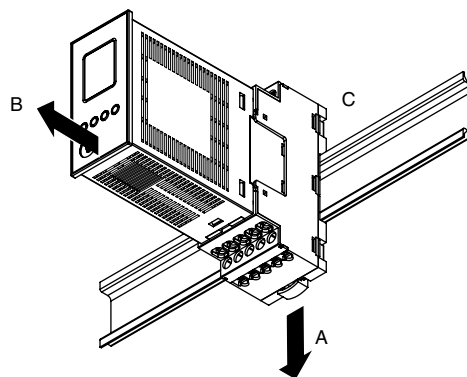

■ WALL MOUNTING

Referring to “MOUNTING REQUIREMENTS unit: mm (inch)” on page 3, pull out the upper and lower sliders of the unit and fix them with M4 screws (Torque: 1.4 N·m).

TERMINAL CONNECTIONS

Connect the unit as in the diagram below or refer to the connection diagram on the side of the unit.

EXTERNAL DIMENSIONS unit: mm (inch)

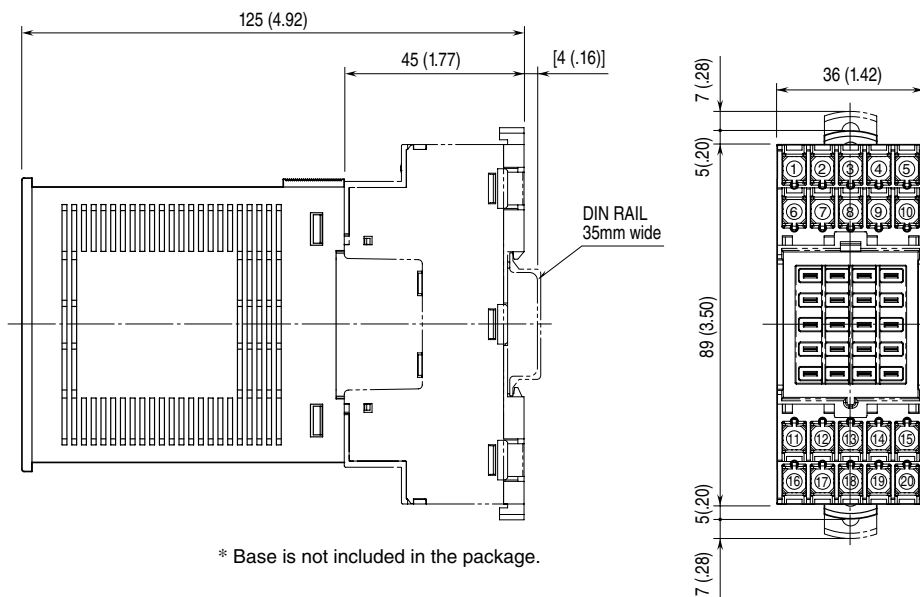

MOUNTING REQUIREMENTS unit: mm (inch)

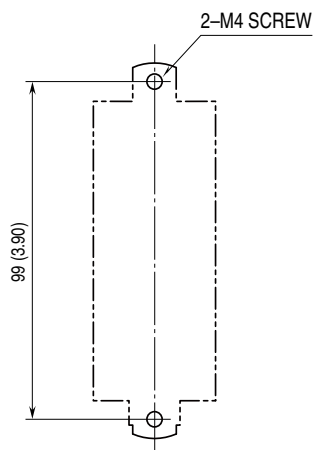

* Mounting requirements for base.

TERMINAL ASSIGNMENTS

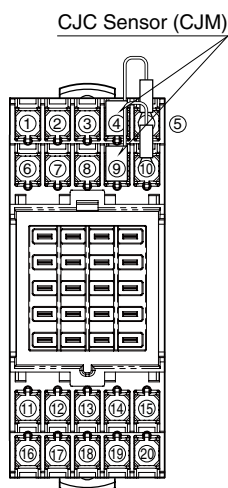

* Base is not included in the package.

CONNECTION DIAGRAM

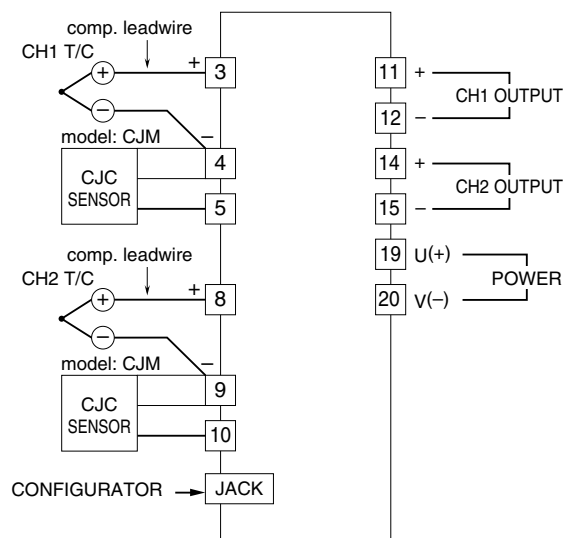

EXTERNAL VIEWS

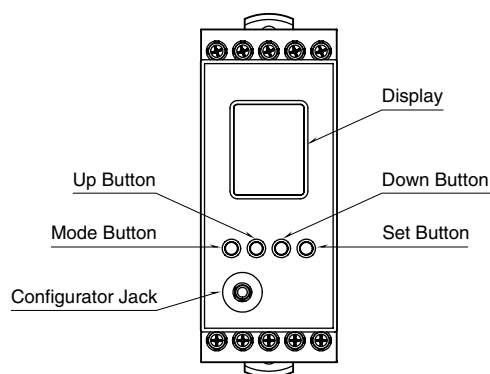

COMPONENT	FUNCTION
Display	Indicates present values, setting values and abnormal information. Two types of present values at upper and lower are displayed by setting.
Mode button	Used to shift from measuring mode to each setting mode. Destination to shift is changed by the time pressing and holding the button. Used to return from each setting mode to measuring mode (press and hold for 2 sec. or more).
Set button	Used to change setting value of setting parameter. When at setting changeable state, used to enter (save) the setting value. Used to move on through digits of setting value at setting changeable state.
Up button	Used to shift through setting parameter, and to increase or select setting value.
Down button	Used to shift through setting parameter, and to decrease or select setting value.
Configurator Jack	Used to configure with M1E configurator software (model: M1ECFG). At the same time, set the lockout setting of the unit to 'lock'.

WIRING INSTRUCTIONS FOR BASE

■ SCREW TERMINAL

Torque: 0.5 N·m

■ SOLDERLESS TERMINAL

Refer to the drawing below for recommended ring tongue terminal size. Spade tongue type is also applicable.

Recommended manufacturer: Japan Solderless Terminal MFG.Co.Ltd, Nichifu Co.,ltd (Solderless terminals with insulation sleeve do not fit)

Applicable wire size: 0.25 to 1.65 mm²

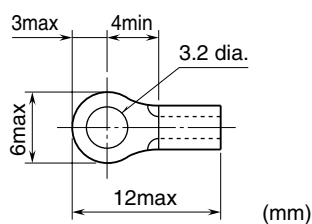

■ HOW TO ATTACH CJC SENSOR

In re-attaching once removed CJC sensor, connect it to terminals 4 and 5 or 9 and 10 as shown below.

A RTD is attached on the REAR surface of the CJC sensor. In order to measure accurate reference junction temperature, be sure to connect the sensor to terminal 4 or 9 with its upside FRONT surface.

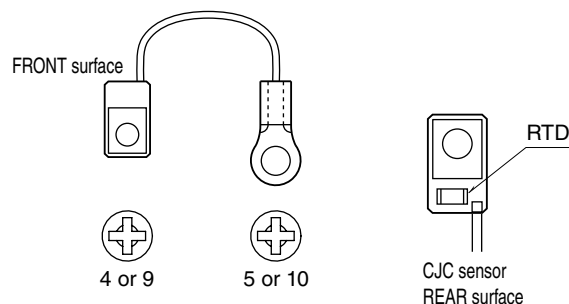

CHECKING

- 1) Terminal wiring: Check that all cables are correctly connected according to the connection diagram.
- 2) Power input voltage: Check voltage across the terminal 19 – 20 with a multimeter.
- 3) Input: Check that the input signal is within 0 – 100% of the full-scale.
If the thermocouple or its extension wires are broken, the output goes over 100% (below 0% with downscale protection) due to burnout function. Confirm the burnout error and check leadwires in such a case.
- 4) Output: Check that the load resistance meets the described specifications.

MAINTENANCE

Regular calibration procedure is explained below:

■ CALIBRATION

Warm up the unit for at least 10 minutes. Apply 0%, 25%, 50%, 75% and 100% input signal. Check that the output signal for the respective input signal remains within accuracy described in the data sheet. If the output signal is out of accuracy, when the input display value is out of accuracy, perform the input fine adjustment. When the input display value is correct but the output is out of accuracy, perform the output fine adjustment. Refer to the operating manual (EM-5985-B), when adjusting with front buttons. Refer to the M1E CFG users manual (EM-5981), when adjusting with M1E Configurator Software (model: M1E CFG). And then follow the procedure shown below.

• INPUT FINE ADJUSTMENT

- 1) Set the simulated input signal to 0 %, and adjust the input display to 0 % by [80]/[180] Input Zero fine adjust.
- 2) Set the simulated input signal to 100 %, and adjust the input display to 100 % by [81]/[181] Input Span fine adjust.
- 3) Again set the simulated input to 0 %, confirm the input display.
- 4) If input display is shifted, repeat the procedure from 1) to 3).

• OUTPUT FINE ADJUSTMENT

- 1) Set the simulated input to 0 %, and adjust the output signal to 0 % by [82]/[182] Output Zero fine adjust.
- 2) Set the simulated input to 100 %, and adjust the output signal to 100 % by [83]/[183] Output Span fine adjust.
- 3) Again set the simulated input to 0 %, confirm the output signal.
- 4) If output signal is shifted, repeat the procedure from 1) to 3).

LIGHTNING SURGE PROTECTION

M-System offers a series of lightning surge protector for protection against induced lightning surges. Please contact M-System to choose appropriate models.